

PRODUCT NUMBER
SEE TABLE

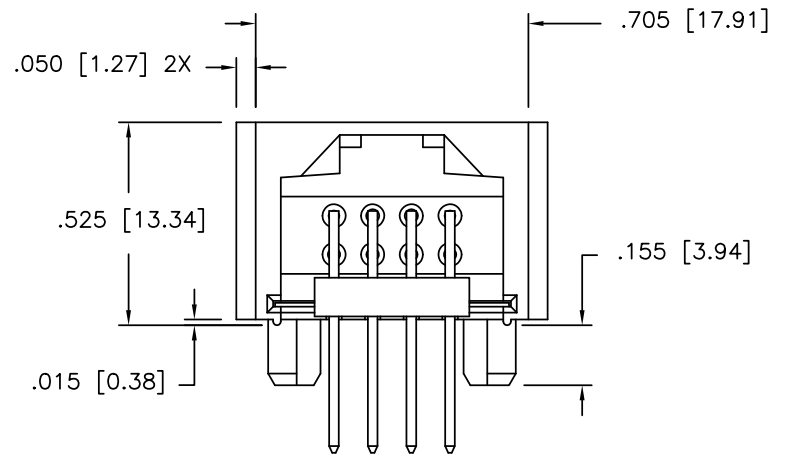
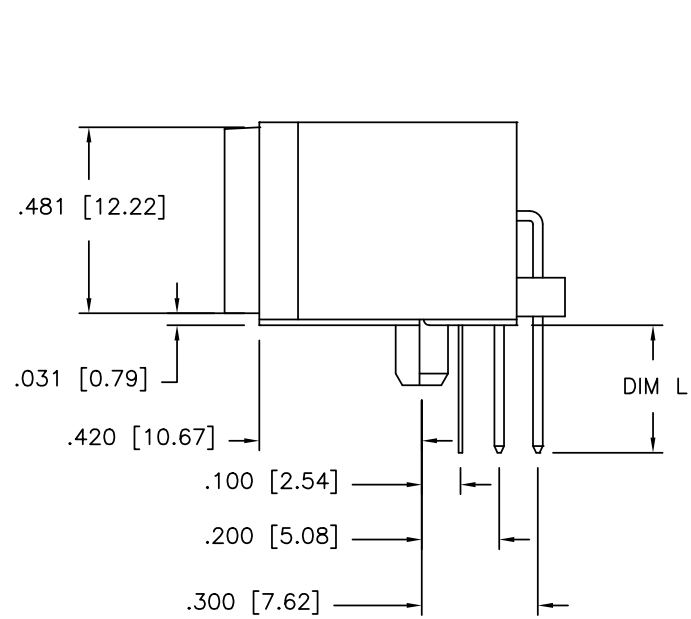
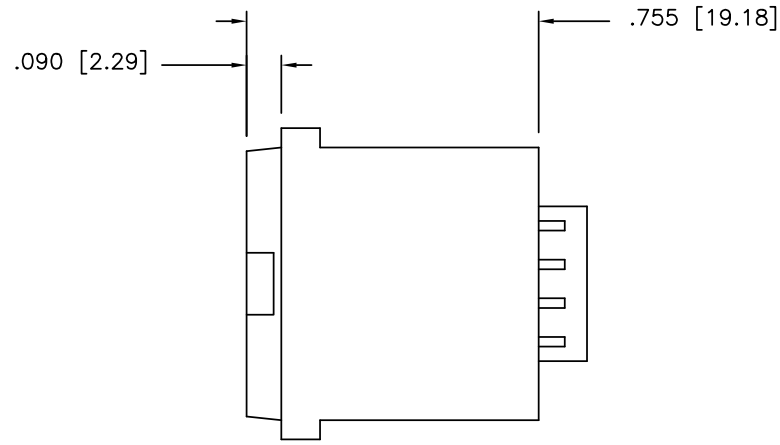

mat'l. code		surface ISO 1302 ✓		tolerance ISO 406 ISO 1101		projection ASME Y14.5		product family LATCH-N-LOK	
ltr ecn nodr date		tolerances unless otherwise specified		title		INCH/MM		2X4 LNL LOW PROFILE HEADER ASSEMBLY	
M	M07-0521	AGS	12/10/07	angles	XXX±.01/0.XX±0.3	scale 2:1		dwg no 69958 sheet 1 of 2 size A3	
N	ELX-N-004176	KW	06/22/11	linea	XXX±.005/0.XX±0.13	FCI		type Product Customer Drawing	
P	ELX-N-008473	ZK	11/28/11	0°±2'	XXX±.0020/0.XXX±0.051				
J	M05-0052	MHT	3/16/05	engr	D. HORCHLER	12/22/89			
K	M06-0285	AGS	7/28/06	chr	D. HORCHLER	12/22/89			
L	M06-0365	AGS	9/20/06	app	D. HORCHLER	12/22/89			
sheet	revision	P	P						
index	sheet	1	2						

69958-XXXXLF

LEAD FREE OPTION (6)(8)

HIGH TEMPERATURE (7)

COLOR (4)	
1	70343-LT GRAY OBS
2	80166 OFF WHITE
3	70634-DK GRAY OBS
4	701 BLACK
5	70511-SLATE GRAY OBS
7	70455 SILVER GRAY
8	80189 PEARL WHITE OBS
9	70419 PEBBLE GRAY

PLATING (3)	
0	30u" MIN OVER 50u"MIN Ni
3	30u" MIN OVER 50u"MIN Ni
5	50u" MIN OVER 50u"MIN Ni

PIN LENGTH	
DIM L	
0	.200/5.08
1	.130/3.30

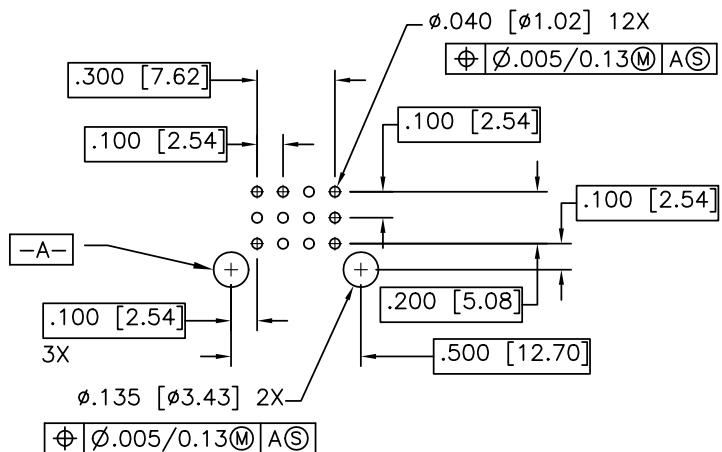

RECOMMENDED PCB LAYOUT

NOTES:

- HEADER SHROUD
MAT'L: HIGH TEMPERATURE THERMOPLASTIC, UL-94V-0 RATED
- GROUND CONTACT
MAT'L: COPPER ALLOY
PLATING: 100-160u"/2.54-4.06u TIN.
- SIGNAL CONTACT
MAT'L: COPPER ALLOY
PLATING OPTIONALLY: PERFORMANCE PLATING WILL BE EITHER GOLD OR GXT ON CONTACT AREA OR TAIL, OPTIONALLY (78---295u") TIN ON TAIL.
- NUMBERS SHOWN ARE FOR G.E. LEXAN AND ARE FOR REFERENCE ONLY.
- THIS ASSEMBLY UL APPROVED PER FILE E66906 VOL. 1, SEC. 84 AND CSA APPROVED PER MASTER FILE LR46923
- ADD LF SUFFIX AT THE END OF PART NUMBER FOR LEAD FREE OPTION.
- FOR 69958-XXXXLF THE HOUSING WILL WITHSTAND EXPOSURE TO 260°C PEAK TEMPERATURE FOR 69958-XXXXMLF CAN WITHSTAND EXPOSURE TO 270°C PEAK TEMPERATURE FOR 15 SECONDS IN A WAVE SOLDER APPLICATION WITH A 1.5mm MINIMUM THICK CIRCUIT BOARD. SEE APPLICATION NOTES/PROCEDURES IF THEY ARE AVAILABLE.
- THIS PRODUCT MEETS EUROPEAN UNION DIRECTIVES AND OTHER COUNTRY REGULATION AS DESCRIBED IN GS-22-008.
- PRODUCT SPEC: GS-12-003

mat'l. code		surface ISO 1302 ✓	tolerance ISO 406 ISO 1101	projection INCH/MM	product family LATCH-N-LOK
ltr	ecn	nldr	date	title	
P				2X4 LNL LOW PROFILE HEADER ASSEMBLY	
tolerances unless otherwise specified				scale 1:1	dwg no
angles	line	.XX±.01/.3 XXX±.005/.13 XXXX±.0020/.051		sheet 2 of 2	size
0°±2'				69958	A3
dr	M. CLOUSER	12/22/89		type Product Customer Drawing	
engr	D. HORCHLER	12/22/89			
chr	D. HORCHLER	12/22/89			
app	D. HORCHLER	12/22/89			
sheet index	revision sheet				



Copyright FCI