

FEATURES

Tracking R/D Converter
 High Accuracy Velocity Output
 High Max Tracking Rate 1040 RPS (10 Bits)
 44-Lead PLCC Package
 10-, 12-, 14-, or 16-Bit Resolution Set by User
 Ratiometric Conversion
 Stabilized Velocity Reference
 Dynamic Performance Set by User
 Industrial Temperature Range

APPLICATIONS

DC and AC Servo Motor Control
 Process Control
 Numerical Control of Machine Tools
 Robotics
 Axis Control

FUNCTIONAL BLOCK DIAGRAM

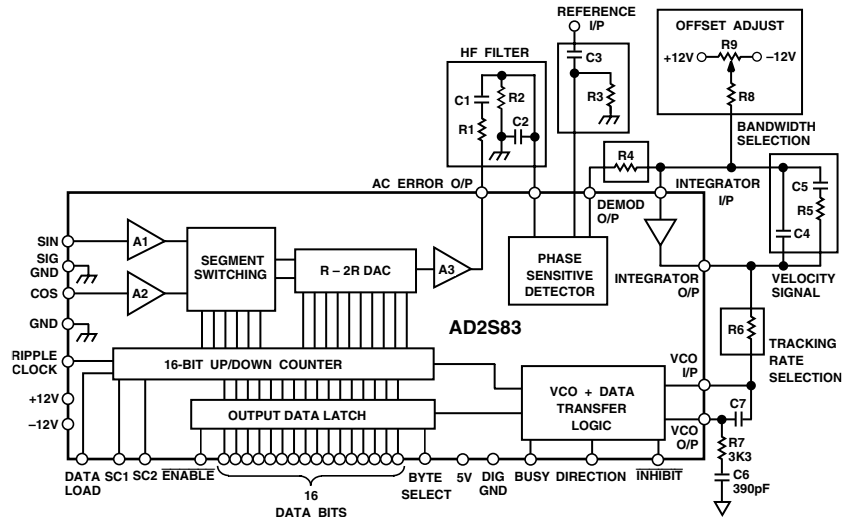

GENERAL DESCRIPTION

The AD2S83 is a monolithic 10-, 12-, 14-, or 16-bit tracking resolver-to-digital converter.

The converter allows users to *select their own resolution and dynamic performance with external components*. The converter allows users to select the resolution to be 10, 12, 14, or 16 bits and to track resolver signals rotating at up to 1040 revs per second (62,400 rpm) when set to 10-bit resolution.

The AD2S83 converts resolver format input signals into a parallel natural binary digital word using a ratiometric tracking conversion method. This ensures high noise immunity and tolerance of long leads allowing the converter to be located remote from the resolver.

The position output from the converter is presented via 3-state output pins which can be configured for operations with 8- or 16-bit bus. $\overline{\text{BYTE SELECT}}$, $\overline{\text{ENABLE}}$ and $\overline{\text{INHIBIT}}$ pins ensure easy data transfer to 8- and 16-bit data bus, and outputs are provided to allow for cycle or pitch counting in external counters.

A precise analog signal proportional to velocity is also available and will replace a tachogenerator.

The AD2S83 operates over reference frequencies in the range 0 Hz to 20,000 Hz.

PRODUCT HIGHLIGHTS

High Accuracy Velocity Output. A precision analog velocity signal with a typical linearity of $\pm 0.1\%$ and reversion error less than $\pm 0.3\%$ is generated by the AD2S83. The provision of this signal removes the need for mechanical tachogenerators used in servo systems to provide loop stabilization and speed control.

Resolution Set by User. Two control pins are used to select the resolution of the AD2S83 to be 10, 12, 14 or 16 bits allowing optimum resolution for each application.

Ratiometric Tracking Conversion. This technique provides continuous output position data without conversion delay. It also provides noise immunity and tolerance of harmonic distortion on the reference and input signals.

Dynamic Performance Set by the User. By selecting external resistor and capacitor values the user can determine bandwidth, maximum tracking rate and velocity scaling of the converter to match the system requirements. The component values are easy to select using the free component selection software design aid.

MODELS AVAILABLE

Information on the models available is given in the Ordering Guide.

REV. E

Information furnished by Analog Devices is believed to be accurate and reliable. However, no responsibility is assumed by Analog Devices for its use, nor for any infringements of patents or other rights of third parties which may result from its use. No license is granted by implication or otherwise under any patent or patent rights of Analog Devices.

AD2S83—SPECIFICATIONS ($\pm V_S = \pm 12\text{ V dc} \pm 5\%$; $V_L = 5\text{ V dc} \pm 10\%$; $T_A = -40^\circ\text{C to } +85^\circ\text{C}$)

Parameter	Conditions	Min	Typ	Max	Unit
SIGNAL INPUTS (SIN, COS) Frequency ¹ Voltage Level Input Bias Current Input Impedance		0 1.8 1.0	2.0 60	20,000 2.2 150	Hz V rms nA M Ω
REFERENCE INPUT (REF) Frequency Voltage Level Input Bias Current Input Impedance		0 1.0 1.0	60	20,000 8.0 150	Hz V pk nA M Ω
PERFORMANCE Repeatability Allowable Phase Shift Max Tracking Rate Bandwidth	(Signals to Reference) 10 Bits 12 Bits 14 Bits 16 Bits User Selectable	-10 1040 260 65 16.25		1 +10	LSB Degree rps rps rps rps
ACCURACY Angular Accuracy Monotonicity Missing Codes (16-Bit Resolution)	A, I Guaranteed Monotonic A, I			$\pm 8 + 1\text{ LSB}$ 4	arc min Codes
VELOCITY SIGNAL LINEARITY ^{2, 3, 4} AD2S83AP 0 kHz–500 kHz 0.5 MHz–1 MHz AD2S83IP 0 kHz–500 kHz 0.5 MHz–1 MHz Reversion Error AD2S83AP AD2S83IP DC Zero Offset ⁵ Gain Scaling Accuracy Output Voltage Dynamic Ripple	-40°C to +85°C -40°C to +85°C -40°C to +85°C -40°C to +85°C -40°C to +85°C -40°C to +85°C		± 0.15 ± 0.25 ± 0.25 ± 0.25 ± 1.0 ± 1.5	± 0.25 ± 1.0 ± 0.5 ± 1.5 ± 3 ± 3 1.0	% FSR % FSR % FSR % FSR % O/P % O/P mV % FSR V % rms O/P
INPUT/OUTPUT PROTECTION Analog Inputs Analog Outputs	Overvoltage Protection Short Circuit O/P Protection	± 5.6	± 8 ± 8	± 10.4	V mA
DIGITAL POSITION Resolution Output Format Load	10, 12, 14, and 16 Bidirectional Natural Binary			3	Bits LSTTL
INHIBIT ⁶ Sense Time to Stable Data	Logic LO to $\overline{\text{INHIBIT}}$	240	390	490	ns
ENABLE ⁶ $\overline{\text{ENABLE}}$ /Disable Time	Logic LO Enables Position Output Logic HI Outputs in High Impedance State	35		110	ns
BYTE SELECT ⁶ Sense Logic HI Logic LO Time to Data Available	MS Byte DB1–DB8 LS Byte DB1–DB8	60		140	ns
SHORT CYCLE INPUTS SC1 SC2 0 0 0 1 1 0 1 1	Internally Pulled High via 100 k Ω to +V _S 10-Bit Resolution 12-Bit Resolution 14-Bit Resolution 16-Bit Resolution				

Parameter	Conditions	Min	Typ	Max	Unit
<u>COMPLEMENT</u>	Internally Pulled High via 100 k Ω to +V _S . Logic LO to Activate; No Connect for Normal Operation				
<u>DATA LOAD</u> Sense	Internally Pulled High via 100 k Ω to +V _S . Logic LO Allows Data to be Loaded into the Counters from the Data Lines		150	300	ns
BUSY ^{6,7} Sense Width Load	Logic HI When Position O/P Changing Use Additional Pull-Up (See Figure 2)	150		350 1	ns LSTTL
<u>DIRECTION</u> ⁶ Sense Max Load	Logic HI Counting Up Logic LO Counting Down			3	LSTTL
<u>RIPPLE CLOCK</u> ⁶ Sense Width Reset Load	Logic HI All 1s to All 0s All 0s to All 1s Dependent on Input Velocity Before Next Busy	300		3	ns LSTTL
DIGITAL INPUTS Input High Voltage, V _{IH} Input Low Voltage, V _{IL}	<u>INHIBIT</u> , <u>ENABLE</u> DB1-DB16, Byte Select $\pm V_S = \pm 11.4$ V, V _L = 5.0 V <u>INHIBIT</u> , <u>ENABLE</u> DB1-DB16, Byte Select $\pm V_S = \pm 12.6$ V, V _L = 5.0 V	2.0		0.8	V V
DIGITAL INPUTS Input High Current, I _{IH} Input Low Current, I _{IL}	<u>INHIBIT</u> , <u>ENABLE</u> DB1-DB16 $\pm V_S = \pm 12.6$ V, V _L = 5.5 V <u>INHIBIT</u> , <u>ENABLE</u> DB1-DB16, Byte Select $\pm V_S = \pm 12.6$ V, V _L = 5.5 V			± 100 ± 100	μ A μ A
DIGITAL INPUTS Low Voltage, V _{IL} Low Current, I _{IL}	<u>ENABLE</u> = HI SC1, SC2, DATA LOAD $\pm V_S = \pm 12.0$ V, V _L = 5.0 V <u>ENABLE</u> = HI SC1, SC2, DATA LOAD $\pm V_S = \pm 12.0$ V, V _L = 5.0 V			1.0 -400	V μ A
DIGITAL OUTPUTS High Voltage, V _{OH} Low Voltage, V _{OL}	DB1-DB16 RIPPLE CLK, DIR $\pm V_S = \pm 12.0$ V, V _L = 4.5 V I _{OH} = 100 μ A DB1-DB16 RIPPLE CLK, DIR $\pm V_S = \pm 12.0$ V, V _L = 5.5 V I _{OL} = 1.2 mA	2.4		0.4	V V

NOTES

¹Angular accuracy is not guaranteed <50 Hz reference frequency.

²Linearity derates from 500 kHz–1000 kHz @ 0.0017%/kHz.

³Refer to Definition of Linearity, “The AD2S83 as a Silicon Tachogenerator.”

⁴Worst case reversion error at temperature extremes.

⁵Velocity output offset dependent on value for R6.

⁶Refer to timing diagram.

⁷Busy pulse guaranteed up to a VCO rate of 900 kHz.

All min and max specifications are guaranteed. Specifications in **boldface** are tested on all production units at final electrical test. Specifications subject to change without notice.

AD2S83—SPECIFICATIONS ($\pm V_S = \pm 12$ V dc $\pm 5\%$; $V_L = 5$ V dc $\pm 10\%$; $T_A = -40^\circ\text{C}$ to $+85^\circ\text{C}$)

Parameter	Conditions	Min	Typ	Max	Unit
THREE-STATE LEAKAGE Current I_L	DB1–DB16 Only $\pm V_S = \pm 12.0$ V, $V_L = 5.5$ V $V_{OL} = 0$ V			± 20	μA
	$\pm V_S = \pm 12.0$ V, $V_L = 5.5$ V $V_{OH} = 5.0$ V			± 20	μA
RATIO MULTIPLIER AC Error Output Scaling	10 Bit 12 Bit 14 Bit 16 Bit		177.6 44.4 11.1 2.775		mV/Bit mV/Bit mV/Bit mV/Bit
PHASE SENSITIVE DETECTOR Output Offset Voltage Gain				12	mV
In Phase	w.r.t. REF	-0.882	-0.9	-0.918	V rms/V dc
In Quadrature	w.r.t. REF			± 0.02	V rms/V dc
Input Bias Current			60	150	nA
Input Impedance		1.0			$M\Omega$
Input Voltage				± 8	V
INTEGRATOR Open-Loop Gain	At 10 kHz	57	60	63	dB
Dead Zone Current (Hysteresis)		90	100	110	nA/LSB
Input Offset Voltage			1	5	mV
Input Bias Current			60	150	nA
Output Voltage Range		± 8			V
VCO Maximum Rate		1.1			MHz
VCO Rate	+ve DIR	8.25	8.50	8.75	kHz/ μA
	-ve DIR	8.25	8.50	8.75	kHz/ μA
VCO Power Supply Sensitivity Rate	$+V_S$			+0.5	%/V
	$-V_S$			-0.5	%/V
Input Offset Voltage			3		mV
Input Bias Current			12	50	nA
Input Bias Current Tempco			+0.22		nA/ $^\circ\text{C}$
Linearity of Absolute Rate					
AD2S83AP					
0 kHz–500 kHz			± 0.15	± 0.25	% FSR
0.5 MHz–1 MHz			± 0.25	± 1.0	% FSR
AD2S83IP					
0 kHz–500 kHz			± 0.25	± 0.5	% FSR
0.5 MHz–1 MHz			± 0.25	± 1.0	% FSR
Reversion Error					
AD2S83AP			± 0.5	± 1.0	% Output
AD2S83IP			± 1.0	± 1.5	% Output
POWER SUPPLIES Voltage Levels					
$+V_S$		+11.4		+12.6	V
$-V_S$		-11.4		-12.6	V
$+V_L$		+4.5	+5	$+V_S$	V
Current					
$\pm I_S$	$\pm V_S @ \pm 12$ V		± 12	± 23	mA
$\pm I_S$	$\pm V_S @ \pm 12.6$ V		± 19	± 30	mA
$\pm I_L$	$+V_L @ \pm 5.0$ V		± 0.5	± 1.5	mA

All min and max specifications are guaranteed. Specifications in **boldface** are tested on all production units at final electrical test.
Specifications subject to change without notice.

ORDERING GUIDE

Model	Temperature Range	Accuracy	Package Description	Package Option
AD2S83AP	-40°C to +85°C	8 arc min	Plastic Leaded Chip Carrier	P-44A
AD2S83IP	-40°C to +85°C	8 arc min	Plastic Leaded Chip Carrier	P-44A

ABSOLUTE MAXIMUM RATINGS¹ (with respect to GND)

+V _S ²	+13 V dc
-V _S ²	-13 V dc
+V _L	+V _S
Reference	+13 V to -V _S
SIN	+13 V to -V _S
COS	+13 V to -V _S
Any Logical Input	-0.4 V dc to +V _L dc
Demodulator Input	+13 V to -V _S
Integrator Input	+13 V to -V _S
VCO Input	+13 V to -V _S
Power Dissipation	800 mW
Operating Temperature	
Industrial (AP, IP)	-40°C to +85°C
Storage Temperature	-65°C to +150°C
Lead Temperature (Soldering, 10 sec)	300°C

CAUTION

¹Absolute Maximum Ratings are those values beyond which damage to the device may occur.

²Correct polarity voltages must be maintained on the +V_S and -V_S pins.

RECOMMENDED OPERATING CONDITIONS

Power Supply Voltage (+V _S , -V _S)	±12 V dc ± 5%
Power Supply Voltage V _L	+5 V dc ± 10%
Analog Input Voltage (SIN and COS)	2 V rms ± 10%
Analog Input Voltage (REF)	1 V to 8 V peak
Signal and Reference Harmonic Distortion	10% (max)
Phase Shift Between Signal and Reference ...	±10 Degrees (max)
Ambient Operating Temperature Range	
Industrial (AP, IP)	-40°C to +85°C

PIN CONFIGURATION

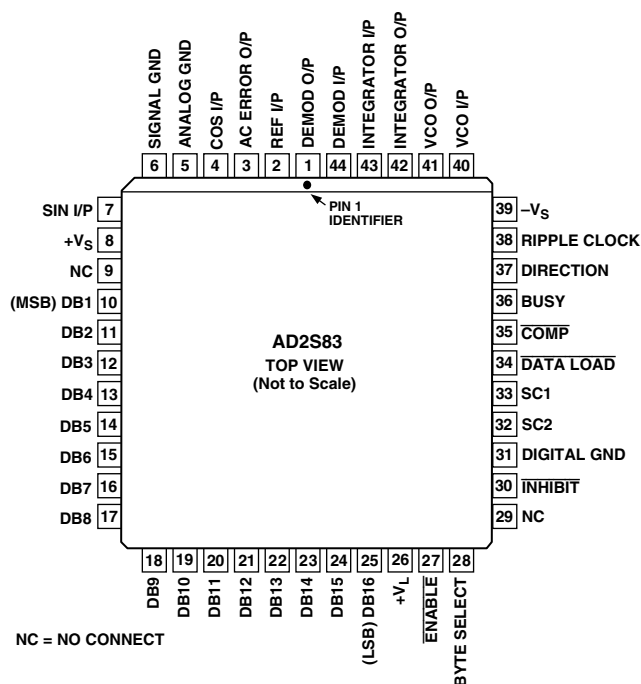

PIN FUNCTION DESCRIPTIONS

Pin Nos.	Mnemonic	Description
1	DEM O/P	Demodulator Output
2	REFERENCE I/P	Reference Signal Input
3	AC ERROR O/P	Ratio Multiplier Output
4	COS	Cosine Input
5	ANALOG GND	Power Ground
6	SIGNAL GND	Resolver Signal Ground
7	SIN	Sine Input
8	+V _S	Positive Power Supply
10-25	DB1-DB16	Parallel Output Data
26	+V _L	Logic Power Supply
27	ENABLE	Logic HI—Output Data Pins in High Impedance State Logic LO—Presents Active Data to the Output Pins
28	BYTE SELECT	Logic HI—Most Significant Byte to DB1-DB8 Logic LO—Least Significant Byte to DB1-DB8
30	INHIBIT	Logic LO Inhibits Data Transfer to Output Latches
31	DIGITAL GND	Digital Ground
32, 33	SC2-SC1	Select Converter Resolution
34	DATA LOAD	Logic LO DB1-DB16 Inputs Logic HI DB1-DB16 Outputs
35	COMPLEMENT	Active Logic LO
36	BUSY	Converter Busy, Data not Valid While Busy HI
37	DIRECTION	Logic State Defines Direction of Input Signal Rotation
38	RIPPLE CLOCK	Positive Pulse When Converter Output Changes from 1s to All 0s or Vice Versa
39	-V _S	Negative Power Supply
40	VCO I/P	VCO Input
41	VCO O/P	VCO Output
42	INTEGRATOR O/P	Integrator Output
43	INTEGRATOR I/P	Integrator Input
44	DEM O/P	Demodulator Input

CAUTION

ESD (electrostatic discharge) sensitive device. Electrostatic charges as high as 4000 V readily accumulate on the human body and test equipment and can discharge without detection. Although the AD2S83 feature proprietary ESD protection circuitry, permanent damage may occur on devices subjected to high-energy electrostatic discharges. Therefore, proper ESD precautions are recommended to avoid performance degradation or loss of functionality.



AD2S83

Bit Weight Table

Binary Bits (N)	Resolution (N ^N)	Degrees /Bit	Minutes /Bit	Seconds /Bit
0	1	360.0	21600.0	1296000.0
1	2	180.0	10800.0	648000.0
2	4	90.0	5400.0	324000.0
3	8	45.0	2700.0	162000.0
4	16	22.5	1350.0	81000.0
5	32	11.25	675.0	40500.0
6	64	5.625	337.5	20250.0
7	128	2.8125	168.75	10125.0
8	256	1.40625	84.375	5062.5
9	512	0.703125	42.1875	2531.25
10	1024	0.3515625	21.09375	1265.625
11	2048	0.1757813	10.546875	632.8125
12	4096	0.0878906	5.273438	316.40625
13	8192	0.0439453	2.636719	158.20313
14	16384	0.0219727	1.318359	79.10156
15	32768	0.0109836	0.659180	39.55078
16	65536	0.0054932	0.329590	19.77539
17	131072	0.0027466	0.164795	9.88770
18	262144	0.0013733	0.082397	4.94385

CONNECTING THE CONVERTER

The power supply voltages connected to +V_S and -V_S pins should be +12 V dc and -12 V dc and must not be reversed. The voltage applied to V_L can be +5 V dc to +V_S.

It is recommended that the decoupling capacitors are connected in parallel between the power lines +V_S, -V_S and ANALOG GROUND adjacent to the converter. Recommended values are 100 nF (ceramic) and 10 μF (tantalum). Also capacitors of 100 nF and 10 μF should be connected between +V_L and DIGITAL GROUND adjacent to the converter.

When more than one converter is used on a card, separate decoupling capacitors should be used for each converter.

The resolver connections should be made to the SIN and COS inputs, REFERENCE INPUT and SIGNAL GROUND as shown in Figure 11 and described in the Connecting the Resolver section.

The two signal ground wires from the resolver should be joined at the SIGNAL GROUND pin of the converter to minimize the coupling between the sine and cosine signals. For this reason it is also recommended that the resolver is connected using individually screened twisted pair cables with the sine, cosine and reference signals twisted separately.

SIGNAL GROUND and ANALOG GROUND are connected internally. ANALOG GROUND and DIGITAL GROUND must be connected externally and as close to the converter as possible.

The external components required should be connected as shown in Figure 1.

CONVERTER RESOLUTION

Two major areas of the AD2S83 specification can be selected by the user to optimize the total system performance. The resolution of the digital output is set by the logic state of the inputs SC1 and SC2 to be 10, 12, 14 or 16 bits; and the dynamic characteristics of bandwidth and tracking rate are selected by the choice of external components.

The choice of the resolution will affect the values of R4 and R6 which scale the inputs to the integrator and the VCO respectively (see Component Selection section). If the resolution is changed, then new values of R4 and R6 must be switched into the circuit.

Note: When changing resolution under dynamic conditions, do it when the BUSY is low, i.e., when data is not changing.

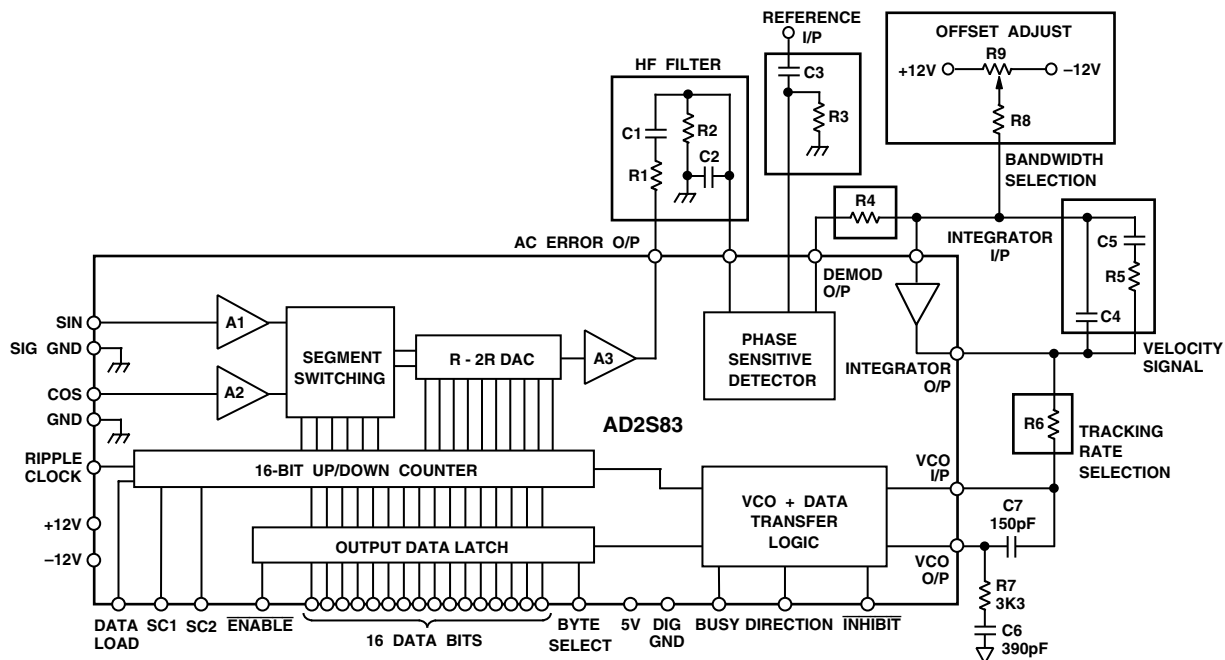

Figure 1. Connection Diagram

CONVERTER OPERATION

When connected in a circuit such as shown in Figure 10, the AD2S83 operates as a tracking resolver-to-digital converter. The output will automatically follow the input for speeds up to the selected maximum tracking rate. No convert command is necessary as the conversion is automatically initiated by each LSB increment, or decrement, of the input. Each LSB change of the converter initiates a BUSY pulse.

The AD2S83 is remarkably tolerant of input amplitude and frequency variation because the conversion depends only on the ratio of the input signals. Consequently there is no need for accurate, stable oscillator to produce the reference signal. The inclusion of the phase sensitive detector in the conversion loop ensures high immunity to signals that are not phase or frequency coherent or are in quadrature with the reference signal.

SIGNAL CONDITIONING

The amplitude of the SINE and COSINE signal inputs should be maintained within 10% of the nominal values if full performance is required from the velocity signal.

The digital position output is relatively insensitive to amplitude variation. Increasing the input signal levels by more than 10% will result in a loss in accuracy due to internal overload. Reducing levels will result in a steady decline in accuracy. With the signal levels at 50% of the correct value, the angular error will increase to an amount equivalent to 1.3 LSB. At this level the repeatability will also degrade to 2 LSB and the dynamic response will also change, since the dynamic characteristics are proportional to the signal level.

The AD2S83 will not be damaged if the signal inputs are applied to the converter without the power supplies and/or the reference.

REFERENCE INPUT

The amplitude of the reference signal applied to the converter's input is not critical, but care should be taken to ensure it is kept within the recommended operating limits.

The AD2S83 will not be damaged if the reference is supplied to the converter without the power supplies and/or the signal inputs.

HARMONIC DISTORTION

The amount of harmonic distortion allowable on the signal and reference lines is 10%.

Square waveforms can be used but the input levels should be adjusted so that the average value is 1.9 V rms. (For example, a square wave should be 1.9 V peak.) Triangular and sawtooth waveforms should have a amplitude of 2 V rms.

Note: The figure specified of 10% harmonic distortion is for calibration convenience only.

POSITION OUTPUT

The resolver shaft position is represented at the converter output by a natural binary parallel digital word. As the digital position output of the converter passes through the major carries, i.e., all "1s" to all "0s" or the inverse, a RIPPLE CLOCK (RC) logic output is initiated indicating that a revolution or a pitch of the input has been completed.

The direction of input rotation is indicated by the DIRECTION (DIR) logic output. This direction data is always valid in advance of a RIPPLE CLOCK pulse and, as it is internally latched, only changing state (1 LSB min change in input) with a corresponding change in direction.

Both the RIPPLE CLOCK pulse and the DIRECTION data are unaffected by the application of the $\overline{\text{INHIBIT}}$. The static positional accuracy quoted is the worst case error that can occur over the full operating temperature excluding the effects of offset signals at the INTEGRATOR INPUT (which can be trimmed out—see Figure 1), and with the following conditions: input signal amplitudes are within 10% of the nominal; phase shift between signal and reference is less than 10 degrees.

These operating conditions are selected primarily to establish a repeatable acceptance test procedure which can be traced to national standards. In practice, the AD2S83 can be used well outside these operating conditions providing the above points are observed.

VELOCITY SIGNAL

The tracking converter technique generates an internal signal at the output of the integrator (INTEGRATOR OUTPUT) that is proportional to the rate of change of the input angle. This is a dc analog output referred to as the VELOCITY signal.

It is recommended that the velocity output be buffered.

The sense is positive for an increasing angular input and negative for decreasing angular input. The full-scale velocity output is ± 8 V dc. The output velocity scaling and tracking rate are a function of the resolution of the converter; this is summarized below.

Res	Max Tracking Rate (rps)	Nominal Scaling (rps/V dc)
10	1040	130
12	260	32.5
14	65	8.125
16	16.25	2.03

(Velocity O/P = ± 8 V dc nominal)

The output velocity can be suitably scaled and used to replace a conventional DC tachogenerator. For more detailed information see the AD2S83 as a Silicon Tachogenerator section.

DC ERROR SIGNAL

The signal at the output of the phase sensitive detector (DEMODULATOR OUTPUT) is the signal to be nulled by the tracking loop and is, therefore, proportional to the error between the input angle and the output digital angle. As the converter is a Type 2 servo loop, the demodulator output signal will increase if the output fails to track the input for any reason. This is an indication that the input has exceeded the maximum tracking rate of the converter or, due to some internal or external malfunction, the converter is unable to reach a null. By connecting two external comparators, this voltage can be used as a "built-in-test."

AD2S83

COMPONENT SELECTION

The following instructions describe how to select the external components for the converter in order to achieve the required bandwidth and tracking rate. In all cases the nearest “preferred value” component should be used, and a 5% tolerance will not degrade the overall performance of the converter. Care should be taken that the resistors and capacitors will function over the required operating temperature range. The components should be connected as shown in Figure 1.

Free PC compatible software is available to help users select the optimum component values for the AD2S83, and display the transfer gain, phase and small step response.

For more detailed information and explanation, see the Circuit Functions and Dynamic Performance section.

1. HF Filter (R1, R2, C1, C2)

The function of the HF filter is to remove any dc offset and to reduce the amount of noise present on the signal inputs to the AD2S83, reaching the Phase Sensitive Detector and affecting the outputs. R1 and C2 may be omitted—in which case R2 = R3 and C1 = C3, calculated below—but their use is particularly recommended if noise from switch mode power supplies and brushless motor drive is present.

Values should be chosen so that

$$15 \text{ k}\Omega \leq R1 = R2 \leq 56 \text{ k}\Omega$$

$$C1 = C2 = \frac{1}{2\pi R1 f_{REF}}$$

and f_{REF} = Reference Frequency (Hz)

This filter gives an attenuation of three times at the input to the phase sensitive detector.

2. Gain Scaling Resistor (R4) (See Phase Sensitive Demodulator section.)

If R1, C2 are used:

$$R4 = \frac{E_{DC}}{100 \times 10^{-9}} \times \frac{1}{3} \Omega$$

where 100×10^{-9} = current/LSB

If R1, C2 are not used:

$$R4 = \frac{E_{DC}}{100 \times 10^{-9}} \Omega$$

where E_{DC} = 160×10^{-3} for 10 bits resolution

= 40×10^{-3} for 12 bits

= 10×10^{-3} for 14 bits

= 2.5×10^{-3} for 16 bits

= Scaling of the DC ERROR in volts/LSB

3. AC Coupling of Reference Input (R3, C3)

Select R3 and C3 so that there is no significant phase shift at the reference frequency. That is,

$$R3 = 100 \text{ k}\Omega$$

$$C3 > \frac{1}{R3 \times f_{REF}} F$$

with R3 in Ω .

4. Maximum Tracking Rate (R6)

The VCO input resistor R6 sets the maximum tracking rate of the converter and hence the velocity scaling as at the max tracking rate, the velocity output will be 8 V.

Decide on your maximum tracking rate, “T,” in revolutions per second. When setting the value for R6, it should be remembered that the linearity of the velocity output is specified across 0 kHz–500 kHz and 500 kHz–1000 kHz. The following conversion can be used to determine the corresponding rps:

$$rps = \frac{VCO \text{ Rate (Hz)}}{2^N}$$

Note that “T” must not exceed the maximum tracking rate or 1/16 of the reference frequency.

$$R6 = \frac{6.81 \times 10^{10}}{T \times n} \Omega$$

where n = bits per revolution

= 1,024 for 10 bits resolution

= 4,096 for 12 bits

= 16,384 for 14 bits

= 65,536 for 16 bits

5. Closed-Loop Bandwidth Selection (C4, C5, R5)

a. Choose the closed-loop bandwidth (f_{BW}) required ensuring that the ratio of reference frequency to bandwidth does not exceed the following guidelines:

Resolution	Ratio of Reference Frequency/Bandwidth
10	2.5 : 1
12	4 : 1
14	6 : 1
16	7.5 : 1

Typical values may be 100 Hz for a 400 Hz reference frequency and 500 Hz to 1000 Hz for a 5 kHz reference frequency.

b. Select C4 so that

$$C4 = \frac{21}{R6 \times f_{BW}^2} F$$

with R6 in Ω and f_{BW} , in Hz selected above.

c. C5 is given by

$$C5 = 5 \times C4$$

d. R5 is given by

$$R5 = \frac{4}{2 \times \pi \times f_{BW} \times C5} \Omega$$

6. VCO Phase Compensation

The following values of C6 and R7 should be connected as close as possible to the VCO output, Pin 41.

$$C6 = 390 \text{ pF}, R7 = 3.3 \text{ k}\Omega$$

7. VCO Optimization

To optimize the performance of the VCO a capacitor, C7, should be placed across the VCO input and output, Pins 40 and 41.

$$C7 = 150 \text{ pF}$$

8. Offset Adjust

Offsets and bias currents at the integrator input can cause an additional positional offset at the output of the converter of 1 arc minute typical, 5.3 arc minutes maximum. If this can be tolerated, then R8 and R9 can be omitted from the circuit.

If fitted, the following values of R8 and R9 should be used:

$$R8 = 4.7 \text{ M}\Omega, R9 = 1 \text{ M}\Omega \text{ potentiometer}$$

To adjust the zero offset, ensure the resolver is disconnected and all the external components are fitted. Connect the COS pin to the REFERENCE INPUT and the SIN pin to the SIGNAL GROUND and with the power and reference applied, adjust the potentiometer to give all "0s" on the digital output bits.

The potentiometer may be replaced with select on test resistors if preferred.

DATA TRANSFER

To transfer data the $\overline{\text{INHIBIT}}$ input should be used. The data will be valid 490 ns after the application of a logic "LO" to the $\overline{\text{INHIBIT}}$. This is regardless of the time when the $\overline{\text{INHIBIT}}$ is applied and allows time for an active BUSY to clear. By using the $\overline{\text{ENABLE}}$ input the two bytes of data can be transferred after which the $\overline{\text{INHIBIT}}$ should be returned to a logic "HI" state to enable the output latches to be updated.

BUSY Output

The validity of the output data is indicated by the state of the BUSY output. When the input to the converter is changing, the signal appearing on the BUSY output is a series of pulses at TTL level. A BUSY pulse is initiated each time the input moves by the analog equivalent of one LSB and the internal counter is incremented or decremented.

$\overline{\text{INHIBIT}}$ Input

The $\overline{\text{INHIBIT}}$ logic input only inhibits the data transfer from the up-down counter to the output latches and, therefore, does not interrupt the operation of the tracking loop. Releasing the $\overline{\text{INHIBIT}}$ automatically generates a BUSY pulse to refresh the output data.

$\overline{\text{ENABLE}}$ Input

The $\overline{\text{ENABLE}}$ input determines the state of the output data. A logic "HI" maintains the output data pins in the high impedance condition, and the application of a logic "LO" presents the data in the latches to the output pins. The operation of the $\overline{\text{ENABLE}}$ has no effect on the conversion process.

BYTE SELECT Input

The BYTE SELECT input selects the byte of the position data to be presented at the data output DB1 to DB8. The least significant byte will be presented on data output DB9 to DB16 (with the $\overline{\text{ENABLE}}$ input taken to a logic "LO") regardless of the state of the BYTE SELECT pin. Note that when the AD2S83 is used with a resolution less than 16 bits the unused data lines are pulled to a logic "LO." A logic "HI" on the BYTE SELECT input will present the eight most significant data bits on data output DB1 and DB8. A logic "LO" will present the least significant byte on data outputs 1 to 8, i.e., data outputs 1 to 8 will duplicate data outputs 9 to 16.

The operation of the BYTE SELECT has no effect on the conversion process of the converter.

RIPPLE CLOCK

As the output of the converter passes through the major carry, i.e., all "1s" to all "0s" or the converse, a positive going edge on the RIPPLE CLOCK (RC) output is initiated indicating that a revolution, or a pitch, of the input has been completed.

The minimum pulsewidth of the ripple clock is 300 ns. RIPPLE CLOCK is normally set high before a BUSY pulse and resets before the next positive going edge of the next BUSY pulse.

The only exception to this is when DIR changes while the RIPPLE CLOCK is high. Resetting of the RIPPLE clock will only occur if the DIR remains stable for two consecutive positive BUSY pulse edges.

If the AD2S83 is being used in a pitch and revolution counting application, the ripple and busy will need to be gated to prevent false decrement or increment (see Figure 2).

RIPPLE CLOCK is unaffected by $\overline{\text{INHIBIT}}$.

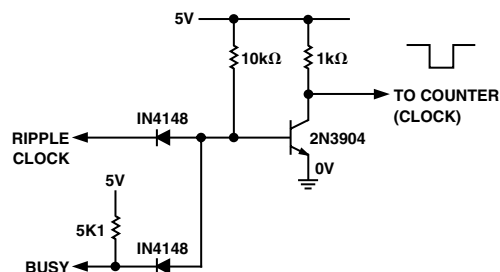

NOTE: DO NOT USE ABOVE CCT WHEN $\overline{\text{INHIBIT}}$ IS LOW.

Figure 2. Diode Transistor Logic N and Gate

AD2S83

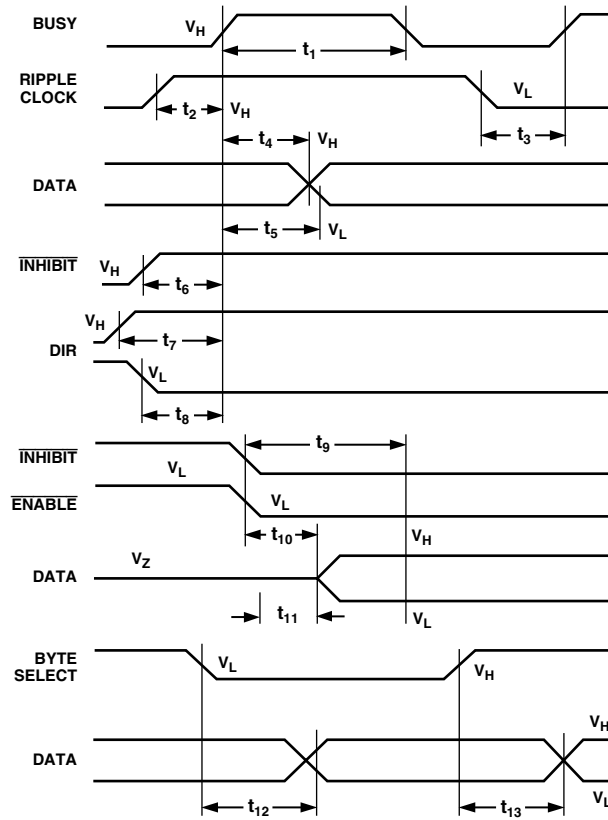

Figure 3. Digital Timing

Parameter	T _{MIN} *	T _{MAX} *	Condition
t ₁	150	350	BUSY WIDTH V _H -V _H
t ₂	10	25	RIPPLE CLOCK V _H to BUSY V _H
t ₃	470	580	RIPPLE CLOCK V _L to Next BUSY V _H
t ₄	16	45	BUSY V _H to DATA V _H
t ₅	3	25	BUSY V _H to DATA V _L
t ₆	70	140	$\overline{\text{INHIBIT}}$ V _H to BUSY V _H
t ₇	485	625	MIN DIR V _H to BUSY V _H
t ₈	515	670	MIN DIR V _H to BUSY V _H
t ₉	-	490	$\overline{\text{INHIBIT}}$ V _L to DATA STABLE
t ₁₀	40	110	$\overline{\text{ENABLE}}$ V _L to DATA V _H
t ₁₁	35	110	$\overline{\text{ENABLE}}$ V _L to DATA V _L
t ₁₂	60	140	BYTE SELECT V _L to DATA STABLE
t ₁₃	60	125	BYTE SELECT V _H to DATA STABLE

*ns

DIRECTION Output

The DIRECTION (DIR) output indicates the direction of the input rotation. Any change in the state of DIR precedes the corresponding BUSY, DATA and RIPPLE CLOCK updates. DIR can be considered as an asynchronous output and can make multiple changes in state between two consecutive LSB update cycles. This occurs when the direction of rotation of the input changes but the magnitude of the rotation is less than 1 LSB.

COMPLEMENT

The $\overline{\text{COMPLEMENT}}$ input is an active low input and is internally pulled to $+V_S$ via 100 k Ω .

Strobing $\overline{\text{DATA LOAD}}$ and $\overline{\text{COMPLEMENT}}$ pins to logic LO will set the logic HI bits of the AD2S83 counter to a LO state. Those bits of the applied data which are logic LO will not change the corresponding bits in the AD2S83 counter.

For Example:

Initial Counter State	1 0 1 0 1
Applied Data Word	1 1 0 0 0
Counter State after $\overline{\text{DATA LOAD}}$	1 1 0 0 0
Initial Counter State	1 0 1 0 1
Applied Data Word	1 1 0 0 0
Counter State after $\overline{\text{DATA LOAD}}$ and Complement	0 0 1 0 1

In order to read the counter following a $\overline{\text{DATA LOAD}}$, the procedure below should be followed:

1. Place outputs in high impedance state ($\overline{\text{ENABLE}} = \text{HI}$).
2. Present data to pins.
3. Pull $\overline{\text{DATA LOAD}}$ and $\overline{\text{COMPLEMENT}}$ pins to ground.
4. Wait 100 ns.
5. Remove data from pins.
6. Remove outputs from high impedance state ($\overline{\text{ENABLE}} = \text{LO}$).
7. Read outputs.

CIRCUIT FUNCTIONS AND DYNAMIC PERFORMANCE

The AD2S83 allows the user great flexibility in choosing the dynamic characteristics of the resolver-to-digital conversion to ensure the optimum system performance. The characteristics are set by the external components shown in Figure 1. The Component Selection section explains how to select desired maximum tracking rate and bandwidth values. The following paragraphs explain in greater detail the circuit of the AD2S83 and the variations in the dynamic performance available to the user.

Loop Compensation

The AD2S83 (connected as shown in Figure 1) operates as a Type 2 tracking servo loop where the VCO/counter combination and Integrator perform the two integration functions inherent in a Type 2 loop.

Additional compensation in the form of a pole/zero pair is required to stabilize the loop.

This compensation is implemented by the integrator components (R4, C4, R5, C5).

The overall response the converter is that of a unity gain second order low-pass filter, with the angle of the resolver as the input and the digital position data as the output.

The AD2S83 does not have to be connected as tracking converter, parts of the circuit can be used independently. This is particularly true of the Ratio Multiplier which can be used as a control transformer. (For more information contact Motion Control Applications.)

A block diagram of the AD2S83 is given in Figure 4.

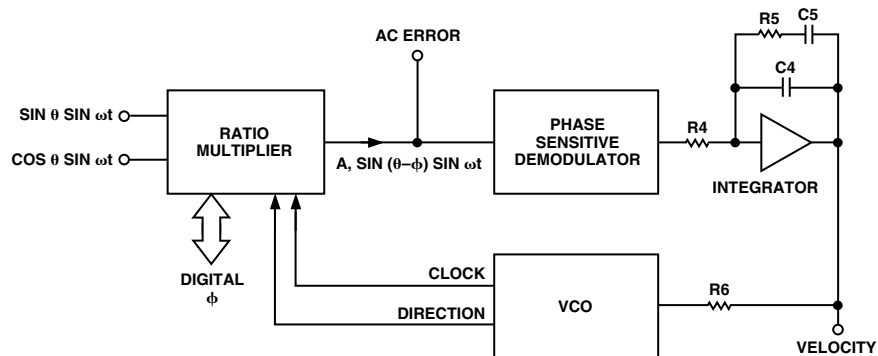

Figure 4. Functional Diagram

AD2S83

Ratio Multiplier

The ratio multiplier is the input section of the AD2S83. This compares the signal from the resolver (angle θ) to the digital (angle ϕ) held in the counter. Any difference between these two angles results in an analog voltage at the AC ERROR OUTPUT. This circuit function has historically been called a “Control Transformer” as it was originally performed by an electromechanical device known by that name.

The AC ERROR signal is given by

$$A1 \sin(\theta - \phi) \sin \omega t$$

where $\omega = 2 \pi f_{\text{REF}}$

f_{REF} = reference frequency

A1 = the gain of the ratio multiplier stage = 14.5.

So for 2 V rms inputs signals

AC ERROR output in volts/(bit of error)

$$= 2 \times \sin\left(\frac{360}{n}\right) \times A1$$

where n = bits per rev

= 1,024 for 10-bit resolution

= 4,096 for 12-bit resolution

= 16,384 for 14-bit resolution

= 65,536 for 16-bit resolution

giving an AC ERROR output

= 178 mV/bit @ 10-bit resolution

= 44.5 mV/bit @ 12-bit resolution

= 11.125 mV/bit @ 14-bit resolution

= 2.78 mV/bit @ 16-bit resolution

The ratio multiplier will work in exactly the same way whether the AD2S83 is connected as a tracking converter or as a control transformer, where data is preset into the counters using the DATA LOAD pin.

HF Filter

The AC ERROR OUTPUT may be fed to the PSD via a simple ac coupling network (R2, C1) to remove any dc offset at this point. Note, however, that the PSD of the AD2S83 is a wide-band demodulator and is capable of aliasing HF noise down to within the loop bandwidth. This is most likely to happen where the resolver is situated in particularly noisy environments, and the user is advised to fit a simple HF filter R1, C2 prior to the phase sensitive demodulator.

The attenuation and frequency response of a filter will affect the loop gain and must be taken into account in deriving the loop transfer function. The suggested filter (R1, C1, R2, C2) is shown in Figure 1 and gives an attenuation at the reference frequency (f_{REF}) of three times at the input to the phase sensitive demodulator.

Values of components used in the filter must be chosen to ensure that the phase shift at f_{REF} is within the allowable signal to reference phase shift of the converter.

Phase Sensitive Demodulator

The phase sensitive demodulator is effectively ideal and develops a mean dc output at the DEMODULATOR OUTPUT pin of

$$\frac{\pm 2 \sqrt{2}}{\pi} \times (\text{DEMODULATOR INPUT rms voltage})$$

for sinusoidal signals in phase or antiphase with the reference (for a square wave the DEMODULATOR OUTPUT voltage will equal the DEMODULATOR INPUT). This provides a signal at the DEMODULATOR OUTPUT which is a dc level proportional to the positional error of the converter.

DC Error Scaling = 160 mV/bit (10-bit resolution)

= 40 mV/bit (12-bit resolution)

= 10 mV/bit (14-bit resolution)

= 2.5 mV/bit (16-bit resolution)

When the tracking loop is closed, this error is nulled to zero unless the converter input angle is accelerating.

Integrator

The integrator components (R4, C4, R5, C5) are external to the AD2S83 to allow the user to determine the optimum dynamic characteristics for any given application. The Component Selection section explains how to select components for a chosen bandwidth.

Since the output from the integrator is fed to the VCO INPUT, it is proportional to velocity (rate of change of output angle) and can be scaled by selection of R6, the VCO input resistor. This is explained in the Voltage Controlled Oscillator (VCO) section below.

To prevent the converter from “flickering” (i.e., continually toggling by ± 1 bit when the quantized digital angle, ϕ , is not an exact representation of the input angle, θ) feedback is internally applied from the VCO to the integrator input to ensure that the VCO will only update the counter when the error is greater than or equal to 1 LSB. In order to ensure that this feedback “hysteresis” is set to 1 LSB the input current to the integrator must be scaled to be 100 nA/bit. Therefore,

$$R4 = \frac{\text{DC Error Scaling (mV/bit)}}{100 \text{ (nA/bit)}}$$

Any offset at the input of the integrator will affect the accuracy of the conversion as it will be treated as an error signal and offset the digital output. One LSB of extra error will be added for each 100 nA of input bias current. The method of adjusting out this offset is given in the Component Selection section.

Voltage Controlled Oscillator (VCO)

The VCO is essentially a simple integrator feeding a pair of dc level comparators. Whenever the integrator output reaches one of the comparator threshold voltages, a fixed charge is injected into the integrator input to balance the input current. At the same time the counter is clocking either up or down, dependent on the polarity of the input current. In this way the counter is clocked at a rate proportional to the magnitude of the input current of the VCO.

During the VCO reset period the input continues to be integrated. The reset period is constant at 40 ns.

The VCO rate is fixed for a given input current by the VCO scaling factor:

$$= 8.5 \text{ kHz}/\mu\text{A}$$

The tracking rate in rps per μA of VCO input current can be found by dividing the VCO scaling factor by the number of LSB changes per rev (i.e., 4096 for 12-bit resolution).

The input resistor R6 determines the scaling between the converter velocity signal voltage at the INTEGRATOR OUTPUT pin and the VCO input current. Thus to achieve a 5 V output at 100 rps (6000 rpm) and 12-bit resolution the VCO input current must be:

$$(100 \times 4096)/(8500) = 48.2 \mu\text{A}$$

Thus, R6 would be set to: $5/(48.2 \times 10^{-6}) = 103.7 \text{ k}\Omega$

The velocity offset voltage depends on the VCO input resistor, R6, and the VCO bias current and is given by

$$\text{Velocity Offset Voltage} = R6 \times (\text{VCO bias current})$$

The temperature coefficient of this offset is given by

$$\text{Velocity Offset Tempco} = R6 \times (\text{VCO bias current tempco})$$

where the VCO bias current tempco is typically $+0.22 \text{ nA}/^\circ\text{C}$.

The maximum recommended rate for the VCO is 1.1 MHz which sets the maximum possible tracking rate.

Since the minimum voltage swing available at the integrator output is $\pm 8 \text{ V}$, this implies that the minimum value for R6 is 62 k Ω . As

$$\text{Max Current} = \frac{1.1 \times 10^6}{8.5 \times 10^3} = 129 \mu\text{A}$$

$$\text{Min Value R6} = \frac{8}{129 \times 10^{-6}} = 62 \text{ k}\Omega$$

Transfer Function

By selecting components using the method outlined in the section "Component Selection," the converter will have a critically damped time response and maximum phase margin. The Closed-Loop Transfer Function is given by:

$$\frac{\theta_{OUT}}{\theta_{IN}} = \frac{14(1 + s_N)}{(s_N + 2.4)(s_N^2 + 3.4s_N + 5.8)}$$

where, s_N , the normalized frequency variable is given by:

$$s_N = \frac{2}{\pi} \frac{s}{f_{BW}}$$

and f_{BW} is the closed-loop 3 dB bandwidth (selected by the choice of external components).

The acceleration constant K_A , is given approximately by

$$K_A = 6 \times (f_{BW})^2 \text{ sec}^{-2}$$

The normalized gain and phase diagrams are given in Figures 5 and 6.

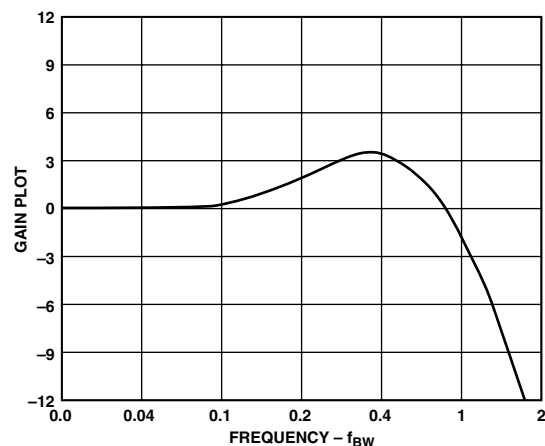

Figure 5. Gain Plot

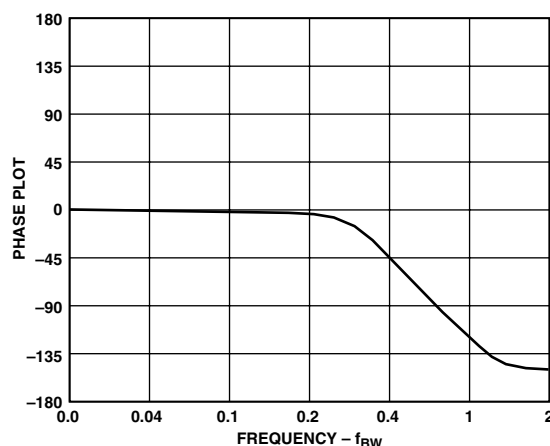

Figure 6. Phase Plot

AD2S83

The small signal step response is shown in Figure 7. The time from the step to the first peak is t_1 , and the t_2 is the time from the step until the converter is settled to 1 LSB. The times t_1 and t_2 are given approximately by

$$t_1 = \frac{1}{f_{BW}}$$

$$t_2 = \frac{5}{f_{BW}} \times \frac{R}{12}$$

where R = resolution, i.e., 10, 12, 14 or 16.

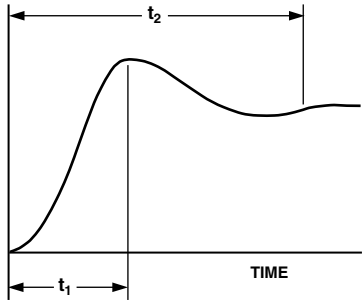

Figure 7. Small Step Response

The large signal step response (for steps greater than 5 degrees) applies when the error voltage exceeds the linear range of the converter.

Typically the converter will take three times longer to reach the first peak for a 179 degrees step.

In response to a velocity step, the velocity output will exhibit the same time response characteristics as outlined above for the position output.

THE AD2S83 AS A SILICON TACHOGENERATOR

Position Control Using the AD2S83

The AD2S83 has been optimized for use as a feedback device for velocity as well as position. A traditional position control loop shown below compares a demand position with an actual to derive a position error and hence a velocity demand.

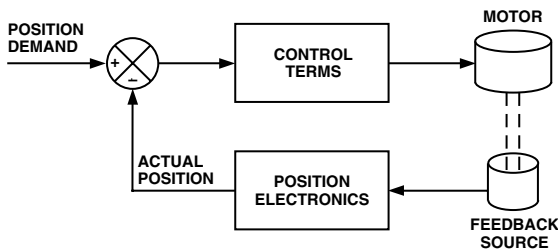

Figure 8. Position Control

Quality of control may be reduced if the load on a motor varies dynamically. System reaction and compensation for a sudden change in the loading depends on how rapidly the system can update the velocity demand to the motor. This can cause rapid acceleration of the motor until the loop updates with a new velocity demand.

The only effective way to compensate for dynamic loading effects is to introduce a 2nd order term which will provide the motor with an acceleration or deceleration demand signal (see Figure 9).

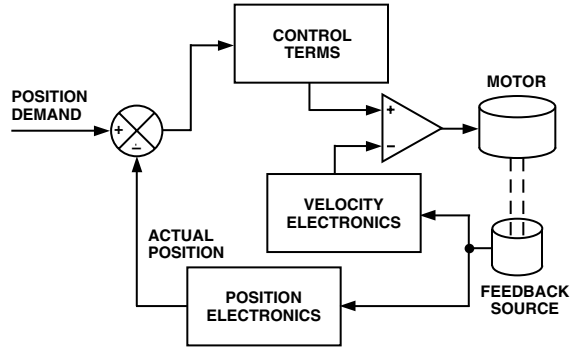

Figure 9. Position Control and Velocity Control

Traditionally this would need to be implemented by using separate position and speed feedback transducers, e.g., an encoder or resolver and a dc tachogenerator. The AD2S83 can decode the resolver to provide both velocity and position information.

DC Tachogenerator

The DC tachogenerator is a small permanent magnet dc generator. The output is a dc voltage which is proportional to the speed of the rotor and whose polarity is determined by the direction of rotation. Physically they are similar to a resolver.

Velocity Error Derivation

The velocity error is the difference between the synthesized dc velocity demand derived from the actual and demand positions and the feedback from the tachogenerator or the AD2S83. The velocity demand is usually derived via a DAC so apart from any quantization noise it is clean. The velocity feedback, therefore, needs to be as close to a pure dc level as possible. The errors which determine the quality of the resultant acceleration demand to the motor are explained below.

Linearity

Linearity is the maximum deviation from the ideal straight line velocity characteristic. The line used is given by:

$$v = mx + c$$

where

- v = velocity
- m = gain scaling
- x = dc voltage
- c = zero velocity dc offset

Linearity is generally a function of the input velocity to the tachogenerator or resolver.

Reversion Error

Reversion or reversal error is an offset which is dependent on the direction of rotation of the transducer; e.g., if 10 rps = 1.000 V dc, then -10 rps = 1.003 V dc with +0.3% reversion error and FSO = ±8 V dc.

Zero Velocity DC Offset

This is a residual dc offset present at zero input velocity. This can be externally nulled.

Ripple Content

Ripple content is due to several factors. Tachogenerators suffer from ripple due to the speed of rotation, commutator segments and the number of poles. The resolver/RDC combination has a predominant ripple at twice the resolver reference as a result of the synchronous demodulator and at a frequency twice per revolution due to the resolver windings mismatch.

Motor torque pulsations which are a consequence of excessive velocity ripple have a detrimental effect upon the quality of speed control in servo systems.

The resultant “cogging” effect will be particularly noticeable at low speed and when the motor is in the low torque region.

Other undesirable side effects such as the increase in acoustic noise from a motor and a temperature rise in the motor stator windings are possible results of the presence of torque ripple.

For more detailed information of the causes and sources of errors see the Velocity Errors section.

AD2S83 COMPARISON WITH DC TACHOGENERATOR

Comparative tests of the AD2S83 and a dc tachogenerator were carried out. The tachogenerator was connected at the nondrive end of the motor shaft with the resolver located behind the drive shaft of the motor. The AD2S83 was located remotely. The AD2S83 was set up with a 200 Hz bandwidth, reference frequency of 2.6 kHz and resolution of 14 bits.

The comparative analysis can be summarized:

	AD2S83	DC Tacho	Conditions
Linearity %	0.1	0.1	0-3600 rpm
Reversion Error % FSO	0.3	0.25	

Note the typical operating range of dc tachogenerator is 0 rpm-3600 rpm. The resolver/AD2S83 combination will operate up to speeds in excess of 10000 rpm.

Ripple Effects

The comparative analysis of the output ripple from the tachogenerator and the AD2S83 is illustrated below.

Minimization of the AD2S83 output ripple is discussed in detail in the Velocity Errors section.

Other Factors

Other factors concerning choice of feedback source have to be addressed. On average the MTBF of a tachogenerator is 347 days as opposed to typically 8 years for a resolver. Resolvers are relatively insensitive to temperature whereas a tachogenerator will be specified up to a maximum of 100°C with a ±0.1%/°C (above 25°C) degradation in output voltage. The brushless resolver requires no preventative maintenance; the brushes on a tachogenerator, however, will require periodic checking.

ACCELERATION ERROR

A tracking converter employing a Type 2 servo loop does not suffer any velocity lag, however, there is an additional error due to acceleration. This additional error can be defined using the acceleration constant K_A of the converter.

$$K_A = \frac{\text{Input Acceleration}}{\text{Error in Output Angle}}$$

The numerator and denominator must have consistent angular units. For example if K_A is in sec^{-2} , then the input acceleration may be specified in degrees/sec^2 and the error output in degrees.

K_A does not define maximum input acceleration, only the error due to acceleration. The maximum acceleration allowable before the converter loses track is dependent on the angular accuracy requirements of the system.

$$\text{Angular Accuracy} \times K_A = \text{Degrees/sec}^2$$

K_A can be used to predict the output position error for a given input acceleration. For example for an acceleration of 100 revs/sec^2 , $K_A = 2.7 \times 10^6 \text{ sec}^{-2}$ and 12-bit resolution.

$$\text{Error in LSBs} = \frac{\text{Input acceleration [LSB/sec}^2\text{]}}{K_A [\text{sec}^{-2}]}$$

$$= \frac{100 [\text{rev/sec}^2] \times 2^{12}}{2.7 \times 10^6} = 0.15 \text{ LSBs or } 47.5 \text{ seconds of arc}$$

To determine the value of K_A based on the passive components used to define the dynamics of the converter the following should be used.

$$K_A = \frac{4.04 \times 10^{11}}{2^n \times R6 \times R4 \times (C4 + C5)}$$

Where n = resolution of the converter.

R4, R6 in ohms

C5, C4 in farads.

AD2S83

SOURCES OF ERRORS

Integrator Offset

Additional inaccuracies in the conversion of the resolver signals will result from an offset at the input to the integrator. This offset will be treated as an error signal. The resulting angular error will typically be 1 arc minute over the operating temperature range.

A description of how to adjust the zero offset is given in the Component Selection section; the circuit required is shown in Figure 1.

Differential Phase Shift

Phase shift between the sine and cosine signals from the resolver is known as differential phase shift and can cause static error. Some differential phase shift will be present on all resolvers as a result of coupling. A small resolver residual voltage (quadrature voltage) indicates a small differential phase shift. Additional phase shift can be introduced if the sine channel wires and the cosine channel wires are treated differently. For instance, different cable lengths or different loads could cause differential phase shift.

The additional error caused by differential phase shift on the input signals approximates to

$$\text{Error} = 0.53 a \times b \text{ arc minutes}$$

where a = differential phase shift (degrees).

b = signal to reference phase shift (degrees).

This error can be minimized by choosing a resolver with a small residual voltage, ensuring that the sine and cosine signals are handled identically and removing the reference phase shift (see the Connecting the Resolver section). By taking these precautions the extra error can be made insignificant.

Most resolvers exhibit a phase shift between the signal and the reference. This phase shift will, however, give rise under dynamic conditions to an additional error defined by:

$$\frac{\text{Shaft Speed (rps)} \times \text{Phase Shift (Degrees)}}{\text{Reference Frequency}} = \text{Error Degrees}$$

Under static operating conditions phase shift between the reference and the signal lines alone will not theoretically affect the converter's static accuracy.

For example, for a phase shift of 20 degrees, a shaft rotation of 22 rps and a reference frequency of 5 kHz, the converter will exhibit an additional error of:

$$\frac{22 \times 20}{5000} = 0.088 \text{ Degrees}$$

This effect can be eliminated by placing a phase shift in the reference to the converter equivalent to the phase shift in the resolver (see the Connecting the Resolver section).

Note: Capacitive and inductive crosstalk in the signal and reference leads and wiring can cause similar problems.

VELOCITY ERRORS

Some "ripple" or noise will always be present in the velocity signal. Velocity signal ripple is caused by, or related to, the following parameters. The resulting effects are generally additive. This means diagnosis needs to be an iterative process in order to define the source of the error.

1.0 Reference Frequency

A ripple content at the reference frequency is superimposed on the velocity signal output. The amplitude depends on the loop bandwidth. This error is a function of a dc offset at the input to Phase Sensitive Demodulator (PSD).

2.0 Resolver Inaccuracies

Impedance mismatch occur in the sine and cosine windings of the resolver. These give rise to differential phase shift between the sine and cosine inputs to the RDC and variations in the resolver output amplitudes.

2.1 Sine and Cosine Amplitude Mismatch

This is normally identified by the presence of asymmetrical ripple voltages.

2.2 Differential Phase Shift between the Sine and Cosine Inputs

The frequency of this ripple is usually twice the input velocity, and the amplitude is proportional to the magnitude of the velocity signal. The phase shift is normally induced through the connections from the resolver to the converter. Maintaining equal lengths of screened twisted pair cable from the resolver to the AD2S83 will reduce the effects of resistive imbalance, and therefore, reduce differential phase shift.

3.0 LSB Update Ripple

LSB update noise occurs as the resolver rotates and the digital outputs of the RDC are updated. For a correctly scaled loop, this ripple component has a magnitude of approximately 2 mV peak at 16-bit resolution.

3.1 Ripple due to the LSB rate given by:

$$\text{LSB rate} = N \times \text{Reference Frequency}$$

The PSD generates sums and differences of all its component input frequencies, so when the LSB update rate is an multiple of the reference frequency, a beat frequency is generated. The magnitude of this ripple is a function of the LSB weighting, i.e., ripple is less at 16 bits.

4.0 Torque Ripple

Torque ripple is a phenomenon associated with motors. An ac motor naturally exhibits a sinusoidal back emf. In an ideal system the current fed to the motor should, in order to cancel, also be sinusoidal. In practice the current is often trapezoidal. Consequently, the output torque from the motor will not be smooth and torque ripple is created. If the loading on a motor is constant, the velocity of the motor shaft will vary as a result of the cyclic variation of motor torque. The variation in velocity then appears on the velocity output as ripple. This is not an error but a true velocity variation in the system.

Offset Errors

The limiting factor in the measuring of low or “creep” speeds is the level of dc offset present at zero velocity. The zero velocity dc offset at the output of the AD2S83 is a function of the input bias current to the VCO and the value for the input resistor R6. See “Circuit Functions and Dynamic Performance VCO.”

The offset can be minimized by reducing the maximum tracking rate so reducing the value for R6. Offset is a function of tracking rate and therefore resolution; the dc offset is lowest at 16 bits. To increase the dynamic range of the velocity dynamic resolution switching can be employed. (Contact MCG Applications for more information.)

CONNECTING THE RESOLVER

The recommended connection circuit is shown in Figure 11.

In cases where the reference phase relative to the input signals from the resolver requires adjustment, this can be easily achieved by varying the value of the resistor R2 of the HF filter (see Figure 1).

Assume that $R1 = R2 = R$ and $C1 = C2 = C$

$$\text{and Reference Frequency} = \frac{1}{2\pi RC}$$

By altering the value of R2, the phase of the reference relative to the input signals will change in an approximately linear manner for phase shifts of up to 10 degrees.

Increasing R2 by 10% introduces a phase lag of two degrees.

Decreasing R2 by 10% introduces a phase lead of two degrees.

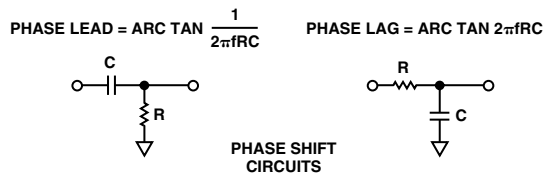

Figure 10. Phase Shift Circuits

TYPICAL CIRCUIT CONFIGURATION

Figure 11 shows a typical circuit configuration for the AD2S83 with 12-bit resolution. Values of the external components have been chosen for a reference frequency of 5 kHz and a maximum tracking rate of 260 rps with a bandwidth of 520 Hz. Placing the values for R4, R6, C4, and C5 in the equation for K_A gives a value of 1.65×10^6 . The resistors are 0.125 W, 5% tolerance preferred values. The capacitors are 100 V ceramic, 10% tolerance components.

For signal and reference voltages greater than 2 V rms a simple voltage divider circuit of resistors can be used to generate the correct signal level at the converter. Care should be taken to ensure that the ratios of the resistors between the sine signal line and ground and the cosine signal line and ground are the same. Any difference will result in an additional position error.

For more information on resistive scaling of SIN, COS, and REFERENCE converter inputs refer to the application note, “Circuit Applications of the 2S81 and 2S80 Resolver-to-Digital Converters.”

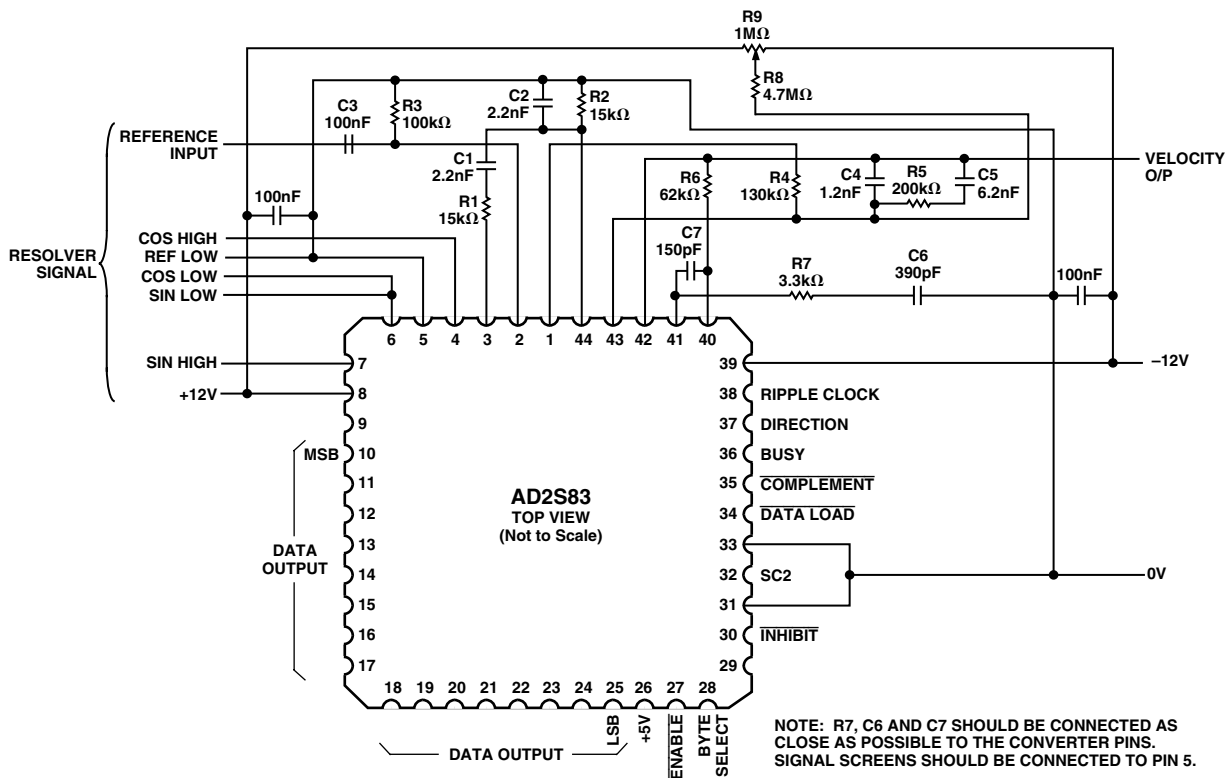

Figure 11. Typical Circuit Configuration

AD2S83

APPLICATIONS

Control Transformer

The ratio multiplier of the AD2S83 can be used independently of the loop integrators as a control transformer. In this mode, the resolver inputs θ are multiplied by a digital angle ϕ , any difference between ϕ and θ will be represented by the AC ERROR output as $\sin \omega t \sin (\theta-\phi)$ or the DEMOD output as $\sin (\theta-\phi)$. To use the AD2S83 in this mode refer to the “Control Transformer” application note.

OTHER PRODUCT

AD2S90. Low-cost resolver-to-digital converter with outputs which emulate optical encoders and a serial output for absolute position information. Unlike the AD2S83, the AD2S90 requires no external components to operate. The AD2S90 is built on LC²MOS and packaged in a 20-lead PLCC.

AD2S80A/AD2S81A/AD2S82A. Monolithic resolver-to-digital converter. The AD2S80/AD2S82A offer selectable 10, 12, 14, 16 bits of resolution. The AD2S81A has 12-bit resolution. All devices have user selectable dynamics. The AD2S80A is available in 40-lead DDIP, 44-lead LCC and is qualified to MIL-STD-883B REV. E. The is available in a 44-lead PLCC, and the AD2S81A in a 28-lead DDIP.

OUTLINE DIMENSIONS

Dimensions shown in inches and (mm).

**Plastic Leaded Chip Carrier (PLCC)
(P-44A)**

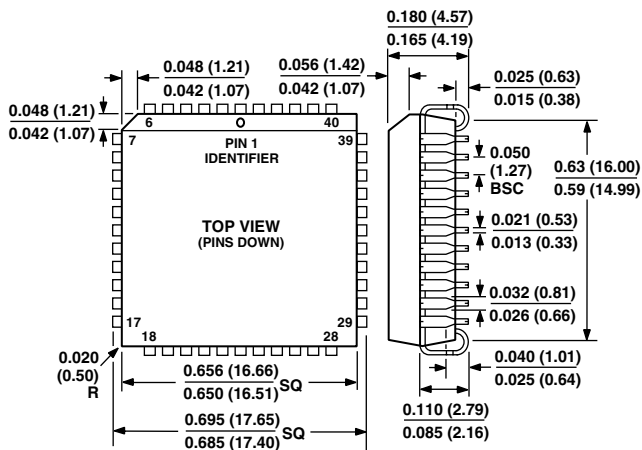

C00006c-1.5-10/00 (rev. E)

PRINTED IN U.S.A.