

EMG 15-LG/SET - Electronic housing



2942975

<https://www.phoenixcontact.com/us/products/2942975>

Please be informed that the data shown in this PDF document is generated from our online catalog. Please find the complete data in the user documentation. Our general terms of use for downloads are valid.



Electronic housing set, consisting of electronic housing and printed circuit termination blocks, pitch 5

Commercial data

Item number	2942975
Packing unit	1 pc
Minimum order quantity	10 pc
Sales key	AC11
Product key	ACHCBA
Catalog page	Page 709 (C-1-2013)
GTIN	4017918080938
Weight per piece (including packing)	28.8 g
Weight per piece (excluding packing)	28.8 g
Customs tariff number	85369010
Country of origin	DE

EMG 15-LG/SET - Electronic housing

2942975

<https://www.phoenixcontact.com/us/products/2942975>

Set consists of

EMG 15-LG - Electronic housing

2908508

<https://www.phoenixcontact.com/us/products/2908508>



Electronic housing, with universal foot, for PCB insertion, without screw connection terminal blocks and cover

MKDS 3/ 3-EMG 15 - PCB terminal block

1712698

<https://www.phoenixcontact.com/us/products/1712698>



PCB terminal block, nominal current: 24 A, rated voltage (III/2): 400 V, nominal cross section: 2.5 mm², number of potentials: 3, number of rows: 1, number of positions per row: 3, product range: MKDS 3, pitch: 5 mm, connection method: Screw connection with tension sleeve, screw head form: L Slotted, mounting: Wave soldering, conductor/PCB connection direction: 0 °, color: green, Pin layout: Linear pinning, Solder pin [P]: 5 mm, number of solder pins per potential: 1, type of packaging: packed in cardboard. Matches EMG 15 component housing

EMG 15-LG/SET - Electronic housing

2942975

<https://www.phoenixcontact.com/us/products/2942975>

Technical data

Product properties

Type	Lower housing part, removable cover as option, connection system integrated
Product type	Stackable housing set
Product family	EMG LG SET
Number of positions	6
Pitch	5 mm
Type	Lower and upper part, with universal foot, including PCB terminal blocks
Housing type	Component housing
Housing series	EMG

Dimensions

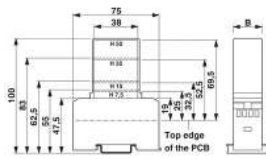
Dimensional drawing	
Width	15 mm
Installed height	47.5 mm
Height NS 35/7,5	55 mm 100 mm
Depth	75 mm
Length	75 mm
Pitch	5 mm

Material specifications

Color	green
Flammability rating according to UL 94	V0
Surface characteristics	untreated
Housing material	Polycarbonate, glass-fiber-reinforced

Environmental and real-life conditions

Ambient conditions

Degree of protection	IP20
Ambient temperature (operation)	-40 °C ... 125 °C

EMG 15-LG/SET - Electronic housing

2942975

<https://www.phoenixcontact.com/us/products/2942975>



Drawings

Dimensional drawing

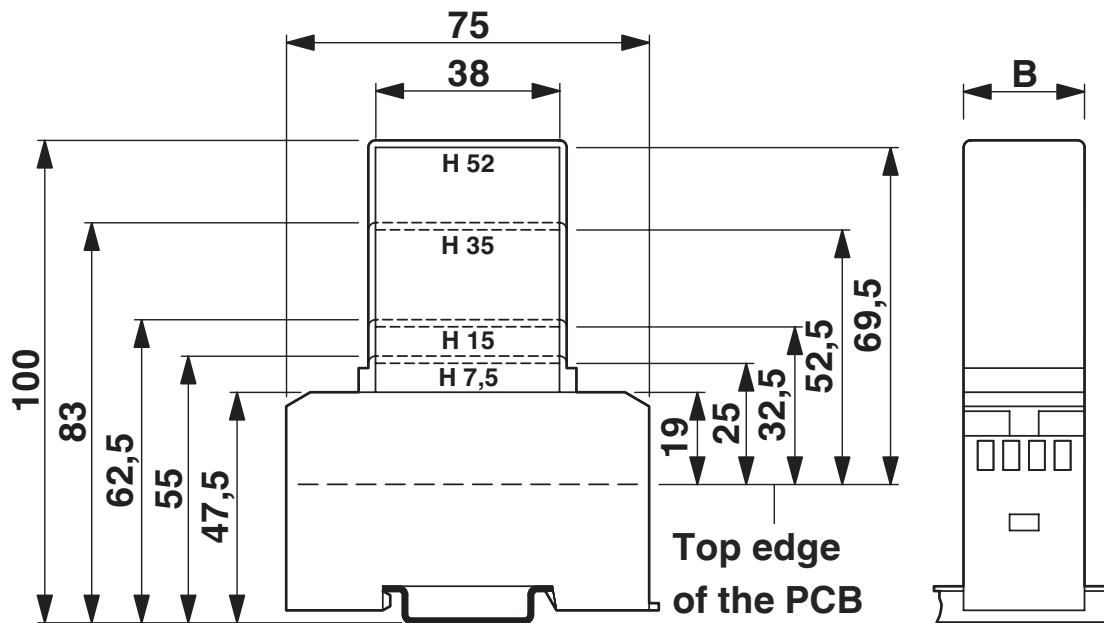

1 = Top edge of the PCB

B = Housing width

EMG 15-LG/SET - Electronic housing

2942975

<https://www.phoenixcontact.com/us/products/2942975>

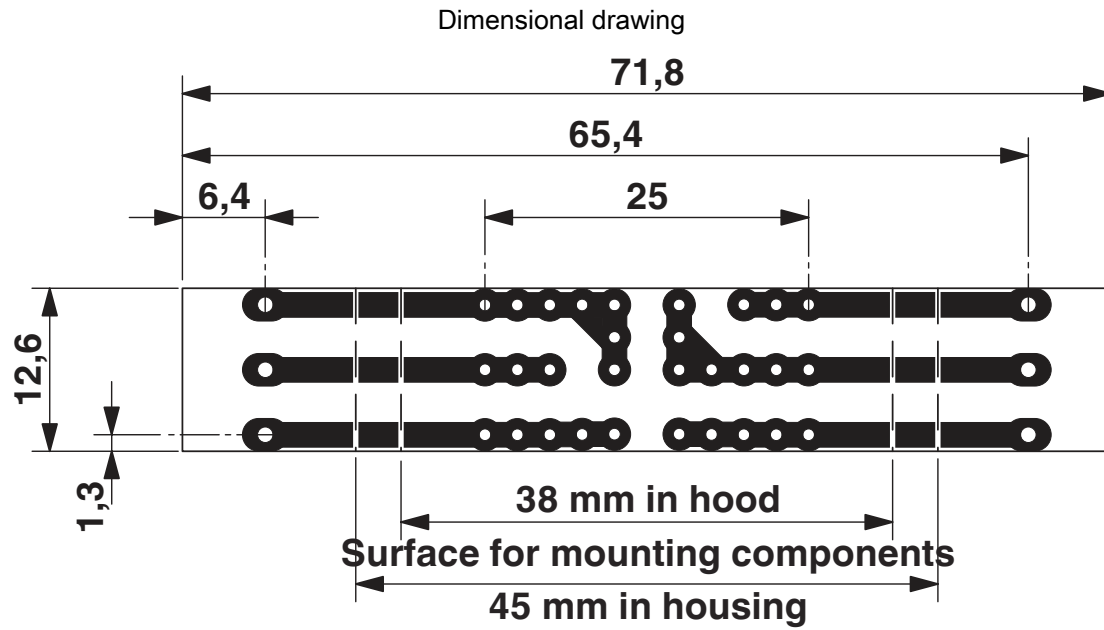

Pitch 5 mm

a = Area for mounting components, 38 mm in the hood

b = Area for mounting components, 45 mm in the housing

EMG 15-LG/SET - Electronic housing



2942975

<https://www.phoenixcontact.com/us/products/2942975>

Classifications

ECLASS

ECLASS-11.0	27182702
ECLASS-13.0	27190301

ETIM

ETIM 8.0	EC001031
----------	----------

UNSPSC

UNSPSC 21.0	31261500
-------------	----------

EMG 15-LG/SET - Electronic housing



2942975

<https://www.phoenixcontact.com/us/products/2942975>

Environmental product compliance

REACH SVHC	Lead 7439-92-1
China RoHS	Environmentally Friendly Use Period = 50 years
	For information on hazardous substances, refer to the manufacturer's declaration available under "Downloads"

EMG 15-LG/SET - Electronic housing

2942975

<https://www.phoenixcontact.com/us/products/2942975>



Mandatory accessories

EMG 15-H 7,5MM KLAR - Covering hood

2947828

<https://www.phoenixcontact.com/us/products/2947828>

Covering hood, for the contact and dust-protected encapsulation of the components, in transparent design. Height: 7.5 mm, width: 15 mm



EMG 15-H 15MM KLAR - Covering hood

2947831

<https://www.phoenixcontact.com/us/products/2947831>

Covering hood, for the contact and dust-protected encapsulation of the components, in transparent design. Height: 15 mm, width: 15 mm



EMG 15-LG/SET - Electronic housing

2942975

<https://www.phoenixcontact.com/us/products/2942975>



EMG 15-H 52MM GN - Covering hood

2947844

<https://www.phoenixcontact.com/us/products/2947844>



Covering hood, for the contact and dust-protected encapsulation of the components, in green design. Height: 52 mm, width: 15 mm

Accessories

EMG-KA - Cover

2941510

<https://www.phoenixcontact.com/us/products/2941510>



Terminal block/screw cover, set consisting of 50 strips each for terminal blocks and screw openings, 1 strip covers 12 terminal points.

EMG 15-LG/SET - Electronic housing

2942975

<https://www.phoenixcontact.com/us/products/2942975>



EMG-GKS 12 - Marking material

2947035

<https://www.phoenixcontact.com/us/products/2947035>



Device marking label, width: 12 mm, area: 12 x 8 mm, e.g. for EML(10x7) R adhesive marking material

P 1-EMG 15 - PCB

2947857

<https://www.phoenixcontact.com/us/products/2947857>



PCB for assembling electronic components

Phoenix Contact 2023 © - all rights reserved
<https://www.phoenixcontact.com>

Phoenix Contact USA
586 Fulling Mill Road
Middletown, PA 17057, United States
(+717) 944-1300
info@phoenixcon.com