

## DLP4710 0.47 1080p DMD

### 1 Features

- 0.47-Inch (11.93-mm) Diagonal Micromirror Array
  - 1920 × 1080 Array of Aluminum Micrometer-Sized Mirrors, in an Orthogonal Layout
  - Micron Micromirror Pitch: 5.4
  - Micromirror Tilt (Relative to Flat Surface):  $\pm 17^\circ$
  - Bottom Illumination for Optimal Efficiency and Optical Engine Size
  - Polarization Independent Aluminum Micromirror Surface
- 32-Bit SubLVDS Input Data Bus
- Dedicated DLPC3439 or DLP3479 Light and Display Controllers
- Dedicated DLPA3000 or DLPA3005 PMIC/LED Drivers for Reliable Operation

### 2 Applications

- Smart Full HD Projector
- Mobile Accessory Full HD Projector
- Screenless Display
- Interactive Display
- Low Latency Gaming Display
- Head Mounted Display

### 3 Description

The DLP4710 digital micromirror device (DMD) is a digitally controlled micro-opto-electromechanical system (MOEMS) spatial light modulator (SLM). When coupled to an appropriate optical system, the [DLP4710](#) DMD displays a very crisp and high quality image or video. The device is a component of the chipset comprising the DLP4710 DMD, [DLPC3439](#) or [DLPC3479](#) controller and [DLPA3000/DLPA3005](#) PMIC/LED drivers. The compact physical size of the DLP4710 coupled with the controller and the PMIC/LED driver provides a complete system solution that enables small form factor, low power, and high resolution HD displays.

Visit the [getting started with TI DLP® Pico™ display technology](#) page to learn how to get started with the DLP4710.

The DLP4710 ecosystem includes established resources to help the user accelerate the design cycle, which include [production ready optical modules](#), [optical modules manufactures](#), and [design houses](#).

#### Device Information<sup>(1)</sup>

PART NUMBER	PACKAGE	BODY SIZE (NOM)
DLP4710	FQL (100)	24.50-mm × 11-mm

(1) For all available packages, see the orderable addendum at the end of the data sheet.

#### DLP® DLP4710 0.47 1080p Chipset

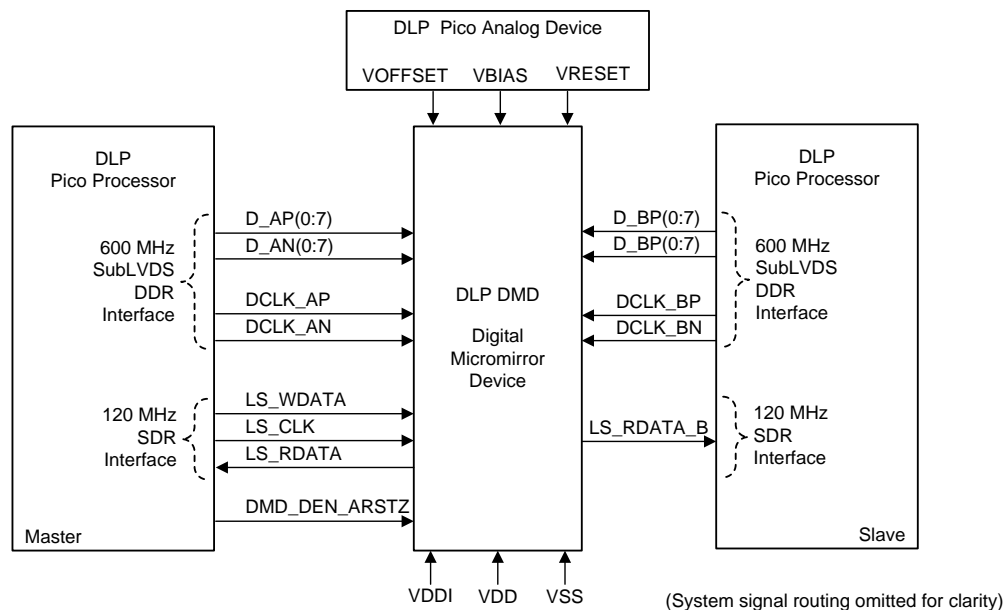

## Table of Contents

<b>1 Features</b> .....	1	7.4 Device Functional Modes.....	24
<b>2 Applications</b> .....	1	7.5 Optical Interface and System Image Quality Considerations .....	24
<b>3 Description</b> .....	1	7.6 Micromirror Array Temperature Calculation.....	25
<b>4 Revision History</b> .....	2	7.7 Micromirror Landed-On/Landed-Off Duty Cycle ....	26
<b>5 Pin Configuration and Functions</b> .....	3	<b>8 Application and Implementation</b> .....	29
<b>6 Specifications</b> .....	8	8.1 Application Information.....	29
6.1 Absolute Maximum Ratings .....	8	8.2 Typical Application .....	29
6.2 Storage Conditions.....	9	<b>9 Power Supply Recommendations</b> .....	32
6.3 ESD Ratings.....	9	9.1 Power Supply Power-Up Procedure .....	32
6.4 Recommended Operating Conditions.....	9	9.2 Power Supply Power-Down Procedure .....	32
6.5 Thermal Information .....	12	9.3 Power Supply Sequencing Requirements .....	33
6.6 Electrical Characteristics.....	12	<b>10 Layout</b> .....	35
6.7 Timing Requirements.....	13	10.1 Layout Guidelines .....	35
6.8 Switching Characteristics .....	18	10.2 Layout Example .....	35
6.9 System Mounting Interface Loads .....	19	<b>11 Device and Documentation Support</b> .....	36
6.10 Physical Characteristics of the Micromirror Array ..	20	11.1 Device Support.....	36
6.11 Micromirror Array Optical Characteristics .....	21	11.2 Related Links .....	36
6.12 Window Characteristics.....	22	11.3 Community Resources.....	36
6.13 Chipset Component Usage Specification .....	22	11.4 Trademarks .....	37
6.14 Software Requirements.....	22	11.5 Electrostatic Discharge Caution.....	37
<b>7 Detailed Description</b> .....	23	11.6 Glossary .....	37
7.1 Overview .....	23	<b>12 Mechanical, Packaging, and Orderable Information</b> .....	37
7.2 Functional Block Diagram .....	23		
7.3 Feature Description.....	24		

## 4 Revision History

DATE	REVISION	NOTES
November 2018	*	Initial release.

## 5 Pin Configuration and Functions

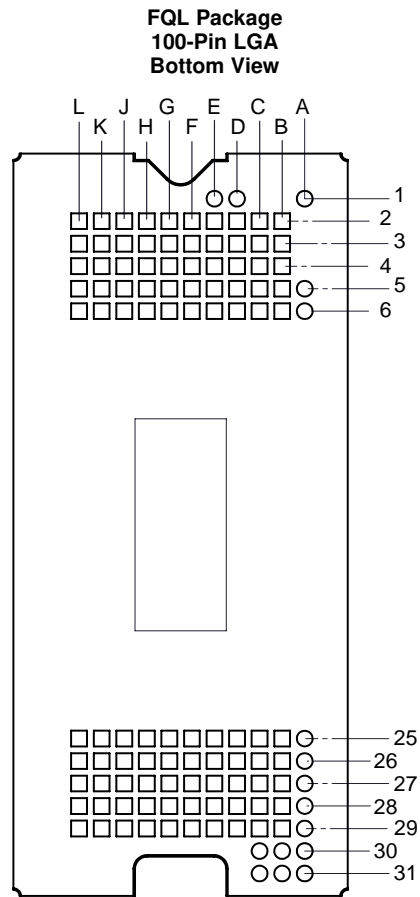

**Pin Functions – Connector Pins<sup>(1)</sup>**

PIN		TYPE	SIGNAL	DATA RATE	DESCRIPTION	PACKAGE NET LENGTH <sup>(2)</sup> (mm)
NAME	NO.					
<b>DATA INPUTS</b>						
D_AN(0)	G3	I	SubLVDS	Double	Data, Negative	5.01
D_AN(1)	F4	I	SubLVDS	Double	Data, Negative	2.03
D_AN(2)	E3	I	SubLVDS	Double	Data, Negative	2.41
D_AN(3)	E6	I	SubLVDS	Double	Data, Negative	4.71
D_AN(4)	J5	I	SubLVDS	Double	Data, Negative	3.23
D_AN(5)	L5	I	SubLVDS	Double	Data, Negative	3.87
D_AN(6)	G5	I	SubLVDS	Double	Data, Negative	6.32
D_AN(7)	L3	I	SubLVDS	Double	Data, Negative	1.84
D_AP(0)	H3	I	SubLVDS	Double	Data, Positive	5.01
D_AP(1)	G4	I	SubLVDS	Double	Data, Positive	2.03
D_AP(2)	E4	I	SubLVDS	Double	Data, Positive	2.41
D_AP(3)	E5	I	SubLVDS	Double	Data, Positive	4.71

(1) Low speed interface is LPSDR and adheres to the Electrical Characteristics and AC/DC Operating Conditions table in JEDEC Standard No. 209B, *Low Power Double Data Rate (LPDDR) JESD209B*.

(2) Net trace lengths inside the package:  
 Relative dielectric constant for the FQL ceramic package is 9.8.  
 Propagation speed =  $11.8 / \sqrt{9.8} = 3.769$  inches/ns.  
 Propagation delay =  $0.265$  ns/inch =  $265$  ps/inch =  $10.43$  ps/mm.

**Pin Functions – Connector Pins<sup>(1)</sup> (continued)**

PIN		TYPE	SIGNAL	DATA RATE	DESCRIPTION	PACKAGE NET LENGTH <sup>(2)</sup> (mm)
NAME	NO.					
D_AP(4)	J6	I	SubLVDS	Double	Data, Positive	3.23
D_AP(5)	L6	I	SubLVDS	Double	Data, Positive	3.87
D_AP(6)	G6	I	SubLVDS	Double	Data, Positive	6.32
D_AP(7)	L4	I	SubLVDS	Double	Data, Positive	1.84
D_BN(0)	G27	I	SubLVDS	Double	Data, Negative	2.51
D_BN(1)	E26	I	SubLVDS	Double	Data, Negative	4.43
D_BN(2)	D28	I	SubLVDS	Double	Data, Negative	2.76
D_BN(3)	D26	I	SubLVDS	Double	Data, Negative	5.47
D_BN(4)	L25	I	SubLVDS	Double	Data, Negative	4.85
D_BN(5)	K25	I	SubLVDS	Double	Data, Negative	4.10
D_BN(6)	L28	I	SubLVDS	Double	Data, Negative	2.53
D_BN(7)	K27	I	SubLVDS	Double	Data, Negative	2.76
D_BP(0)	F27	I	SubLVDS	Double	Data, Positive	2.51
D_BP(1)	E27	I	SubLVDS	Double	Data, Positive	4.43
D_BP(2)	D27	I	SubLVDS	Double	Data, Positive	2.76
D_BP(3)	D25	I	SubLVDS	Double	Data, Positive	5.47
D_BP(4)	L26	I	SubLVDS	Double	Data, Positive	4.85
D_BP(5)	J25	I	SubLVDS	Double	Data, Positive	4.10
D_BP(6)	K28	I	SubLVDS	Double	Data, Positive	2.53
D_BP(7)	J27	I	SubLVDS	Double	Data, Positive	2.76
DCLK_AN	J3	I	SubLVDS	Double	Clock, Negative	3.77
DCLK_AP	K3	I	SubLVDS	Double	Clock, Positive	3.77
DCLK_BN	H26	I	SubLVDS	Double	Clock, Negative	2.98
DCLK_BP	H27	I	SubLVDS	Double	Clock, Positive	2.98
<b>CONTROL INPUTS</b>						
LS_WDATA	D3	I	LPSDR <sup>(1)</sup>	Single	Write data for low speed interface.	1.20
LS_CLK	C3	I	LPSDR	Single	Clock for low-speed interface	1.20
DMD_DEN_ARSTZ	B6	I	LPSDR		Asynchronous reset DMD signal. A low signal places the DMD in reset. A high signal releases the DMD from reset and places it in active mode.	4.19
LS_RDATA_A	C6	O	LPSDR	Single	Read data for low-speed interface	3.93
LS_RDATA_B	C4	O	LPSDR	Single	Read data for low-speed interface	2.57
<b>POWER</b>						
VBIAS <sup>(3)</sup>	B27	Power			Supply voltage for positive bias level at micromirrors	24.51
VBIAS <sup>(3)</sup>	B4	Power				24.51
VOFFSET <sup>(3)</sup>	B2	Power			Supply voltage for HVCMOS core logic. Supply voltage for stepped high level at micromirror address electrodes. Supply voltage for offset level at micromirrors.	49.56
VOFFSET <sup>(3)</sup>	C29	Power				49.56
VRESET	B28	Power			Supply voltage for negative reset level at micromirrors.	24.82
VRESET	B3	Power				24.82

(3) The following power supplies are all required to operate the DMD: VDD, VDDI, VOFFSET, VBIAS, VRESET. All VSS connections are also required.

**Pin Functions – Connector Pins<sup>(1)</sup> (continued)**

PIN		TYPE	SIGNAL	DATA RATE	DESCRIPTION	PACKAGE NET LENGTH <sup>(2)</sup> (mm)
NAME	NO.					
VDD <sup>(3)</sup>	C2	Power			Supply voltage for LVC MOS core logic. Supply voltage for LPSDR inputs. Supply voltage for normal high level at micromirror address electrodes.	
VDD	D2	Power				
VDD	D29	Power				
VDD	E2	Power				
VDD	E29	Power				
VDD	H2	Power				
VDD	H28	Power				
VDD	H29	Power				
VDD	J2	Power				
VDD	J28	Power				
VDD	J29	Power				
VDD	K2	Power				
VDD	K29	Power				
VDD	L2	Power				
VDD	L29	Power				
VDDI	E28	Power				Supply voltage for SubLVDS receivers.
VDDI	F2	Power				
VDDI	F28	Power				
VDDI	F29	Power				
VDDI	F3	Power				
VDDI	G2	Power				
VDDI	G28	Power				
VDDI	G29	Power				

**Pin Functions – Connector Pins<sup>(1)</sup> (continued)**

PIN		TYPE	SIGNAL	DATA RATE	DESCRIPTION	PACKAGE NET LENGTH <sup>(2)</sup> (mm)
NAME	NO.					
VSS	B25	Ground			Common return. Ground for all power.	
VSS	B26	Ground				
VSS	B29	Ground				
VSS	B5	Ground				
VSS	C25	Ground				
VSS	C26	Ground				
VSS	C27	Ground				
VSS	C28	Ground				
VSS	C5	Ground				
VSS	D4	Ground				
VSS	D5	Ground				
VSS	D6	Ground				
VSS	E25	Ground				
VSS	F25	Ground				
VSS	F26	Ground				
VSS	F5	Ground				
VSS	F6	Ground				
VSS	G25	Ground				
VSS	G26	Ground				
VSS	H25	Ground				
VSS	H4	Ground				
VSS	H5	Ground				
VSS	H6	Ground				
VSS	J26	Ground				
VSS	J4	Ground				
VSS	K26	Ground				
VSS	K4	Ground				
VSS	K5	Ground				
VSS	K6	Ground				
VSS	L27	Ground				

**Pin Functions – Test Pads**

<b>NUMBER</b>	<b>SYSTEM BOARD</b>
A1	Do not connect
A5	Do not connect
A6	Do not connect
A25	Do not connect
A26	Do not connect
A27	Do not connect
A28	Do not connect
A29	Do not connect
A30	Do not connect
A31	Do not connect
B30	Do not connect
B31	Do not connect
C30	Do not connect
C31	Do not connect
D1	Do not connect
E1	Do not connect

## 6 Specifications

### 6.1 Absolute Maximum Ratings

see <sup>(1)</sup>

			MIN	MAX	UNIT
Supply voltage	VDD	Supply voltage for LVCMOS core logic <sup>(2)</sup> Supply voltage for LPSDR low speed interface	-0.5	2.3	V
	VDDI	Supply voltage for SubLVDS receivers <sup>(2)</sup>	-0.5	2.3	V
	VOFFSET	Supply voltage for HVCMOS and micromirror electrode <sup>(2) (3)</sup>	-0.5	11	V
	VBIAS	Supply voltage for micromirror electrode <sup>(2)</sup>	-0.5	19	V
	VRESET	Supply voltage for micromirror electrode <sup>(2)</sup>	-15	0.5	V
	VDDI-VDD	Supply voltage delta (absolute value) <sup>(4)</sup>		0.3	V
	VBIAS-VOFFSET	Supply voltage delta (absolute value) <sup>(5)</sup>		11	V
Input voltage	Input voltage for other inputs LPSDR <sup>(2)</sup>		-0.5	VDD + 0.5	V
	Input voltage for other inputs SubLVDS <sup>(2) (7)</sup>		-0.5	VDDI + 0.5	V
Input pins	VID	SubLVDS input differential voltage (absolute value) <sup>(7)</sup>		810	mV
	IID	SubLVDS input differential current		10	mA
Clock frequency	f <sub>clock</sub>	Clock frequency for low speed interface LS_CLK		130	MHz
	f <sub>clock</sub>	Clock frequency for high speed interface DCLK		620	MHz
Environmental	T <sub>ARRAY</sub> and T <sub>WINDOW</sub>	Temperature – operational <sup>(8)</sup>	-20	90	°C
		Temperature – non-operational <sup>(8)</sup>	-40	90	°C
	T <sub>DP</sub>	Dew Point Temperature - operating and non-operating (non-condensing)		81	°C
	T <sub>DELTA</sub>	Absolute Temperature delta between any point on the window edge and the ceramic test point TP1 <sup>(9)</sup>		30	°C

- (1) Stresses beyond those listed under *Absolute Maximum Ratings* may cause permanent damage to the device. These are stress ratings only, and functional operation of the device is not implied at these or any other conditions beyond those indicated under *Recommended Operating Conditions*. Exposure above or below the *Recommended Operating Conditions* for extended periods may affect device reliability.
- (2) All voltage values are with respect to the ground terminals (VSS). The following power supplies are all required to operate the DMD: VDD, VDDI, VOFFSET, VBIAS, and VRESET. All VSS connections are also required.
- (3) VOFFSET supply transients must fall within specified voltages.
- (4) Exceeding the recommended allowable absolute voltage difference between VDDI and VDD may result in excessive current draw.
- (5) Exceeding the recommended allowable absolute voltage difference between VBIAS and VOFFSET may result in excessive current draw.
- (6) Exceeding the recommended allowable absolute voltage difference between VBIAS and VRESET may result in excessive current draw.
- (7) This maximum input voltage rating applies when each input of a differential pair is at the same voltage potential. Sub-LVDS differential inputs must not exceed the specified limit or damage may result to the internal termination resistors.
- (8) The highest temperature of the active array (as calculated by the *Micromirror Array Temperature Calculation*) or of any point along the Window Edge as defined in *Figure 18*. The locations of thermal test points TP2, TP3, TP4, and TP5 in *Figure 18* are intended to measure the highest window edge temperature. If a particular application causes another point on the window edge to be at a higher temperature, that point should be used.
- (9) Temperature delta is the highest difference between the ceramic test point 1 (TP1) and anywhere on the window edge as shown in *Figure 18*. The window test points TP2, TP3, TP4, and TP5 shown in *Figure 18* are intended to result in the worst case delta. If a particular application causes another point on the window edge to result in a larger delta temperature, that point should be used.



## 6.2 Storage Conditions

applicable for the DMD as a component or non-operational in a system

		MIN	MAX	UNIT
$T_{DMD}$	DMD storage temperature	-40	85	°C
$T_{DP-AVG}$	Average dew point temperature, (non-condensing) <sup>(1)</sup>		24	°C
$T_{DP-ELR}$	Elevated dew point temperature range, (non-condensing) <sup>(2)</sup>	28	36	°C
$CT_{ELR}$	Cumulative time in elevated dew point temperature range		6	Months

- (1) The average over time (including storage and operating) that the device is not in the elevated dew point temperature range.  
(2) Exposure to dew point temperatures in the elevated range during storage and operation should be limited to less than a total cumulative time of  $CT_{ELR}$ .

## 6.3 ESD Ratings

		VALUE	UNIT
$V_{(ESD)}$	Electrostatic discharge Human body model (HBM), per ANSI/ESDA/JEDEC JS-001 <sup>(1)</sup>	±2000	V

- (1) JEDEC document JEP155 states that 500 V HBM allows safe manufacturing with a standard ESD control process.

## 6.4 Recommended Operating Conditions

Over operating free-air temperature range (unless otherwise noted)<sup>(1)</sup> <sup>(2)</sup> <sup>(3)</sup>

		MIN	NOM	MAX	UNIT
<b>SUPPLY VOLTAGE RANGE<sup>(4)</sup></b>					
$V_{DD}$	Supply voltage for LVCMOS core logic Supply voltage for LPSDR low-speed interface	1.7	1.8	1.95	V
$V_{DDI}$	Supply voltage for SubLVDS receivers	1.7	1.8	1.95	V
$V_{OFFSET}$	Supply voltage for HVCMOS and micromirror electrode <sup>(5)</sup>	9.5	10	10.5	V
$V_{BIAS}$	Supply voltage for mirror electrode	17.5	18	18.5	V
$V_{RESET}$	Supply voltage for micromirror electrode	-14.5	-14	-13.5	V
$ V_{DDI}-V_{DD} $	Supply voltage delta (absolute value) <sup>(6)</sup>			0.3	V
$ V_{BIAS}-V_{OFFSET} $	Supply voltage delta (absolute value) <sup>(7)</sup>			10.5	V
$ V_{BIAS}-V_{RESET} $	Supply voltage delta (absolute value) <sup>(8)</sup>			33	V
<b>CLOCK FREQUENCY</b>					
$f_{clock}$	Clock frequency for low speed interface LS_CLK <sup>(9)</sup>	108		120	MHz
$f_{clock}$	Clock frequency for high speed interface DCLK <sup>(10)</sup>	300		540	MHz
	Duty cycle distortion DCLK	44%		56%	
<b>SUBLVDS INTERFACE<sup>(10)</sup></b>					
$ V_{ID} $	SubLVDS input differential voltage (absolute value) <a href="#">Figure 8</a> , <a href="#">Figure 9</a>	150	250	350	mV
$V_{CM}$	Common mode voltage <a href="#">Figure 8</a> , <a href="#">Figure 9</a>	700	900	1100	mV
$V_{SUBLVDS}$	SubLVDS voltage <a href="#">Figure 8</a> , <a href="#">Figure 9</a>	575		1225	mV
$Z_{LINE}$	Line differential impedance (PWB/trace)	90	100	110	Ω
$Z_{IN}$	Internal differential termination resistance <a href="#">Figure 10</a>	80	100	120	Ω
	100-Ω differential PCB trace	6.35		152.4	mm

- (1) The following power supplies are all required to operate the DMD: VDD, VDDI, VOFFSET, VBIAS, and VRESET. All VSS connections are also required.  
(2) [Recommended Operating Conditions](#) are applicable after the DMD is installed in the final product.  
(3) The functional performance of the device specified in this data sheet is achieved when operating the device within the limits defined by the [Recommended Operating Conditions](#). No level of performance is implied when operating the device above or below the [Recommended Operating Conditions](#) limits.  
(4) All voltage values are with respect to the ground pins (VSS).  
(5) VOFFSET supply transients must fall within specified max voltages.  
(6) To prevent excess current, the supply voltage delta  $|V_{DDI} - V_{DD}|$  must be less than specified limit.  
(7) To prevent excess current, the supply voltage delta  $|V_{BIAS} - V_{OFFSET}|$  must be less than specified limit.  
(8) To prevent excess current, the supply voltage delta  $|V_{BIAS} - V_{RESET}|$  must be less than specified limit.  
(9) LS\_CLK must run as specified to ensure internal DMD timing for reset waveform commands.  
(10) Refer to the SubLVDS timing requirements in .

## Recommended Operating Conditions (continued)

Over operating free-air temperature range (unless otherwise noted)<sup>(1) (2) (3)</sup>

		MIN	NOM	MAX	UNIT
<b>ENVIRONMENTAL</b>					
T <sub>ARRAY</sub>	Array Temperature – long-term operational <sup>(11)(12)(13)(14)</sup>	0		40 to 70 <sup>(13)</sup>	°C
	Array Temperature - short-term operational, 25 hr max <sup>(12)(15)</sup>	-20		-10	
	Array Temperature - short-term operational, 500 hr max <sup>(12)(15)</sup>	-10		0	
	Array Temperature – short-term operational, 500 hr max <sup>(12)(15)</sup>	70		75	
T <sub>DELTA</sub>	Absolute Temperature difference between any point on the window edge and the ceramic test point TP1 <sup>(16)</sup>			30	°C
T <sub>WINDOW</sub>	Window Temperature – operational <sup>(11) (17)</sup>			90	°C
T <sub>DP-AVG</sub>	Average dew point temperature (non-condensing) <sup>(18)</sup>			24	°C
T <sub>DP-ELR</sub>	Elevated dew point temperature range (non-condensing) <sup>(19)</sup>	28		36	°C
CT <sub>ELR</sub>	Cumulative time in elevated dew point temperature range			6	Months
ILL <sub>UV</sub>	Illumination wavelengths < 420 nm <sup>(11)</sup>			0.68	mW/cm <sup>2</sup>
ILL <sub>VIS</sub>	Illumination wavelengths between 420 nm and 700 nm			Thermally limited	
ILL <sub>IR</sub>	Illumination wavelengths > 700 nm			10	mW/cm <sup>2</sup>
ILL <sub>θ</sub>	Illumination marginal ray angle <sup>(20)</sup>			55	degrees

- (11) Simultaneous exposure of the DMD to the maximum *Recommended Operating Conditions* for temperature and UV illumination will reduce device lifetime.
- (12) The array temperature cannot be measured directly and must be computed analytically from the temperature measured at test point 1 (TP1) shown in [Figure 18](#) and the Package Thermal Resistance using *Micromirror Array Temperature Calculation*.
- (13) Per [Figure 1](#), the maximum operational array temperature should be derated based on the micromirror landed duty cycle that the DMD experiences in the end application. Refer to *Micromirror Landed-On/Landed-Off Duty Cycle* for a definition of micromirror landed duty cycle.
- (14) Long-term is defined as the usable life of the device
- (15) Short-term is the total cumulative time over the useful life of the device.
- (16) Temperature delta is the highest difference between the ceramic test point 1 (TP1) and anywhere on the window edge shown in [Figure 18](#). The window test points TP2, TP3, TP4, and TP5 shown in [Figure 18](#) are intended to result in the worst case delta temperature. If a particular application causes another point on the window edge to result in a larger delta temperature, that point should be used.
- (17) Window temperature is the highest temperature on the window edge shown in [Figure 18](#). The locations of thermal test points TP2, TP3, TP4, and TP5 in [Figure 18](#) are intended to measure the highest window edge temperature. If a particular application causes another point on the window edge to be at a higher temperature, that point should be used.
- (18) The average over time (including storage and operating) that the device is not in the elevated dew point temperature range.
- (19) Exposure to dew point temperatures in the elevated range during storage and operation should be limited to less than a total cumulative time of CT<sub>ELR</sub>.
- (20) The maximum marginal ray angle of the incoming illumination light at any point in the micromirror array, including Pond of Micromirrors (POM), should not exceed 55 degrees from the normal to the device array plane. The device window aperture has not necessarily been designed to allow incoming light at higher maximum angles to pass to the micromirrors, and the device performance has not been tested nor qualified at angles exceeding this. Illumination light exceeding this angle outside the micromirror array (including POM) will contribute to thermal limitations described in this document, and may negatively affect lifetime.

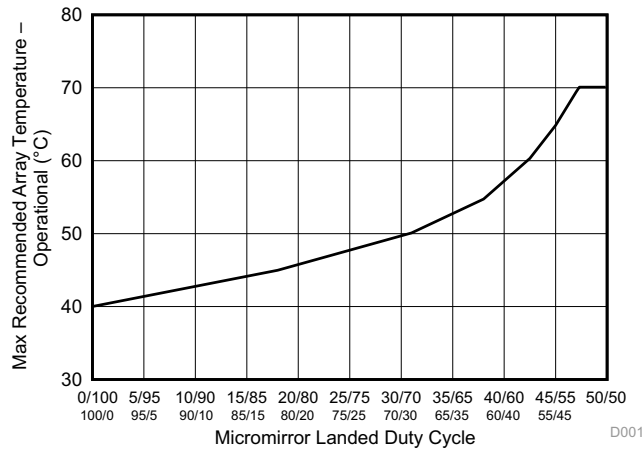

**Figure 1. Max Recommended Array Temperature – Derating Curve**

## 6.5 Thermal Information

THERMAL METRIC <sup>(1)</sup>		DLP4710	
		FQL (LGA)	UNIT
		100 PINS	
Thermal resistance	Active area to test point 1 (TP1) <sup>(1)</sup>	1.1	°C/W

- (1) The DMD is designed to conduct absorbed and dissipated heat to the back of the package. The cooling system must be capable of maintaining the package within the temperature range specified in the [Recommended Operating Conditions](#). The total heat load on the DMD is largely driven by the incident light absorbed by the active area; although other contributions include light energy absorbed by the window aperture and electrical power dissipation of the array. Optical systems should be designed to minimize the light energy falling outside the window clear aperture since any additional thermal load in this area can significantly degrade the reliability of the device.

## 6.6 Electrical Characteristics

Over operating free-air temperature range (unless otherwise noted)<sup>(1)</sup>

PARAMETER		TEST CONDITIONS <sup>(2)</sup>	MIN	TYP	MAX	UNIT
<b>CURRENT</b>						
I <sub>DD</sub>	Supply current: VDD <sup>(3)</sup> (4)	V <sub>DD</sub> = 1.95 V			260	mA
		V <sub>DD</sub> = 1.8 V		180		
I <sub>DDI</sub>	Supply current: VDDI <sup>(3)</sup> (4)	V <sub>DDI</sub> = 1.95 V			62	mA
		V <sub>DDI</sub> = 1.8 V		40		
I <sub>OFFSET</sub>	Supply current: V <sub>OFFSET</sub> <sup>(5)</sup> (6)	V <sub>OFFSET</sub> = 10.5 V			7.4	mA
		V <sub>OFFSET</sub> = 10 V		6.3		
I <sub>BIAS</sub>	Supply current: V <sub>BIAS</sub> <sup>(5)</sup> (6)	V <sub>BIAS</sub> = 18.5 V			1.1	mA
		V <sub>BIAS</sub> = 18 V		0.9		
I <sub>RESET</sub>	Supply current: V <sub>RESET</sub> <sup>(6)</sup>	V <sub>RESET</sub> = -14.5 V			5.4	mA
		V <sub>RESET</sub> = -14 V		4.4		
<b>POWER<sup>(7)</sup></b>						
P <sub>DD</sub>	Supply power dissipation: VDD <sup>(3)</sup> (4)	VDD = 1.95 V			507	mW
		VDD = 1.8 V		324		
P <sub>DDI</sub>	Supply power dissipation: VDDI <sup>(3)</sup> (4)	VDDI = 1.95 V			120.9	mW
		VDD = 1.8 V		72		
P <sub>OFFSET</sub>	Supply power dissipation: V <sub>OFFSET</sub> <sup>(5)</sup> (6)	V <sub>OFFSET</sub> = 10.5 V			77.7	mW
		V <sub>OFFSET</sub> = 10 V		63		
P <sub>BIAS</sub>	Supply power dissipation: V <sub>BIAS</sub> <sup>(5)</sup> (6)	V <sub>BIAS</sub> = 18.5 V			20.35	mW
		V <sub>BIAS</sub> = 18 V		16.2		
P <sub>RESET</sub>	Supply power dissipation: V <sub>RESET</sub> <sup>(6)</sup>	V <sub>RESET</sub> = -14.5 V			78.3	mW
		V <sub>RESET</sub> = -14 V		61.6		
P <sub>TOTAL</sub>	Supply power dissipation: Total			536.8	804.25	mW
<b>LPSDR INPUT<sup>(8)</sup></b>						
V <sub>IH(DC)</sub>	DC input high voltage <sup>(9)</sup>		0.7 × VDD		VDD + 0.3	V
V <sub>IL(DC)</sub>	DC input low voltage <sup>(9)</sup>		-0.3		0.3 × VDD	V
V <sub>IH(AC)</sub>	AC input high voltage <sup>(9)</sup>		0.8 × VDD		VDD + 0.3	V
V <sub>IL(AC)</sub>	AC input low voltage <sup>(9)</sup>		-0.3		0.2 × VDD	V
ΔV <sub>T</sub>	Hysteresis ( V <sub>T+</sub> - V <sub>T-</sub> )	<a href="#">Figure 10</a>	0.1 × VDD		0.4 × VDD	V

- (1) Device electrical characteristics are over [Recommended Operating Conditions](#) unless otherwise noted.  
 (2) All voltage values are with respect to the ground pins (VSS).  
 (3) To prevent excess current, the supply voltage delta |VDDI - VDD| must be less than specified limit.  
 (4) Supply power dissipation based on non-compressed commands and data.  
 (5) To prevent excess current, the supply voltage delta |VBIAS - V<sub>OFFSET</sub>| must be less than specified limit.  
 (6) Supply power dissipation based on 3 global resets in 200 μs.  
 (7) The following power supplies are all required to operate the DMD: VDD, VDDI, V<sub>OFFSET</sub>, VBIAS, V<sub>RESET</sub>. All VSS connections are also required.  
 (8) LPSDR specifications are for pins LS\_CLK and LS\_WDATA.  
 (9) Low-speed interface is LPSDR and adheres to the Electrical Characteristics and AC/DC Operating Conditions table in JEDEC Standard No. 209B, *Low-Power Double Data Rate (LPDDR) JESD209B*.

## Electrical Characteristics (continued)

Over operating free-air temperature range (unless otherwise noted)<sup>(1)</sup>

PARAMETER		TEST CONDITIONS <sup>(2)</sup>	MIN	TYP	MAX	UNIT
I <sub>IL</sub>	Low-level input current	VDD = 1.95 V; V <sub>I</sub> = 0 V	-100			nA
I <sub>IH</sub>	High-level input current	VDD = 1.95 V; V <sub>I</sub> = 1.95 V			100	nA
<b>LPSDR OUTPUT<sup>(10)</sup></b>						
V <sub>OH</sub>	DC output high voltage	I <sub>OH</sub> = -2 mA	0.8 × VDD			V
V <sub>OL</sub>	DC output low voltage	I <sub>OL</sub> = 2 mA			0.2 × VDD	V
<b>CAPACITANCE</b>						
C <sub>IN</sub>	Input capacitance LPSDR	f = 1 MHz			10	pF
	Input capacitance SubLVDS	f = 1 MHz			20	pF
C <sub>OUT</sub>	Output capacitance	f = 1 MHz			10	pF
C <sub>RESET</sub>	Reset group capacitance	f = 1 MHz; (1080 × 240) micromirrors	400		450	pF

(10) LPSDR specification is for pin LS\_RDATA.

## 6.7 Timing Requirements

Device electrical characteristics are over *Recommended Operating Conditions* unless otherwise noted.

			MIN	NOM	MAX	UNIT
<b>LPSDR</b>						
t <sub>r</sub>	Rise slew rate <sup>(1)</sup>	(30% to 80%) × VDD, <a href="#">Figure 3</a>	1		3	V/ns
t <sub>f</sub>	Fall slew rate <sup>(1)</sup>	(70% to 20%) × VDD, <a href="#">Figure 3</a>	1		3	V/ns
t <sub>r</sub>	Rise slew rate <sup>(2)</sup>	(20% to 80%) × VDD, <a href="#">Figure 3</a>	0.25			V/ns
t <sub>f</sub>	Fall slew rate <sup>(2)</sup>	(80% to 20%) × VDD, <a href="#">Figure 3</a>	0.25			V/ns
t <sub>c</sub>	Cycle time LS_CLK,	<a href="#">Figure 2</a>	7.7	8.3		ns
t <sub>W(H)</sub>	Pulse duration LS_CLK high	50% to 50% reference points, <a href="#">Figure 2</a>	3.1			ns
t <sub>W(L)</sub>	Pulse duration LS_CLK low	50% to 50% reference points, <a href="#">Figure 2</a>	3.1			ns
t <sub>su</sub>	Setup time	LS_WDATA valid before LS_CLK ↑, <a href="#">Figure 2</a>	1.5			ns
t <sub>h</sub>	Hold time	LS_WDATA valid after LS_CLK ↑, <a href="#">Figure 2</a>	1.5			ns
t <sub>WINDOW</sub>	Window time <sup>(1) (3)</sup>	Setup time + Hold time, <a href="#">Figure 2</a>	3.0			ns
t <sub>DERATING</sub>	Window time derating <sup>(1) (3)</sup>	For each 0.25 V/ns reduction in slew rate below 1 V/ns, <a href="#">Figure 5</a>		0.35		ns
<b>SubLVDS</b>						
t <sub>r</sub>	Rise slew rate	20% to 80% reference points, <a href="#">Figure 4</a>	0.7	1		V/ns
t <sub>f</sub>	Fall slew rate	80% to 20% reference points, <a href="#">Figure 4</a>	0.7	1		V/ns
t <sub>c</sub>	Cycle time DCLK,	<a href="#">Figure 6</a>	1.79	1.85		ns
t <sub>W(H)</sub>	Pulse duration DCLK high	50% to 50% reference points, <a href="#">Figure 6</a>	0.79			ns
t <sub>W(L)</sub>	Pulse duration DCLK low	50% to 50% reference points, <a href="#">Figure 6</a>	0.79			ns
t <sub>su</sub>	Setup time	D(0:7) valid before DCLK ↑ or DCLK ↓, <a href="#">Figure 6</a>				
t <sub>h</sub>	Hold time	D(0:7) valid after DCLK ↑ or DCLK ↓, <a href="#">Figure 6</a>				

(1) Specification is for LS\_CLK and LS\_WDATA pins. Refer to LPSDR input rise slew rate and fall slew rate in [Figure 3](#).

(2) Specification is for DMD\_DEN\_ARSTZ pin. Refer to LPSDR input rise and fall slew rate in [Figure 3](#).

(3) Window time derating example: 0.5-V/ns slew rate increases the window time by 0.7 ns, from 3 to 3.7 ns.

### Timing Requirements (continued)

Device electrical characteristics are over *Recommended Operating Conditions* unless otherwise noted.

		MIN	NOM	MAX	UNIT
$t_{WINDOW}$	Window time	3.0			ns
$t_{LVDS-ENABLE+REFGEN}$	Power-up receiver <sup>(4)</sup>			2000	ns

(4) Specification is for SubLVDS receiver time only and does not take into account commanding and latency after commanding.

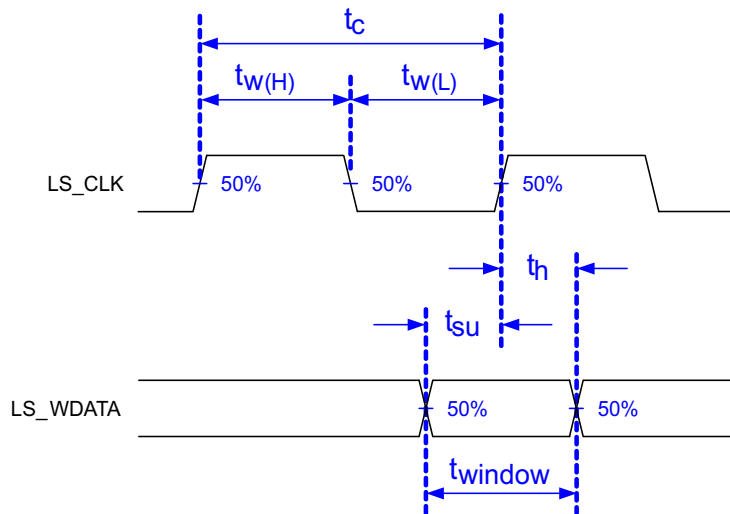

Low-speed interface is LPSDR and adheres to the *Electrical Characteristics* and AC/DC Operating Conditions table in JEDEC Standard No. 209B, *Low Power Double Data Rate (LPDDR) JESD209B*.

**Figure 2. LPSDR Switching Parameters**

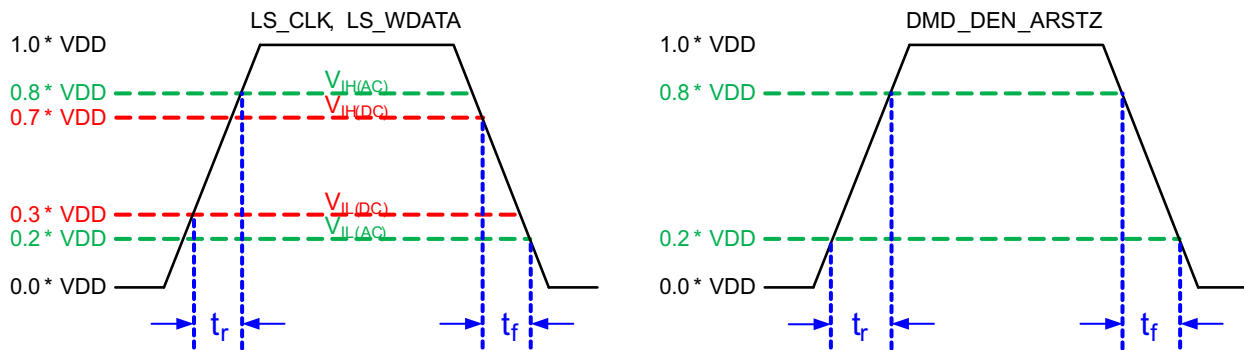

**Figure 3. LPSDR Input Rise and Fall Slew Rate**

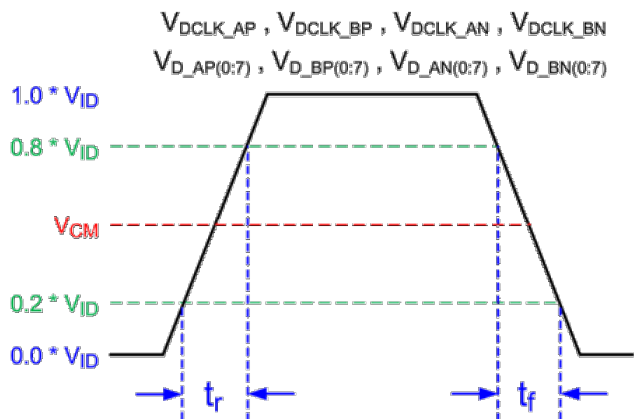

Figure 4. SubLVDS Input Rise and Fall Slew Rate

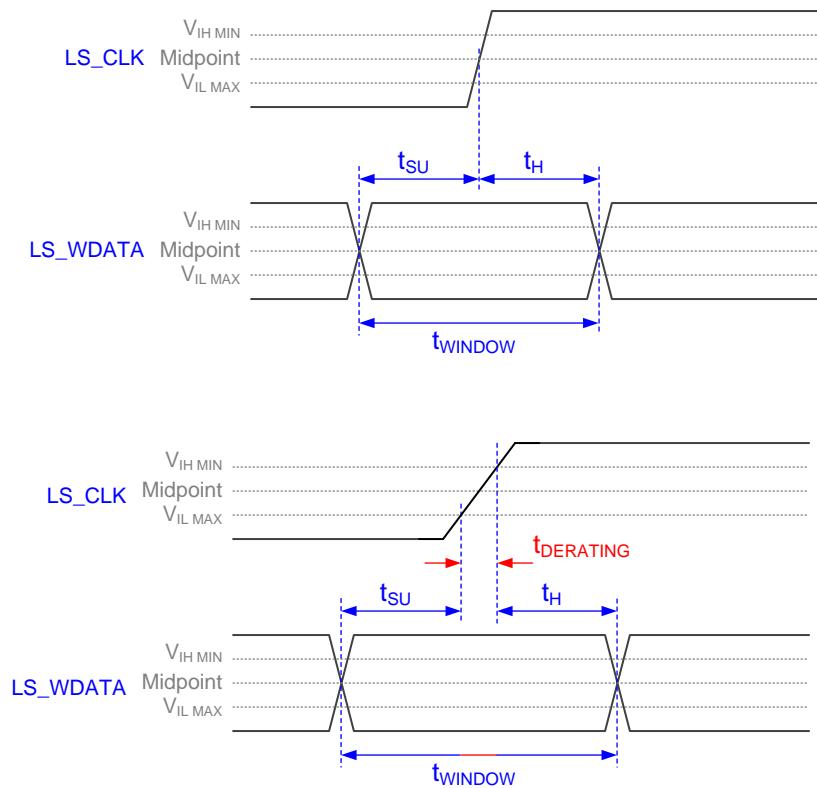

Figure 5. Window Time Derating Concept

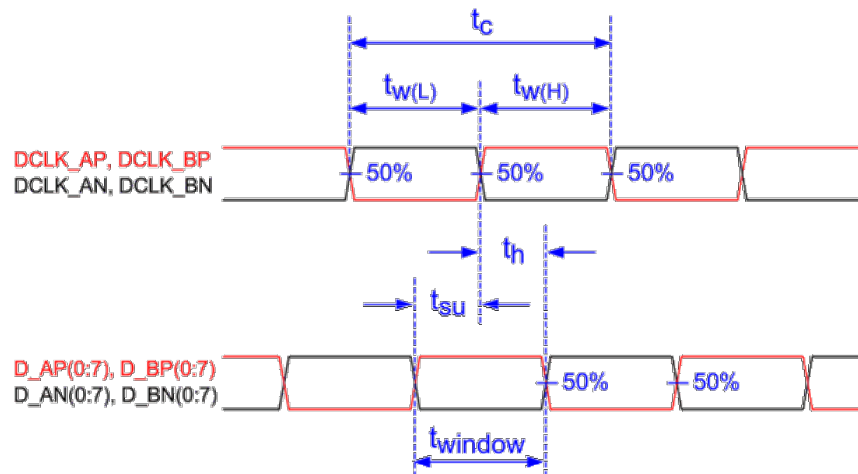
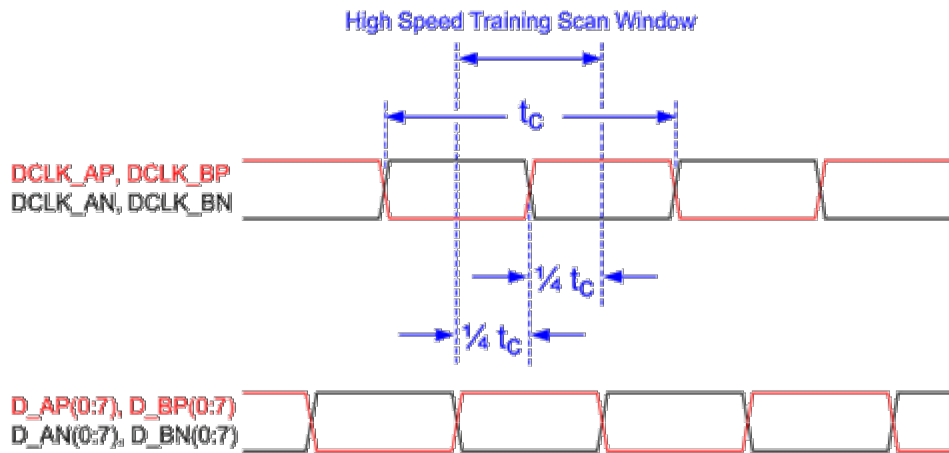

Figure 6. SubLVDS Switching Parameters



Note: Refer to [High-Speed Interface](#) for details.

Figure 7. High-Speed Training Scan Window



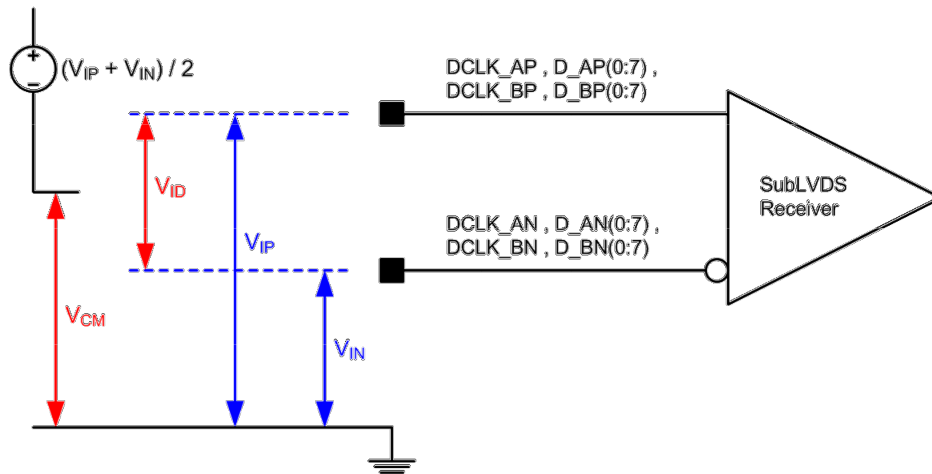

Figure 8. SubLVDS Voltage Parameters

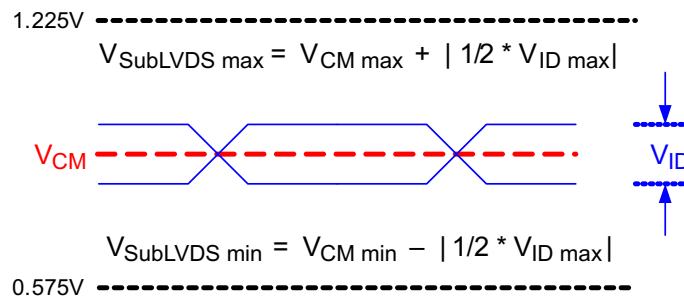

Figure 9. SubLVDS Waveform Parameters

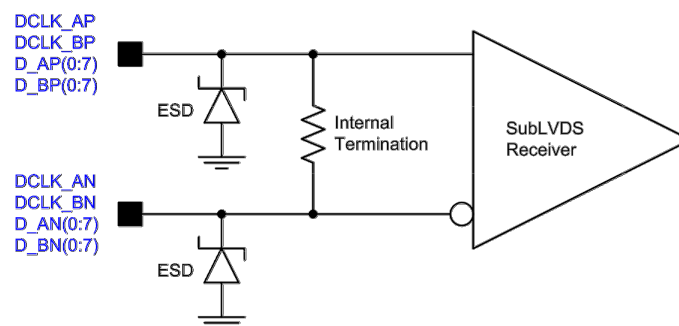

Figure 10. SubLVDS Equivalent Input Circuit

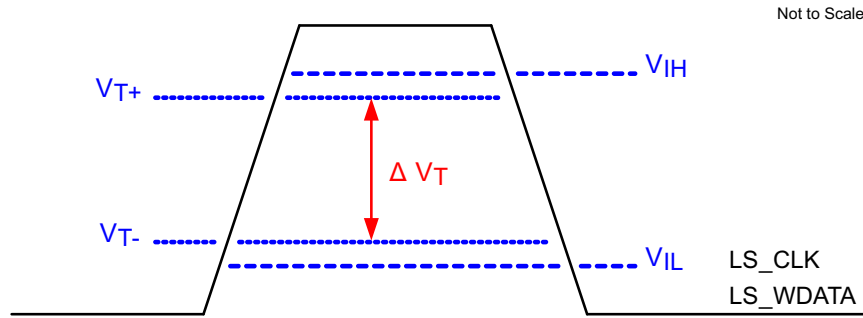

Figure 11. LPSDR Input Hysteresis

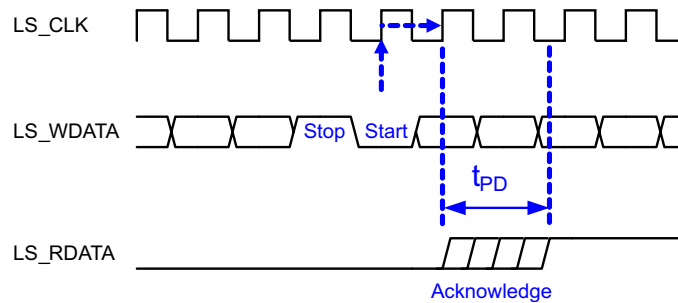
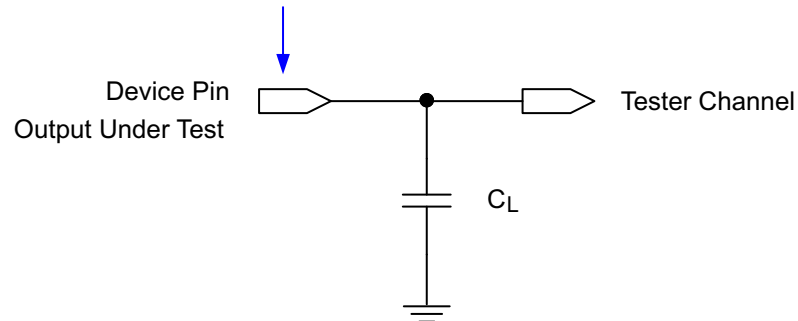

Figure 12. LPSDR Read Out

Data Sheet Timing Reference Point



See [Timing](#) for more information.

Figure 13. Test Load Circuit for Output Propagation Measurement

### 6.8 Switching Characteristics<sup>(1)</sup>

Over operating free-air temperature range (unless otherwise noted).

PARAMETER	TEST CONDITIONS	MIN	TYP	MAX	UNIT
$t_{PD}$	Output propagation, Clock to Q, rising edge of LS_CLK input to LS_RDATA output. <a href="#">Figure 12</a>			15	ns
	Slew rate, LS_RDATA	0.5			V/ns
	Output duty cycle distortion, LS_RDATA	40%		60%	

(1) Device electrical characteristics are over [Recommended Operating Conditions](#) unless otherwise noted.

### 6.9 System Mounting Interface Loads

	PARAMETER	MIN	NOM	MAX	UNIT
Maximum system mounting interface load to be applied to the:	Thermal interface area (see <a href="#">Figure 14</a> )			62	N1
	Clamping and electrical interface area (see <a href="#">Figure 14</a> )			110	N

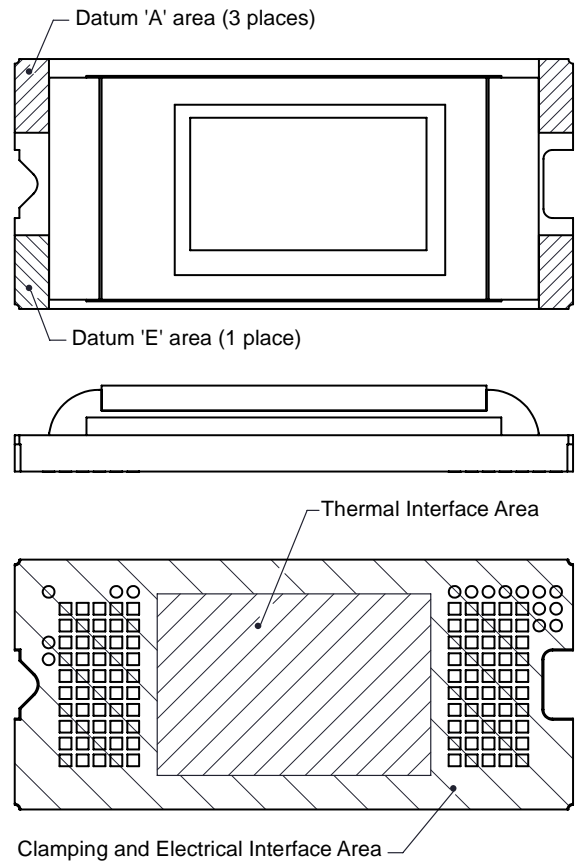

**Figure 14. System Interface Loads**

### 6.10 Physical Characteristics of the Micromirror Array

PARAMETER		VALUE	UNIT
Number of active columns	See <a href="#">Figure 15</a>	1920	micromirrors
Number of active rows	See <a href="#">Figure 15</a>	1080	micromirrors
$\epsilon$ Micromirror (pixel) pitch	See <a href="#">Figure 16</a>	5.4	$\mu\text{m}$
Micromirror active array width	Micromirror pitch $\times$ number of active columns; see <a href="#">Figure 15</a>	10.368	mm
Micromirror active array height	Micromirror pitch $\times$ number of active rows; see <a href="#">Figure 15</a>	5.832	mm
Micromirror active border	Pond of micromirror (POM) <sup>(1)</sup>	20	micromirrors/side

(1) The structure and qualities of the border around the active array includes a band of partially functional micromirrors called the POM. These micromirrors are structurally and/or electrically prevented from tilting toward the bright or ON state, but still require an electrical bias to tilt toward OFF.

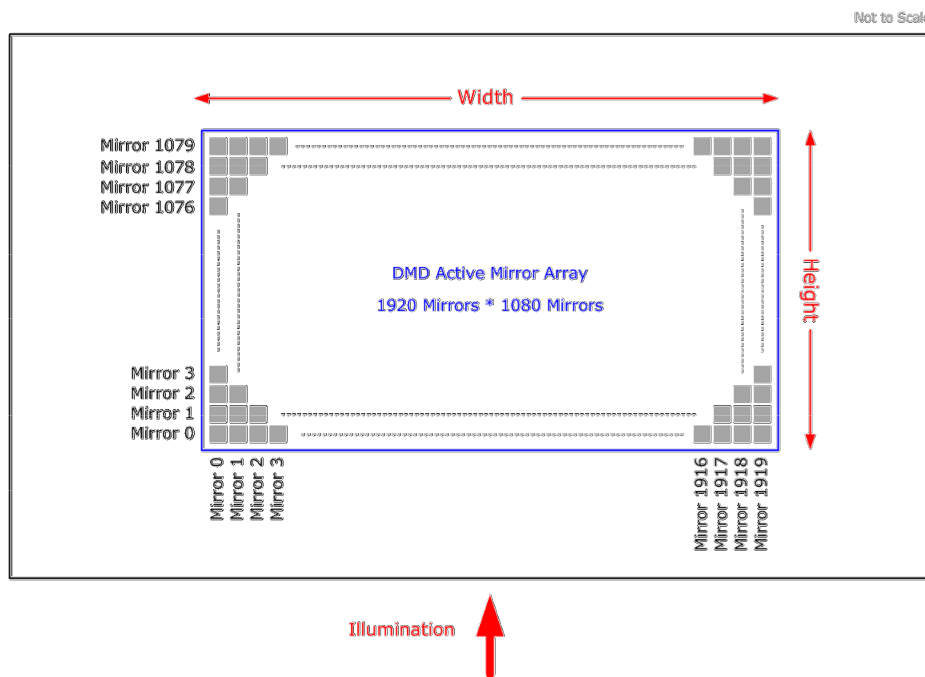

Figure 15. Micromirror Array Physical Characteristics

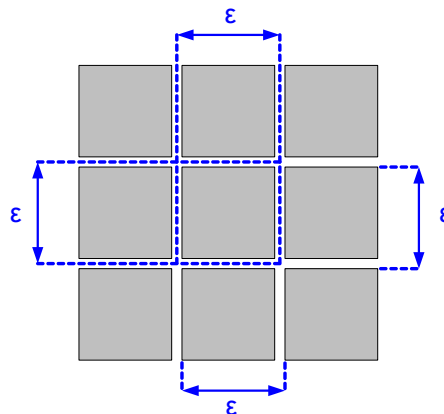
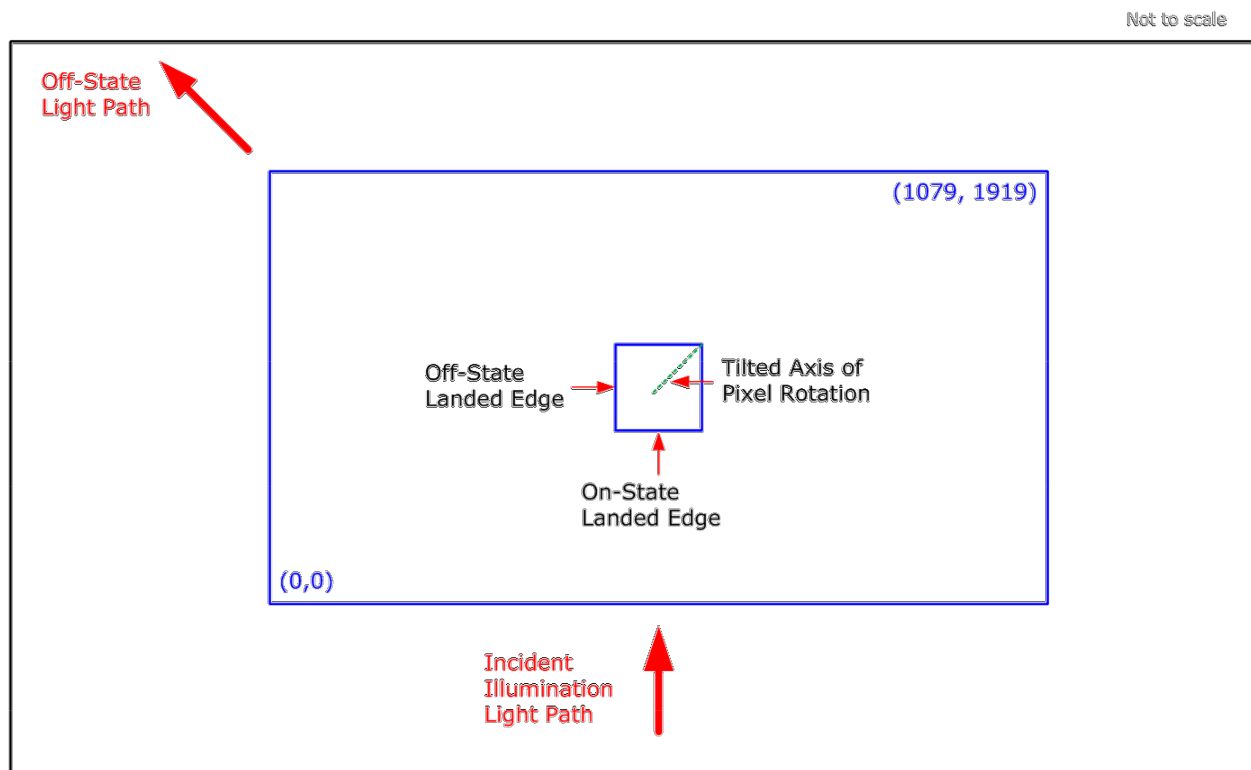

Figure 16. Mirror (Pixel) Pitch

### 6.11 Micromirror Array Optical Characteristics

PARAMETER	TEST CONDITIONS	MIN	NOM	MAX	UNIT
Micromirror tilt angle	DMD landed state <sup>(1)</sup>		17		degrees
Micromirror tilt angle tolerance <sup>(2) (3) (4) (5)</sup>		-1.4		1.4	degrees
Micromirror tilt direction <sup>(6) (7)</sup>	Landed OFF state		180		degrees
	Landed ON state		270		
Micromirror crossover time <sup>(8)</sup>	Typical Performance		1	3	µs
Micromirror switching time <sup>(9)</sup>	Typical Performance	10			
Number of out-of-specification micromirrors <sup>(10)</sup>	Adjacent micromirrors			0	micromirrors
	Non-adjacent micromirrors			10	

- (1) Measured relative to the plane formed by the overall micromirror array.
- (2) Additional variation exists between the micromirror array and the package datums.
- (3) Represents the landed tilt angle variation relative to the nominal landed tilt angle.
- (4) Represents the variation that can occur between any two individual micromirrors, located on the same device or located on different devices.
- (5) For some applications, it is critical to account for the micromirror tilt angle variation in the overall system optical design. With some system optical designs, the micromirror tilt angle variation within a device may result in perceivable non-uniformities in the light field reflected from the micromirror array. With some system optical designs, the micromirror tilt angle variation between devices may result in colorimetry variations, system efficiency variations or system contrast variations.
- (6) When the micromirror array is landed (not parked), the tilt direction of each individual micromirror is dictated by the binary contents of the CMOS memory cell associated with each individual micromirror. A binary value of 1 results in a micromirror landing in the ON State direction. A binary value of 0 results in a micromirror landing in the OFF State direction.
- (7) Micromirror tilt direction is measured as in a typical polar coordinate system: measuring counter-clockwise from a 0° reference which is aligned with the +X Cartesian axis.
- (8) The time required for a micromirror to nominally transition from one landed state to the opposite landed state.
- (9) The minimum time between successive transitions of a micromirror.
- (10) An out-of-specification micromirror is defined as a micromirror that is unable to transition between the two landed states within the specified Micromirror Switching Time.



**Figure 17. Landed Pixel Orientation and Tilt**

## 6.12 Window Characteristics

PARAMETER <sup>(1)</sup>		MIN	NOM	MAX	UNIT
Window material designation		Corning Eagle XG			
Window refractive index	at wavelength 546.1 nm	1.5119			
Window aperture <sup>(2)</sup>					See <sup>(2)</sup>
Illumination overfill <sup>(3)</sup>					See <sup>(3)</sup>
Window transmittance, single-pass through both surfaces and glass	Minimum within the wavelength range 420 to 680 nm. Applies to all angles 0° to 30° AOI.	97%			
Window Transmittance, single-pass through both surfaces and glass	Average over the wavelength range 420 to 680 nm. Applies to all angles 30° to 45° AOI.	97%			

(1) See [Optical Interface and System Image Quality Considerations](#) for more information.

(2) See the package mechanical characteristics for details regarding the size and location of the window aperture.

(3) The active area of the DLP4710 device is surrounded by an aperture on the inside of the DMD window surface that masks structures of the DMD device assembly from normal view. The aperture is sized to anticipate several optical conditions. Overfill light illuminating the area outside the active array can scatter and create adverse effects to the performance of an end application using the DMD. The illumination optical system should be designed to limit light flux incident outside the active array to less than 10% of the average flux level in the active area. Depending on the particular system's optical architecture and assembly tolerances, the amount of overfill light on the outside of the active array may cause system performance degradation.

## 6.13 Chipset Component Usage Specification

The DLP4710 device is a component of one or more DLP chipsets. Reliable function and operation of the device requires that it be used in conjunction with the other components of the applicable DLP chipset, including those components that contain or implement TI DMD control technology. TI DMD control technology is the TI technology and devices for operating or controlling a DLP DMD.

### NOTE

TI assumes no responsibility for image quality artifacts or DMD failures caused by optical system operating conditions exceeding limits described previously

## 6.14 Software Requirements

### CAUTION

The DLP4710 DMD has mandatory software requirements. Refer to [Software Requirements for TI DLP® Pico™ TRP Digital Micromirror Devices](#) application report for additional information. Failure to use the specified software will result in failure at power up.

## 7 Detailed Description

### 7.1 Overview

The DLP4710 device is a 0.47 inch diagonal spatial light modulator of aluminum micromirrors. Pixel array size is 1920 columns by 1080 rows in a square grid pixel arrangement. The electrical interface is Sub Low Voltage Differential Signaling (SubLVDS) data.

DLP4710 device is part of the chipset comprising the DLP4710 DMD, DLPC3439 or DLPC3479 controller, and DLPA3000 or DLPA3005 PMIC/LED driver. To ensure reliable operation, the DLP4710 DMD must always be used with either the DLPC3439 or DLPC3479 controller and the DLPA3000 or DLPA3005 PMIC/LED drivers.

### 7.2 Functional Block Diagram

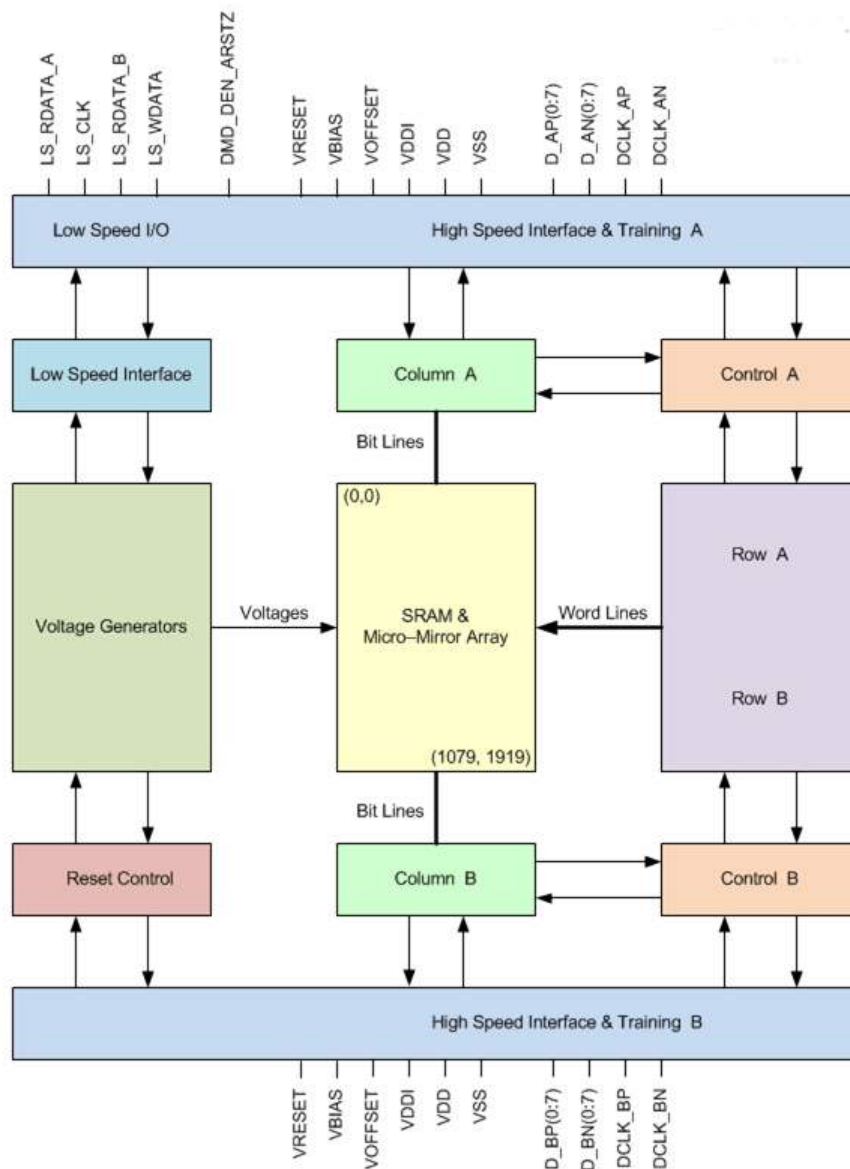

Simplified for clarity.

## 7.3 Feature Description

### 7.3.1 Power Interface

The power management IC, DLPA3000/DLPA3005, contains three regulated DC supplies for the DMD reset circuitry: VBIAS, VRESET and VOFFSET, as well as the 2 regulated DC supplies for the DLPC3439 or DLPC3479 controller.

### 7.3.2 Low-Speed Interface

The Low Speed Interface handles instructions that configure the DMD and control reset operation. LS\_CLK is the low-speed clock, and LS\_WDATA is the low speed data input.

### 7.3.3 High-Speed Interface

The purpose of the high-speed interface is to transfer pixel data rapidly and efficiently, making use of high speed DDR transfer and compression techniques to save power and time. The high-speed interface is composed of differential SubLVDS receivers for inputs, with a dedicated clock.

### 7.3.4 Timing

The data sheet provides timing at the device pin. For output timing analysis, the tester pin electronics and its transmission line effects must be taken into account. [Figure 13](#) shows an equivalent test load circuit for the output under test. Timing reference loads are not intended as a precise representation of any particular system environment or depiction of the actual load presented by a production test. System designers should use IBIS or other simulation tools to correlate the timing reference load to a system environment. The load capacitance value stated is only for characterization and measurement of AC timing signals. This load capacitance value does not indicate the maximum load the device is capable of driving.

## 7.4 Device Functional Modes

DMD functional modes are controlled by the DLPC3439 or DLPC3479 controller. See the [DLPC3439/ DLPC3479](#) controller data sheet or contact a TI applications engineer.

## 7.5 Optical Interface and System Image Quality Considerations

### 7.5.1 Optical Interface and System Image Quality

TI assumes no responsibility for end-equipment optical performance. Achieving the desired end-equipment optical performance involves making trade-offs between numerous component and system design parameters. Optimizing system optical performance and image quality strongly relate to optical system design parameter trades. Although it is not possible to anticipate every conceivable application, projector image quality and optical performance is contingent on compliance to the optical system operating conditions described in the following sections.

#### 7.5.1.1 Numerical Aperture and Stray Light Control

The angle defined by the numerical aperture of the illumination and projection optics at the DMD optical area should be the same. This angle should not exceed the nominal device micromirror tilt angle unless appropriate apertures are added in the illumination and/or projection pupils to block out flat-state and stray light from the projection lens. The micromirror tilt angle defines DMD capability to separate the "ON" optical path from any other light path, including undesirable flat-state specular reflections from the DMD window, DMD border structures, or other system surfaces near the DMD such as prism or lens surfaces. If the numerical aperture exceeds the micromirror tilt angle, or if the projection numerical aperture angle is more than two degrees larger than the illumination numerical aperture angle (and vice versa), contrast degradation and objectionable artifacts in the display border and/or active area could occur.

#### 7.5.1.2 Pupil Match

TI's optical and image quality specifications assume that the exit pupil of the illumination optics is nominally centered within 2° of the entrance pupil of the projection optics. Misalignment of pupils can create objectionable artifacts in the display's border and/or active area, which may require additional system apertures to control, especially if the numerical aperture of the system exceeds the pixel tilt angle.



## Optical Interface and System Image Quality Considerations (continued)

### 7.5.1.3 Illumination Overfill

The active area of the device is surrounded by an aperture on the inside DMD window surface that masks structures of the DMD chip assembly from normal view, and is sized to anticipate several optical operating conditions. Overfill light illuminating the window aperture can create artifacts from the edge of the window aperture opening and other surface anomalies that may be visible on the screen. The illumination optical system should be designed to limit light flux incident anywhere on the window aperture from exceeding approximately 10% of the average flux level in the active area. Depending on the particular system's optical architecture, overfill light may have to be further reduced below the suggested 10% level in order to be acceptable.

## 7.6 Micromirror Array Temperature Calculation

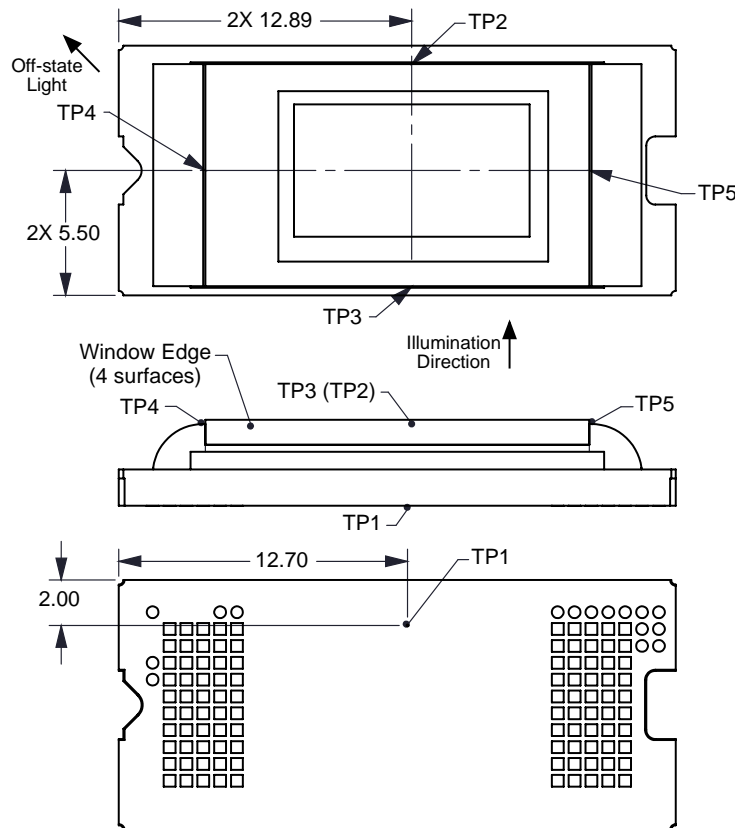

Figure 18. DMD Thermal Test Points

Micromirror array temperature can be computed analytically from measurement points on the outside of the package, the ceramic package thermal resistance, the electrical power dissipation, and the illumination heat load. The relationship between micromirror array temperature and the reference ceramic temperature is provided by the following equations:

$$T_{\text{ARRAY}} = T_{\text{CERAMIC}} + (Q_{\text{ARRAY}} \times R_{\text{ARRAY-TO-CERAMIC}}) \quad (1)$$

$$Q_{\text{ARRAY}} = Q_{\text{ELECTRICAL}} + Q_{\text{ILLUMINATION}} \quad (2)$$

$$Q_{\text{ILLUMINATION}} = (C_{L2W} \times SL)$$

- $T_{\text{ARRAY}}$  = Computed DMD array temperature (°C)
- $T_{\text{CERAMIC}}$  = Measured ceramic temperature (°C), TP1 location in [Figure 18](#)
- $R_{\text{ARRAY-TO-CERAMIC}}$  = DMD package thermal resistance from array to outside ceramic (°C/W) specified in [Thermal Information](#)
- $Q_{\text{ARRAY}}$  = Total DMD power; electrical plus absorbed (calculated) (W)
- $Q_{\text{ELECTRICAL}}$  = Nominal DMD electrical power dissipation (W)
- $C_{L2W}$  = Conversion constant for screen lumens to absorbed optical power on the DMD (W/lm) specified below

## Micromirror Array Temperature Calculation (continued)

- $SL = \text{Measured ANSI screen lumens (lm)}$  (3)

Electrical power dissipation of the DMD is variable and depends on the voltages, data rates and operating frequencies. A nominal electrical power dissipation to use when calculating array temperature is 0.25W. Absorbed optical power from the illumination source is variable and depends on the operating state of the micromirrors and the intensity of the light source. Equations shown above are valid for a 1-chip DMD system with total projection efficiency through the projection lens from DMD to the screen of 87%.

The conversion constant CL2W is based on the DMD micromirror array characteristics. It assumes a spectral efficiency of 300 lm/W for the projected light and illumination distribution of 83.7% on the DMD active array, and 16.3% on the DMD array border and window aperture. The conversion constant is calculated to be 0.00266 W/lm.

Sample Calculation for typical projection application:

1.  $T_{\text{CERAMIC}} = 55^{\circ}\text{C}$ , assumed system measurement; see [Recommended Operating Conditions](#) for specification limits.
2.  $SL = 1500 \text{ lm}$
3.  $Q_{\text{ELECTRICAL}} = 0.25 \text{ W}$
4.  $CL2W = 0.00266 \text{ W/lm}$
5.  $Q_{\text{ARRAY}} = 0.25 + (0.00266 \times 1500) = 4.24 \text{ W}$
6.  $T_{\text{ARRAY}} = 55^{\circ}\text{C} + (4.24 \text{ W} \times 1.1^{\circ}\text{C/W}) = 59.66^{\circ}\text{C}$

## 7.7 Micromirror Landed-On/Landed-Off Duty Cycle

### 7.7.1 Definition of Micromirror Landed-On/Landed-Off Duty Cycle

The micromirror landed-on/landed-off duty cycle (landed duty cycle) denotes the amount of time (as a percentage) that an individual micromirror is landed in the ON state versus the amount of time the same micromirror is landed in the OFF state.

As an example, a landed duty cycle of 75/25 indicates that the referenced pixel is in the ON state 75% of the time and in the OFF state 25% of the time, whereas 25/75 would indicate that the pixel is in the ON state 25% of the time. Likewise, 50/50 indicates that the pixel is ON 50% of the time and OFF 50% of the time.

Note that when assessing landed duty cycle, the time spent switching from one state (ON or OFF) to the other state (OFF or ON) is considered negligible and is thus ignored.

Since a micromirror can only be landed in one state or the other (ON or OFF), the two numbers (percentages) nominally add to 100.

### 7.7.2 Landed Duty Cycle and Useful Life of the DMD

Knowing the long-term average landed duty cycle (of the end product or application) is important because subjecting all (or a portion) of the DMD's micromirror array (also called the active array) to an asymmetric landed duty cycle for a prolonged period of time can reduce the DMD's usable life.

Note that it is the symmetry/asymmetry of the landed duty cycle that is of relevance. The symmetry of the landed duty cycle is determined by how close the two numbers (percentages) are to being equal. For example, a landed duty cycle of 50/50 is perfectly symmetrical whereas a landed duty cycle of 100/0 or 0/100 is perfectly asymmetrical.

### 7.7.3 Landed Duty Cycle and Operational DMD Temperature

Operational DMD Temperature and Landed Duty Cycle interact to affect the DMD's usable life, and this interaction can be exploited to reduce the impact that an asymmetrical Landed Duty Cycle has on the DMD's usable life. This is quantified in the de-rating curve shown in [Figure 1](#). The importance of this curve is that:

- All points along this curve represent the same usable life.
- All points above this curve represent lower usable life (and the further away from the curve, the lower the usable life).

## Micromirror Landed-On/Landed-Off Duty Cycle (continued)

- All points below this curve represent higher usable life (and the further away from the curve, the higher the usable life).

In practice, this curve specifies the Maximum Operating DMD Temperature that the DMD should be operated at for a given long-term average Landed Duty Cycle.

### 7.7.4 Estimating the Long-Term Average Landed Duty Cycle of a Product or Application

During a given period of time, the nominal landed duty cycle of a given pixel is determined by the image content being displayed by that pixel.

For example, in the simplest case, when displaying pure-white on a given pixel for a given time period, that pixel will experience very close to a 100/0 landed duty cycle during that time period. Likewise, when displaying pure-black, the pixel will experience very close to a 0/100 landed duty cycle.

Between the two extremes (ignoring for the moment color and any image processing that may be applied to an incoming image), the landed duty cycle tracks one-to-one with the gray scale value, as shown in [Table 1](#).

**Table 1. Grayscale Value and Landed Duty Cycle**

Grayscale Value	Nominal Landed Duty Cycle
0%	0/100
10%	10/90
20%	20/80
30%	30/70
40%	40/60
50%	50/50
60%	60/40
70%	70/30
80%	80/20
90%	90/10
100%	100/0

Accounting for color rendition (but still ignoring image processing) requires knowing both the color intensity (from 0% to 100%) for each constituent primary color (red, green, and/or blue) for the given pixel as well as the color cycle time for each primary color, where “color cycle time” is the total percentage of the frame time that a given primary must be displayed in order to achieve the desired white point.

During a given period of time, the landed duty cycle of a given pixel can be calculated as follows:

$$\text{Landed Duty Cycle} = (\text{Red\_Cycle\_}\% \times \text{Red\_Scale\_Value}) + (\text{Green\_Cycle\_}\% \times \text{Green\_Scale\_Value}) + (\text{Blue\_Cycle\_}\% \times \text{Blue\_Scale\_Value})$$

where

Red\_Cycle\_%, Green\_Cycle\_%, and Blue\_Cycle\_% represent the percentage of the frame time that Red, Green, and Blue are displayed (respectively) to achieve the desired white point. (4)

For example, assume that the red, green and blue color cycle times are 50%, 20%, and 30% respectively (in order to achieve the desired white point), then the Landed Duty Cycle for various combinations of red, green, blue color intensities would be as shown in [Table 2](#).

**Table 2. Example Landed Duty Cycle for Full-Color Pixels**

Red Cycle Percentage	Green Cycle Percentage	Blue Cycle Percentage
50%	20%	30%

Red Scale Value	Green Scale Value	Blue Scale Value	Nominal Landed Duty Cycle
0%	0%	0%	0/100
100%	0%	0%	50/50
0%	100%	0%	20/80
0%	0%	100%	30/70
12%	0%	0%	6/94
0%	35%	0%	7/93
0%	0%	60%	18/82
100%	100%	0%	70/30
0%	100%	100%	50/50
100%	0%	100%	80/20
12%	35%	0%	13/87
0%	35%	60%	25/75
12%	0%	60%	24/76
100%	100%	100%	100/0

The last factor to account for in estimating the Landed Duty Cycle is any applied image processing. Within the DLP Controller DLPC3439 or DLPC3479, the two functions which affect Landed Duty Cycle are Gamma and IntelliBright™.

Gamma is a power function of the form  $Output\_Level = A \times Input\_Level^{Gamma}$ , where A is a scaling factor that is typically set to 1.

In the DLPC3430/DLPC3435 controller, gamma is applied to the incoming image data on a pixel-by-pixel basis. A typical gamma factor is 2.2, which transforms the incoming data as shown in Figure 19.

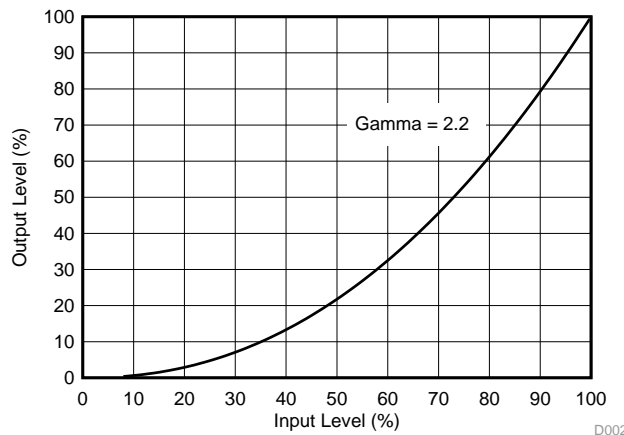

Figure 19. Example of Gamma = 2.2

From Figure 19, if the gray scale value of a given input pixel is 40% (before gamma is applied), then gray scale value will be 13% after gamma is applied. Therefore, it can be seen that since gamma has a direct impact displayed gray scale level of a pixel, it also has a direct impact on the landed duty cycle of a pixel.

The IntelliBright algorithms content adaptive illumination control (CAIC) and local area brightness boost (LABB) also apply transform functions on the gray scale level of each pixel.

But while amount of gamma applied to every pixel (of every frame) is constant (the exponent, gamma, is constant), CAIC and LABB are both adaptive functions that can apply a different amounts of either boost or compression to every pixel of every frame.

Consideration must also be given to any image processing which occurs before the DLPC3439 or DLPC3479 controller.

## 8 Application and Implementation

---

### NOTE

Information in the following applications sections is not part of the TI component specification, and TI does not warrant its accuracy or completeness. TI's customers are responsible for determining suitability of components for their purposes. Customers should validate and test their design implementation to confirm system functionality.

---

### 8.1 Application Information

The DMDs are spatial light modulators which reflect incoming light from an illumination source to one of two directions, with the primary direction being into a projection or collection optic. Each application is derived primarily from the optical architecture of the system and the format of the data coming into the dual DLPC3439 or DLPC3479 controllers. The new high tilt pixel in the bottom-illuminated DMD increases brightness performance and enables a smaller system footprint for thickness constrained applications. Applications of interest include projection embedded in display devices like smartphones, tablets, cameras, and camcorders. Other applications include wearable (near-eye) displays, battery powered mobile accessory, interactive display, low-latency gaming display, and digital signage.

DMD power-up and power-down sequencing is strictly controlled by the DLPA3000/DLPA3005. Refer to Power Supply Recommendations for power-up and power-down specifications. To ensure reliable operation, the DLP4710 DMD must always be used with two DLPC3439 or DLPC3479 controllers and a DLPA3000 or DLPA3005 PMIC/LED driver.

### 8.2 Typical Application

A pico-projector that can be used as an accessory to a smartphone, tablet or a laptop is a common application when using a DLP4710 DMD and two DLPC3439 or DLPC3479 devices. The two DLPC3439 or DLPC3479 devices in the pico-projector receive images from a multimedia front end within the product as shown in [Figure 20](#).

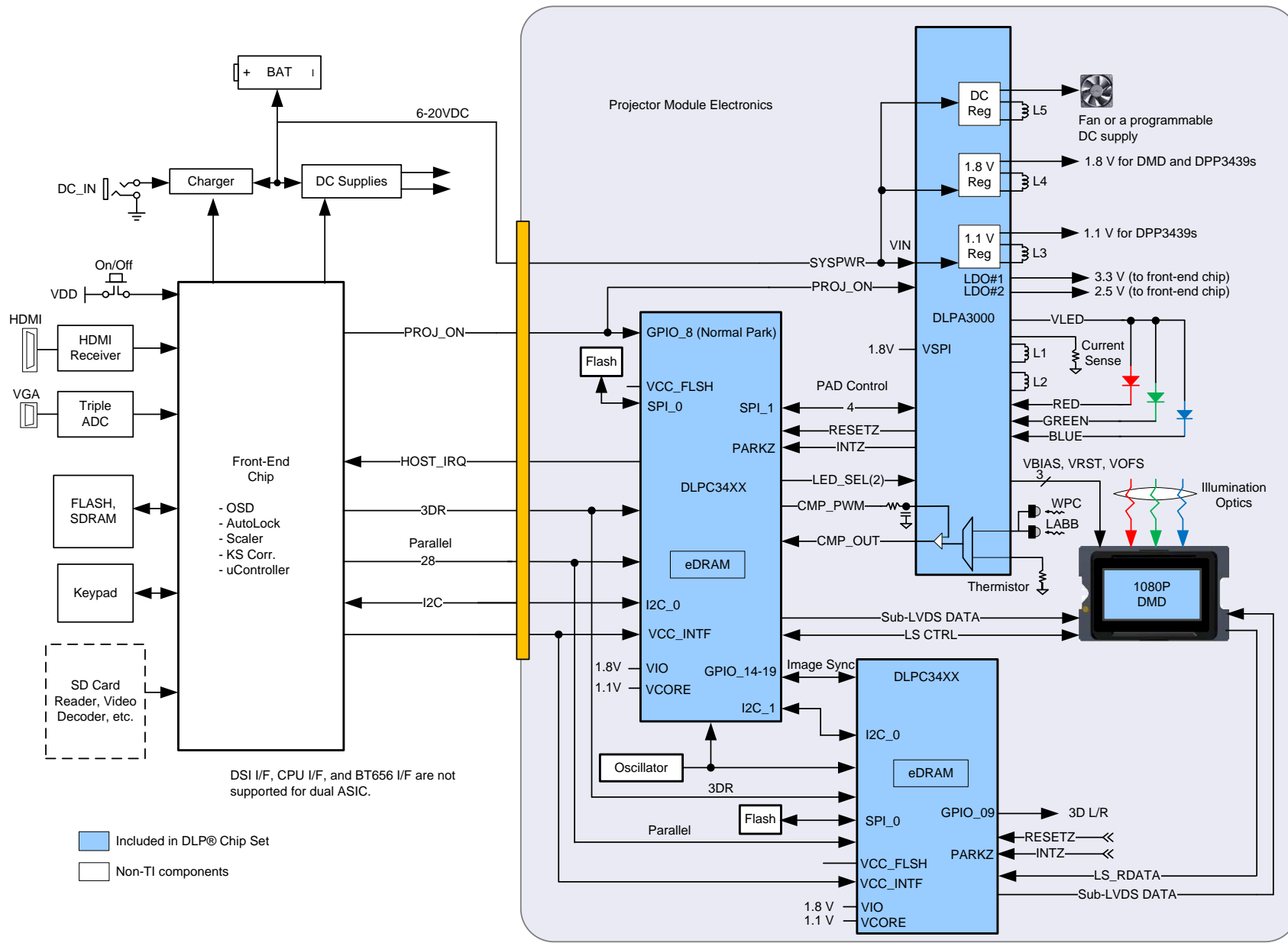

Figure 20. Typical Application Diagram

### 8.2.1 Design Requirements

A pico-projector is created by using a DLP chip set comprised of a DLP4710 DMD, two DLPC3439 or DLPC3479 controllers and a DLPA3000/DLPA3005 PMIC/LED driver. The DLPC3439 or DLPC3479 controllers do the digital image processing, the DLPA3000/DLPA3005 provides the needed analog functions for the projector, and the DLP4710 DMD is the display device for producing the projected image.

In addition to the three DLP chips in the chip set, other chips are needed. At a minimum a Flash part is needed to store the software and firmware to control each DLPC3439 or DLPC3479 controller.

The illumination light that is applied to the DMD is typically from red, green, and blue LEDs. These are often contained in three separate packages, but sometimes more than one color of LED die may be in the same package to reduce the overall size of the pico-projector.

For connecting the DLPC3439 or DLPC3479 controllers to the multimedia front end for receiving images, a 24-bit parallel interface is used. An I2C interface should be connected to the multimedia front end for sending commands to one of the DLPC3439 or DLPC3479 controllers for configuring the DLPC3439 or DLPC3479 controller for different features.

### 8.2.2 Detailed Design Procedure

For connecting the two DLPC3439 or DLPC3479 controllers, the DLPA3000/DLPA3005, and the DLP4710 DMD, see the reference design schematic. When a circuit board layout is created from this schematic a very small circuit board is possible. An example small board layout is included in the reference design data base. Layout guidelines should be followed to achieve a reliable projector.

The optical engine that has the LED packages and the DMD mounted to it is typically supplied by an optical OEM who specializes in designing optics for DLP projectors.

### 8.2.3 Application Curve

As the LED currents that are driven time-sequentially through the red, green, and blue LEDs are increased, the brightness of the projector increases. This increase is somewhat non-linear, and the curve for typical white screen lumens changes with LED currents is as shown in [Figure 21](#). For the LED currents shown, it's assumed that the same current amplitude is applied to the red, green, and blue LEDs.

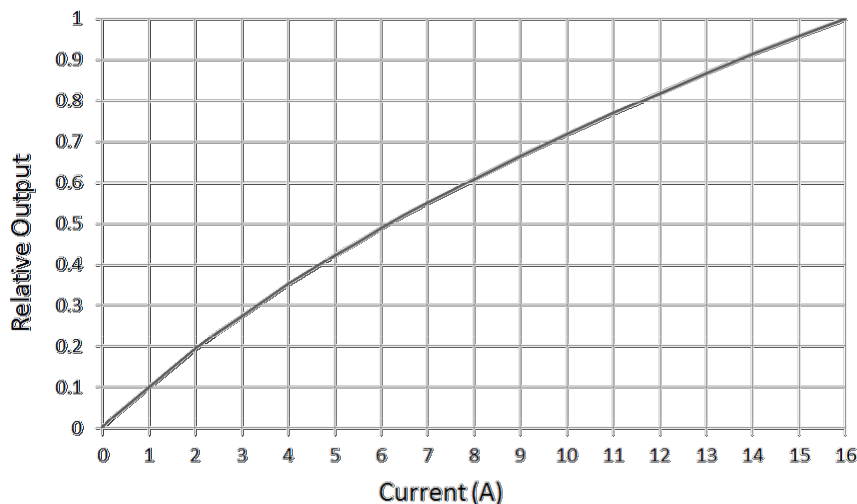

**Figure 21. Luminance vs Current**

## 9 Power Supply Recommendations

The following power supplies are all required to operate the DMD: VDD, VDDI, VOFFSET, VBIAS, and VRESET. All VSS connections are also required. DMD power-up and power-down sequencing is strictly controlled by the DLPA3000/DLPA3005 devices.

### CAUTION

For reliable operation of the DMD, the following power supply sequencing requirements must be followed. Failure to adhere to the prescribed power-up and power-down procedures may affect device reliability.

VDD, VDDI, VOFFSET, VBIAS, and VRESET power supplies have to be coordinated during power-up and power-down operations. Failure to meet any of the below requirements will result in a significant reduction in the DMD's reliability and lifetime. Refer to [Figure 23](#). VSS must also be connected.

### 9.1 Power Supply Power-Up Procedure

- During power-up, VDD and VDDI must always start and settle before VOFFSET, VBIAS, and VRESET voltages are applied to the DMD.
- During power-up, it is a strict requirement that the delta between VBIAS and VOFFSET must be within the specified limit shown in [Recommended Operating Conditions](#). Refer to [Table 3](#) and the [Layout Example](#) for power-up delay requirements.
- During power-up, the DMD's LPSDR input pins shall not be driven high until after VDD and VDDI have settled at operating voltage.
- During power-up, there is no requirement for the relative timing of VRESET with respect to VOFFSET and VBIAS. Power supply slew rates during power-up are flexible, provided that the transient voltage levels follow the requirements listed previously and in [Figure 22](#).

### 9.2 Power Supply Power-Down Procedure

- Power-down sequence is the reverse order of the previous power-up sequence. VDD and VDDI must be supplied until after VBIAS, VRESET, and VOFFSET are discharged to within 4 V of ground.
- During power-down, it is not mandatory to stop driving VBIAS prior to VOFFSET, but it is a strict requirement that the delta between VBIAS and VOFFSET must be within the specified limit shown in [Recommended Operating Conditions](#) (Refer to Note 2 for [Figure 22](#)).
- During power-down, the DMD's LPSDR input pins must be less than VDDI, the specified limit shown in [Recommended Operating Conditions](#).
- During power-down, there is no requirement for the relative timing of VRESET with respect to VOFFSET and VBIAS.
- Power supply slew rates during power-down are flexible, provided that the transient voltage levels follow the requirements listed previously and in [Figure 22](#).





**Power Supply Sequencing Requirements (continued)**

**Table 3. Power-Up Sequence Delay Requirement**

PARAMETER		MIN	MAX	UNIT
$t_{DELAY}$	Delay requirement from VOFFSET power up to VBIAS power up	2		ms
$V_{OFFSET}$	Supply voltage level at beginning of power-up sequence delay (see Figure 23)		6	V
$V_{BIAS}$	Supply voltage level at end of power-up sequence delay (see Figure 23)		6	V

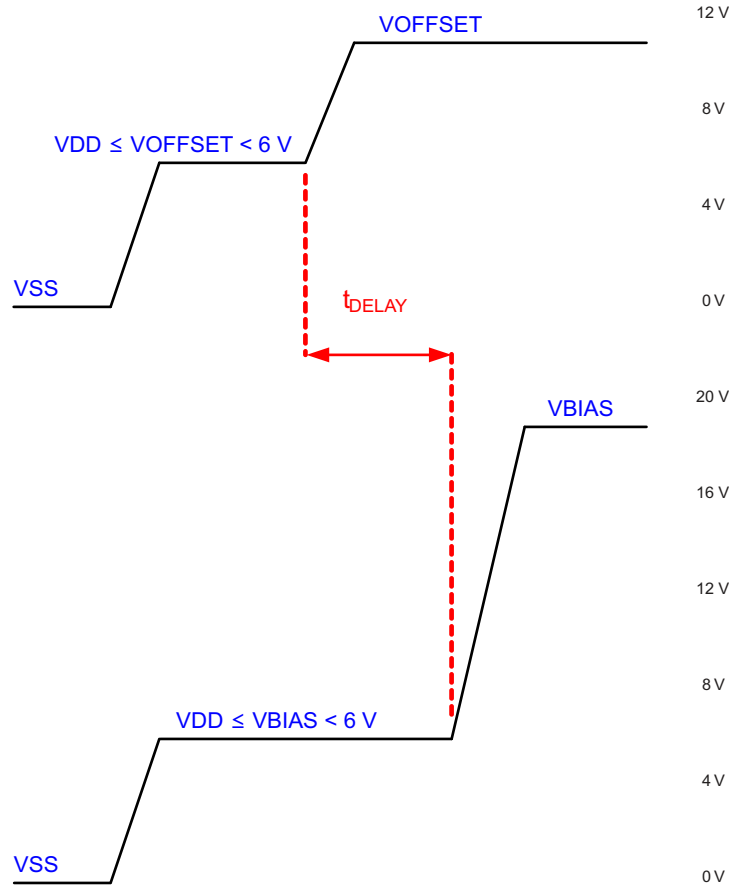

Refer to Table 3 for VOFFSET and VBIAS supply voltage levels during power-up sequence delay.

**Figure 23. Power-Up Sequence Delay Requirement**

## 10 Layout

### 10.1 Layout Guidelines

There are no specific layout guidelines for the DMD as typically DMD is connected using a board to board connector to a flex cable. Flex cable provides the interface of data and Ctrl signals between the DLPC343x controller and the DLP4710 DMD. For detailed layout guidelines refer to the layout design files. Some layout guideline for the flex cable interface with DMD are:

- Match lengths for the LS\_WDATA and LS\_CLK signals.
- Minimize vias, layer changes, and turns for the HS bus signals. Refer [Figure 24](#).
- Minimum of two 220-nF decoupling capacitor close to VBIAS. Capacitor C3 and C10 in [Figure 24](#).
- Minimum of two 220-nF decoupling capacitor close to VRST. Capacitor C1 and C9 in [Figure 24](#).
- Minimum of two 220-nF decoupling capacitor close to VOFS. Capacitor C2 and C8 in [Figure 24](#).
- Minimum of four 220-nF decoupling capacitor close to VDDI and VDD. Capacitor C4, C5, C6 and C7 in [Figure 24](#).

### 10.2 Layout Example

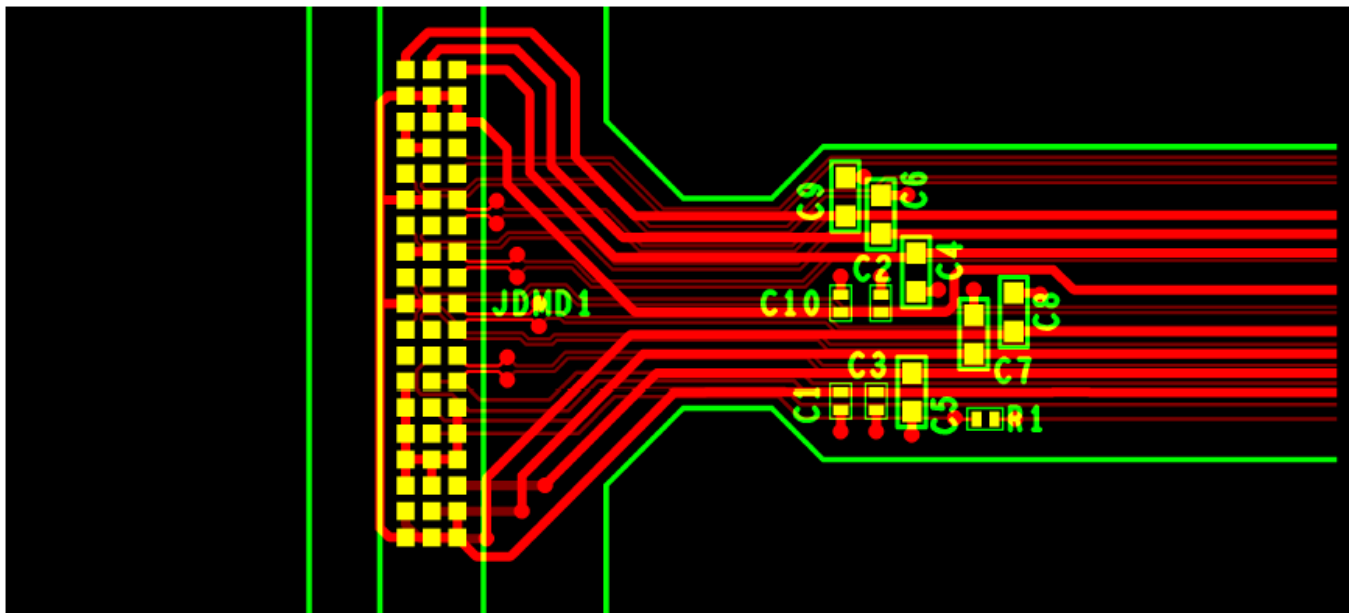

Figure 24. Power Supply Connections

## 11 Device and Documentation Support

### 11.1 Device Support

#### 11.1.1 Device Nomenclature

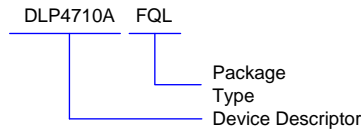

Figure 25. Part Number Description

#### 11.1.2 Device Markings

The device marking includes the legible character string GHJJJK DLP4710AFQL. GHJJJK is the lot trace code. DLP4710AFQL is the device marking.

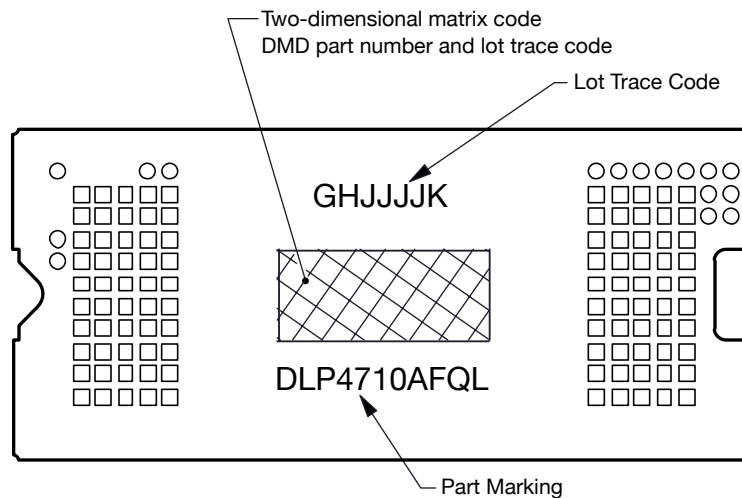

Figure 26. DMD Marking Locations

### 11.2 Related Links

The table below lists quick access links. Categories include technical documents, support and community resources, tools and software, and quick access to sample or buy.

Table 4. Related Links

PARTS	PRODUCT FOLDER	SAMPLE & BUY	TECHNICAL DOCUMENTS	TOOLS & SOFTWARE	SUPPORT & COMMUNITY
DLP4710	<a href="#">Click here</a>	<a href="#">Click here</a>	<a href="#">Click here</a>	<a href="#">Click here</a>	<a href="#">Click here</a>
DLPC3439	<a href="#">Click here</a>	<a href="#">Click here</a>	<a href="#">Click here</a>	<a href="#">Click here</a>	<a href="#">Click here</a>
DLPC3479	<a href="#">Click here</a>	<a href="#">Click here</a>	<a href="#">Click here</a>	<a href="#">Click here</a>	<a href="#">Click here</a>
DLPA3000	<a href="#">Click here</a>	<a href="#">Click here</a>	<a href="#">Click here</a>	<a href="#">Click here</a>	<a href="#">Click here</a>
DLPA3005	<a href="#">Click here</a>	<a href="#">Click here</a>	<a href="#">Click here</a>	<a href="#">Click here</a>	<a href="#">Click here</a>

### 11.3 Community Resources

The following links connect to TI community resources. Linked contents are provided "AS IS" by the respective contributors. They do not constitute TI specifications and do not necessarily reflect TI's views; see TI's [Terms of Use](#).

## Community Resources (continued)

**TI E2E™ Online Community** *TI's Engineer-to-Engineer (E2E) Community*. Created to foster collaboration among engineers. At [e2e.ti.com](http://e2e.ti.com), you can ask questions, share knowledge, explore ideas and help solve problems with fellow engineers.

**Design Support** *TI's Design Support* Quickly find helpful E2E forums along with design support tools and contact information for technical support.

### 11.4 Trademarks

Pico, IntelliBright, E2E are trademarks of Texas Instruments.  
DLP is a registered trademark of Texas Instruments.  
All other trademarks are the property of their respective owners.

### 11.5 Electrostatic Discharge Caution



These devices have limited built-in ESD protection. The leads should be shorted together or the device placed in conductive foam during storage or handling to prevent electrostatic damage to the MOS gates.

### 11.6 Glossary

[SLYZ022](#) — *TI Glossary*.

This glossary lists and explains terms, acronyms, and definitions.

## 12 Mechanical, Packaging, and Orderable Information

The following pages include mechanical, packaging, and orderable information. This information is the most current data available for the designated devices. This data is subject to change without notice and revision of this document. For browser-based versions of this data sheet, refer to the left-hand navigation.

**PACKAGING INFORMATION**

Orderable Device	Status (1)	Package Type	Package Drawing	Pins	Package Qty	Eco Plan (2)	Lead/Ball Finish (6)	MSL Peak Temp (3)	Op Temp (°C)	Device Marking (4/5)	Samples
DLP4710AFQL	ACTIVE	CLGA	FQL	100	80	RoHS & Green	Call TI	Level-1-NC-NC			Samples

(1) The marketing status values are defined as follows:

**ACTIVE:** Product device recommended for new designs.

**LIFEBUY:** TI has announced that the device will be discontinued, and a lifetime-buy period is in effect.

**NRND:** Not recommended for new designs. Device is in production to support existing customers, but TI does not recommend using this part in a new design.

**PREVIEW:** Device has been announced but is not in production. Samples may or may not be available.

**OBSELETE:** TI has discontinued the production of the device.

(2) **RoHS:** TI defines "RoHS" to mean semiconductor products that are compliant with the current EU RoHS requirements for all 10 RoHS substances, including the requirement that RoHS substance do not exceed 0.1% by weight in homogeneous materials. Where designed to be soldered at high temperatures, "RoHS" products are suitable for use in specified lead-free processes. TI may reference these types of products as "Pb-Free".

**RoHS Exempt:** TI defines "RoHS Exempt" to mean products that contain lead but are compliant with EU RoHS pursuant to a specific EU RoHS exemption.

**Green:** TI defines "Green" to mean the content of Chlorine (Cl) and Bromine (Br) based flame retardants meet JS709B low halogen requirements of <=1000ppm threshold. Antimony trioxide based flame retardants must also meet the <=1000ppm threshold requirement.

(3) MSL, Peak Temp. - The Moisture Sensitivity Level rating according to the JEDEC industry standard classifications, and peak solder temperature.

(4) There may be additional marking, which relates to the logo, the lot trace code information, or the environmental category on the device.

(5) Multiple Device Markings will be inside parentheses. Only one Device Marking contained in parentheses and separated by a "~" will appear on a device. If a line is indented then it is a continuation of the previous line and the two combined represent the entire Device Marking for that device.

(6) Lead/Ball Finish - Orderable Devices may have multiple material finish options. Finish options are separated by a vertical ruled line. Lead/Ball Finish values may wrap to two lines if the finish value exceeds the maximum column width.

**Important Information and Disclaimer:** The information provided on this page represents TI's knowledge and belief as of the date that it is provided. TI bases its knowledge and belief on information provided by third parties, and makes no representation or warranty as to the accuracy of such information. Efforts are underway to better integrate information from third parties. TI has taken and continues to take reasonable steps to provide representative and accurate information but may not have conducted destructive testing or chemical analysis on incoming materials and chemicals. TI and TI suppliers consider certain information to be proprietary, and thus CAS numbers and other limited information may not be available for release.

In no event shall TI's liability arising out of such information exceed the total purchase price of the TI part(s) at issue in this document sold by TI to Customer on an annual basis.

NOTES UNLESS OTHERWISE SPECIFIED:

- 1 NOTCH DIMENSIONS ARE DEFINED BY UPPERMOST LAYERS OF CERAMIC, AS SHOWN IN SECTION A-A.
- 2 SEE DETAIL B FOR "V-NOTCH" DIMENSIONS.
- 3 DIE PARALLELISM TOLERANCE APPLIES TO DMD ACTIVE ARRAY ONLY.
- 4 WHILE ONLY THE THREE DATUM A TARGET AREAS A1, A2, AND A3 ARE USED FOR MEASUREMENT, ALL 4 CORNERS SHOULD BE CONTACTED, INCLUDING E1, TO SUPPORT MECHANICAL LOADS.
- 5 ENCAPSULANT TO BE CONTAINED WITHIN DIMENSIONS SHOWN IN VIEW D (SHEET 2). NO ENCAPSULANT IS ALLOWED ON TOP OF THE WINDOW.
- 6 ENCAPSULANT NOT TO EXCEED THE HEIGHT OF THE WINDOW.
- 7 ROTATION ANGLE OF DMD ACTIVE ARRAY IS A REFINEMENT OF THE LOCATION TOLERANCE AND HAS A MAXIMUM ALLOWED VALUE OF 0.6 DEGREES.
- 8 BOUNDARY MIRRORS SURROUNDING THE DMD ACTIVE ARRAY.

© COPYRIGHT 2014 TEXAS INSTRUMENTS  
UN-PUBLISHED. ALL RIGHTS RESERVED.

REVISIONS			
REV	DESCRIPTION	DATE	BY
A	ECO 2140050: INITIAL RELEASE	2/20/2014	BMH
B	ECO 2140429: CORRECT DATUM C IN VIEW J-J, SH. 3	3/6/2014	BMH
C	ECO 2142093: DELETE BACK SIDE FLATNESS SPEC	5/22/2014	BMH
D	ECO 2145057: ADD "FQL PACKAGE" TO DRAWING TITLE	7/20/2016	BMH

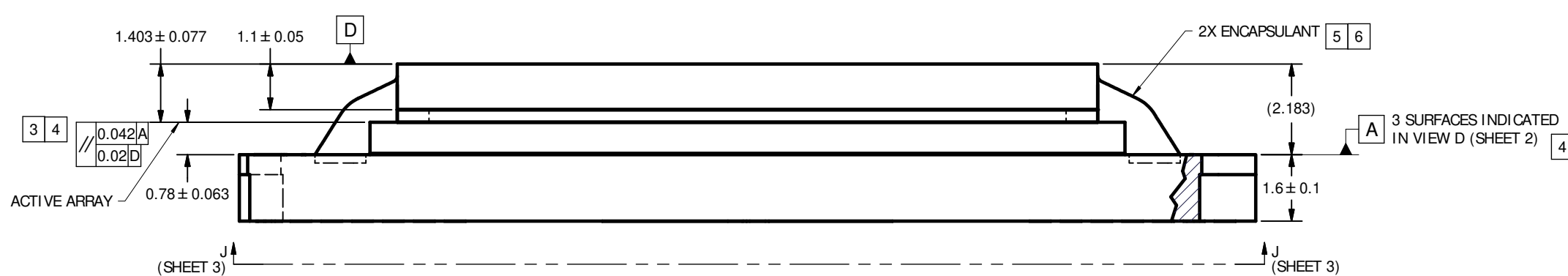
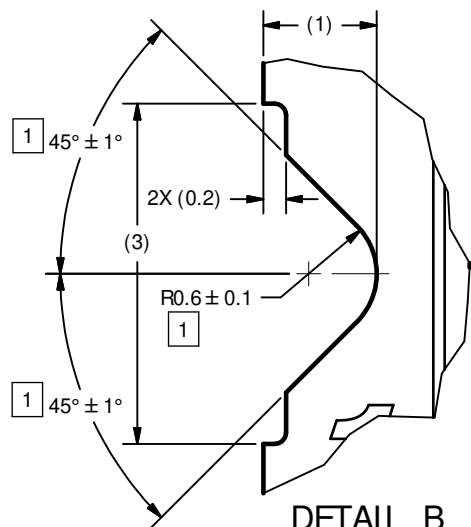
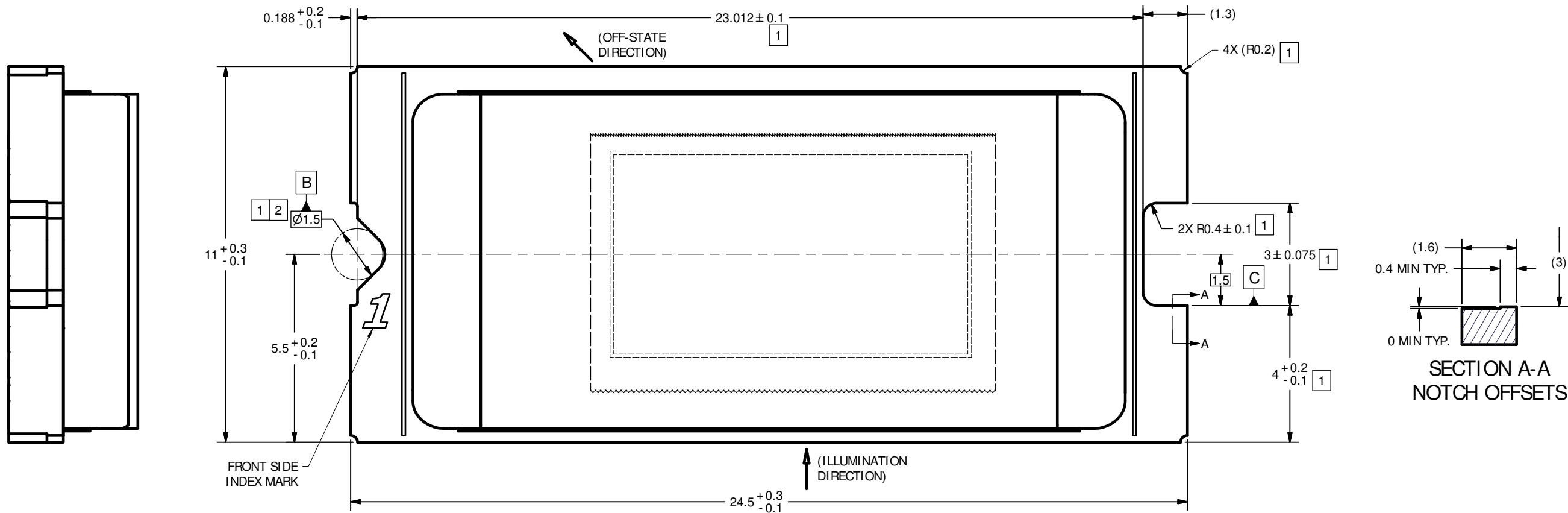

THIRD ANGLE PROJECTION 	0314DA	UNLESS OTHERWISE SPECIFIED	DRAWN B. HASKETT	DATE 2/20/2014	TEXAS INSTRUMENTS Dallas, Texas TITLE ICD, MECHANICAL, DMD, .47 1080p SERIES 312 (FQL PACKAGE)	
	NEXT ASSY	USED ON	● DIMENSIONS ARE IN MILLIMETERS ● TOLERANCES: ANGLES ± 1° 2 PLACE DECIMALS ± 0.25 1 PLACE DECIMALS ± 0.50 ● DIMENSIONAL LIMITS APPLY BEFORE PROCEEDING ● INTERPRET DIMENSIONS IN ACCORDANCE WITH ASME Y14.5M-1994 ● REMOVE ALL BURRS AND SHARP EDGES ● PARENTHETICAL INFORMATION FOR REFERENCE ONLY	ENGINEER B. HASKETT 2/20/2014 QA/CE P. KONRAD 2/26/2014 CM S. SUSI 2/25/2014		SIZE D
	APPLICATION		APPROVED R. LONG 2/26/2014	DWG NO. 2513652		REV D
				SCALE 15:1		SHEET 1 OF 3

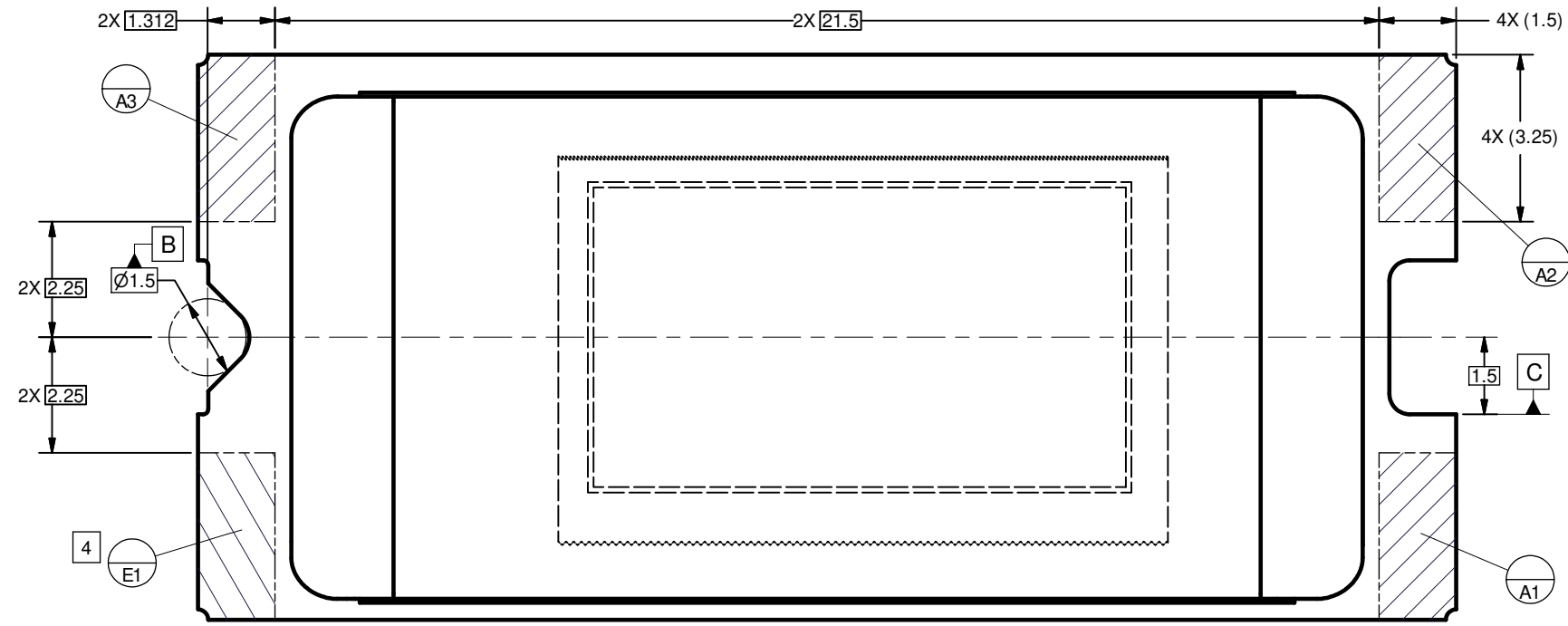

VIEW C  
DATUMS A AND E  
(SUBSTRATE METALLIZATION OMITTED FOR CLARITY)  
(FROM SHEET 1)

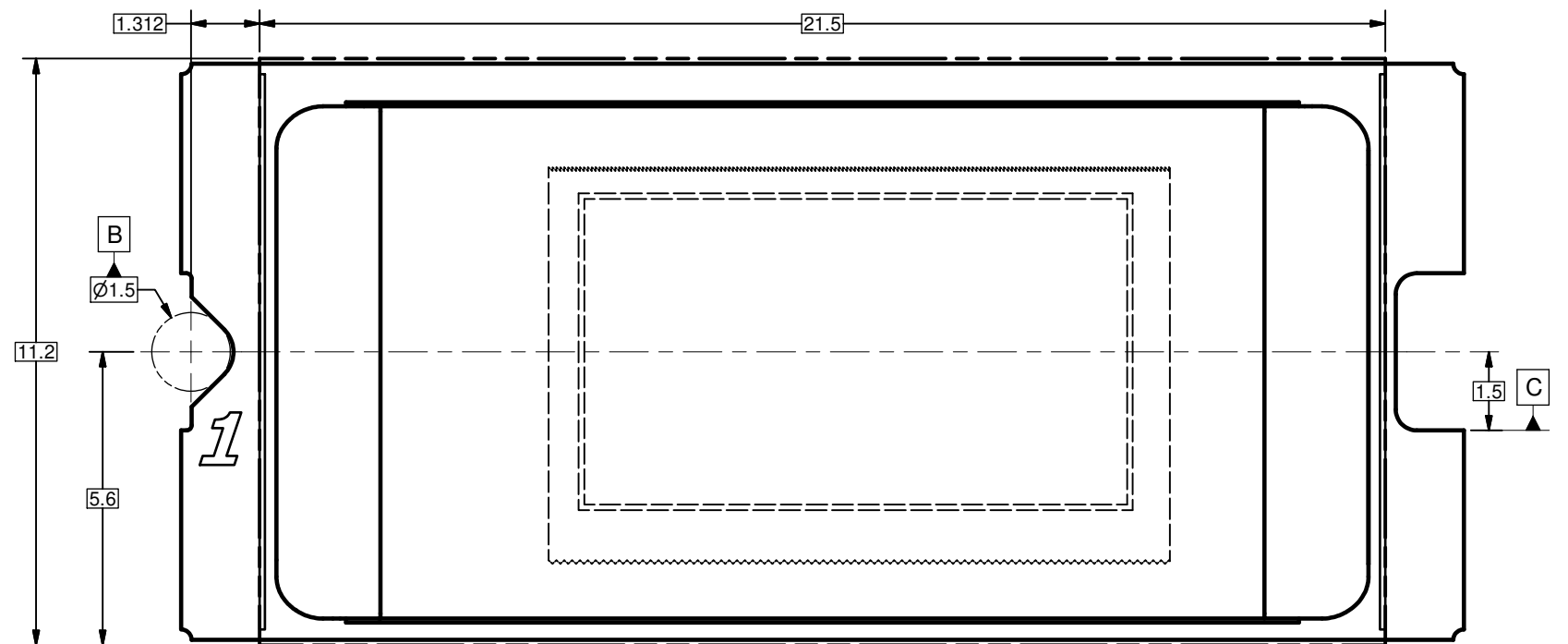

VIEW D  
ENCAPSULANT MAXIMUM X/Y DIMENSIONS [5]  
(FROM SHEET 1)

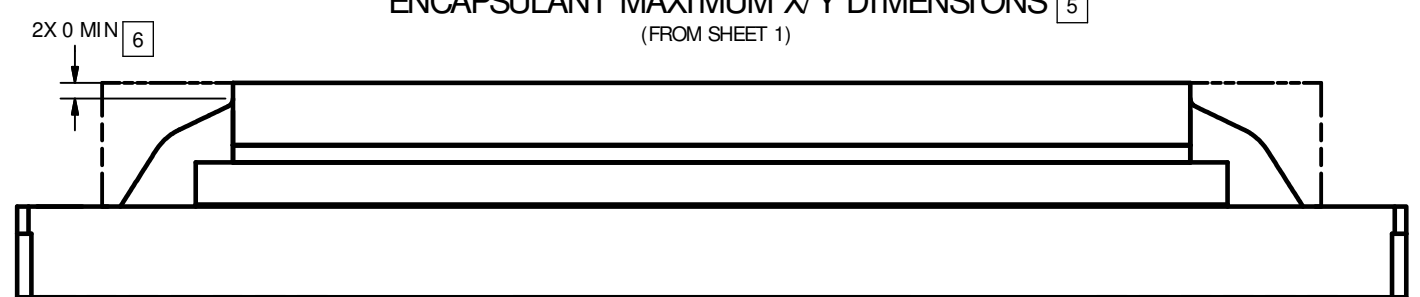

VIEW E  
ENCAPSULANT MAXIMUM HEIGHT



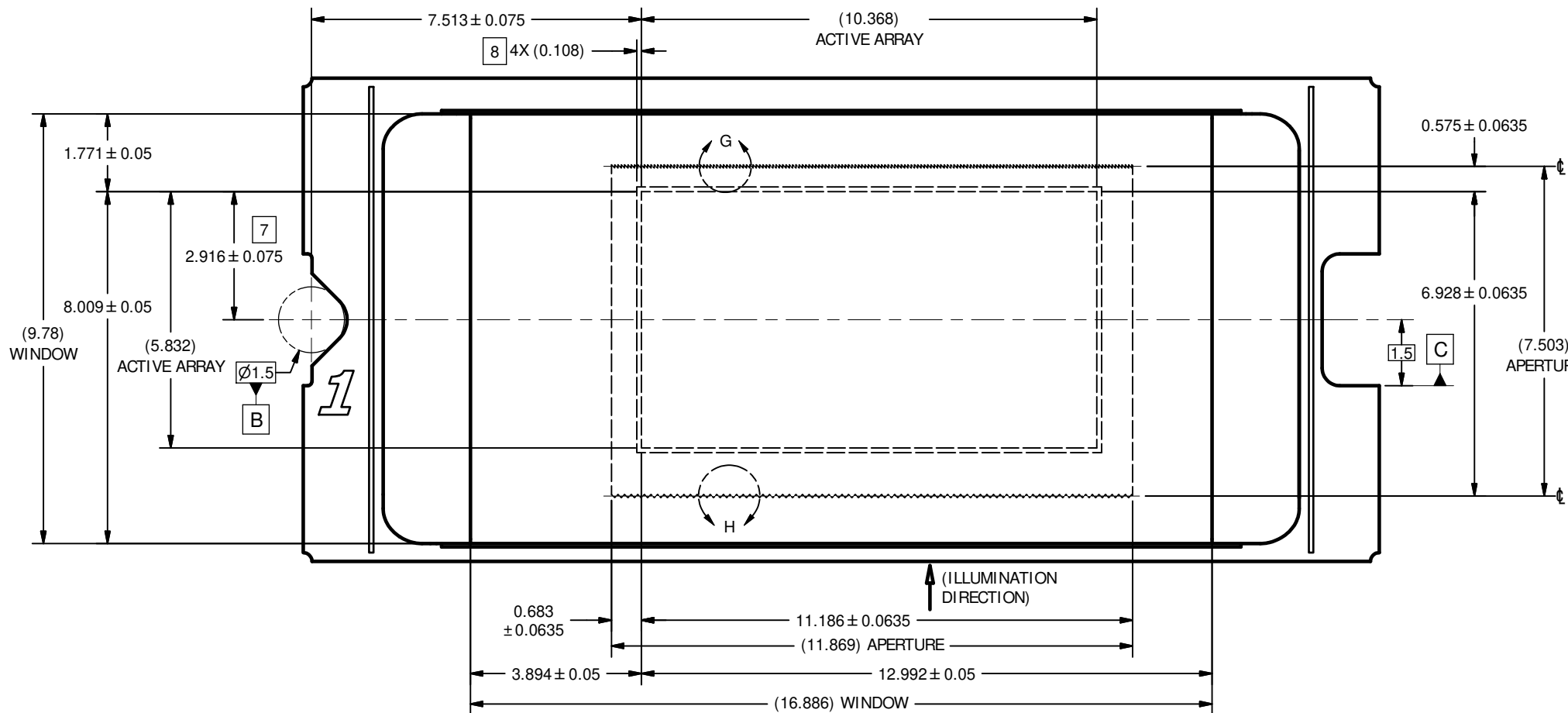

**VIEW F**  
WINDOW AND ACTIVE ARRAY  
(FROM SHEET 1)

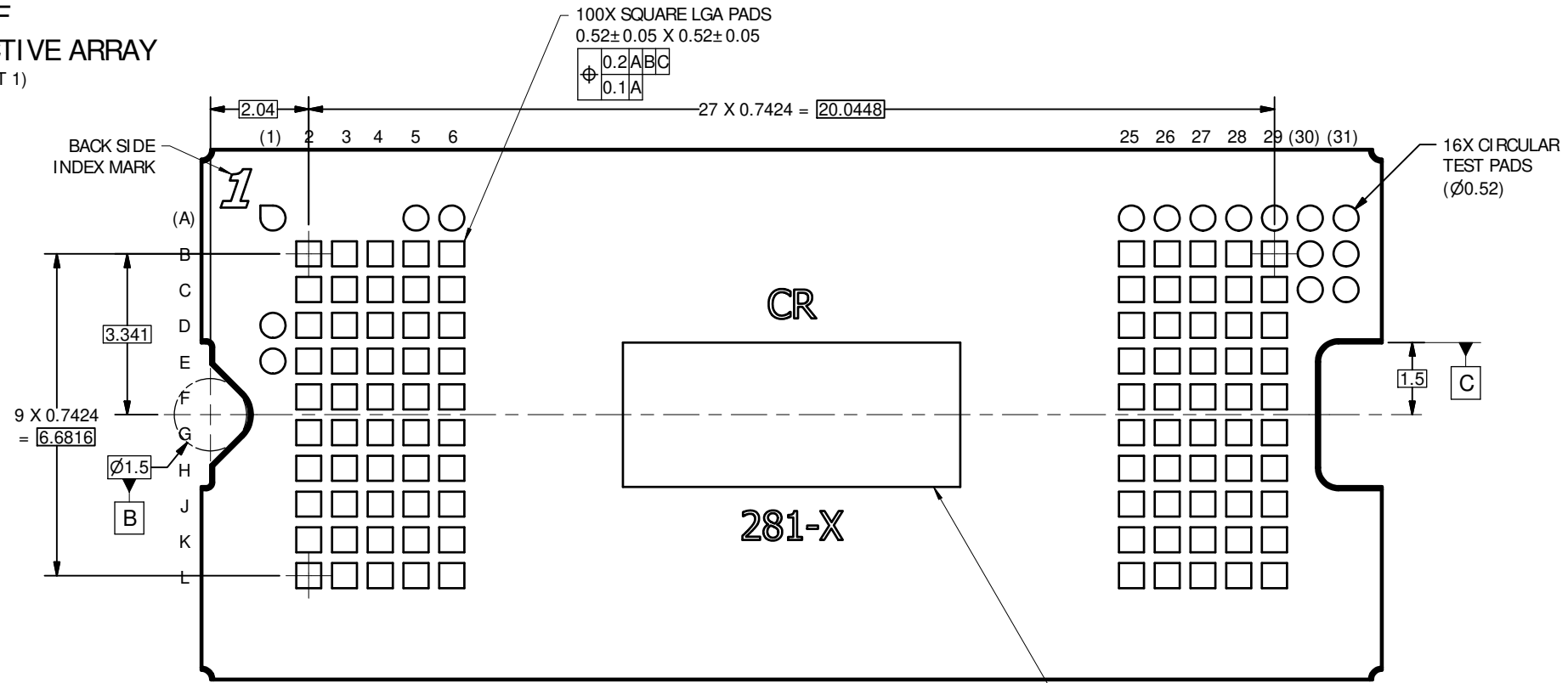
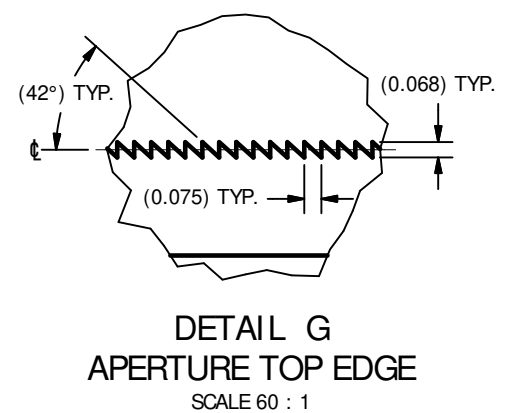
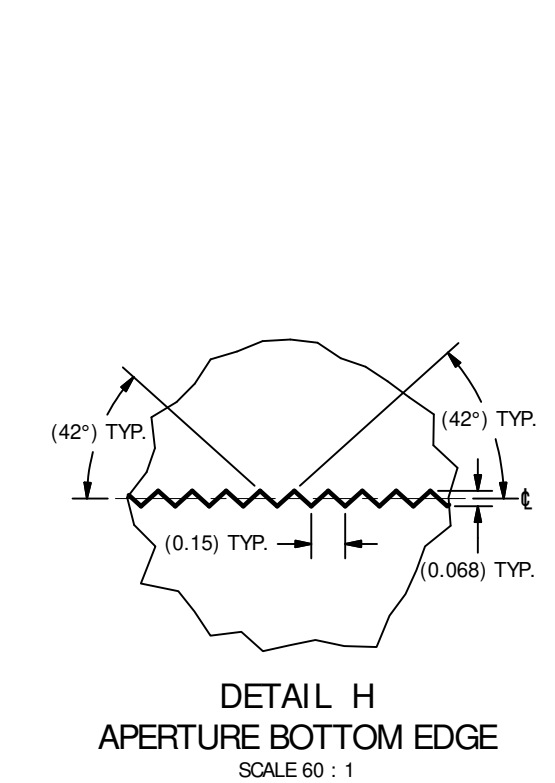

**VIEW J-J**  
BACK SIDE METALLIZATION  
(FROM SHEET 1)

## IMPORTANT NOTICE AND DISCLAIMER

TI PROVIDES TECHNICAL AND RELIABILITY DATA (INCLUDING DATASHEETS), DESIGN RESOURCES (INCLUDING REFERENCE DESIGNS), APPLICATION OR OTHER DESIGN ADVICE, WEB TOOLS, SAFETY INFORMATION, AND OTHER RESOURCES "AS IS" AND WITH ALL FAULTS, AND DISCLAIMS ALL WARRANTIES, EXPRESS AND IMPLIED, INCLUDING WITHOUT LIMITATION ANY IMPLIED WARRANTIES OF MERCHANTABILITY, FITNESS FOR A PARTICULAR PURPOSE OR NON-INFRINGEMENT OF THIRD PARTY INTELLECTUAL PROPERTY RIGHTS.

These resources are intended for skilled developers designing with TI products. You are solely responsible for (1) selecting the appropriate TI products for your application, (2) designing, validating and testing your application, and (3) ensuring your application meets applicable standards, and any other safety, security, or other requirements. These resources are subject to change without notice. TI grants you permission to use these resources only for development of an application that uses the TI products described in the resource. Other reproduction and display of these resources is prohibited. No license is granted to any other TI intellectual property right or to any third party intellectual property right. TI disclaims responsibility for, and you will fully indemnify TI and its representatives against, any claims, damages, costs, losses, and liabilities arising out of your use of these resources.

TI's products are provided subject to TI's Terms of Sale ([www.ti.com/legal/termsofsale.html](http://www.ti.com/legal/termsofsale.html)) or other applicable terms available either on [ti.com](http://ti.com) or provided in conjunction with such TI products. TI's provision of these resources does not expand or otherwise alter TI's applicable warranties or warranty disclaimers for TI products.

Mailing Address: Texas Instruments, Post Office Box 655303, Dallas, Texas 75265  
Copyright © 2019, Texas Instruments Incorporated