



FocusLCDs.com
LCDs MADE SIMPLE®

Ph. 480-503-4295 | NOPP@FocusLCD.com

TFT | CHARACTER | UWVD | FSC | SEGMENT | CUSTOM | REPLACEMENT

TFT Display Module

Part Number

E35KA-FW1000-N

Overview:

- 3.5-inch TFT: (54.46x82.94)
- 320(RGB)x480
- 16-Bit MCU Interface
- 3.3V (TYP)
- White LED back-light
- Transmissive/ Normally Black
- No Touch Panel
- 1000 NITS
- Controllers: ILI9488
- RoHS Compliant

Description

This is a color active matrix TFT (Thin Film Transistor) LCD (Liquid Crystal Display) that uses amorphous silicon TFT as a switching device. This model is composed of a transmissive type TFT-LCD Panel, driver IC, FPC and backlight unit. The resolution of the 3.5" TFT-LCD contains 320x480 pixels and can display up to 262K colors.

Features

Low Input Voltage: 3.3V (TYP)

Display Colors: 262K colors

TFT Interface: 16-bit MCU

General Information Items	Specification	Unit	Note
	Main Panel		
TFT Display Area (AA)	48.96(W) x 73.44(H) (3.5 inch)	mm	-
Driver Element	TFT active matrix	-	-
Display Colors	262K	colors	-
Display Resolution	320(RGB)x480	pixels	-
TFT Pixel Arrangement	RGB stripe	-	-
Viewing Angle	ALL	o'clock	-
TFT Controller IC	ILI9488	-	-
IC Package Type	COG	-	-
Display Mode	Transmissive/Normally Black	-	-
Interface	16-bit MCU	-	-
Power Supply Voltage	2.8-3.3	V	-
LCM Brightness	1000	cd/m ²	-
Backlight	White LED *10	PCS	-
Operating Temperature	-20~+70	°C	-
Storage Temperature	-30~+80	°C	-

Mechanical Information

Item		Min	Typ.	Max	Unit	Note
Module Size	Height (H)		82.94		mm	-
	Width (W)		54.46		mm	-
	Depth (D)		3.65		mm	-
Weight			TBD		g	-

1. Block Diagram

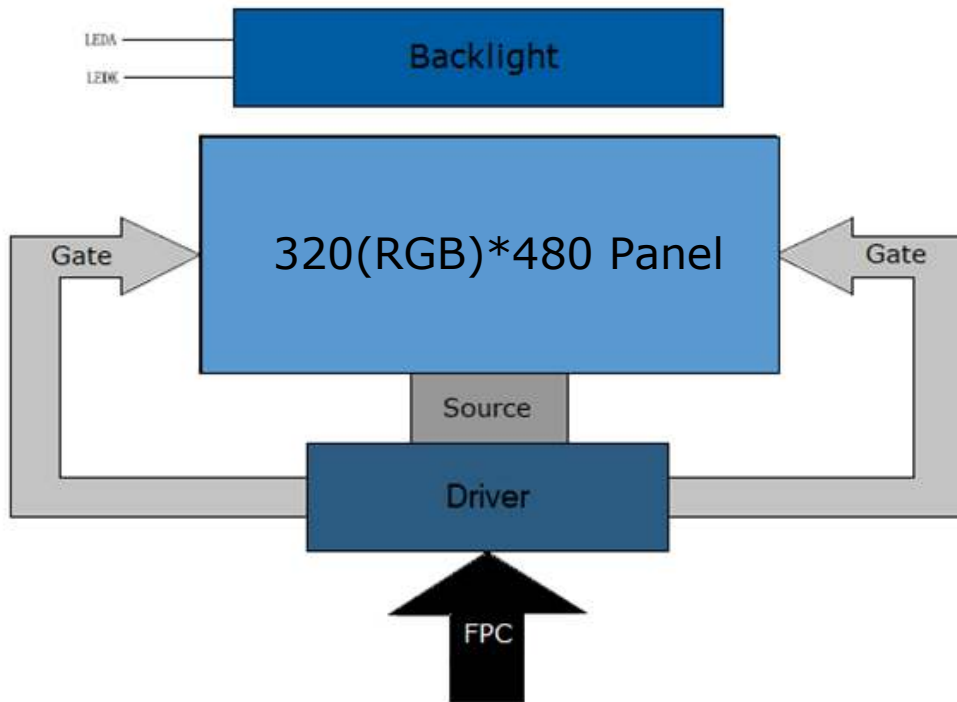

2. Outline Dimensions

RoHS



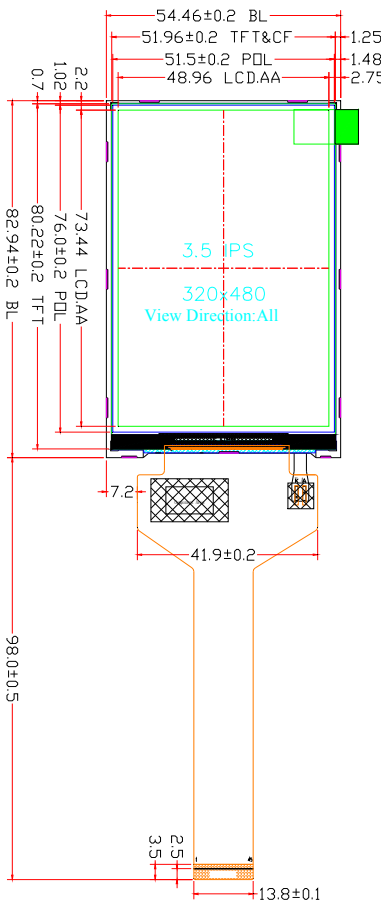

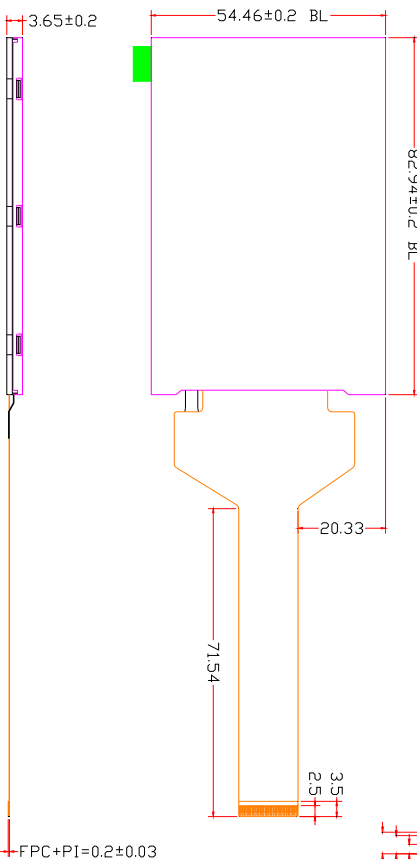

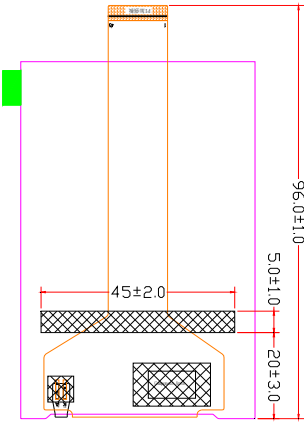

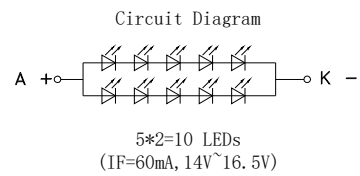

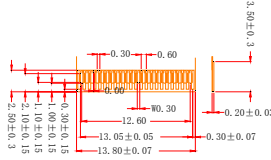

Circuit Diagram
5*2=10 LEDs
(IF=60mA, 14V~16.5V)



DETAIL A: 2:1

PIN	SYMBOL
1	GND
2	LED1
3	LED2
4	LED3
5	LED4
6	LED5
7	LEDA
8	GND
9	CS
10	RS
11	WR/SCL
12	RD
13	SDI
14	DB17(NC)
15	DB16(NC)
16	DB15
17	DB14
18	DB13
19	DB12
20	DB11
21	DB10
22	DB9
23	DB8
24	DB7
25	DB6
26	DB5
27	DB4
28	DB3
29	DB2
30	DB1
31	DB0
32	DE
33	PCLK
34	HSYNC
35	VSYNC
36	RESET
37	GND
38	IM2
39	IM1
40	IMO
41	IOVCC
42	VCC
43	VCC
44	FMARK
45	LCM_ID

Display Type	TFT/Normally Black/TRANSMISSIVE		
Display Resolution	DOTS: 320RGB*480		
Viewing Angle	ALL		
LCD Controller/Driver	ILI9488		
Logic Voltage	3.3V		
Operation Temperature	-20°C ~ 70°C		
Storage Temperature	-30°C ~ 80°C		
Backlight Spec.	White LED (5 dies in series 2 parallel I=60mA V=15.6V)		

					 FocusLCDs.com LCDs MADE SIMPLE®		
			DRAWN:			TITLE:	E35KA-FW1000-N
			CHECK:			DOC. NO.	
1.0	First	2019.02.21	APPROVE:			PART NO.	
REV.	DESCRIPTION	DATE			REV.	1.0	
					SHEET	1 OF 1	
					UNITS:	mm	

3. Input Terminal Pin Assignment

3.1 TFT

NO.	Symbol	Description	I/O
1	GND	System ground	P
2-6	LEDK	LED power supply -	P
7	LEDA	LED power supply +	P
8	GND	System ground	P
9	CS	Chip select input pin	I
10	RS	Register select	I
11	WR	Bus interface operation, write	I
12	RD	Bus interface operation, read	I
13	SDI	Serial data in/out	I/O
14-15	DB17-DB16	GND level when not used	I/O
16-31	DB15-DB0	16-bit interface: DB0-DB15 are used	I/O
32	DE	Data enable signal. Pin to GND when not in use.	I
33	PCLK	Dot clock signal. Pin to IOVCC when not used.	P
34	HSYNC	Line synchronizing signal. Pin to GND when not used.	I
35	VSYNC	Frame synchronizing signal. Pin to GND when not used.	I
36	RESET	Reset signal, RSX pin	I
37	GND	System ground	P
38-40	IM[2:0]	Interface select mode. IM[2:0]=010B	O
41	IOVCC	Power supply, 1.65-3.2V	P
42-43	VCC	Power supply, 2.5-3.2V	P
44	FMARK		O
45	LCM_ID	LCM ID	O

I: Input, O: Output, P: Power

4. LCD Optical Characteristics

4.1 Optical Specifications

Item	Symbol	Condition	Min	Typ.	Max	Unit	Note	
Contrast Ratio	CR	Normal Viewing Angle $\theta=0$	400	800	--	--	(2)	
Response Time	Rising		TR+TF	--	25	35	ms	(4)
	Falling							
Color Gamut	S(%)		--	72.8	--	%	(5)	
Transmittance	T		--	4.4	--	%	(3)	
Color Filter Chromaticity	White		W _X	0.27	0.31	0.35	--	(5)(6)
			W _Y	0.28	0.32	0.36		
	Red		R _X	--	--	--		
			R _Y	--	--	--		
	Green		G _X	--	--	--		
		G _Y	--	--	--			
	Blue	B _X	--	--	--			
		B _Y	--	--	--			
Viewing Angle	Hor.	Θ_L	80	--	--	degree	(1)(6)	
		Θ_R	80	--	--			
	Ver.	Θ_T	80	--	--			
		Θ_B	80	--	--			
Option View Direction	FREE						(1)	

4.2 Measuring Conditions

Measuring surrounding: dark room

Ambient temperature: 25±2°C

15 min. warm-up time

Optical Specification Reference Notes:

(1) Definition of Viewing Angle: The viewing angle is the angle at which the contrast ratio is greater than 10. The viewing angles are determined for the horizontal or 3,9 o'clock direction and the vertical or 6,12 o'clock direction with respect to the optical axis which is normal to the LCD surface.

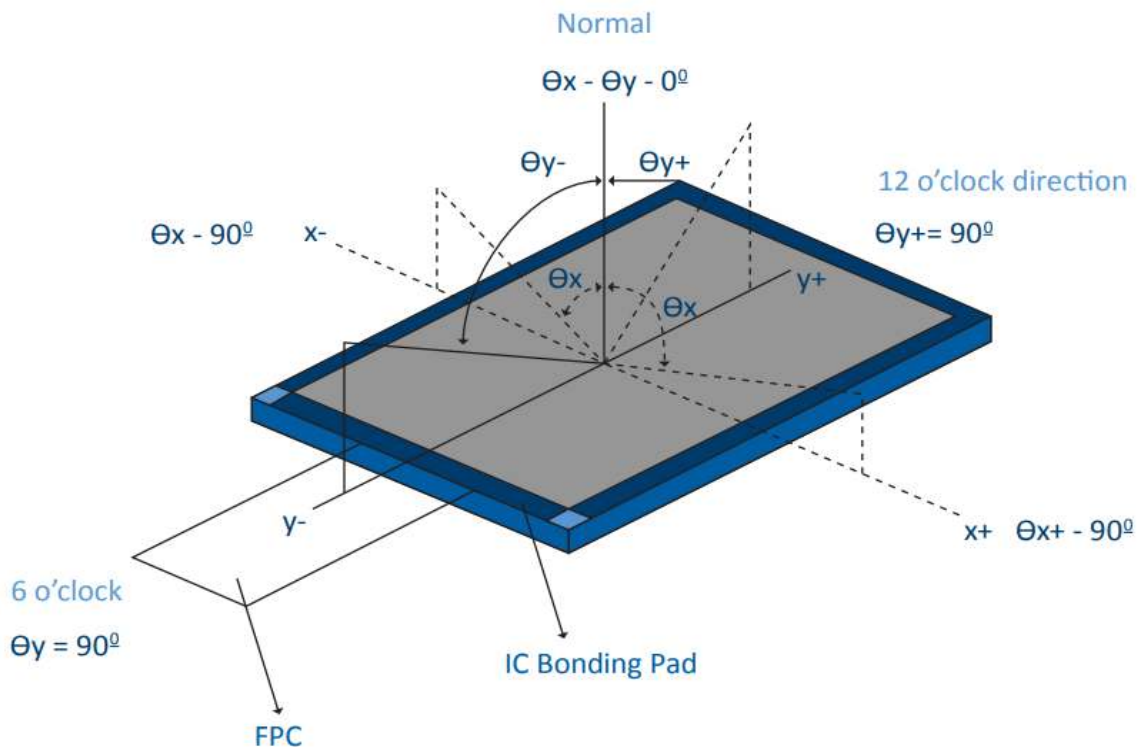
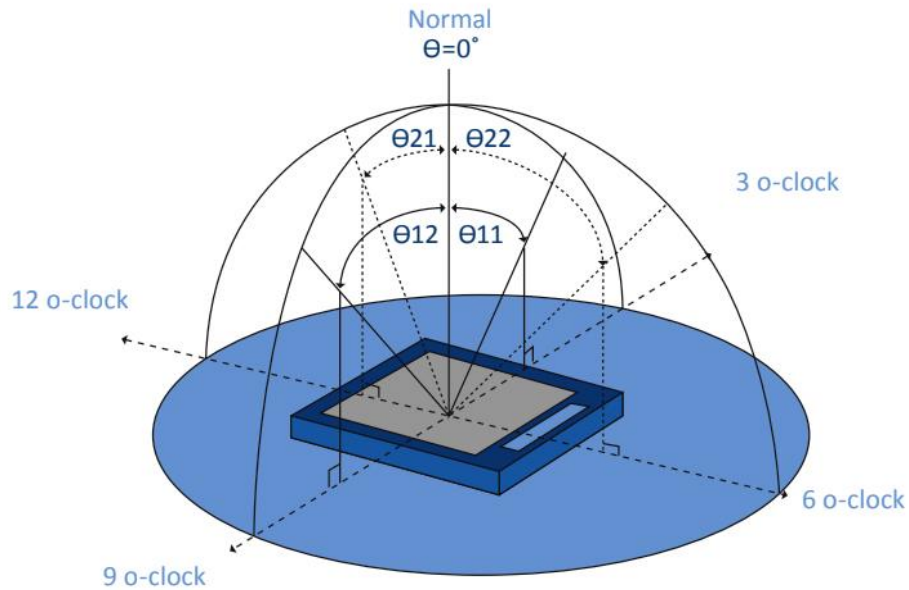

(2) Definition of Contrast Ratio (Cr): measured at the center point of panel. The contrast ratio (Cr) measured on a module, is the ratio between the luminance (Lw) in a full white area (R=G=B=1) and the luminance (Ld) in a dark area (R=G=B=0).

$$Cr = \frac{L_w}{L_d}$$

(3) Definition of transmittance (T%): The transmittance of the panel including the polarizers is measured with electrical driving.

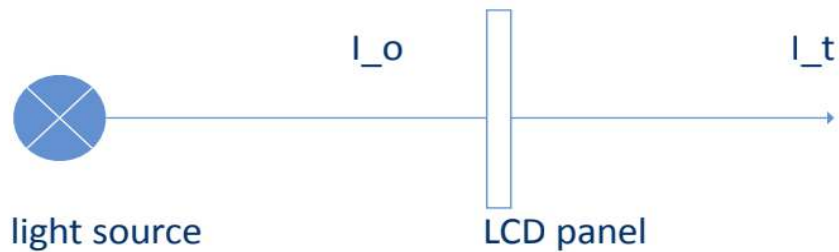

The transmittance is defined as:

$$Tr = \frac{I_t}{I_o} \times 100\%$$

I_o = the brightness of the light source.

I_t = the brightness after panel transmission

(4) Definition of Response Time (Tr, Tf): The rise time 'Tr' is defined as the time for luminance to change from 90% to 10% as a result of a change of the electrical condition. The fall time 'Tf' is defined as the time for luminance to change from 10% to 90% as a result of a change of the electrical condition.

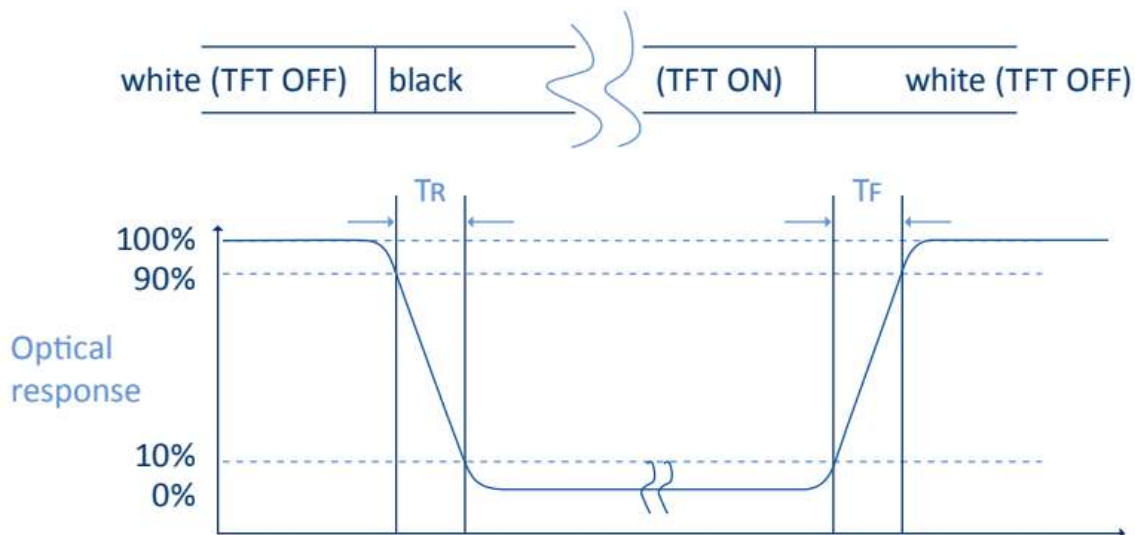

(5) Definition of Color Gamut: Measuring machine CFT-01. NTSC's Primaries: R(x,y,Y),G(x,y,Y), B(x,y,Y). FPM520 of Westar Display Technologies, INC., which utilized SR-3 for Chromaticity and BM-5A for other optical characteristics.

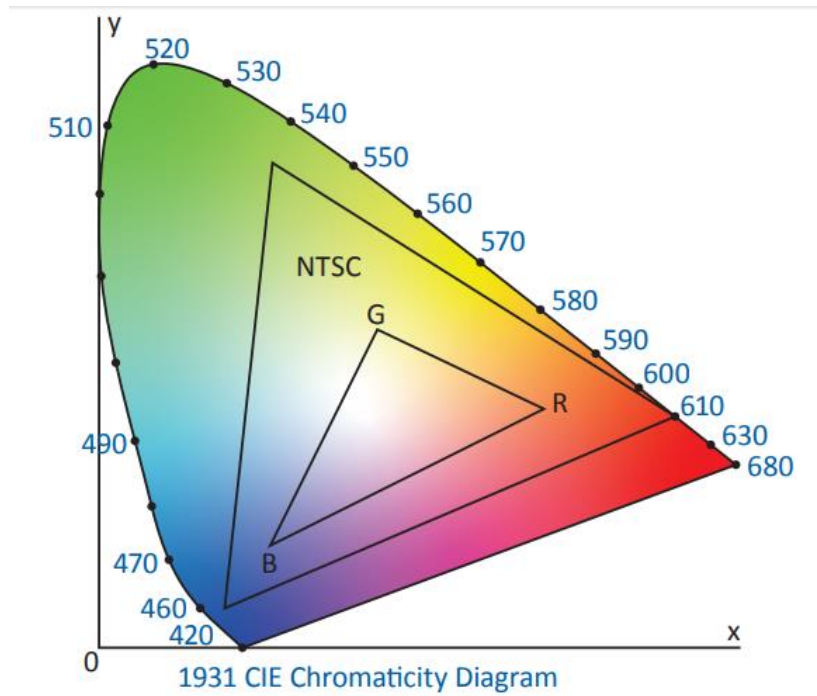
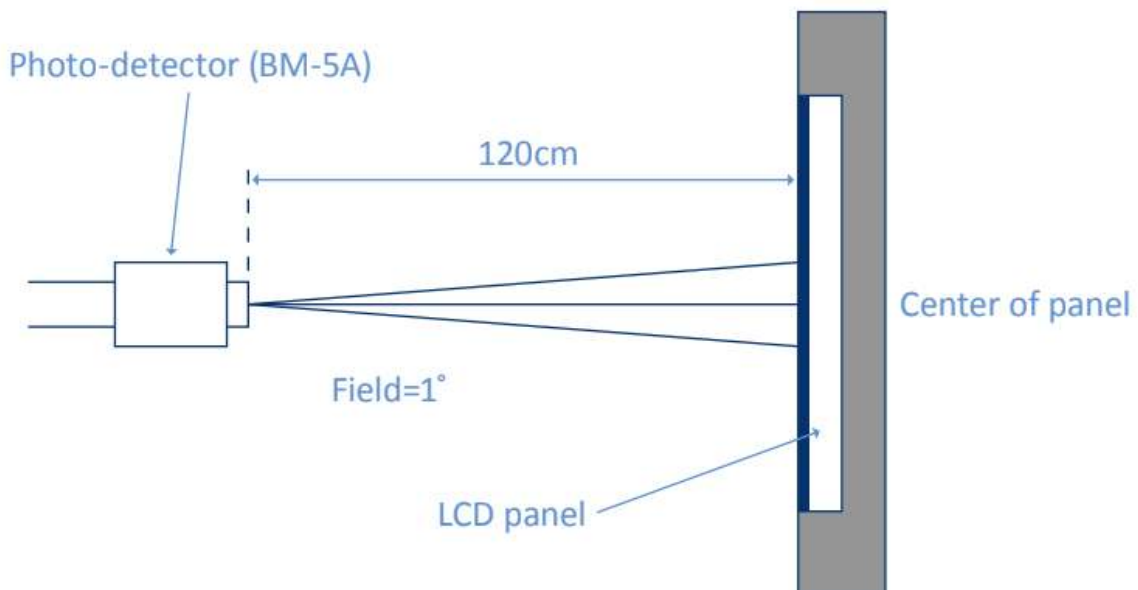

Fig. 1931 CIE chromacity diagram

$$\text{Color gamut: } S = \frac{\text{Area of RGB triangle}}{\text{Area of NTSC triangle}} \times 100\%$$

(6) Definition of Optical Measurement Setup:



(6) Optical Measurement Setup Continued:

The LCD module should be stabilized at a given temperature for 20 minutes to avoid abrupt temperature change during measuring. In order to stabilize the luminance, the measurement should be executed after lighting backlight for 20 minutes.

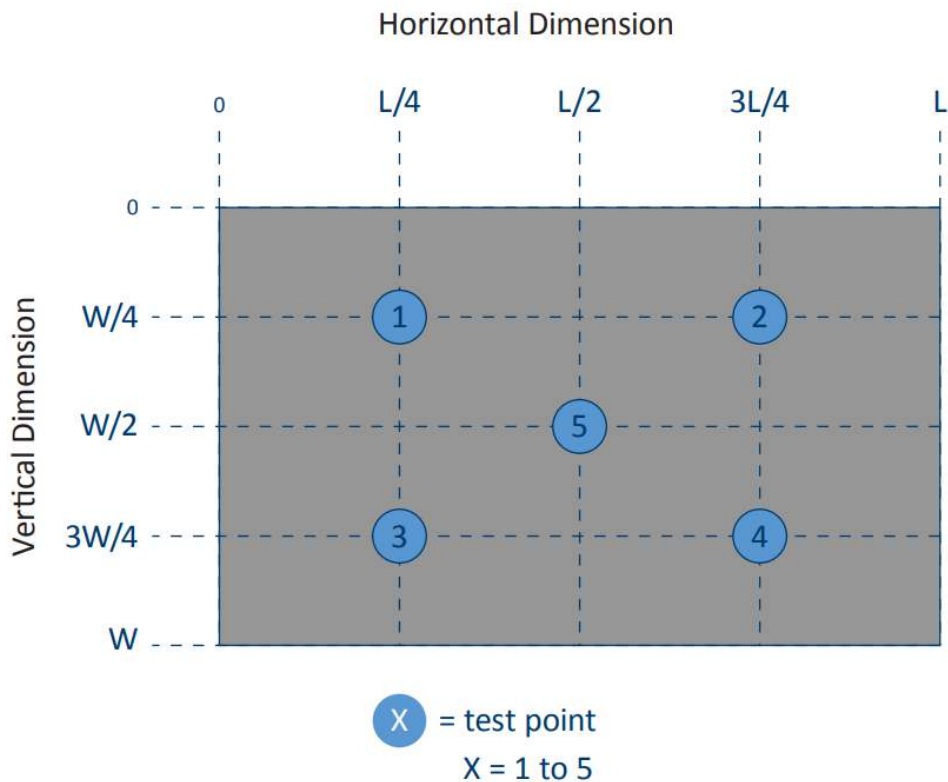
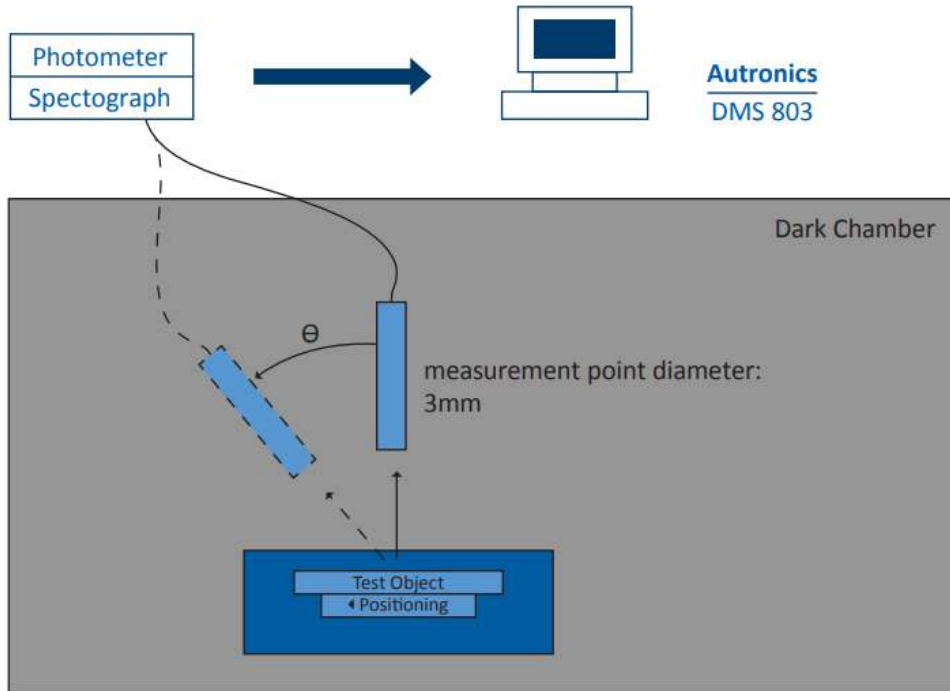

5. TFT Electrical Characteristics

5.1 Absolute Maximum Rating (Ta=25 °C, VSS=0V)

Characteristics	Symbol	Min	Max	Unit
Input Power Supply Voltage	VDD	-0.3	4.6	V
Analog Power Supply Voltage	AVCC	-0.3	4.6	V
Operating Temperature	TOP	-20	+70	°C
Storage Temperature	TST	-30	+80	°C
Operating Humidity	Hop	90	90	%(RH)

NOTE: If the absolute maximum rating of the above parameters is exceeded, even momentarily, the quality of the product may be degraded. Absolute maximum ratings specify the values which the product may be physically damaged if exceeded. Be sure to use the product within the range of the absolute maximum ratings.

5.2 DC Electrical Characteristics

Characteristics	Symbol	Min	Typ.	Max	Unit	Note
Supply Voltage	IOVCC	1.65	1.8	3.2	V	
Analog Supply Voltage	VCC	2.5	2.8	3.2	V	
Normal Mode Current Consumption	IDD	--	--	--	mA	
Level Input Voltage	VIH	0.7IOVDD	--	IOVDD	V	
	VIL	GND	--	0.3IOVDD	V	
Level Output Voltage	VOH	0.8IOVDD	--	IOVDD	V	
	VOL	GND	--	0.2IOVDD	V	

5.3 LED Backlight Characteristics

Item	Symbol	Min	Typ.	Max	Unit	Note
Forward Current	IF	--	60	--	mA	
Forward Voltage	VF	14	15	17-	V	
Average Brightness	IV	12000	--	--	cd/m2	Note 3
LED lifetime	Hr	50000	--	--	hour	Note1 & 2
Uniformity	AVg	80	--	--	%	Note 3

The back-light system is edge-lighting type with 10 chips White LED

Note 1: LED lifetime (Hr) can be defined as the time in which it continues to operate under the condition: Ta=25 ±3 °C, typical IL value indicated in the above table until the brightness becomes less than 50%.

Note 2: The “LED lifetime” is defined as the module brightness decrease to 50% original brightness at Ta=25°C and IL=60mA. The LED lifetime could be decreased if operating IL is larger than 60mA. The constant current driving method is suggested.

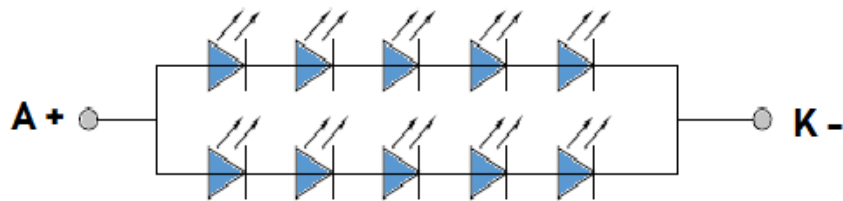

Backlight LED Circuit

Note 3: Luminance Uniformity of these 9 points is defined as below:

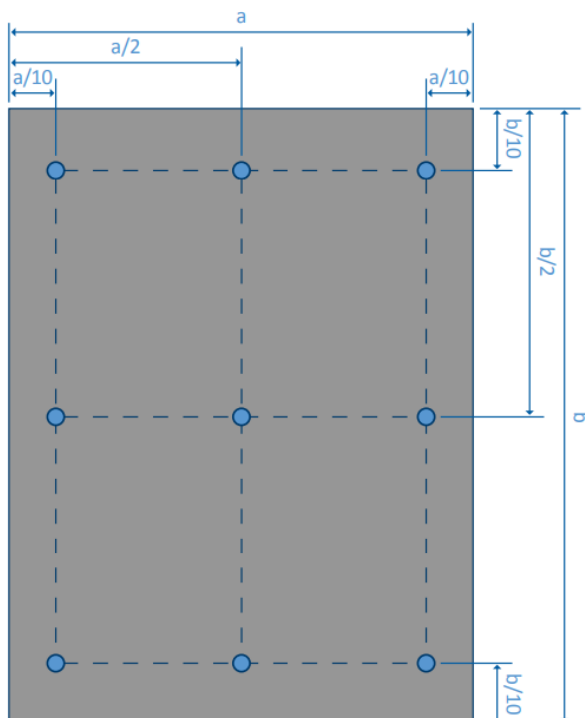

$$\text{Luminance} = \frac{\text{(Total Luminance of 9 points)}}{9}$$

$$\text{Uniformity} = \frac{\text{minimum luminance in 9 points(1-9)}}{\text{maximum luminance in 9 points(1-9)}}$$

6. AC Characteristics

6.1 16-Bit MCU Interface

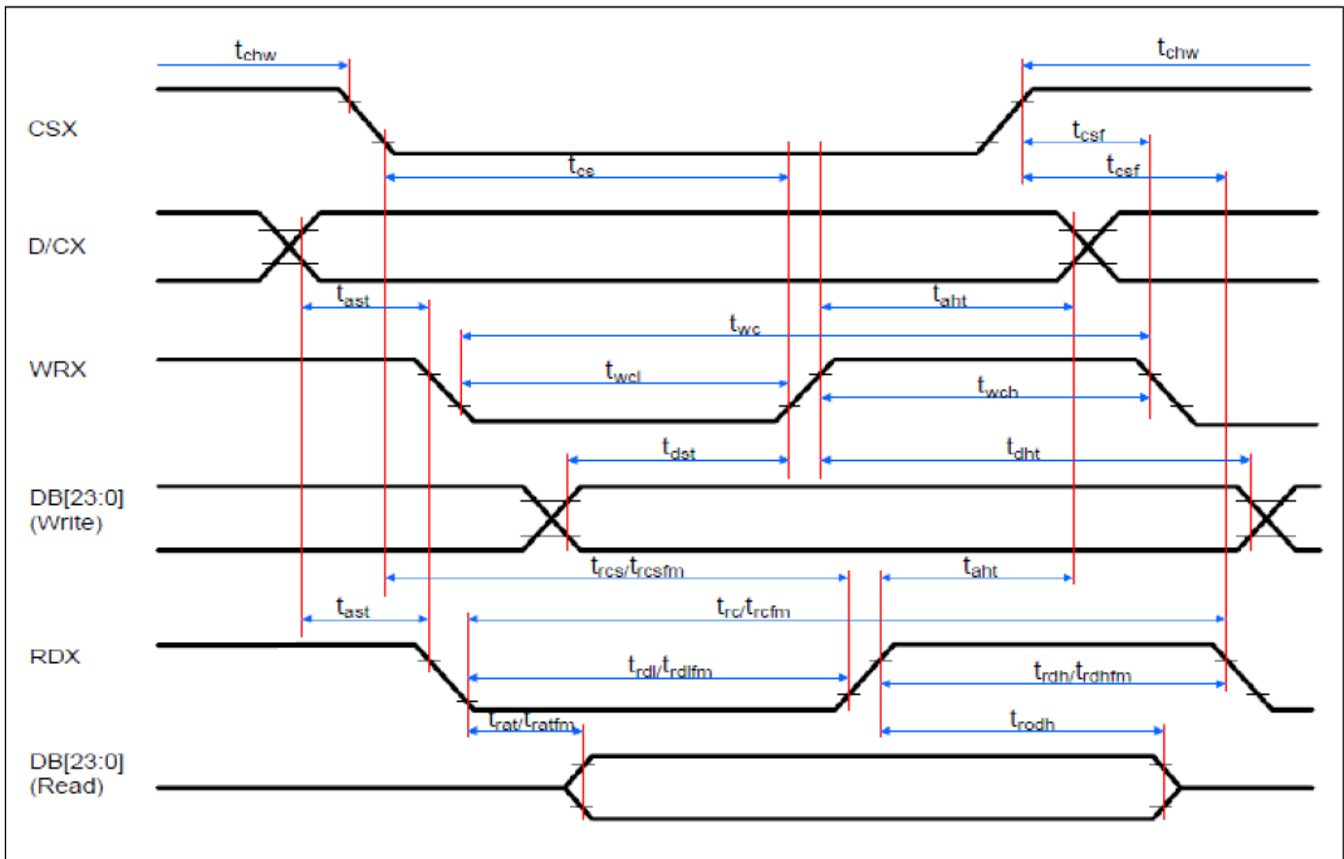

Figure 6.1: 3-line SPI Interface Timing Diagram

Parameter	Symbol	Parameter	Min	Max	Unit	Note
DCX	tast	Address setup time	0	-	ns	
	taht	Address hold time (write/read)	10	-	ns	
CSX	tcs	Chip select setup time (write)	10	-	ns	
	trcs	Chip select setup time (read)	45	-	ns	
	trcsfm	Chip select setup time (GRAM)	355	-	ns	
	tcsf	Chip select wait time (write/read)	10	-	ns	
WRX	twc	Write cycle (write)	50	-	ns	
	twc	Write cycle (write GRAM@SLPOUT)	47	-	ns	
	twc	Write cycle (write GRAM@SLPIN)	100	-	ns	
	twrh	Control pulse "H" duration	15	-	ns	
	twrl	Control pulse "L" duration	15	-	ns	
RDX	trc	Read cycle (read)	160	-	ns	
	trc	Read cycle (GRAM)	450	-	ns	
	trdh	Control pulse "H" duration	90	-	ns	
	trdl	Control pulse "L" duration (read)	35	-	ns	
	trdl	Control pulse "L" duration (GRAM)	345	-	ns	
DB[23:0]	tdst	Data setup time	10	-	ns	For max CL=30pF For min CL=8pF
	tdht	Data hold time	10	-	ns	
	trat	Read access time (read)	-	40	ns	
	trat	Read access time (GRAM)	-	340	ns	
	todh	Output disable time	20	80	ns	

Table 6.1: 3-line SPI Interface Timing Characteristics

6.2 Reset Timing

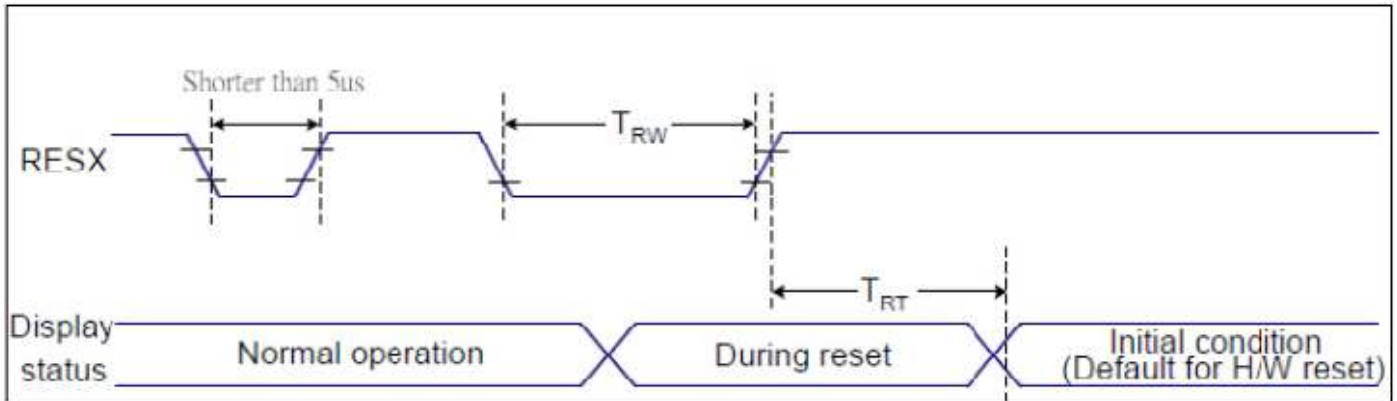

Figure 6.5: Reset Timing Diagram

Related Pins	Symbol	Parameter	Min	Max	Unit
RESX	TRW	Reset pulse duration	10	-	us
	TRT	Reset cancel	-	5 (Note 1,5)	ms
				120 (Note 1, 6, 7)	ms

Notes:

- The reset cancel includes also required time for loading ID bytes, VCOM setting and other settings from NVM (or similar device) to registers. This loading is done every time when there is HW reset cancel time (tRT) within 5ms after a rising edge of RESX.
- Spike due to an electrostatic discharge on RESX line does not because irregular system reset according to the table below:

RESX Pulse	Action
Shorter than 5us	Reset Rejected
Longer than 9us	Reset
Between 5us and 9 us	Reset starts

- During the resetting period, the display will be blanked (the display is entering blanking sequence, which maximum time is 120ms, when reset starts in Sleep Out mode. The display remains the blank state in Sleep in mode) and then return to Default condition for Hardware Reset.
- Spike Rejection also applies during a valid reset pulse as shown below:

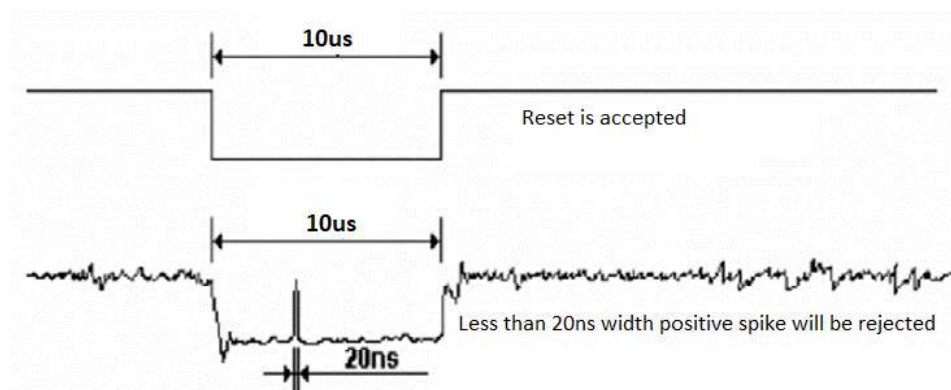

- When Reset applied during Sleep In Mode.
- When Reset applied during Sleep Out Mode.
- It is necessary to wait 5ms after releasing RESX before sending commands. Also Sleep Out command cannot be sent for 120ms.

7. Cautions and Handling Precautions

7.1 Handling and Operating the Module

1. When the module is assembled, it should be attached to the system firmly. Do not warp or twist the module during assembly work.
2. Protect the module from physical shock or any force. In addition to damage, this may cause improper operation or damage to the module and back-light unit.
3. Note that polarizer is very fragile and could be easily damaged. Do not press or scratch the surface.
4. Do not allow drops of water or chemicals to remain on the display surface. If you have the droplets for a long time, staining and discoloration may occur.
5. If the surface of the polarizer is dirty, clean it using some absorbent cotton or soft cloth.
6. The desirable cleaners are water, IPA (Isopropyl Alcohol) or Hexane. Do not use ketene type materials (ex. Acetone), Ethyl alcohol, Toluene, Ethyl acid or Methyl chloride. It might permanent damage to the polarizer due to chemical reaction.
7. If the liquid crystal material leaks from the panel, it should be kept away from the eyes or mouth. In case of contact with hands, legs, or clothes, it must be washed away thoroughly with soap.
8. Protect the module from static; it may cause damage to the CMOS ICs.
9. Use fingerstalls with soft gloves in order to keep display clean during the incoming inspection and assembly process.
10. Do not disassemble the module.
11. Protection film for polarizer on the module shall be slowly peeled off just before use so that the electrostatic charge can be minimized.
12. Pins of I/F connector shall not be touched directly with bare hands.
13. Do not connect, disconnect the module in the "Power ON" condition.
14. Power supply should always be turned on/off by the item Power On Sequence & Power Off Sequence.

7.2 Storage and Transportation.

1. Do not leave the panel in high temperature, and high humidity for a long time. It is highly recommended to store the module with temperature from 0 to 35 °C and relative humidity of less than 70%
2. Do not store the TFT-LCD module in direct sunlight.
3. The module shall be stored in a dark place. When storing the modules for a long time, be sure to adopt effective measures for protecting the modules from strong ultraviolet radiation, sunlight, or fluorescent light.
4. It is recommended that the modules should be stored under a condition where no condensation is allowed. Formation of dewdrops may cause an abnormal operation or a failure of the module. In particular, the greatest possible care should be taken to prevent any module from being operated where condensation has occurred inside.
5. This panel has its circuitry FPC on the bottom side and should be handled carefully in order not to be stressed.