

2p to 6p with wedge,
above 7p without wedge
(including 7p)

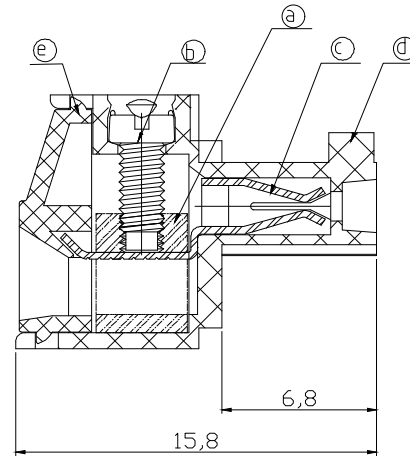
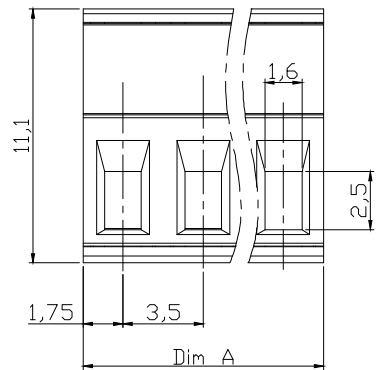
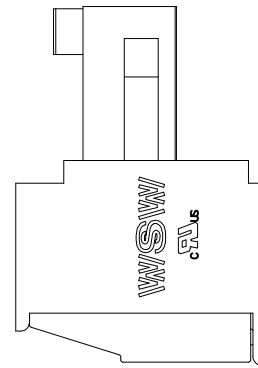
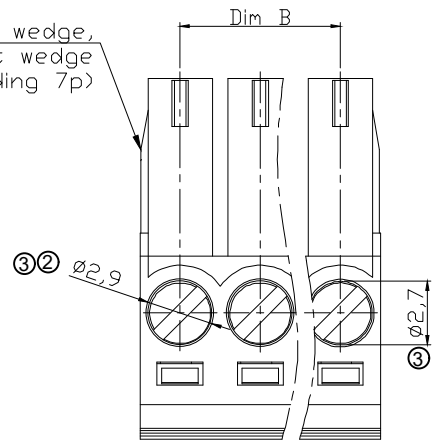

Material

- Item ① Clamp: Brass(CuZn) Ni plated
- Item ② Terminal screw: Steel Zinc plating"-slot type
- Item ③ Female contact: PhBz, Tin plated
- Item ④ Terminal(housing): PA66 (UL94V-0) Green(RAL356C)
- Item ⑤ Terminal cover: PA66 (UL94V-0) Green(RAL356C)

Electrical cULus

- Voltage rating: 300VAC
- Current rating: 10A
- Wire range: 1.5mm²
- Solid wire(AWG): 16-28
- Stranded wire(AWG): 6-28
- Torque: 3lb-In
- Screw: M2
- ③ With strip length: 6-7mm
- Withstanding Voltage: 1.6KV
- Operating temperature: -40°C to +115°C
- Safety Approval:

⑥ Packaging: PE Bag

DIMENSION

A	Nx3.5
B	(N-1)x3.5

N=Number of poles

⑤ Poles	Dim A&B Tol.
2p-6p	±0.15
7p-12p	±0.25
13p-18p	±0.30
19p-24p	±0.40

RoHS compliant
Unit: mm



Scale	Free	⑥	Modification	Date	Name	Date	Name	Customer-No.
TOLERANCE		⑤	Add the WSW Logo&UL mark	10.11.2019	Winnie	10.12.2009	Dean	ASSMANN WSW-No. A-TB350-TJxxU
X.	±0.50	④	Add packaging type	07.08.2018	Xavier	13.04.2022	Daniel	
X.X	±0.30	③	Update	05.01.2018	Tom			Drawing-No. ASS 3822 CO
X.XX	±0.20	②	Update to new drawing and add UL	14.04.2016	Amy			
DIM	TOL	①	Drawn	10.12.2009	Dean			Replace
X.°	±1°	Id.						
Angle	TOL							Sheet



Customer-No.	
ASSMANN WSW-No. A-TB350-TJxxU	
Drawing-No. ASS 3822 CO	
Replace	Sheet

