

FEATURES

- Integrated programmable clock divider and 1:2 fanout buffer
- Guaranteed AC performance over temperature and voltage:
 - > 2.0GHz f_{MAX}
 - < 200ps t_r/t_f
 - < 15ps within device skew
- Low jitter design:
 - < 10ps_{PP} total jitter
 - < 1ps_{RMS} cycle-to-cycle jitter
- Unique input termination and V_T Pin for DC-coupled and AC-coupled Inputs; CML, PECL, LVDS and HSTL
- LVDS compatible outputs
- TTL/CMOS inputs for select and reset
- Parallel programming capability
- Programmable divider ratios of 1, 2, 4, 8 and 16
- Low voltage operation 2.5V
- Output disable function
- -40°C to 85°C temperature range
- Available in 16-pin (3mm x 3mm) MLF® package

APPLICATIONS

- SONET/SDH line cards
- Transponders
- High-end, multiprocessor servers

FUNCTIONAL BLOCK DIAGRAM

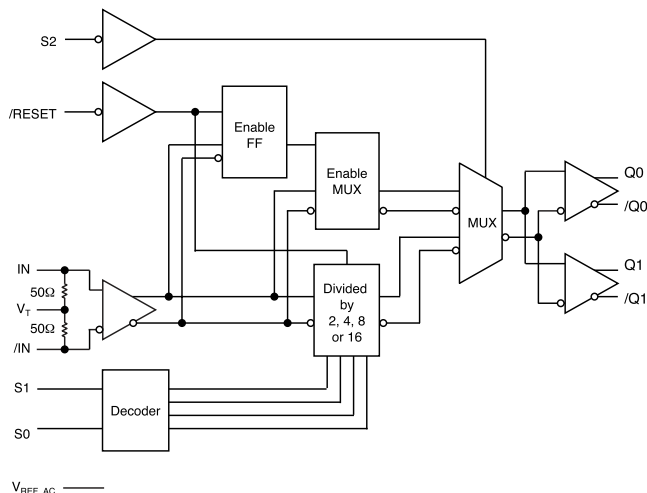

DESCRIPTION

This low-skew, low-jitter device is capable of accepting a high-speed (e.g., 622MHz or higher) CML, LVPECL, LVDS or HSTL clock input signal and dividing down the frequency using a programmable divider to create a lower speed version of the input clock. Available divider ratios are 2, 4, 8 and 16, or straight pass-through.

The differential input buffer has a unique internal termination design that allows access to the termination network through a V_T pin. This feature allows the device to easily interface to different logic standards. A V_{REF-AC} reference is included for AC-coupled applications.

The /RESET input asynchronously resets the divider. In the pass-through function (divide by 1) the /RESET synchronously enables or disables the outputs on the next falling edge of IN (rising edge of /IN).

TYPICAL PERFORMANCE

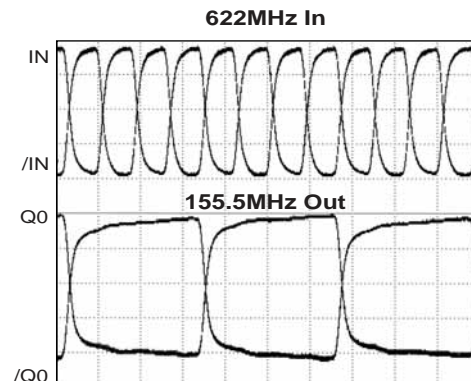
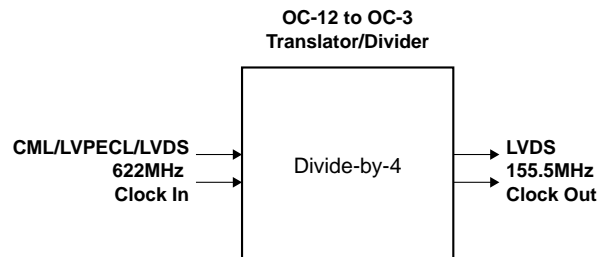

PACKAGE ORDERING INFORMATION

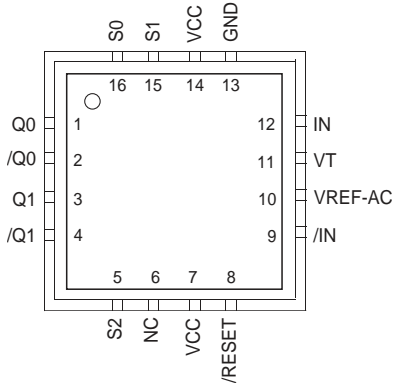

16-Pin MLF® (MLF-16)

Ordering Information(1)

Part Number	Package Type	Operating Range	Package Marking	Lead Finish
SY89875UMI	MLF-16	Industrial	875U	Sn-Pb
SY89875UMITR ⁽²⁾	MLF-16	Industrial	875U	Sn-Pb
SY89875UMG ⁽³⁾	MLF-16	Industrial	875U with Pb-Free bar line indicator	NiPdAu Pb-Free
SY89875UMGTR ^(2, 3)	MLF-16	Industrial	875U with Pb-Free bar line indicator	NiPdAu Pb-Free

Notes:

1. Contact factory for die availability. Dice are guaranteed at $T_A = 25^\circ\text{C}$, DC Electricals only.
2. Tape and Reel.
3. Pb-Free package is recommended for new designs.

PIN DESCRIPTION

Pin Number	Pin Name	Pin Function
12, 9	IN, /IN	Differential Input: Internal 50 Ω termination resistors to V_T input. Flexible input accepts any differential input. See “Input Interface Applications” section.
1, 2, 3, 4	Q0, /Q0 Q1, /Q1	Differential Buffered LVDS Outputs: Divided by 1, 2, 4, 8 or 16. See “Truth Table.” Unused output pairs must be terminated with 100 Ω across the different pair.
16, 15, 5	S0, S1, S2	Select Pins: See “Truth Table.” LVTTTL/CMOS logic levels. Internal 25k Ω pull-up resistor. Logic HIGH if left unconnected (divided by 16 mode.) Input threshold is $V_{CC}/2$.
6	NC	No Connect.
8	/RESET, /DISABLE	LVTTTL/CMOS Logic Levels: Internal 25k Ω pull-up resistor. Logic HIGH if left unconnected. Apply LOW to reset the divider (divided by 2, 4, 8 or 16 mode). Also acts as a disable/enable function. The reset and disable function occurs on the next high-to-low clock input transition. Input threshold is $V_{CC}/2$.
10	VREF-AC	Reference Voltage: Equal to $V_{CC}-1.4\text{V}$ (approx.). Used for AC-coupled applications only. Decouple the V_{REF-AC} pin with a 0.01 μF capacitor. See “Input Interface Applications” section.
11	VT	Termination Center-Tap: For CML or LVDS inputs, leave this pin floating. Otherwise, See Figures 4a to 4f, “Input Interface Applications” section.
7, 14	VCC	Positive Power Supply: Bypass with 0.1 μF //0.01 μF low ESR capacitor.
13	GND Exposed	Ground. Exposed pad must be connected to the same potential as the GND pin.

TRUTH TABLE

/RESET ⁽¹⁾	S2	S1	S0	Outputs
1	0	X	X	Reference Clock (pass through)
1	1	0	0	Reference Clock $\div 2$
1	1	0	1	Reference Clock $\div 4$
1	1	1	0	Reference Clock $\div 8$
1	1	1	1	Reference Clock $\div 16$
0 ⁽¹⁾	X	X	X	Q = LOW, /Q = HIGH Clock Disable

Note 1. Reset/Disable function is asserted on the next clock input (IN, /IN) high-to-low transition.

Absolute Maximum Ratings(Note 1)

Supply Voltage (V_{CC}) -0.5V to +4.0V
 Input Voltage (V_{IN}) -0.5V to $V_{CC}+0.3$
 ECL Output Current (I_{OUT})
 Continuous 50mA
 Surge 100mA
 Input Current I_N , $/I_N$ (I_{IN}) ± 50 mA
 V_T Current (I_{VT}) ± 100 mA
 V_{REF-AC} Sink/Source Current ($I_{VREF-AC}$), **Note 3** ± 2 mA
 Lead Temperature (soldering 20 sec.) 260°C
 Storage Temperature (T_S) -65°C to +150°C

Operating Ratings(Note 2)

Supply Voltage (V_{CC}) +2.5V $\pm 5\%$
 Ambient Temperature (T_A) -40°C to +85°C
 Package Thermal Resistance
 MLF® (θ_{JA})
 Still-Air 60°C/W
 500lfpm 54°C/W
 MLF® (ψ_{JB}), **Note 4**
 Junction-to-Board 32°C/W

- Note 1.** Permanent device damage may occur if absolute maximum ratings are exceeded. This is a stress rating only and functional operation is not implied at conditions other than those detailed in the operational sections of this data sheet. Exposure to absolute maximum rating conditions for extended periods may affect device reliability.
- Note 2.** The data sheet limits are not guaranteed if the device is operated beyond the operating ratings.
- Note 3.** Due to the limited drive capability use for input of the same package only.
- Note 4.** Junction-to-board resistance assumes exposed pad is soldered (or equivalent) to the device’s most negative potential on the pcb.

DC ELECTRICAL CHARACTERISTICS(Notes 1, 2)

$T_A = -40^\circ\text{C}$ to $+85^\circ\text{C}$; Unless otherwise stated.

Symbol	Parameter	Condition	Min	Typ	Max	Units
V_{CC}	Power Supply		2.375		2.625	V
I_{CC}	Power Supply Current	No load, max. V_{CC}		70	95	mA
R_{IN}	Differential Input Resistance (IN-to-/IN)		90	100	110	Ω
V_{IH}	Input High Voltage (IN, /IN)	Note 3	0.1	–	$V_{CC}+0.3$	V
V_{IL}	Input Low Voltage (IN, /IN)	Note 3	-0.3	–	$V_{IH}-0.1$	V
V_{IN}	Input Voltage Swing	Note 4	0.1	–	V_{CC}	V
V_{DIFF_IN}	Differential Input Voltage Swing	Note 5	0.2	–	–	V
$ I_{IN} $	Input Current (IN, /IN)	Note 3	–	–	45	mA
V_{REF-AC}	Reference Voltage	Note 6	$V_{CC}-1.525$	$V_{CC}-1.425$	$V_{CC}-1.325$	V

- Note 1.** The circuit is designed to meet the DC specifications shown in the above table after thermal equilibrium has been established.
- Note 2.** Specification for packaged product only.
- Note 3.** Due to the internal termination (see Figure 2a) the input current depends on the applied voltages at IN, /IN and V_T inputs. Do not apply a combination of voltages that causes the input current to exceed the maximum limit!
- Note 4.** See “Timing Diagram” for V_{IN} definition. V_{IN} (Max) is specified when V_T is floating.
- Note 5.** See “Typical Operating Characteristics” section for V_{DIFF} definition.
- Note 6.** Operating using V_{IN} is limited to AC-coupled PECL or CML applications only. Connect directly to V_T pin.

LVDS DC ELECTRICAL CHARACTERISTICS(Notes 1, 2)

$V_{CC} = 2.5V \pm 5\%$; $T_A = -40^\circ C$ to $+85^\circ C$; Unless otherwise stated.

Symbol	Parameter	Condition	Min	Typ	Max	Units
V_{OUT}	Output Voltage Swing	Note 3, 4	250	350	400	mV
V_{OH}	Output High Voltage	Note 3			1.475	V
V_{OL}	Output Low Voltage	Note 3	0.925			V
V_{OCM}	Output Common Mode Voltage	Note 4	1.125		1.375	V
ΔV_{OCM}	Change in Common Mode Voltage		-50		50	mV

Note 1. The circuit is designed to meet the DC specifications shown in the above table after thermal equilibrium has been established.

Note 2. Specification for packaged product only.

Note 3. Measured as per Figure 2a, 100 μ across Q and /Q outputs.

Note 4. Measured as per Figure 2b.

LVTTTL/CMOS DC ELECTRICAL CHARACTERISTICS(Notes 1, 2)

$V_{CC} = 2.5V \pm 5\%$; $T_A = -40^\circ C$ to $+85^\circ C$; Unless otherwise stated.

Symbol	Parameter	Condition	Min	Typ	Max	Units
V_{IH}	Input HIGH Voltage		2.0			V
V_{IL}	Input LOW Voltage				0.8	V
I_{IH}	Input HIGH Current		-125		20	μA
I_{IL}	Input LOW Current				-300	μA

Note 1. The circuit is designed to meet the DC specifications shown in the above table after thermal equilibrium has been established.

Note 2. Specification for packaged product only.

AC ELECTRICAL CHARACTERISTICS(Notes 1, 2)

$V_{CC} = 2.5V \pm 5\%$; $T_A = -40^{\circ}C$ to $+85^{\circ}C$; Unless otherwise stated.

Symbol	Parameter	Condition	Min	Typ	Max	Units
f_{MAX}	Maximum Input Frequency	Output Swing $\geq 200mV$	2.0	2.5		GHz
t_{PD}	Differential Propagation Delay IN to Q	Input Swing $< 400mV$	590	690	870	ps
		Input Swing $\geq 400mV$	540	690	820	ps
t_{SKEW}	Within-Device Skew (diff.)	Note 3		5	15	ps
	Part-to-Part Skew (diff.)	Note 3			280	ps
t_{RR}	Reset Recovery Time	Note 4	600			ps
t_{JITTER}	Cycle-to-Cycle Jitter	Note 5			1	ps _{RMS}
	Total Jitter	Note 6			10	ps _{PP}
t_r, t_f	Rise/Fall Time (20% to 80%)		70	120	200	ps

Note 1. Measured with 400mV input signal, 50% duty cycle, all outputs loaded with 100 Ω across each output pair, unless otherwise stated.

Note 2. Specification for packaged product only.

Note 3. Skew is measured between outputs under identical transitions.

Note 4. See "Timing Diagram."

Note 5. Cycle-to-cycle jitter definition: the variation in period between adjacent cycles over a random sample of adjacent cycle pairs. $T_{jitter_cc} = T_n - T_{n+1}$, where T is the time between rising edges of the output signal.

Note 6. Total jitter definition: with an ideal clock input of frequency - f_{MAX} , no more than one output edge in 10^{12} output edges will deviate by more than the specified peak-to-peak jitter value.

TIMING DIAGRAM

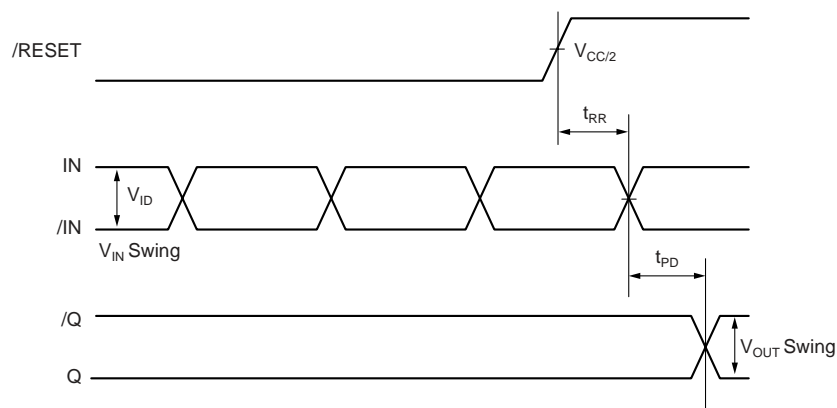

TYPICAL OPERATING CHARACTERISTICS

$V_{CC} = 2.5V$, $T_A = 25^\circ C$, unless otherwise stated.

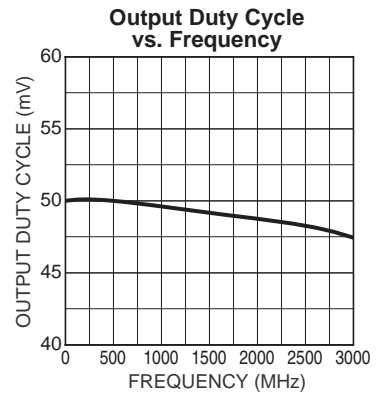
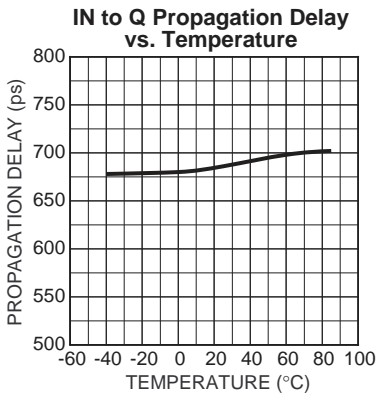
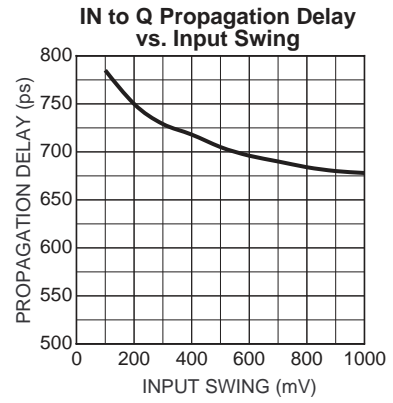
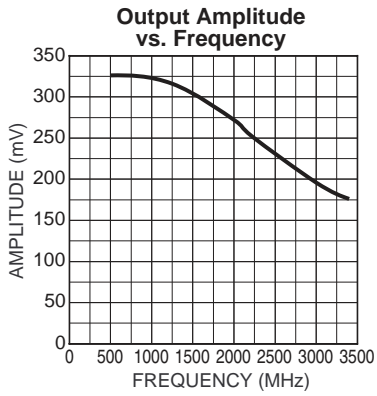

TYPICAL OPERATING CHARACTERISTICS (Continued)

$V_{CC} = 2.5V$, $T_A = 25^\circ C$, unless otherwise stated.

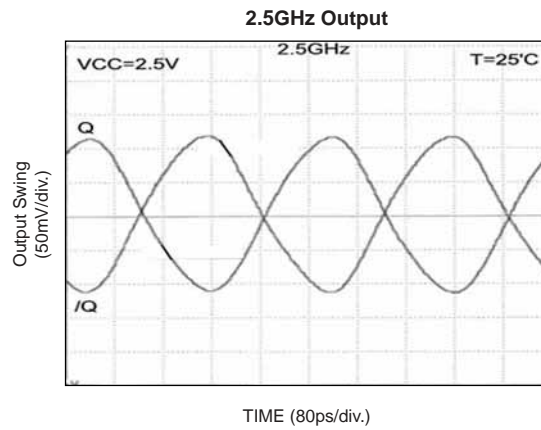
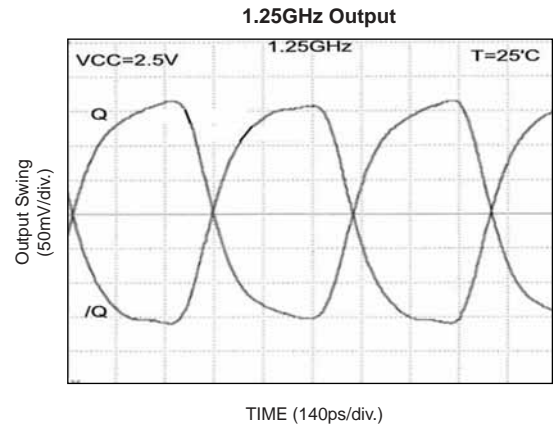
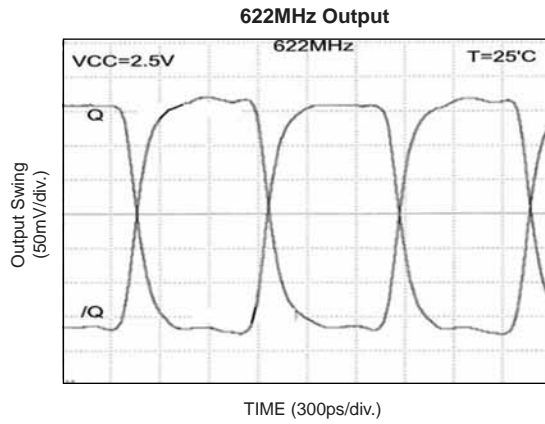

DEFINITION OF SINGLE-ENDED AND DIFFERENTIAL SWINGS

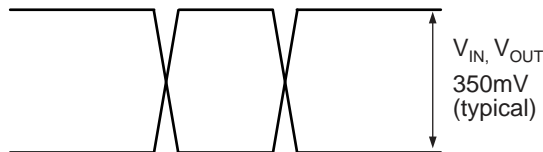

Figure 1a. Single-Ended Swing

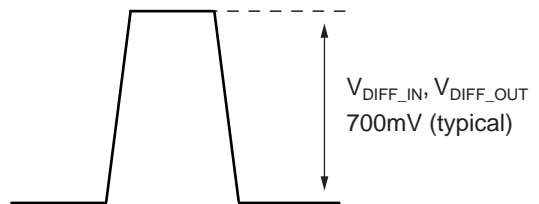

Figure 1b. Differential Swing

INPUT INTERFACE APPLICATIONS

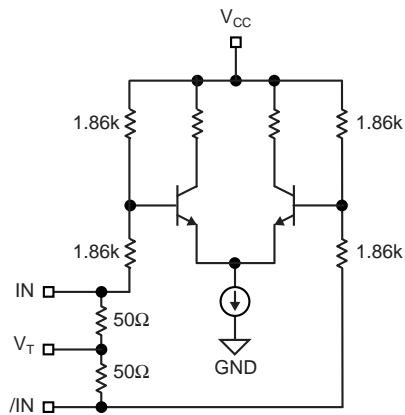

Figure 2a. Simplified Differential Input Buffer

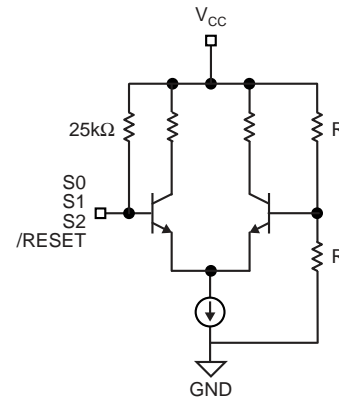

Figure 2b. Simplified TTL/CMOS Input Buffer

LVDS OUTPUTS

LVDS (Low Voltage Differential Swing) specifies a small swing of 350mV typical, on a nominal 1.25V common mode above ground. The common mode voltage has tight limits

to permit large variations in ground between an LVDS driver and receiver. Also, change in common mode voltage, as a function of data input, is also kept tight, to keep EMI low.

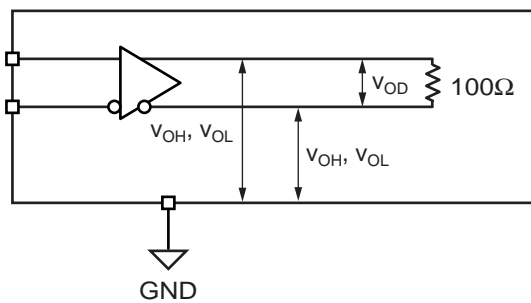

Figure 3a. LVDS Differential Measurement

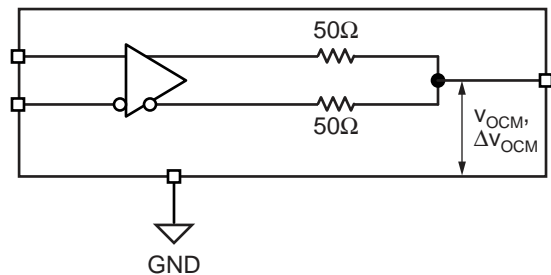

Figure 3b. LVDS Common Mode Measurement

INPUT INTERFACE APPLICATIONS

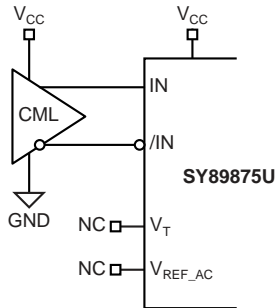

Figure 4a. DC-Coupled CML Input Interface

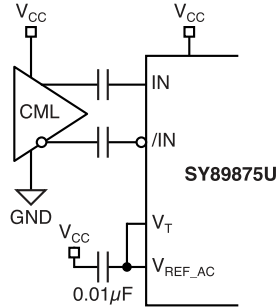

Figure 4b. AC-Coupled CML Input Interface

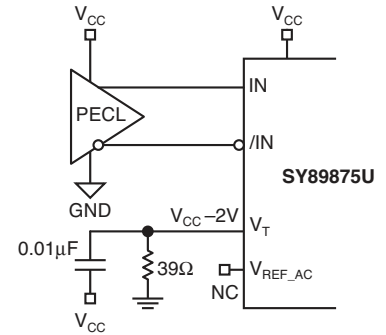

Figure 4c. DC-Coupled PECL Input Interface

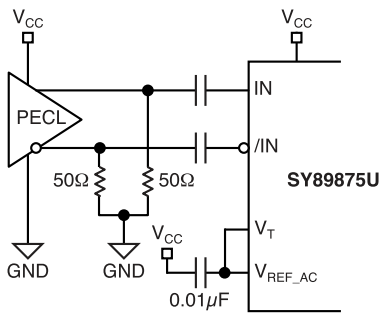

Figure 4d. AC-Coupled CML Input Interface

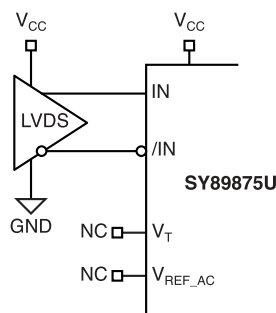

Figure 4e. LVDS Input Interface

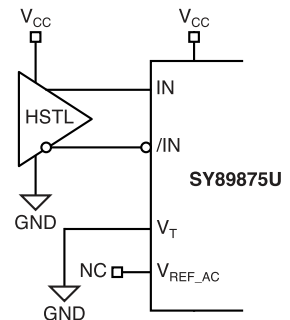
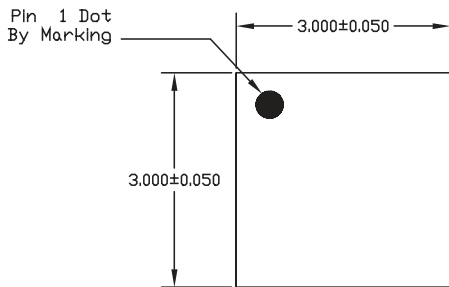

Figure 4f. HSTL Input Interface

RELATED PRODUCT AND SUPPORT DOCUMENTATION

Part Number	Function	Data Sheet Link
SY89872U	2.5V, 2.5GHz Any Diff. In-to-LVDS Programmable Clock Divider/Fanout Buffer w/ Internal Termination	http://www.micrel.com/product-info/products/sy89872u.shtml
	MLF® Application Note	http://www.amkor.com/products/notes_papers/mlf_appnote_0902.pdf
HBW Solutions	New Products and Applications	http://www.micrel.com/product-info/products/solutions.shtml

16-PIN MicroLeadFrame® (MLF-16)



TOP VIEW

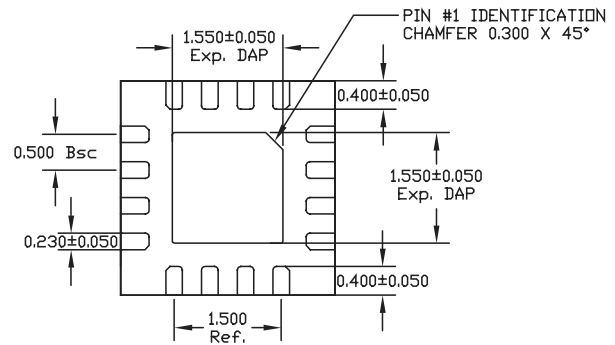

BOTTOM VIEW

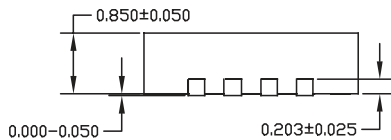

SIDE VIEW

NOTE:

1. ALL DIMENSIONS ARE IN MILLIMETERS.
2. MAX. PACKAGE WARPAGE IS 0.05 mm.
3. MAXIMUM ALLOWABLE BURRS IS 0.076 mm IN ALL DIRECTIONS.
4. PIN #1 ID ON TOP WILL BE LASER/INK MARKED.

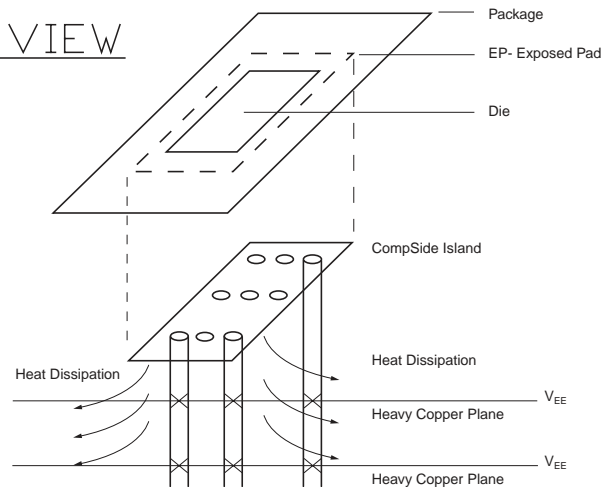

**PCB Thermal Consideration for 16-Pin MLF® Package
(Always solder, or equivalent, the exposed pad to the PCB)**

Package Notes:

- Note 1.** Package meets Level 2 moisture sensitivity classification, and are shipped in dry-pack form.
- Note 2.** Exposed pads must be soldered to a ground for proper thermal management.

MICREL, INC. 2180 FORTUNE DRIVE SAN JOSE, CA 95131 USA

TEL + 1 (408) 944-0800 FAX + 1 (408) 474-1000 WEB <http://www.micrel.com>

The information furnished by Micrel in this datasheet is believed to be accurate and reliable. However, no responsibility is assumed by Micrel for its use. Micrel reserves the right to change circuitry and specifications at any time without notification to the customer.

Micrel Products are not designed or authorized for use as components in life support appliances, devices or systems where malfunction of a product can reasonably be expected to result in personal injury. Life support devices or systems are devices or systems that (a) are intended for surgical implant into the body or (b) support or sustain life, and whose failure to perform can be reasonably expected to result in a significant injury to the user. A Purchaser's use or sale of Micrel Products for use in life support appliances, devices or systems is at Purchaser's own risk and Purchaser agrees to fully indemnify Micrel for any damages resulting from such use or sale.