

THIS DRAWING IS UNPUBLISHED. RELEASED FOR PUBLICATION
 © COPYRIGHT BY TYCO ELECTRONICS CORPORATION. ALL RIGHTS RESERVED.

LOC	DIST	REVISIONS					
GE	00	P	LTR	DESCRIPTION	DATE	DWN	APVD
		B		REVISED PER ECO-09-007254	26MAR2009	DD	MT

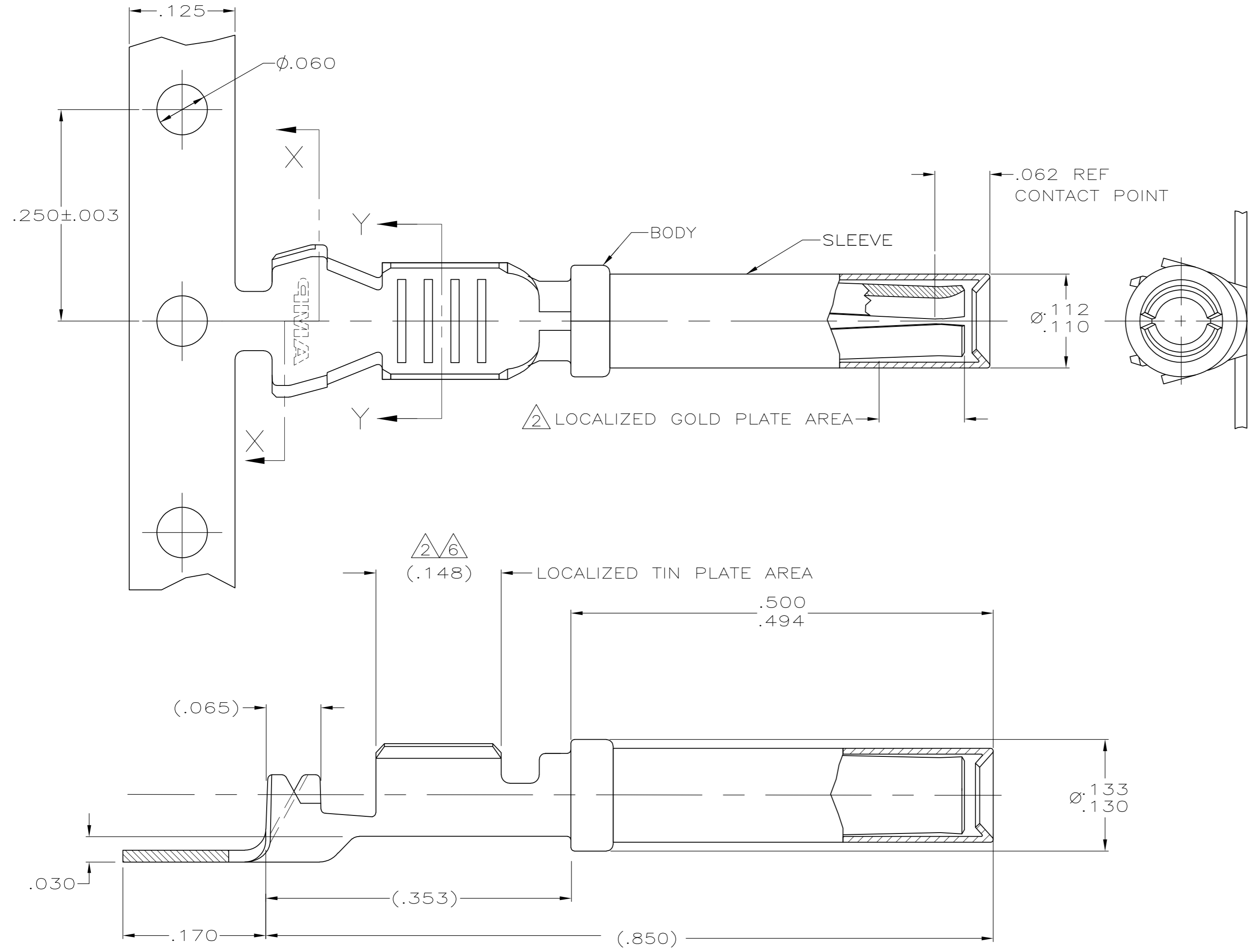

- 1 MATERIAL:
BODY: .014 THK. COPPER ALLOY.
SLEEVE: .007 THK. STAINLESS STEEL.
- 2 FINISH:
BODY: .000030 MIN SELECT GOLD IN LOCALIZED GOLD PLATE AREA, AND .000100-.000200 TIN IN LOCALIZED TIN PLATE AREA.
ALL OVER: .000040-.000080 THK. NICKEL.
SLEEVE: PASSIVATE PER 112-230-2, METHOD 1.
- 3. CONTACT TO BE LUBED WITH LUBRICANT PER TYCO ELECTRONICS P/N 22014-4.
- 4. WIRE RANGE: 20-18 AWG WITH INSULATION DIAMETERS OF .050 - .107 INCHES.
- 5. SLEEVE MUST WITHSTAND PULL OFF FORCE IN DIRECTION PARALLEL TO CENTER OF TERMINAL OF 10 LBS MINIMUM.
- 6 MATERIAL:
BODY: .000100 - .000200 TIN IN LOCALIZED TIN PLATE AREA.
ALL OVER: .000040 - .000080 THK NICKEL.
SLEEVE: PASSIVATE PER 112-230-2, METHOD 1.

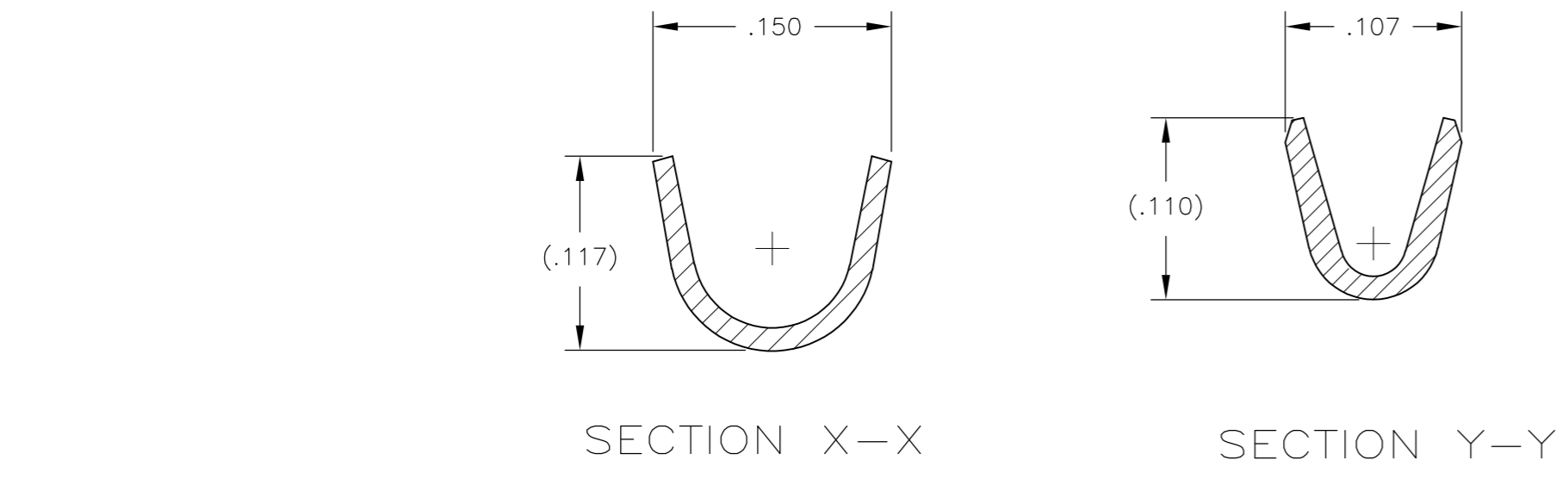

THIS DRAWING IS A CONTROLLED DOCUMENT.		DWN DL DRUMMOND 27AUG2007	Tyco Electronics Corporation Harrisburg, PA 17105-3608	
DIMENSIONS: INCHES		CHK MP TRULL 27AUG2007	ASSEMBLY, SOCKET	
TOLERANCES UNLESS OTHERWISE SPECIFIED:		APVD MP TRULL 27AUG2007	SIZE A2	CAGE CODE 00779
0 PLC ± -		PRODUCT SPEC	DRAWING NO C=1924464	RESTRICTED TO -
1 PLC ± -		APPLICATION SPEC	SCALE 10:1	SHEET 1 OF 1
2 PLC ± .02		WEIGHT -	REV B	
3 PLC ± .005		CUSTOMER DRAWING		
4 PLC ± -				
ANGLES ± -				
FINISH SEE TABLE				

1924464