

1.5MHz, 900mA Synchronous Step-Down Converter

FEATURES

- High Efficiency - Up to 95%
- Guaranteed 900mA Output Current
- 2.5V to 5.5V Input Voltage Range
- 1.5MHz Constant Frequency Operation
- No external Schottky Diode Needed
- Adjustable Output Voltages From 0.6V to VIN
- Fixed Output Voltage Options Available
- 100% Duty Cycle Low-Dropout Operation
- 0.1µA Shutdown Current
- SOT23-5 Package

TYPICAL APPLICATIONS

- Cellular phones
- DSP Core Supplies
- XDSL Applications
- USB Powered Modems
- Digital Still Cameras
- Portable Instruments
- PC Cards and Notebooks

DESCRIPTION

The FT441 is a 1.5MHz constant frequency, slope compensated current mode step down converter. It is ideal for portable equipment requiring very high current up to 0.9A from single-cell Lithium-ion batteries while still achieving over 90% efficiency during peak load conditions.

The FT441 integrates a main switch and a synchronous rectifier for high efficiency without an external Schottky diode. The FT441 automatically turns off the synchronous rectifier to increase efficiency while enters discontinuous PWM mode.

The FT441 can run at 100% duty cycle for low dropout operation, maximizing battery life in portable application. FT441 consumes less than 1uA when enter shutdown mode.

The FT441 is available in a fixed output voltages of 1.2V, 1.5V, and 1.8V, and is also available in an adjustable output voltage version capable of generating output voltages from 0.6V to VIN .The FT441 is available in a 5-pin SOT23-5 package.

TYPICAL APPLICATION CIRCUIT

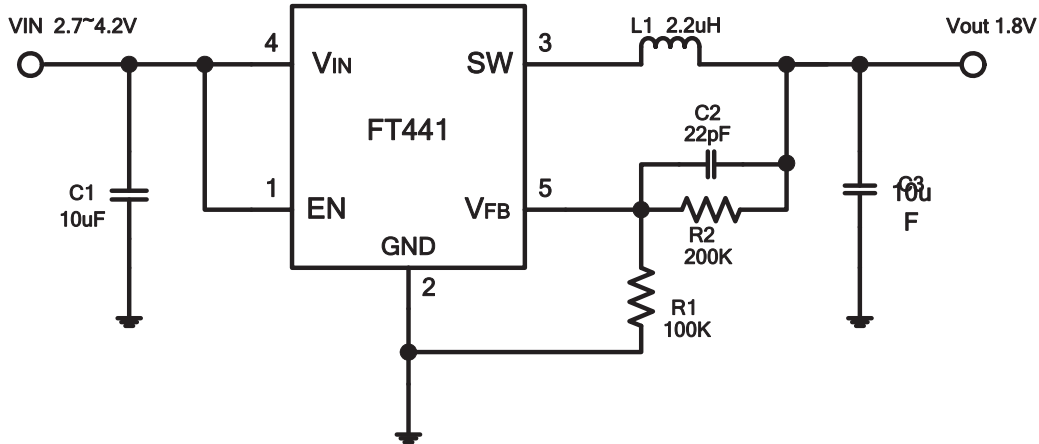

Figure 1: Typical Application Circuit

ABSOLUTE MAXIMUM RATINGS

VIN to GND.....	-0.3V to 6V
EN to GND.....	-0.3V to (VIN+0.3)
VFB to GND.....	-0.3V to (VIN+0.3)
SW to GND.....	-0.3V to (VIN+0.3)
Peak SW Sink and Source Current.....	Internally Limited
Junction to Ambient Thermal Resistance (θ_{JA}).....	250°C/W
Operating Temperature Range.....	-40°C to +85°C
Junction Temperature.....	-40°C to +150°C
Storage Temperature Range	-55°C to +150°C
Lead Temperature (Soldering, 10sec)	300°C

Stresses exceeding Maximum Ratings may damage the device. Maximum Ratings are stress ratings only. Functional operation above the Recommended Operating Conditions is not implied. Extended exposure to stresses above the Recommended Operating Conditions may affect device reliability.

PIN COMFIGURATION

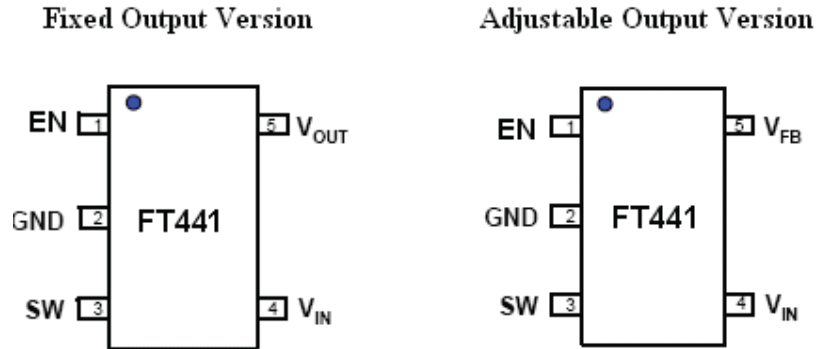

SOT23-5

Figure 2: Package Top View

TERMINAL DEFINITION

Pin	Name	Description
1	EN	Enable control input
2	GND	Ground
3	SW	Switching node, connecting to inductor
4	V _{IN}	Power input
5	V _{FB} /V _{out}	Feedback node. VFB for adjustable version, and Vout for fixed output version

Table 1

ORDERING INFORMATION

FT441①②

Designator	Symbol	Output Voltage
①	A	ADJ
	B	1.5V
	C	1.8V
	D	2.5V
	E	1.2V
	F	2.8V
	G	3.3V
Designator	Symbol	Package Type
②	a	SOT23-5

Table 2

MARKING RULE

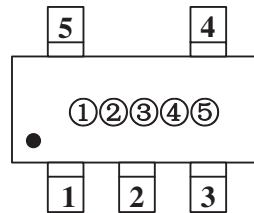

Figure 3

① Represent Product Series

Symbol	Product Series
1	FT441xx

Table 3

② Represent Output Voltage

③ Represent Package Tape

④⑤ For internal reference

BLOCK DIAGRAM

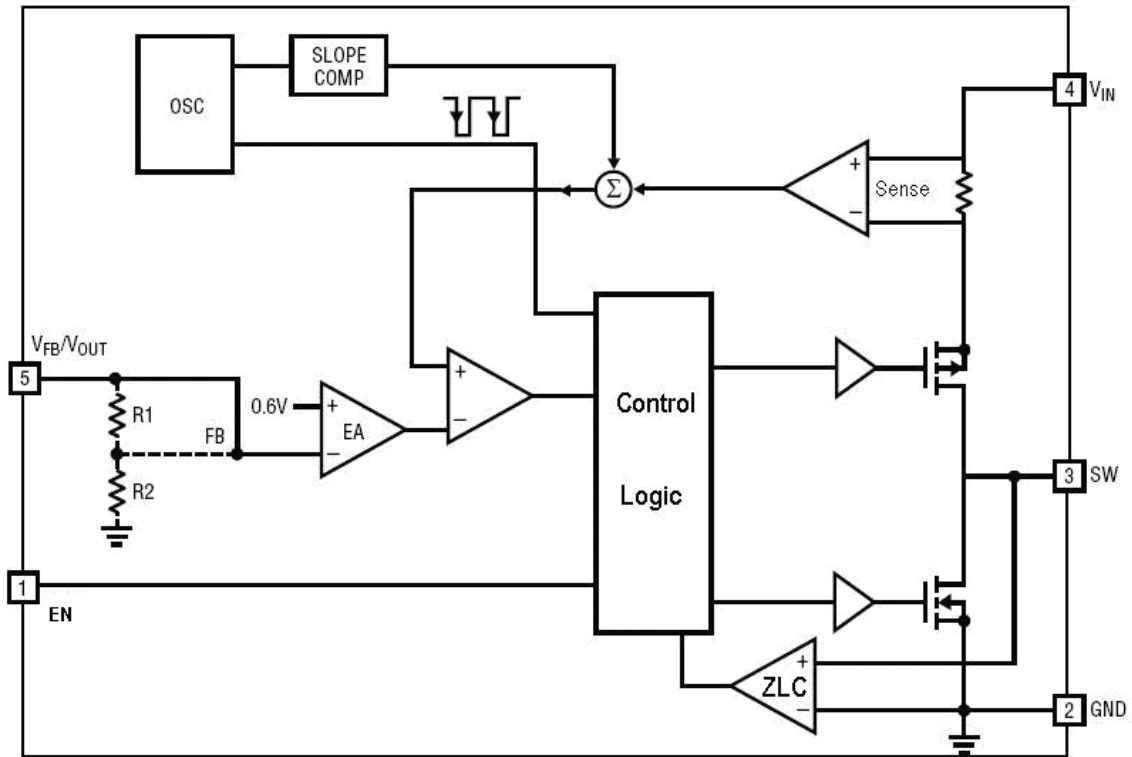

Figure 4: FT441 Block Diagram

ELECTRICAL CHARACTERISTICS

($V_{IN} = V_{EN} = 3.6V$, $T_A = 25^\circ C$ unless otherwise specified.)

Parameter	Symbol	Test Conditions	Min	Typ	Max	Unit
Input Voltage Range	V_{IN}		2.5		5.5	V
Under Voltage Lockout Threshold	V_{UVLO}	V_{IN} rising	2.2	2.35	2.5	V
Operating Supply Current		$V_{FB}=0.5$ or $V_{out}=90\%$		300	450	μA
Shutdown Supply Current		$V_{EN} = 0V$, $V_{IN} = 4.2V$		0.1	1	μA
Adjustable Version Regulation Voltage	V_{FB}	$T_A = 25^\circ C$	0.588	0.6	0.612	V
		$0 < T_A < 85^\circ C$	0.585	0.6	0.615	
		$-40^\circ C < T_A < 85^\circ C$	0.582	0.6	0.618	
Fixed Output Regulation Voltage	V_{OUT}	FT441Ba	1.455	1.5	1.545	V
		FT441Ca	1.746	1.8	1.854	
		FT441Da	2.425	2.5	2.575	
		FT441Ea	1.164	1.2	1.236	
		FT441Fa	2.716	2.8	2.884	
		FT441Ga	3.2	3.3	3.4	
Output Voltage Line Regulation		$V_{IN} = 2.5V$ to $5.5V$		0.1	0.5	$\%/V$
Output Voltage Load Regulation		$I_{OUT} = 0mA$ to $900mA$		0.5		$\%$
Inductor Current Limit	I_{LIM}	$V_{IN} = 3.6V$, $V_{FB} = 0.5V$ or $V_{out} = 90\%$	1.15	1.5	1.8	A
Oscillator Frequency	f_{SW}	$V_{FB} = 0.6$ or $V_{out} = 100\%$	1.2	1.5	1.8	MHz
		$V_{FB} = 0$ or $V_{out} = 0$		400		KHz
PMOS On Resistance	R_{ONP}	$I_{SW} = -100mA$		0.28	0.4	Ω
NMOS On Resistance	R_{ONN}	$I_{SW} = 100mA$		0.22	0.35	Ω
SW Leakage Current		$EN = 0$, $V_{IN} = 5.5V$, $V_{SW} = 5.5V$ or $0V$			1	μA
EN Threshold	V_{IH}	$V_{IN} = 2.5V$ to $5.5V$	0.3	1	1.5	V
EN Leakage Current	I_{EN}	$V_{IN} = 5.5V$, $EN = V_{IN}$		0.01	1	μA

Table 4

TYPICAL PERFORMANCE CHARACTERISTICS

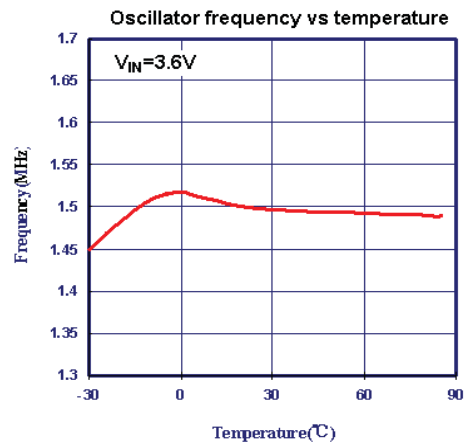
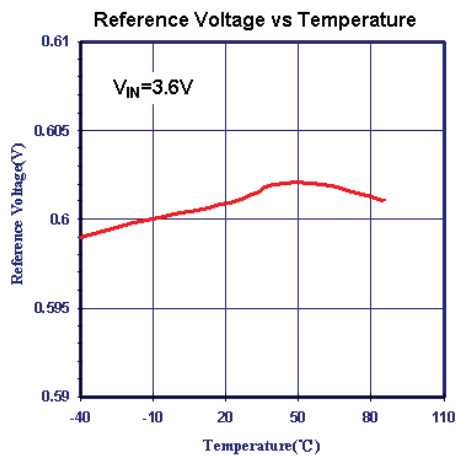
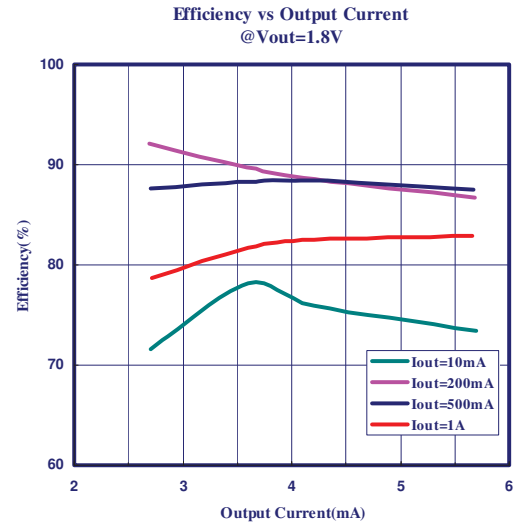
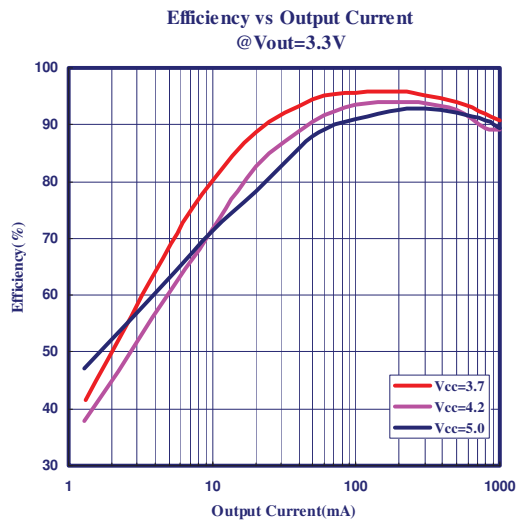
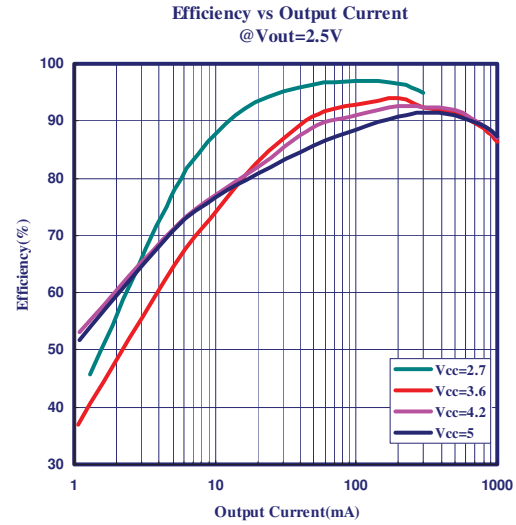
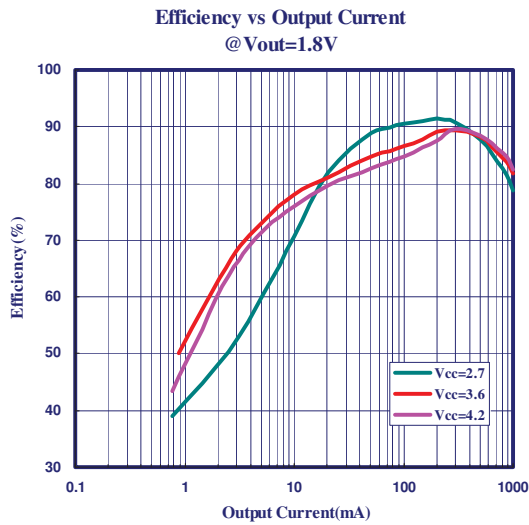

Load Regulation @ Vout=1.8V

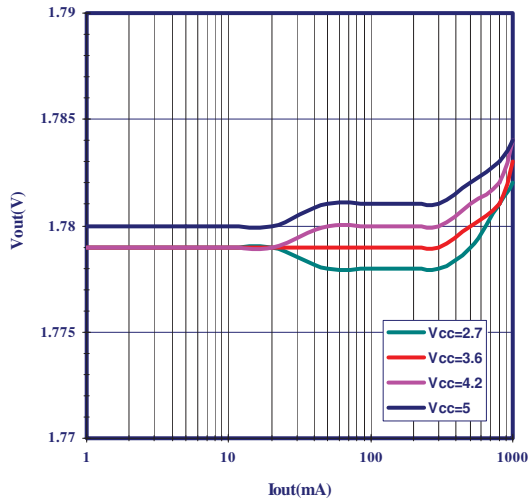

Startup from Shutdown

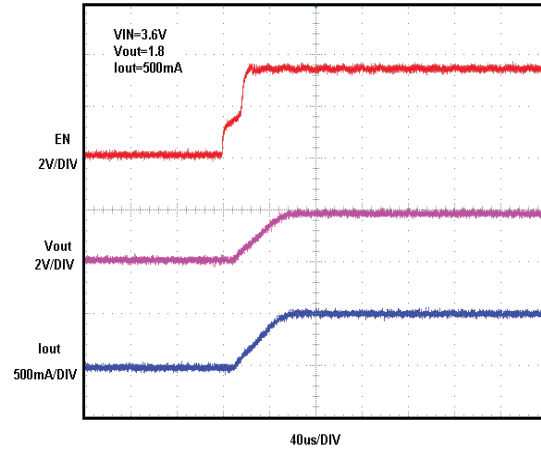

Load Step

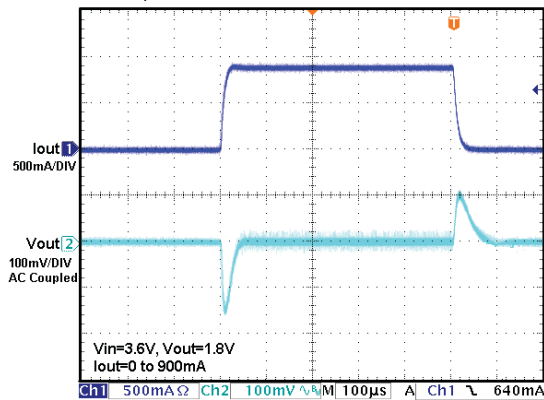

Load Step

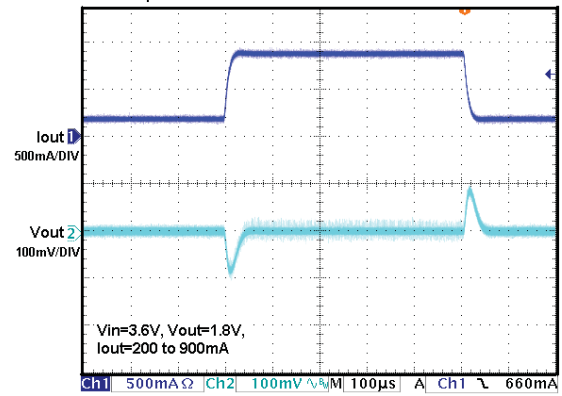

Load Step

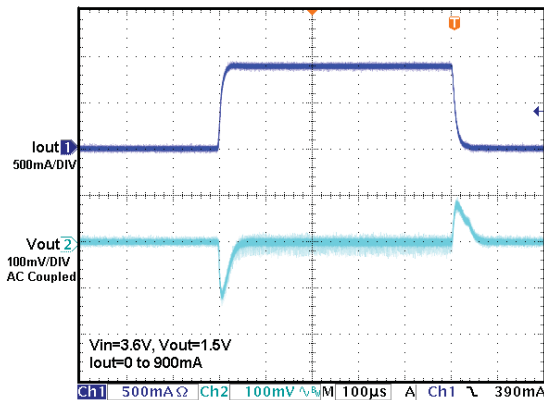

Load Step

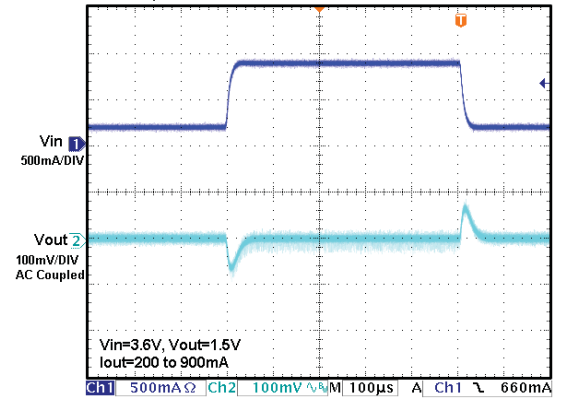

APPLICATION INFORMATION

Figure4 below shows the typical application circuit with FT441 fixed output versions.

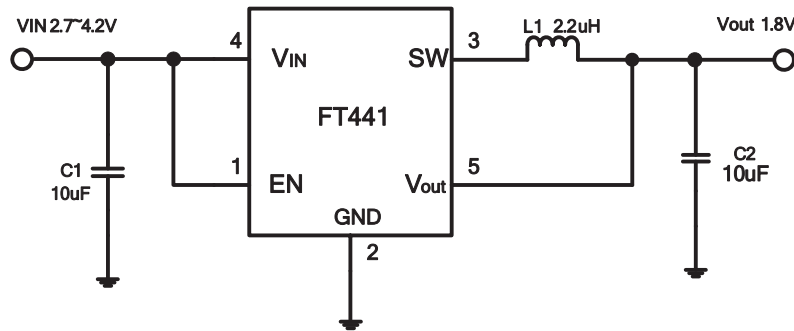

Figure 4 Typical Application Circuit with fixed output versions

Inductor Selection

Under normal operation, the inductor maintains continuous current to the output. Its value is chosen based on the desired ripple current. Large value inductors lower ripple current, and small value inductors result in higher ripple currents. The inductor value can be derived from the following equation:

$$L = \frac{V_{out} \times (V_{IN} - V_{out})}{V_{IN} \times \Delta I_L \times f_{osc}}$$

Where ΔI_L is inductor ripple current.

Input Capacitor Selection

The input capacitor reduces input voltage ripple to the converter; a 10uF ceramic capacitor is recommended for most applications.

Output Capacitor Selection

The output capacitor is required to keep the output voltage ripple small and to ensure regulation loop stability. The output capacitor must have low impedance at the switching frequency. The output ripple ΔV_{out} approximately:

$$\Delta V_{OUT} \cong \Delta I_L \times \left(ESR + \frac{1}{8fC_{OUT}} \right)$$

Output Voltage Programming

Figure1 above shows the typical application with FT4412 adjustable version. The external resistor sets the output voltage according to following equation:

$$V_{OUT} = 0.6V \times \left(1 + \frac{R2}{R1} \right)$$

SOT23-5 PACKAGE

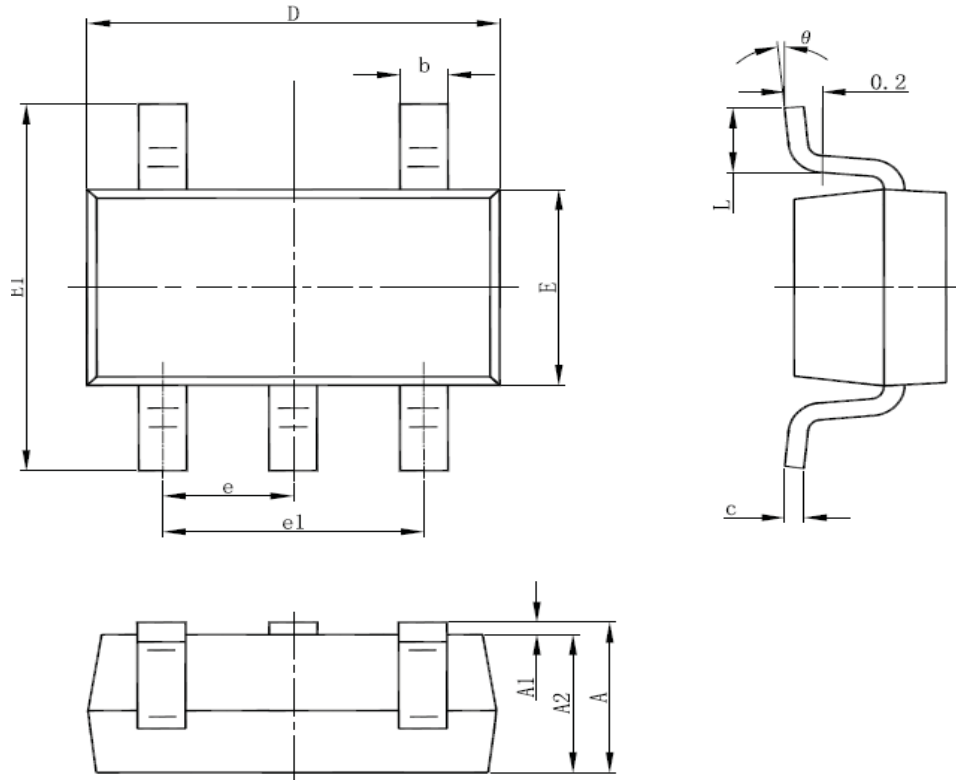

Symbol	Dimensions In Millimeters		Dimensions In Inches	
	Min	Max	Min	Max
A	1.050	1.250	0.041	0.049
A1	0.000	0.100	0.000	0.004
A2	1.050	1.150	0.041	0.045
b	0.300	0.500	0.012	0.020
c	0.100	0.200	0.004	0.008
D	2.820	3.020	0.111	0.119
E	1.500	1.700	0.059	0.067
E1	2.650	2.950	0.104	0.116
e	0.95 (BSC)		0.037 (BSC)	
e1	1.800	2.000	0.071	0.079
L	0.300	0.600	0.012	0.024
θ	0°	8°	0°	6°