

Current Mode PWM Controller

Description

The SG1846 family of control ICs provides the required features to implement Fixed Frequency, Current mode control schemes while maintaining a minimum external parts count. The advanced performance of this technique can be measured in improved line regulation, enhanced load response characteristics, and a simpler, easier-to-design control loop. Topological advantages include, inherent pulse-by-pulse current limiting capability, automatic symmetry correction for push-pull converters, and the ability to parallel “power modules” while maintaining equal current sharing.

Protection circuitry includes built-in under-voltage lockout and programmable current limit in addition to soft start capability. A shutdown function is also available which can initiate either a complete shutdown with automatic restart, or latch the supply off.

Other features include fully latched operation, double-pulse suppression, dead-time adjust capability, and a $\pm 1\%$ trimmed bandgap reference.

Features

- Automatic Feed-forward Compensation
- Programmable Pulse by Pulse Current Limiting
- Automatic Symmetry Correction in Push-pull Configuration
- Enhanced Load Response Characteristics
- Parallel Operation Capability for Modular Power Systems
- Differential Current Sense Amplifier with Wide Common-mode Range
- Double Pulse Suppression
- 200mA Totem-pole Outputs
- $\pm 1\%$ Bandgap Reference
- Under-voltage Lockout
- Soft-start and Shutdown Capability
- 500kHz Operation

High Reliability Features

- Available To MIL-STD-883 – 883, ¶ 1.2.1
- Available to DSCC
 - Standard Microcircuit Drawing (SMD)
- SGR1846 Rad-Tolerant Version Available

Block Diagram

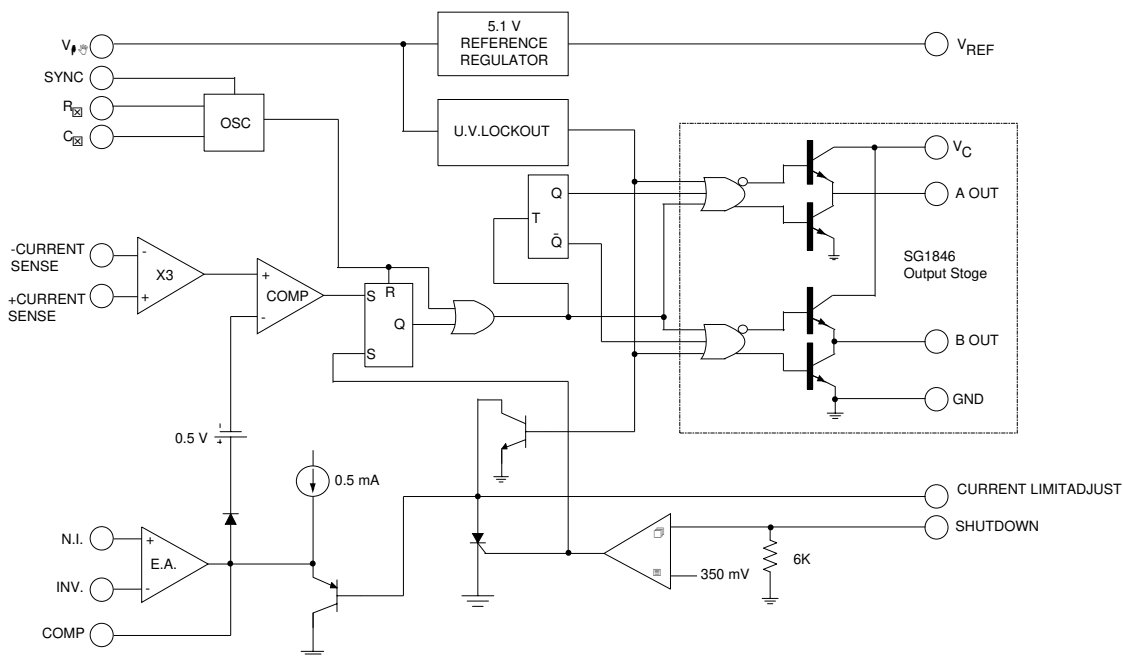
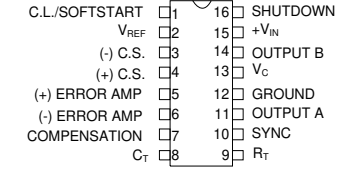
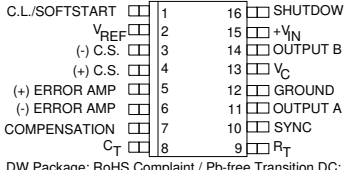
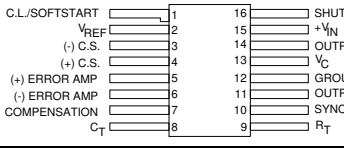
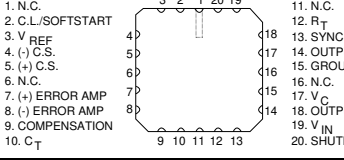

Figure 1 · Block Diagram

Connection Diagrams and Ordering Information

Ambient Temperature	Type	Package	Part Number	Packaging Type	Connection Diagram	
-55°C to 125°C	J	16-PIN CERAMIC DUAL INLINE PACKAGE	SG1846J-883B	CERDIP	 <p>N Package: RoHS Complaint / Pb-free Transition DC: 0503 N Package: RoHS / Pb-free 100% Matte Tin Lead Finish</p>	
			SG1846J-DESC			
			SG1846J			
-25°C to 85°C	N	16-PIN PLASTIC DIP PACKAGE	SG2846N	PDIP		
0°C to 70°C			SG3846N			
-25°C to 85°C	DW	16-PIN WIDEBODY PLASTIC SOIC PACKAGE ⁴	SG2846DW	SOWB	 <p>DW Package: RoHS Complaint / Pb-free Transition DC: 0516 DW Package: RoHS / Pb-free 100% Matte Tin Lead Finish</p>	
0°C to 70°C			SG3846DW			
-55°C to 125°C	F	16-PIN CERAMIC FLAT PACK PACKAGE ³	SG1846F-DESC	FLATPAK		
			SG1846L-883B			CLCC
			SG1846L-DESC			
	L	20-PIN CERAMIC LLC PACKAGE ³	SG1846L			
Notes: <ol style="list-style-type: none"> Contact factory for DESC part availability. All parts are viewed from the top. Consult factory for product availability. The SG2846 & SG3846 is available shipped as tape & reel with the addition of a -TR suffix. Hermetic Packages J, F, & L use Pb37/Sn63 hot solder lead finish, contact factory for availability of RoHS versions. 						

Absolute Maximum Ratings

Parameter	Value	Units
Supply Voltage (+V _{IN})	40	V
Collector Supply Voltage(V _C)	40	V
Analog Inputs (Pins 3, 4, 5, 6, and 16)	-0.3V to +V _{IN}	V
Logic Input	-0.3V to 5.5V	V
Source/Sink Load current (continuous)	200	mA
Source/Sink Load Current (peak, 200 ns)	500	mA
Reference Load Current	30	mA
Soft Start Sink Current	50	mA
Sync Output Current	5	mA
Error Amplifier Output Current	5	mA
Oscillator Charging current (Pin 9)	5	mA

Parameter	Value	Units
Operating Junction Temperature Hermetic (J, L, F Packages)	150	°C
Operating Junction Temperature Plastic (N, DW Package)	150	°C
Storage Temperature Range	-65 to 150	°C
Lead Temperature (Soldering, 10 Seconds)	300	°C
RoHS Peak Package Solder Reflow Temp. (40 sec. max. exp.)	260 (+0, -5)	°C
1. Values beyond which damage may occur. 2. Pin numbers refer to ceramic J package.		

Thermal Data

Parameter	Value	Units
J Package:		
Thermal Resistance-Junction to Case, θ_{JC}	30	°C/W
Thermal Resistance-Junction to Ambient, θ_{JA}	80	°C/W
N Package:		
Thermal Resistance-Junction to Case, θ_{JC}	40	°C/W
Thermal Resistance-Junction to Ambient, θ_{JA}	65	°C/W
DW Package:		
Thermal Resistance-Junction to Case, θ_{JC}	40	°C/W
Thermal Resistance-Junction to Ambient, θ_{JA}	95	°C/W
F Package:		
Thermal Resistance-Junction to Case, θ_{JC}	70	°C/W
Thermal Resistance-Junction to Ambient, θ_{JA}	115	°C/W
L Package:		
Thermal Resistance-Junction to Case, θ_{JC}	35	°C/W
Thermal Resistance-Junction to Ambient, θ_{JA}	120	°C/W
Notes: 1. Junction Temperature Calculation: $T_J = T_A + (P_D \times \theta_{JA})$. 2. The above numbers for θ_{JC} are maximums for the limiting thermal resistance of the package in a standard mounting configuration. The θ_{JA} numbers are meant to be guidelines for the thermal performance of the device/PCBoard system. All of the above assume no ambient airflow.		

Recommended Operating Conditions

Parameter	Value	Units
Supply Voltage Range	8 to 40	V
Collector Supply Voltage Range	4.5 to 40	V
Source/Sink Output Current (continuous)	100	mA
Source/Sink Output Current (peak 200ns)	200	mA
Reference Load Current	0 to 10	mA
Oscillator Frequency Range	1 to 500	kHz
Oscillator Timing Resistor (R_T)	2 to 100	k Ω
Oscillator Timing Capacitor (C_T)	1 to 100	nF
Operating Ambient Temperature Range		
SG1846	55 to 125	°C
SG2846	25 to 85	°C
SG3846	0 to 70	°C
Note: Range over which the device is functional.		

Electrical Characteristics

Unless otherwise specified, these specifications apply over the operating ambient temperatures for SG1846 with $-55^{\circ}\text{C} \leq T_A \leq 125^{\circ}\text{C}$, SG2846 with $-25^{\circ}\text{C} \leq T_A \leq 85^{\circ}\text{C}$, SG3846 with $0^{\circ}\text{C} \leq T_A \leq 70^{\circ}\text{C}$, $+V_{IN} = 15\text{V}$. Low duty cycle pulse testing techniques are used which maintains junction and case temperatures equal to the ambient temperature.

Symbol	Parameter	Test Condition	SG1846 SG2846			SG3846			Units
			Min	Typ	Max	Min	Typ	Max	
Reference Section									
V_{REF}	Output Voltage	$T_J = 25^{\circ}\text{C}$, $I_O = 1\text{mA}$	5.05	5.10	5.15	5.00	5.10	5.20	V
V_{REG}	Line Regulation	$V_{IN} = 8\text{V to } 40\text{V}$		5	20		5	20	mV
I_{REG}	Load Regulation	$I_L = 1\text{mA to } 10\text{mA}$		3	15		3	15	mV
	Temperature Stability ¹			0.4			0.4		mV/ $^{\circ}\text{C}$
	Total Output Variation ¹	Line, Load and Temperature	5.00		5.20	4.95		5.25	V
	Output Noise Voltage ¹	$10\text{Hz} \leq f \leq 10\text{kHz}$. $T_J = 25^{\circ}\text{C}$		100			100		μV
	Long Term Stability ¹	$T_J = 125^{\circ}\text{C}$, 1000Hrs.		5			5		mV
$V_{REF_{ISC}}$	Short Circuit Output Current	$V_{REF} = 0\text{V}$	-10	-45		-10	-45		mA
Oscillator Section⁶									
OSC	Initial Accuracy	$T_J = 25^{\circ}\text{C}$	39	43	47	39	43	47	kHz
OSC_{VS}	Voltage Stability	$V_{IN} = 8\text{V to } 40\text{V}$		1	2		1	2	%
OSC_{TS}	Temperature Stability ¹	Over Operating Range		1			1		%
VOH	Sync Output High Level		3.9	4.35		3.9	4.35		V
VOL	Sync Output Low Level			2.3	2.5		2.3	2.5	V
VIH	Sync Input High Level	Pin 8 = 0V	3.9			3.9			V
VIL	Sync Input Low Level	Pin 8 = 0V			2.5			2.5	V
ILL	Sync Input Current	Sync Voltage = 5.25V, Pin 8 = 0V		1.2	1.5		1.2	1.5	mA

Symbol	Parameter	Test Condition	SG1846 SG2846			SG3846			Units
			Min	Typ	Max	Min	Typ	Max	
Error AMP Section									
EA _{VOS}	Input Offset Voltage			0.5	5		0.5	10	mV
EA _{IIB}	Input Bias Current			-0.6	-1		-0.6	-2	μA
EA _{IOS}	Input Offset Current			40	250		40	250	nA
EA _{CM}	Common Mode Range	V _{IN} = 8V to 40V	0		V _{IN} -2V	0		V _{IN} -2V	V
EA _{AV}	Open Loop Voltage Gain	V _O = 1.2V to 3V, V _{CM} = 2V	80	105		80	105		dB
EA _{UGB}	Unity Gain Bandwidth ¹	T _J = 25°C	0.7	1.0		0.7	1.0		MHz
EA _{CMRR}	CMRR	V _{CM} = 0V to 38V, V _{IN} = 40V	75	100		75	100		dB
EA _{PSRR}	PSRR	V _{IN} = 8V to 40V	80	105		80	105		dB
EA _{SNK}	Output Sink Current	V _{ID} = -15mV to -5V, V _{PIN 7} = 1.2V	2	6		2	6		mA
EA _{SRC}	Output Source Current	V _{ID} = 15mV to 5V, V _{PIN 7} = 2.5V	-0.4	-0.5		-0.4	-0.5		mA
EA _{VOH}	High Level Output Voltage	R _L = 15kΩ (Pin 7)	4.3	4.6		4.3	4.6		V
EA _{VOL}	Low Level Output Voltage	R _L = 15kΩ (Pin 7)		0.7	1		0.7	1	V
Current Sense Amplifier Section									
CS _{AV}	Amplifier Gain ^{2 & 3}	V _{PIN 3} = 0V, Pin 1 Open	2.5	2.75	3.0	2.5	2.75	3.0	V
	Maximum Differential ³ Input Signal ² (V _{PIN 4} - V _{PIN 3})	Pin 1 Open R _L = 15kΩ (Pin 7)	1.1	1.2		1.1	1.2		V
	Input Offset Voltage ²	V _{PIN 1} = 0.5V, Pin 7 Open		5	25		5	25	mV
CS _{CMRR}	CMRR	V _{CM} = 1V to 12V	60	83		60	83		dB
CS _{PSRR}	PSRR	V _{IN} = 8V to 40V	60	84		60	84		dB
CS _{IIB}	Input Bias Current ²	V _{PIN 1} = 0.5V, Pin 7 Open		-2.5	-10		-2.5	-10	μA
CS _{IOC}	Input Offset Current ²	V _{PIN 1} = 0.5V, Pin 7 Open		0.08	1		0.08	1	μA
CS _{CM}	Input Common Mode Range		0		V _{IN} -3	0		V _{IN} -3	V
	Delay to Outputs ¹	T _J = 25°C		200	500		200	500	ns
Current Limit Adjust Section									
	Current Limit Offset Voltage ²	V _{PIN 3} = 0, V _{PIN 4} = 0V, Pin 7 Open	0.45	0.5	0.55	0.45	0.5	0.55	V
CL _{IIB}	Input Bias Current	V _{PIN 5} = V _{REF} , V _{PIN 6} = 0V		-10	-30		-10	-30	μA

Symbol	Parameter	Test Condition	SG1846 SG2846			SG3846			Units
			Min	Typ	Max	Min	Typ	Max	
Shutdown Terminal Section									
SD	Threshold Voltage		250	350	400	250	350	400	mV
	Input Voltage Range		0		V _{IN}	0		V _{IN}	V
SD _{LC}	Minimum Latching Current; (I _{PIN1}) ⁴		3.0	1.5		3.0	1.5		mA
	Maximum Non-Latching Current; (I _{PIN1}) ⁵			1.5	0.8		1.5	0.8	mA
SD _{DELAY}	Delay to Outputs ¹	T _J = 25°C		300	600		300	600	ns
Output Section									
	Collector Emitter Voltage		40			40			V
	Collector Leakage Current	V _C = 40V			200			200	μA
	Output Low Level	I _{SINK} = 20mA		0.1	0.4		0.1	0.4	V
		I _{SINK} = 100mA		0.4	2.1		0.4	2.1	V
	Output High Level	I _{SOURCE} = 20mA	13	13.5		13	13.5		V
		I _{SOURCE} = 100mA	12	13.5		12	13.5		V
	Rise Time ¹	C _L = 1nF, T _J = 25°C		50	300		50	300	ns
	Fall Time ¹	C _L = 1nF, T _J = 25°C		50	300		50	300	ns
Under-Voltage Lockout Section									
	Start-Up Threshold			7.7	8.0		7.7	8.0	V
	Threshold Hysteresis			0.75			0.75		V
Total Standby Current									
I _Q	Supply Current			17	21		17	21	mA
Notes:									
1. These parameters, although guaranteed over the recommended operating conditions, are not tested in the production.									
2. Parameter measured at trip point of latch with V _{PIN5} = V _{REF} , V _{PIN6} = 0V.									
3. Amplifier gain defined as : $G = \frac{\Delta V_{PIN2}}{\Delta V_{PIN4}}$; V _{PIN4} = 0V to 1.0V									
4. Current into Pin 1 guaranteed to latch circuit in shutdown state.									
5. Current into Pin 1 guaranteed not to latch circuit in shutdown state.									
6. R _T = 10kΩ, C _T = 4.7nF									

Characteristic Curves

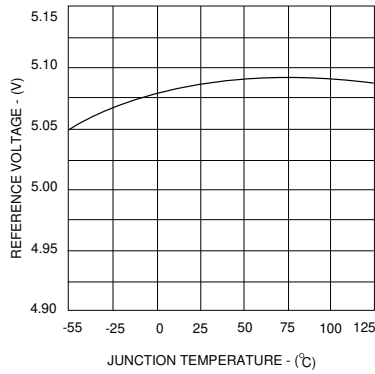

Figure 2 · Reference Voltage Vs. Temperature

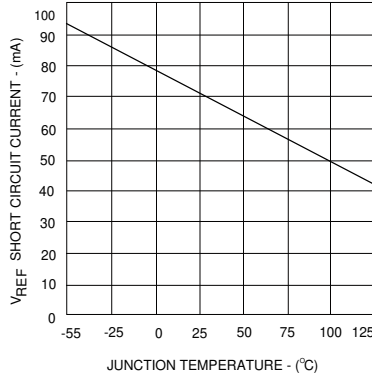

Figure 3 · V_{REF} Short Circuit Current Vs. Temperature

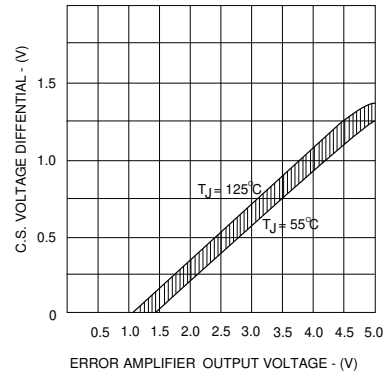

Figure 4 · Current Sense Threshold Vs. Error Amplifier Output

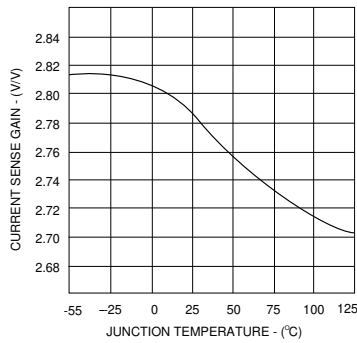

Figure 5 · Current Sense Gain Vs. Temperature

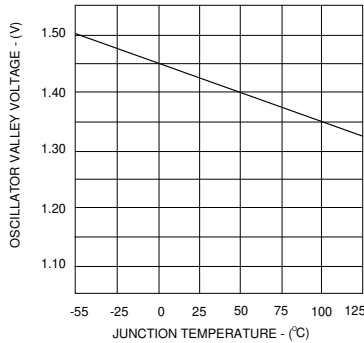

Figure 6 · Oscillator Valley Voltage Vs. Temperature

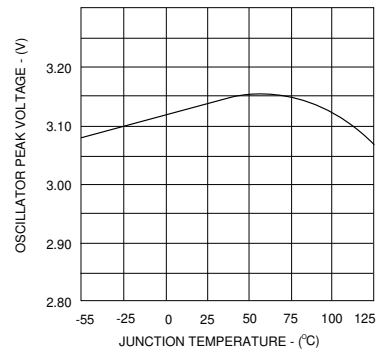

Figure 7 · Oscillator Peak Voltage Vs. Temperature

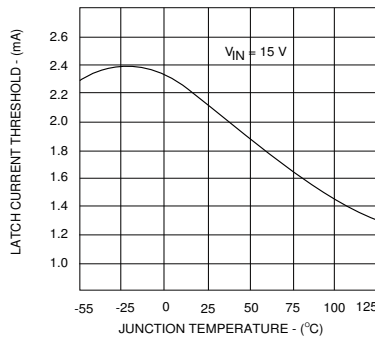

Figure 8 · Minimum SCR Latch Current

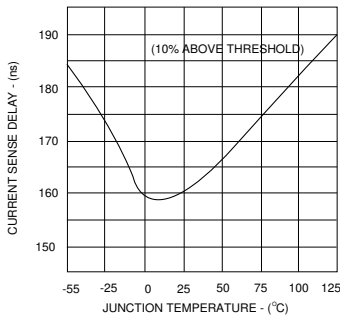

Figure 9 · Current Sense Delay Vs. Temperature

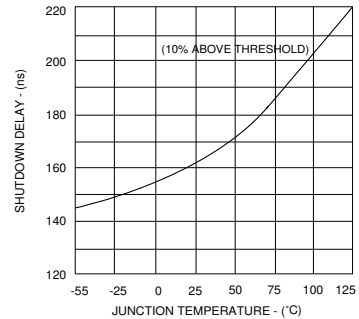

Figure 10 · Shutdown Delay to Output Vs. Temperature

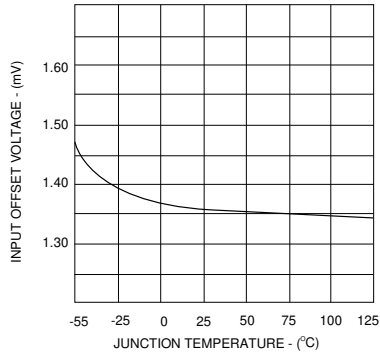

Figure 11 · Error Amplifier Input Offset Voltage Vs. Temperature

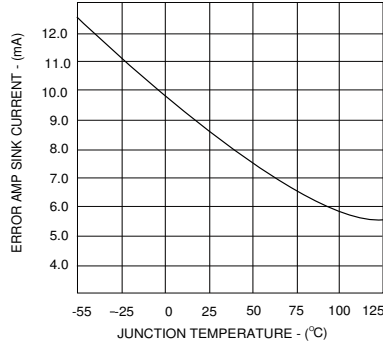

Figure 12 · Error AMP Sink Current Vs. Temperature

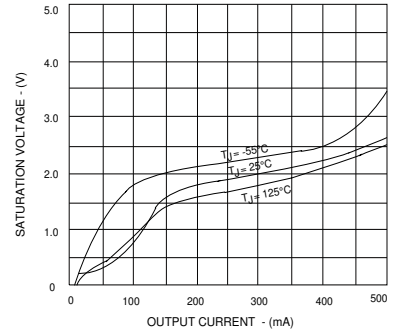

Figure 13 · Output Transistor Saturation Voltage Vs. Output Current (Sink Transistor)

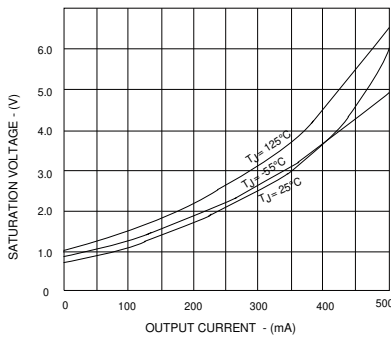

Figure 14 · Output Transistor Saturation Voltage Vs. Output Current (Source Transistor)

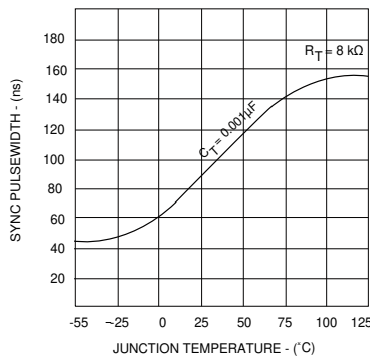

Figure 15 · Sync Pulsewidth Vs. Temperature

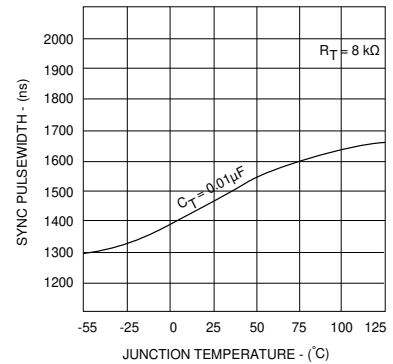

Figure 16 · Sync Pulsewidth Vs. Temperature

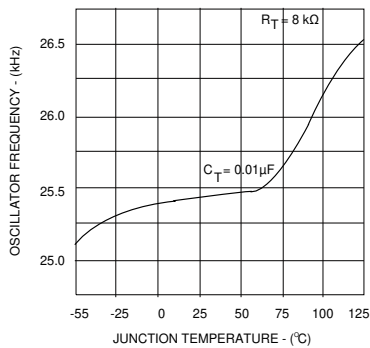

Figure 17 · Oscillator Frequency Vs. Temperature

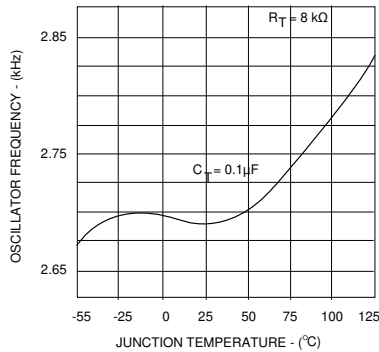

Figure 18 · Oscillator Frequency Vs. Temperature

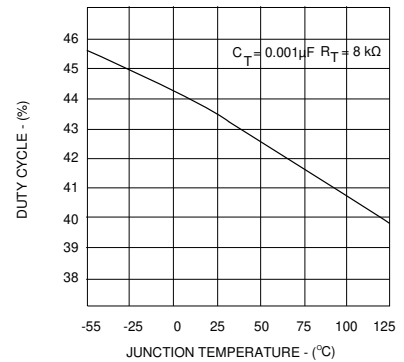

Figure 19 · Duty Cycle Vs. Temperature

Application Information

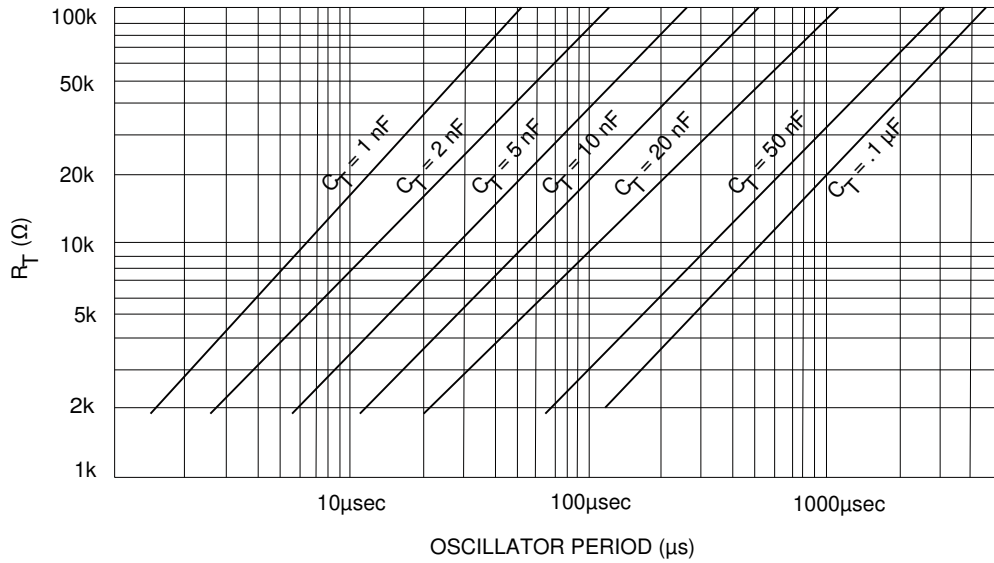

Figure 20 · Oscillator Frequency Curves

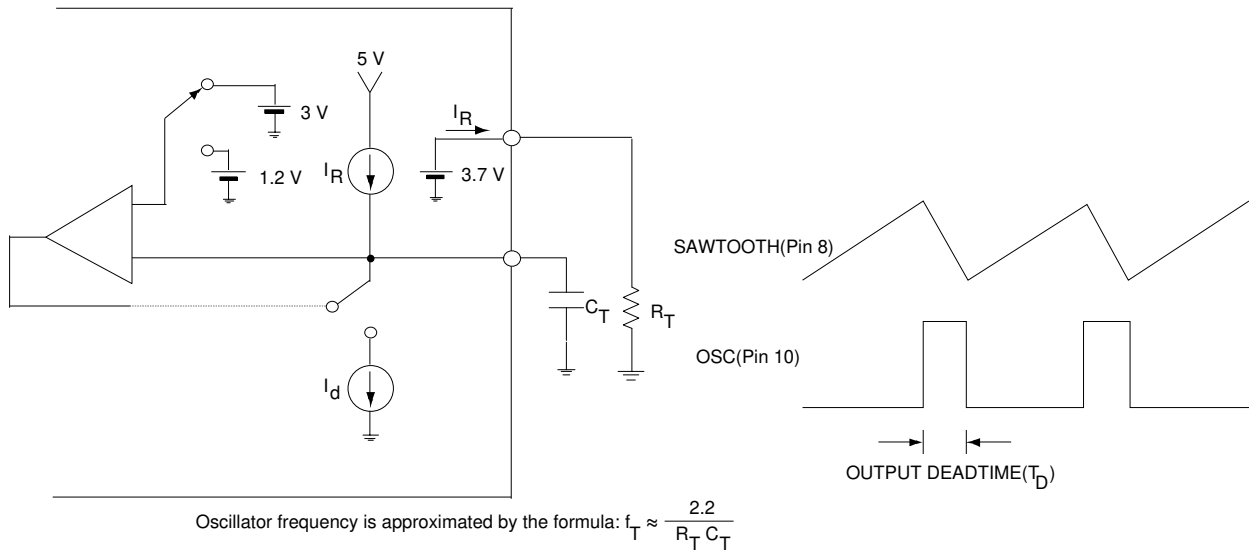

Figure 21 · Oscillator Circuit

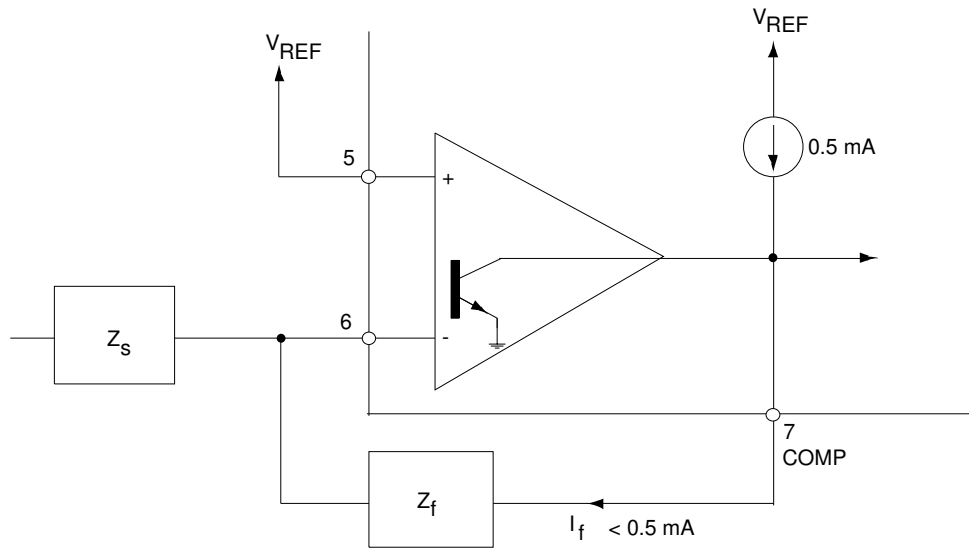

Figure 22 · Error Amp Output Configuration (Error amplifier can source up to 0.5 mA)

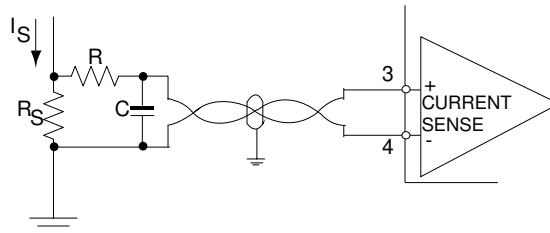

Figure 23 · Current Sense AMP Connections

A small RC filter may be required in some applications to reduce switch transients. Differential input allows remote noise free switching.

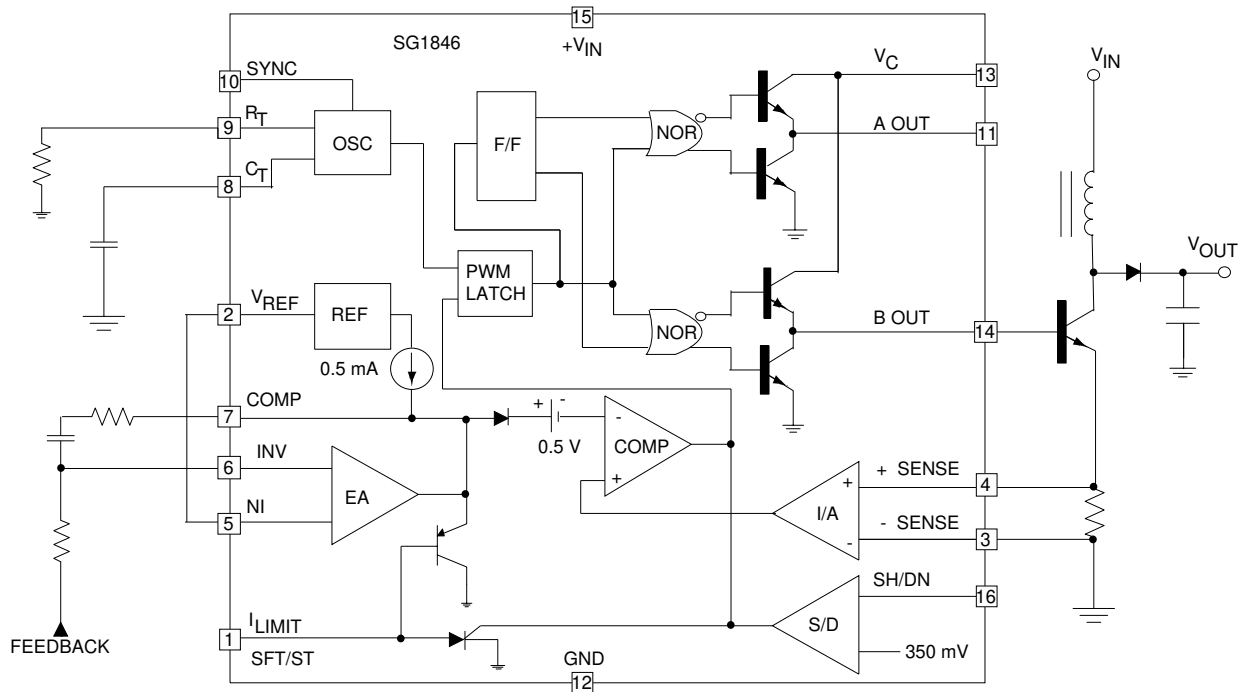

Figure 24 · Single Ended Boost Configuration

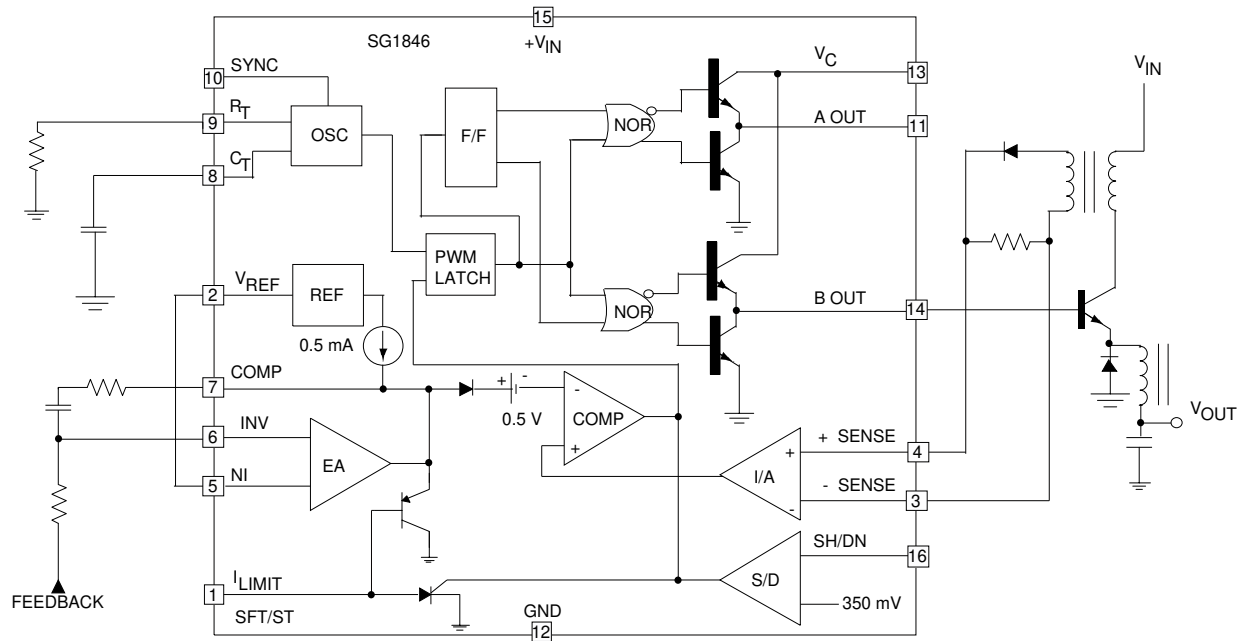

Figure 25 · Buck Converter with Current Sense Winding

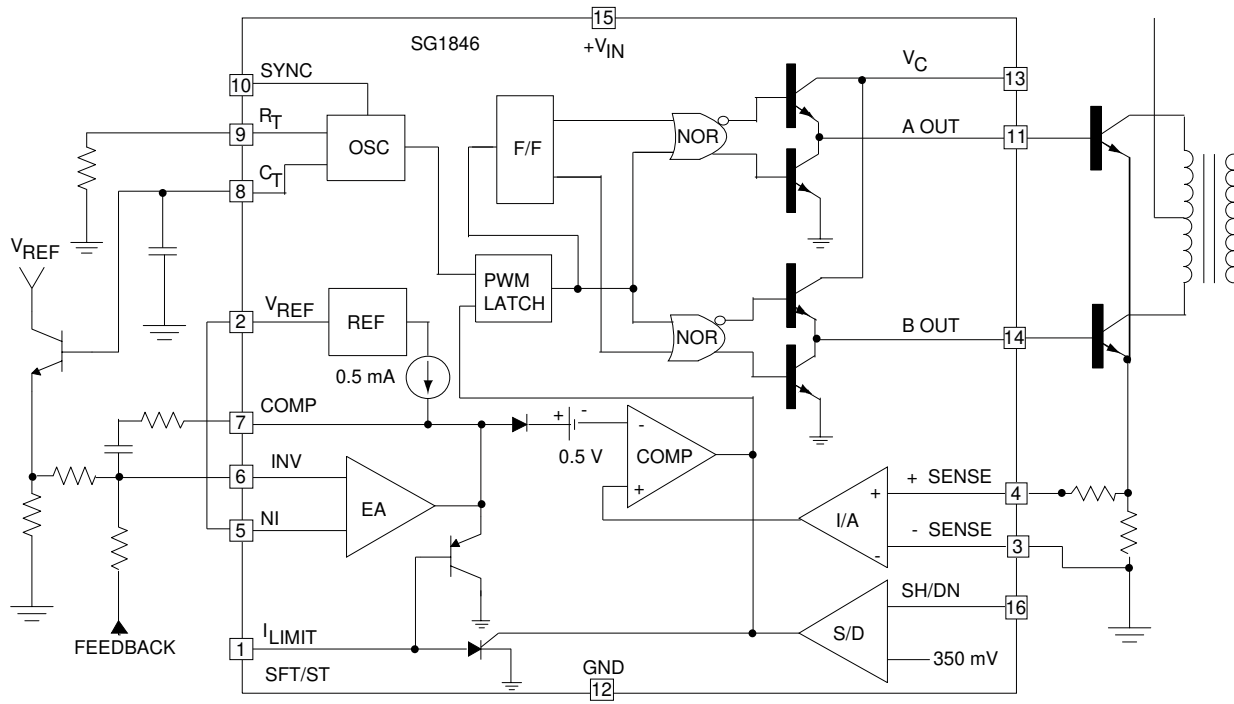

Figure 26 · Push/Pull Converter with Slope Compensation

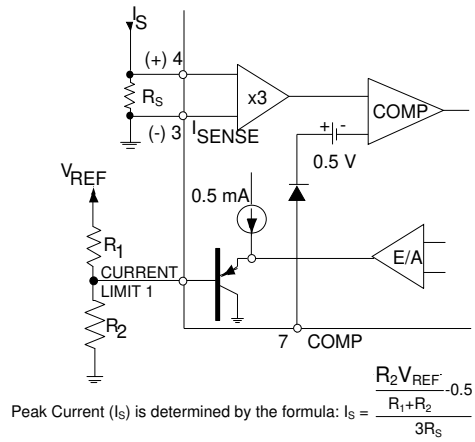

Figure 27 · Pulse by Pulse Current Limiting

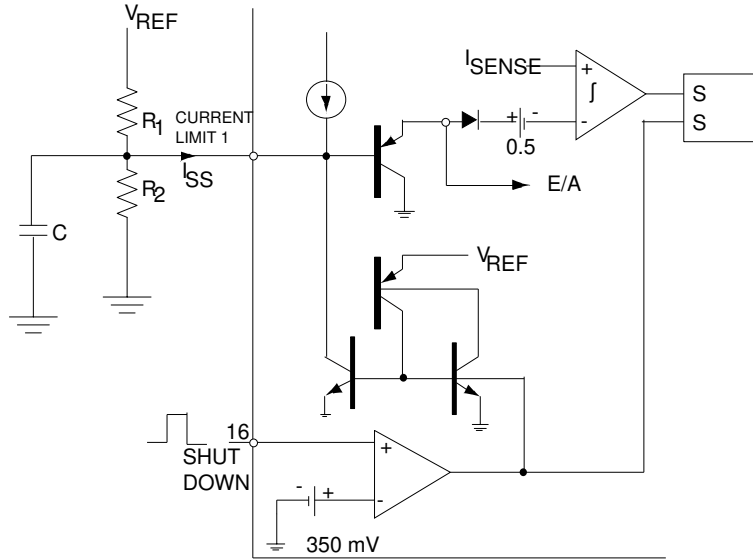

Figure 28 · Soft Start and Shutdown/Restart Functions

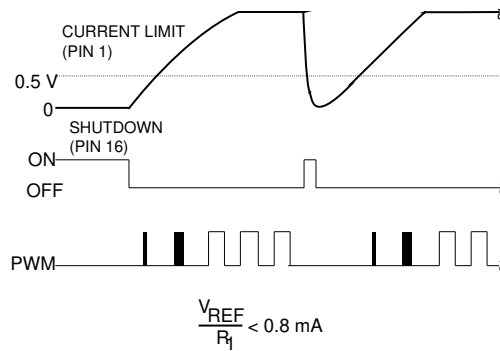

Figure 29 · Shutdown with Auto-Restart

If $\frac{V_{REF}}{R_1} < 0.8 \text{ mA}$, the shutdown latch commutates.
when $I_{SS} < 0.8 \text{ mA}$, a restart cycle will be initiated.

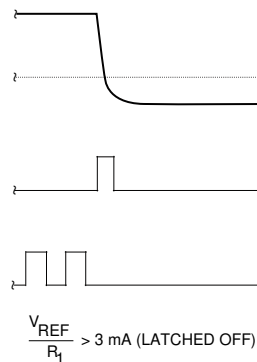
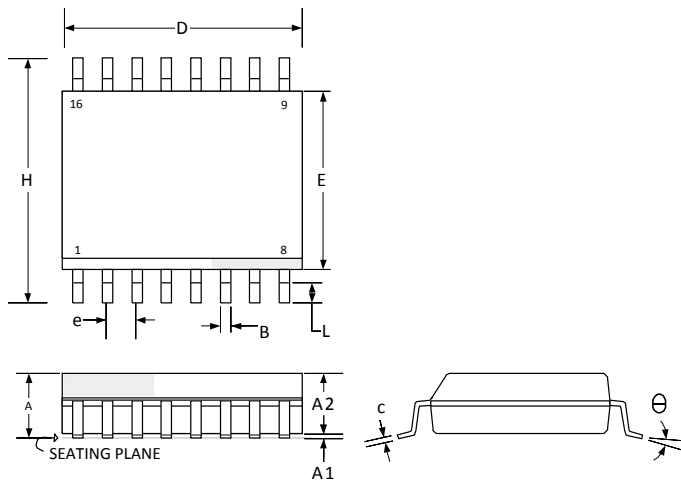

Figure 30 · Shutdown without Auto-Restart (Latched)

If $\frac{V_{REF}}{R_1} > 3 \text{ mA}$, the device will latch off until power is recycled.

Package Outline Dimensions

Controlling dimensions are in inches, metric equivalents are shown for general information.



Dim	MILLIMETERS		INCHES	
	MIN	MAX	MIN	MAX
A	2.06	2.65	0.081	0.104
A1	0.10	0.30	0.004	0.012
A2	2.03	2.55	0.080	0.100
B	0.25	0.51	0.010	0.020
c	0.23	0.32	0.009	0.013
D	-	10.67	-	0.420
E	7.40	7.75	0.291	0.305
e	1.27 BSC		0.05 BSC	
H	10.00	10.65	0.394	0.419
L	0.40	1.27	0.016	0.050
θ	0°	8°	0°	8°
*LC	-	0.10	-	0.004

*Lead co planarity

Note:

Dimensions do not include protrusions; these shall not exceed 0.155mm (.006") on any side. Lead dimension shall not include solder coverage.

Figure 31 · DW 16-Pin SOWB Package Dimensions

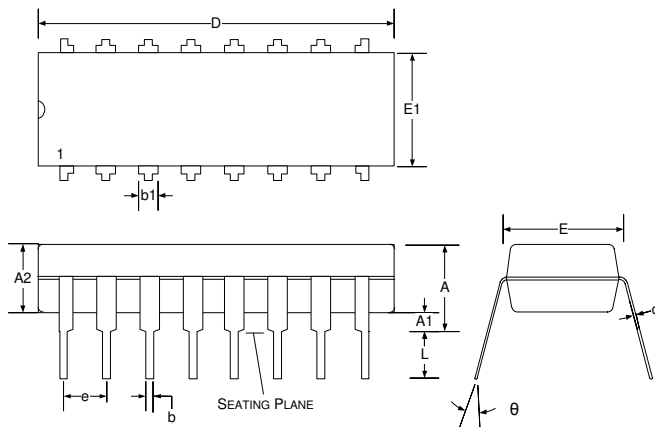

Dim	MILLIMETERS		INCHES	
	MIN	MAX	MIN	MAX
A	-	5.33	-	0.210
A1	0.38	-	0.015	-
A2	3.30 Typ.		0.130 Typ.	
b	0.36	0.56	0.014	0.022
b1	1.14	1.78	0.045	0.070
c	0.20	0.36	0.008	0.014
D	18.67	19.69	0.735	0.775
e	2.54 BSC		0.100 BSC	
E	7.62	8.26	0.300	0.325
E1	6.10	7.11	0.240	0.280
L	2.92	0.381	0.115	0.150
θ	-	15°	-	15°

Note:

Dimensions do not include protrusions; these shall not exceed 0.155mm (.006") on any side. Lead dimension shall not include solder coverage.

Figure 32 · N 16-Pin Plastic Dual Inline Package Dimensions

PACKAGE OUTLINE DIMENSIONS

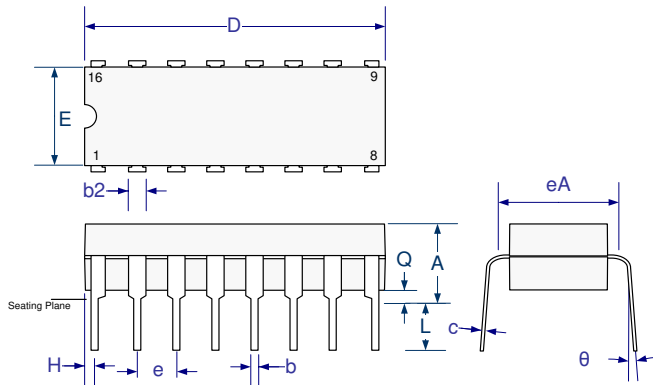

Dim	MILLIMETERS		INCHES	
	MIN	MAX	MIN	MAX
A		5.08		0.200
b	0.38	0.51	0.015	0.020
b2	1.04	1.65	0.045	0.065
c	0.20	0.38	0.008	0.015
D	19.30	19.94	0.760	0.785
E	5.59	7.11	0.220	0.280
e	2.54 BSC		0.100 BSC	
eA	7.37	7.87	0.290	0.310
H	0.63	1.78	0.025	0.070
L	3.18	5.08	0.125	0.200
alpha	-	15°	-	15°
Q	0.51	1.02	0.020	0.040

Note:

Dimensions do not include protrusions; these shall not exceed 0.155mm (.006") on any side. Lead dimension shall not include solder coverage.

Figure 33 · J 16-Pin Ceramic Dual Inline Package Dimensions

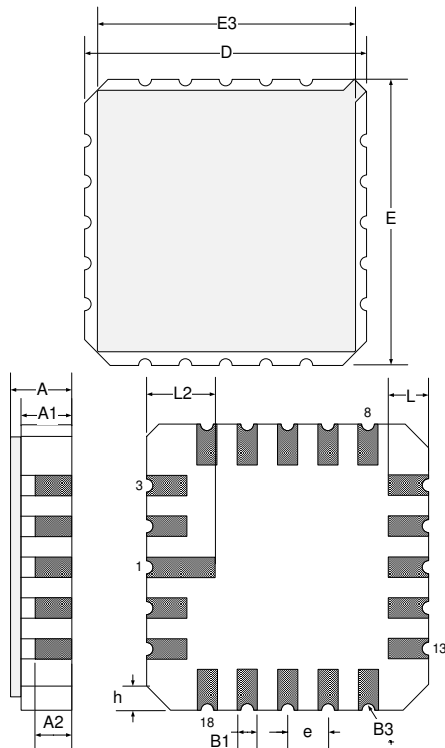

Dim	MILLIMETERS		INCHES	
	MIN	MAX	MIN	MAX
D/E	8.64	9.14	0.340	0.360
E3	-	8.128	-	0.320
e	1.270 BSC		0.050 BSC	
B1	0.635 TYP		0.025 TYP	
L	1.02	1.52	0.040	0.060
A	1.626	2.286	0.064	0.090
h	1.016 TYP		0.040 TYP	
A1	1.372	1.68	0.054	0.066
A2	-	1.168	-	0.046
L2	1.91	2.41	0.075	0.95
B3	0.203R		0.008R	

Note:

All exposed metalized area shall be gold plated 60 micro-inch minimum thickness over nickel plated unless otherwise specified in purchase order.

Figure 34 · L 20-Pin Ceramic Leadless Chip Carrier (LCC) Package Outline Dimensions

PACKAGE OUTLINE DIMENSIONS

Controlling dimensions are in inches, metric equivalents are shown for general information.

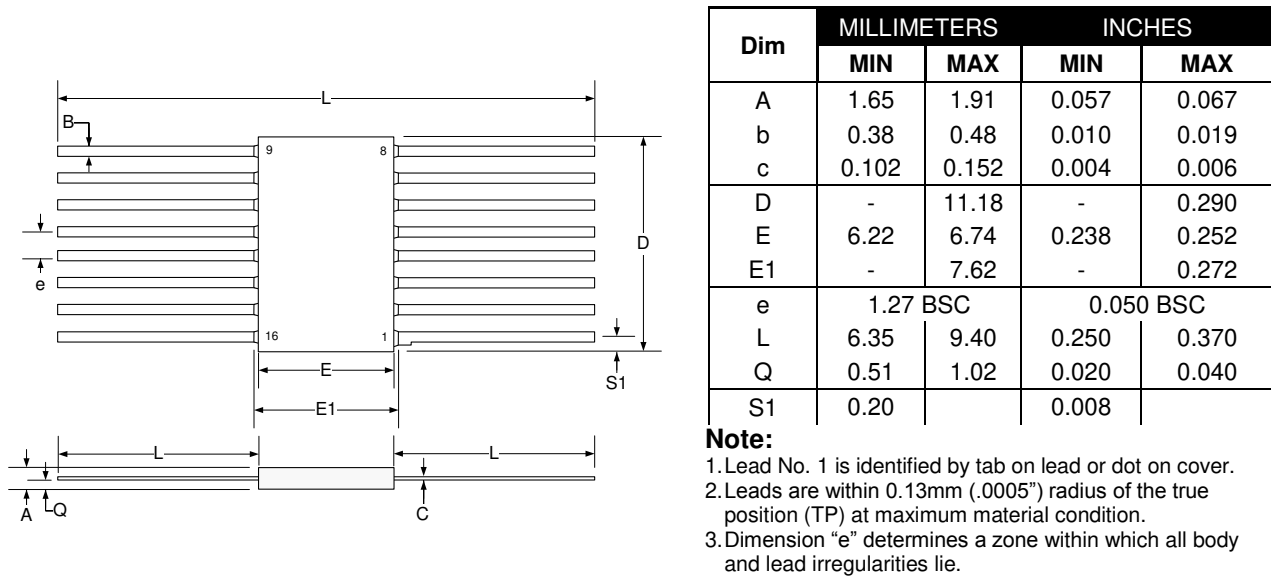

Figure 35 · F 16-Pin Ceramic Flatpack Package Dimensions



Microsemi Corporate Headquarters
One Enterprise, Aliso Viejo,
CA 92656 USA

Within the USA: +1 (800) 713-4113
Outside the USA: +1 (949) 380-6100
Sales: +1 (949) 380-6136
Fax: +1 (949) 215-4996

E-mail: sales.support@microsemi.com

© 2014 Microsemi Corporation. All rights reserved. Microsemi and the Microsemi logo are trademarks of Microsemi Corporation. All other trademarks and service marks are the property of their respective owners.

Microsemi Corporation (Nasdaq: MSCC) offers a comprehensive portfolio of semiconductor and system solutions for communications, defense & security, aerospace and industrial markets. Products include high-performance and radiation-hardened analog mixed-signal integrated circuits, FPGAs, SoCs and ASICs; power management products; timing and synchronization devices and precise time solutions, setting the world's standard for time; voice processing devices; RF solutions; discrete components; security technologies and scalable anti-tamper products; Power-over-Ethernet ICs and midspans; as well as custom design capabilities and services. Microsemi is headquartered in Aliso Viejo, Calif., and has approximately 3,400 employees globally. Learn more at www.microsemi.com.

Microsemi makes no warranty, representation, or guarantee regarding the information contained herein or the suitability of its products and services for any particular purpose, nor does Microsemi assume any liability whatsoever arising out of the application or use of any product or circuit. The products sold hereunder and any other products sold by Microsemi have been subject to limited testing and should not be used in conjunction with mission-critical equipment or applications. Any performance specifications are believed to be reliable but are not verified, and Buyer must conduct and complete all performance and other testing of the products, alone and together with, or installed in, any end-products. Buyer shall not rely on any data and performance specifications or parameters provided by Microsemi. It is the Buyer's responsibility to independently determine suitability of any products and to test and verify the same. The information provided by Microsemi hereunder is provided "as is, where is" and with all faults, and the entire risk associated with such information is entirely with the Buyer. Microsemi does not grant, explicitly or implicitly, to any party any patent rights, licenses, or any other IP rights, whether with regard to such information itself or anything described by such information. Information provided in this document is proprietary to Microsemi, and Microsemi reserves the right to make any changes to the information in this document or to any products and services at any time without notice.