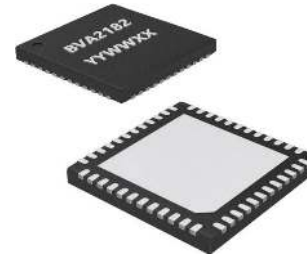


### Device Features

- 48Pin 7 x 7 x 0.9mm QFN Package
- Integrates Amp1(Gain Block), DSA1 ,DSA2 Amp2(Gain Block) Functionality
- Wide Power supply range of +2.7~5.5V(DSA1,2)
- Single Fixed +5.0V supply (Amp1,2)
- 0.5-3.8GHz Broadband Performance
- 33.4dB Gain at 1.9GHz (with 3dB Pad in Application Circuit)
- 1.6dB Noise Figure at max gain setting at 1.9GHz
- 21.2dBm P1dB at 1.9GHz
- 38.2dBm OIP3 at 1.9GHz(5dBm per tone)
- Attenuation: 0.5 dB steps to 31.5 dB
- Safe attenuation state transitions
- Monotonicity: 0.5 dB up to 4 GHz
- High attenuation accuracy (DSA to Amp)  $\pm(0.15\text{dB} + 3\% \times \text{Atten setting}) @ 1.7\sim 2.2\text{GHz}$
- 1.8V control logic compatible
- Programming modes - Serial
- Unique power-up state selection
- Two Functions application which are Dual channel Application (Tx-Rx) or Single Channel Application(2stage Amp and 2stage DSA )
- Lead-free/RoHS2-compliant QFN SMT Package



48-lead 7mm x 7mm x 0.9mm QFN

Figure 1. Package Type

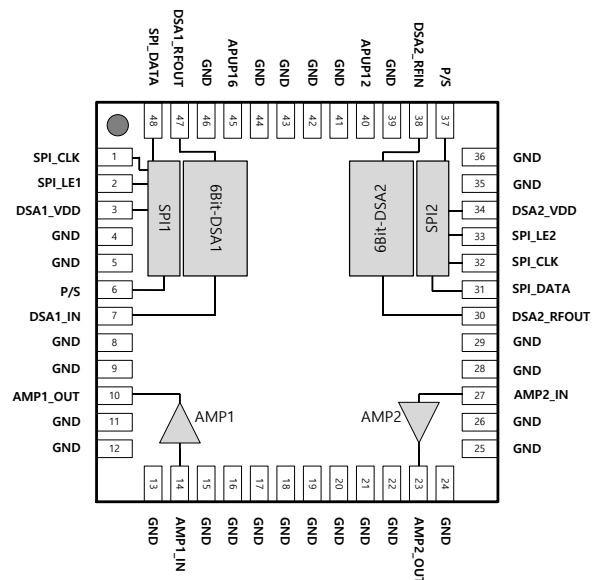


Figure 2. Functional Block Diagram

### Product Description

The BVA2182 is a digitally controlled variable gain amplifier (DVGA) in a 7x7mm QFN package, with a broadband frequency range of 0.5GHz to 3.8GHz and an operating  $V_{DD}$  of 5.0V at 170mA.

BVA2182 is high performance and high dynamic range makes it ideally suited for use in WCDMA/LTE wireless infrastructure point-to-point and other demanding wireless applications.

The BVA2182 is an integration of two high performance digital 6-step attenuator (DSA) that provides a 31.5 dB attenuation range in 0.5 dB steps, and high linearity broadband gain block amplifiers featuring high ACLR and P1.

The BVA2182 digital control interface supports serial programming of the attenuator, and includes the ability to define the initial attenuation state at power-up.

The BVA2182 is integrated of two gain blocks (AMP1, AMP2), a digital step attenuator(DSA1,DSA2). Implementation requires only a few external components, such as DC blocking capacitors on the Input and Output pins, plus a bypass capacitor and a RF choke for the Output port. The BVA2182 is composed of Amp1 + DSA1 + DSA2 + Amp2. In some case, It can be use with a dual path such as Amp1 + DSA1 and DSA2 + Amp2 .

### Application

- Base station/Repeater Infrastructure
- LTE/WCDMA/CDMA Wireless infrastructure and other high performance RF application
- Commercial/Industrial/Military Wireless system
- General purpose Wireless

Table 1. Electrical Specifications<sup>1</sup>

Parameter		Condition	Min	Typ	Max	Unit
Operational Frequency Range			500		3800	MHz
Gain		ATT = 0dB, at 1900MHz		33.5		dB
Attenuation Control range		0.5dB step		0.31.5		dB
Attenuation Step				31.5		dB
Attenuation Accuracy	>0.6GHz-1GHz	Any bit or bit combination	±(0.15dB + 2% of atten setting)			dB
	>1.6GHz-2.2GHz		±(0.15dB + 3% of atten setting)			
	>2.2GHz-2.8GHz		±(0.15dB + 5% of atten setting)			
	>3.3GHz-3.8GHz		±(0.15dB + 10% of atten setting)			
Return loss (input or output port)	Input Return Loss	ATT = 0dB		15.8		dB
	Output Return Loss			18.7		
Output Power for 1dB Compression		ATT = 0dB , at 1900MHz		21.2		dBm
Output Third Order Intercept Point		ATT = 0dB, at 1900MHz Pout= +5dBm/tone Δf = 1 MHz.		38.2		dBm
Noise Figure		ATT = 0dB, at 1900MHz		1.6		dB
Switching time		50% CTRL to 90% or 10% RF		500	800	ns
Supply voltage	DSA		2.7		5.5	V
	AMP			5		V
Supply Current		MCM(AMP1+DSA+AMP2)		170		mA
Control Interface		Serial mode		6		Bit
Impedance				50		Ω

1. Device performance \_ measured on a BeRex Evaluation board at 25°C, 50 Ω system, VDD=+5.0V, measure on Evaluation Board (AMP1 to DSA and AMP2)  
 2. Gain measured with a Pi 3dB Pad in Application circuit on Evaluation board

## DUAL DIGITAL VARIABLE GAIN AMPLIFIER

0.5GHz — 3.8GHz

**Table 2. Typical RF Performance<sup>1</sup>**

Parameter	Frequency												Unit
	Low Band Application (0.6-1GHz)			Medium Band Application (1.7-2.2GHz)			High Band Application (2.3-2.8GHz)			High Band Application (3.3-3.8GHz)			Band
	0.6	0.8	1	1.7	1.95	2.2	2.3	2.55	2.8	3.3	3.5	3.8	GHz
Gain <sup>2</sup>	33.5	33.3	32.7	33.9	33.5	32.4	33.5	33.1	32	32	30.8	30.2	dB
S11	-16.1	-17	-15.2	-14.3	-15.8	-11.2	-13.3	-16.9	-17	-15.3	-21.3	-29.3	dB
S22	-26.2	-40	-38.7	-14	-18.7	-24.9	-17.9	-18.7	-15.9	-10	-7.7	-6.5	dB
OIP3 <sup>3</sup>	37.8	38.1	37.7	38.1	38.2	38.4	38	38.2	38.4	37.5	38.7	39.2	dBm
P1dB	21.3	21.4	21.5	21.3	21.2	21.2	20.6	20.8	20.3	19.2	18.9	18.4	dBm
N.F	1.4	1.3	1.5	1.3	1.6	1.8	1.7	1.7	1.8	2	2.2	2.4	dB

1. Device performance \_ measured on a BeRex evaluation board at 25°C, V<sub>DD</sub>=+5.0V, 50 Ω system. measure on Evaluation Board (DSA to AMP).

2. OIP3 \_ measured with two tones at an output of +5 dBm per tone separated by 1 MHz.

3. Gain measured with a 7dB,3dB,2dB pi Pad in Application circuit on Evaluation board .(refer to table 11,13,15)

**Table 3. Absolute Maximum Ratings**

Parameter	Condition	Min	Typ	Max	Unit
Supply Voltage(V <sub>DD</sub> )	MCM(AMP1+DSA1+DSA2+AMP2)	-0.3		5.5	V
Supply Current	MCM(AMP1+DSA1+DSA2+AMP2)			380	mA
Digital input voltage	DSA	-0.3		3.6	V
Maximum input power	MCM(AMP1+DSA1+DSA2+AMP2)			+20	dBm
Storage Temperature	MCM(AMP1+DSA1+DSA2+AMP2)	-55		150	°C
Junction Temperature	MCM(AMP1+DSA1+DSA2+AMP2)			220	°C

Operation of this device above any of these parameters may result in permanent damage.

**Table 4. Recommended Operating Conditions**

Parameter	Condition	Min	Typ	Max	Unit
Bandwidth	MCM(AMP1+DSA1+DSA2+AMP2)	500		3800	MHz
Supply Voltage(V <sub>DD</sub> )	MCM(AMP1,AMP2)		5		V
	MCM(DSA1,DSA2)	2.7		5.5	V
Control Voltage	Digital input high	1.17		3.6	V
	Digital input low	-0.3		0.6	V
I <sub>c</sub> @(V <sub>DD</sub> =5V)	MCM(AMP1+DSA1+DSA2+AMP2)		170		mA
Operating Temperature	MCM(AMP1+DSA1+DSA2+AMP2)	-40		105	°C

### Programming Options

BVA2182 can be programmed using serial interface. Serial mode is P/S Pin pulling it to a voltage logic High.

#### Serial Control Mode

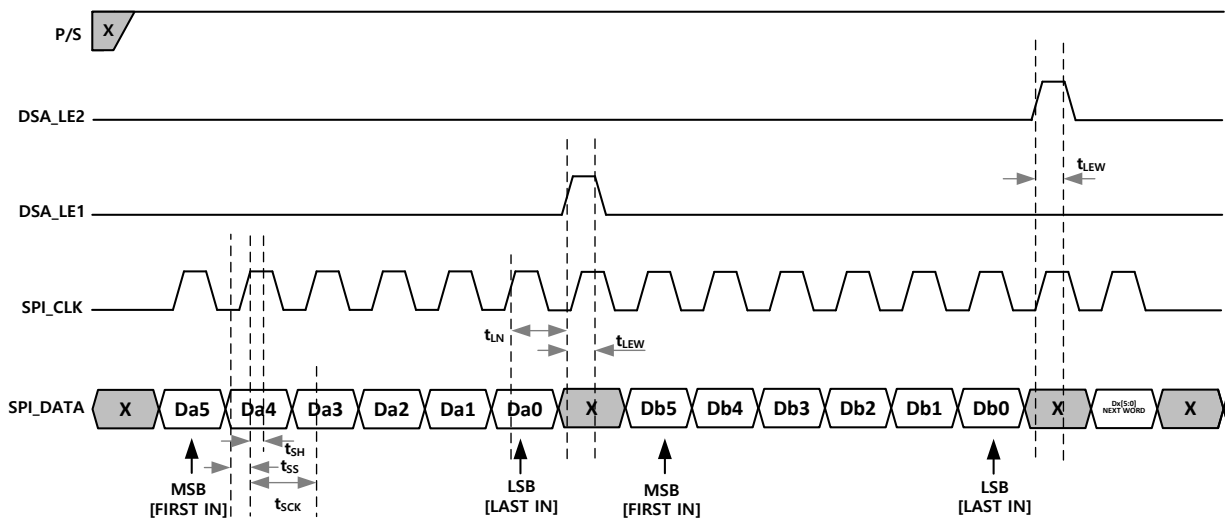
The serial interface is a 6 bit shift register to shift in the data MSB (Da5,Db5) first. It is controlled by three CMOS-compatible signals: SPI\_DATA, SPI\_Clock, and Latch Enable (DSA\_LE1, DSA\_LE2). DSA1 and DSA2 can operate independently and can be controlled at the same time through single SPI\_DATA and single SPI\_CLOCK.

Table 5. 6-Bit Serial Word Sequence

Da5	DSA1 Attenuation 16dB Control Bit
Da4	DSA1 Attenuation 8dB Control Bit
Da3	DSA1 Attenuation 4dB Control Bit
Da2	DSA1 Attenuation 2dB Control Bit
Da1	DSA1 Attenuation 1dB Control Bit
Da0	DSA1 Attenuation 0.5dB Control Bit

Db5	DSA2 Attenuation 16dB Control Bit
Db4	DSA2 Attenuation 8dB Control Bit
Db3	DSA2 Attenuation 4dB Control Bit
Db2	DSA2 Attenuation 2dB Control Bit
Db1	DSA2 Attenuation 1dB Control Bit
Db0	DSA2 Attenuation 0.5dB Control Bit

Figure 3. Serial Mode Resister Timing Diagram



The BVA2182 has a 4-wire serial peripheral interface (SPI): serial data input (SPI\_DATA), clock (SPI\_CLK), and latch enable (LE1,LE2). The serial control interface is activated when P/S is set to HIGH.

In serial mode, the 6-bit Data is clocked MSB first on the rising CLK edges into the shift register and then LE must be toggled High to latch the new attenuation state into the device. LE must be set to low to clock new 6-bit data into the shift register because CLK is masked to prevent the attenuator value from changing if LE is kept High (see Figure 3 and Table 8).

Table 6. Serial Interface Timing Specifications

Symbol	Parameter	Min	Typ	Max	Unit
$f_{CLK}$	Serial data clock frequency			10	MHz
$t_{SCK}$	Minimum serial period	70			
$t_{SS}$	Serial Data setup time	10			
$t_{SH}$	Serial Data hold time	10			
$t_{LN}$	LE setup time	10			
$t_{LEW}$	Minimum LE pulse width	30			
$t_{LES}$	Minimum LE pulse spacing		600		

Table 7. Mode Selection

P/S	Control Mode
LOW	Parallel
HIGH	Serial

**Table 8. Truth Table for Serial Control Word**

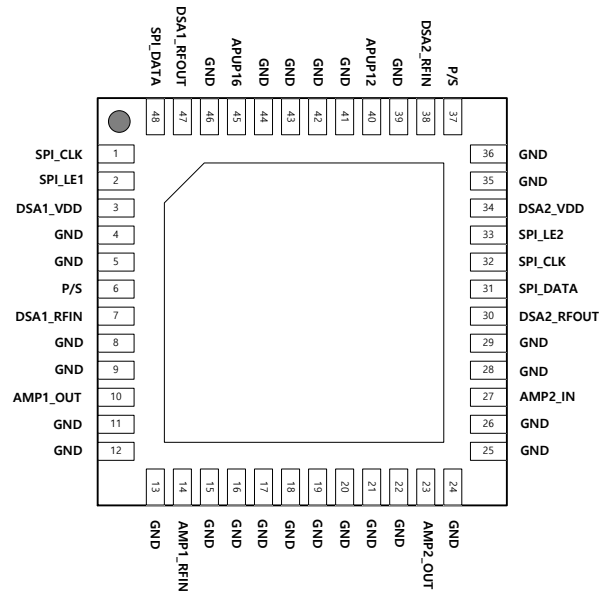
Channel 1 Digital Control Input						Attenuation (dB)
Da5 (MSB)	Da4	Da3	Da2	Da1	Da0 (LSB)	
0	0	0	0	0	0	0 (Reference)
0	0	0	0	0	1	0.5
0	0	0	0	1	0	1
0	0	0	1	0	0	2
0	0	1	0	0	0	4
0	1	0	0	0	0	8
1	0	0	0	0	0	16
1	1	1	1	1	1	31.5

Channel 2 Digital Control Input						Attenuation (dB)
Db5 (MSB)	Db4	Db3	Db2	Db1	Db0 (LSB)	
0	0	0	0	0	0	0 (Reference)
0	0	0	0	0	1	0.5
0	0	0	0	1	0	1
0	0	0	1	0	0	2
0	0	1	0	0	0	4
0	1	0	0	0	0	8
1	0	0	0	0	0	16
1	1	1	1	1	1	31.5

**Table 9. Power-UP Programming Truth Table**

Attenuation state	APUP12	APUP16
28 dB	1	1
16 dB	0	1
12 dB	1	0
Reference Gain	0	0

**Figure 4. Pin Configuration(Top View)**



**Table 10. Pin Description**

Pin	Pin name	Description
4,5,8,9,11,12,13,15,16,17,18,19,20,21,22,24,25,26,28,29,30,31,32,33,34,36,39,41,42,43,44,46	GND	Ground
1,32	SPI_CLK	Serial interface clock input
2	SPI_LE1	DSA1 Latch Enable input
3	DSA1_VDD	DSA Supply voltage (nominal 3.3V)
34	DSA2_VDD	DSA Supply voltage (nominal 3.3V)
6,37	P/S <sup>1</sup>	Parallel/Serial mode select
7	DSA1_RFIN	RF port (DSA1 RF input)
10	AMP1_OUT	Amplifier1 Supply Voltage & RF output
14	AMP1_IN	Amplifier1 RF input
23	AMP2_OUT	Amplifier2 Supply Voltage & RF output
27	AMP2_IN	Amplifier2 RF input
30	DSA2_RFOUT	RF port (DSA2 RF output)
31,48	SPI_DATA	Serial interface data input
33	SPI_LE2	DSA2 Latch Enable input
38	DSA2_RFIN	RF port (DSA2 RF input)
40	APUP12 <sup>2</sup>	Power-up selection bit 1(12dB)
45	APUP16 <sup>2</sup>	Power-up selection bit 2(16dB)
47	DSA1_RFOUT	RF port (DSA1 RF output)

Note: 1. P/S pin must be applied 1.17~3.6V, when use the serial mode.  
2. APUP12,16 pin must be applied 1.17~3.6V, when use the function with Power up Attenuation.

## DUAL DIGITAL VARIABLE GAIN AMPLIFIER

0.5GHz — 3.8GHz

### Typical RF Performance Plot - BVA2182 EVK - PCB (Application Circuit: 0.6-1GHz)

Typical Performance Data @ 25°C and AMP\_V<sub>DD</sub> = 5V, DSA\_V<sub>DD</sub> = 3.3V unless otherwise noted and Application Circuit refer to Table 11.

Table 11. Application Circuit : 0.6 - 1GHz

Schematic Diagram		BOM		Remark
Ref	Size	Value		
C3	0402	15nH		
C2	0402	200pF		
L2	0402	33nH		
C25	0402	200pF		
C22	0402	NC		
C23	0402	100pF		
C24	0402	1uF		
C16	0402	200pF		
C15	0402	43 ohm		7dB Pad
C17	0402	130 ohm		
C18	0402	130 ohm		
C14	0402	200pF		
C11	0402	15nH		
C9	0402	200pF		
C10	0402	NC		
L1	0402	33nH		
C37	0402	200pF		
C7	0402	100pF		
C8	0402	1uF		
C20	0402	68pF		LC Filter
L4	0402	100nH		
C19	0402	22pF		
C12	0402	22pF		LC Filter
L3	0402	100nH		
C13	0402	68pF		
R15	0402	0 ohm		
C44	0402	NC		
R8	0402	0 ohm		
R9	0402	10k ohm		
R10	0402	10k ohm		
R11	0402	0 ohm		
R14	0402	0 ohm		
R13	0402	10k ohm		
R12	0402	10k ohm		
C41	0402	100pF		
C42	0402	100pF		
C45	0402	NC		

NOTE: C1,C38 is 0ohm or Copper  
Any other Ref.Des(Power Supply Block), refer to table 19.

### Typical RF Performance Plot - BVA2182 EVK - PCB (Application Circuit: 0.6-1GHz)

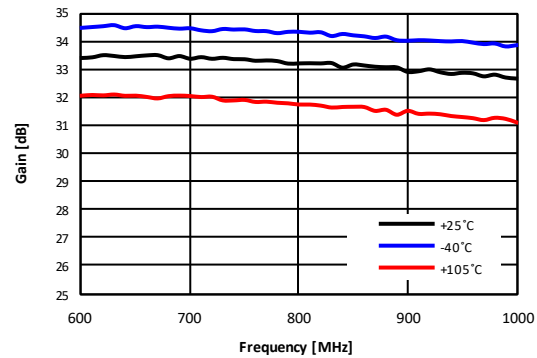
Typical Performance Data @ 25°C and AMP\_VDD = 5V, DSA\_VDD = 3.3V unless otherwise noted and Application Circuit refer to Table 11.

**Table 12. Typical RF Performance**

parameter	Typical Performance			Units
	0.6	0.8	1.0	
Frequency	0.6	0.8	1.0	GHz
Gain <sup>1</sup>	33.5	33.3	32.7	dB
S11	-16.1	-17.0	-15.2	dB
S22	-26.2	-40.0	-38.7	dB
OIP3 <sup>2</sup>	37.8	38.1	37.7	dBm
P1dB	21.3	21.4	21.5	dBm
Noise Figure	1.4	1.3	1.5	dB

1. Gain measured with 7dB Attenuation pi Pad between DSA1 and DSA2(Refer to Table11)  
 2. OIP3 measured with two tones at an output of 5 dBm per tone separated by 1 MHz.

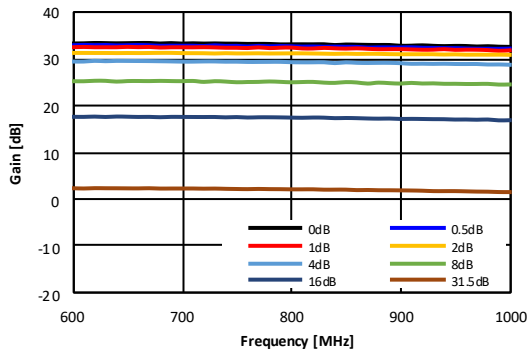
**Figure 5. Gain vs. Frequency**  
 over Temperature(DSA1,2 Att setting 0dB)



\*Gain measured with 7dB Attenuation pi Pad between DSA1 and DSA2(Refer to Table11)

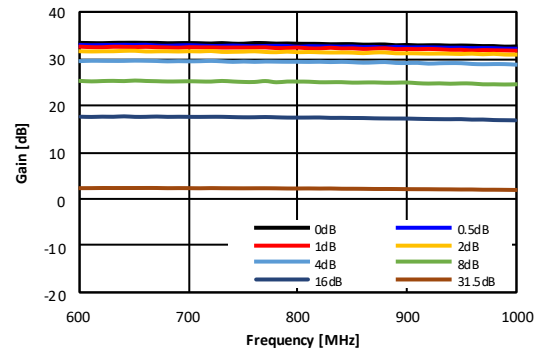
**Figure 6. Gain vs Attenuation Settings**

over Major Attenuation Setting(DSA1 Att Control, DSA2 Att setting 0dB)



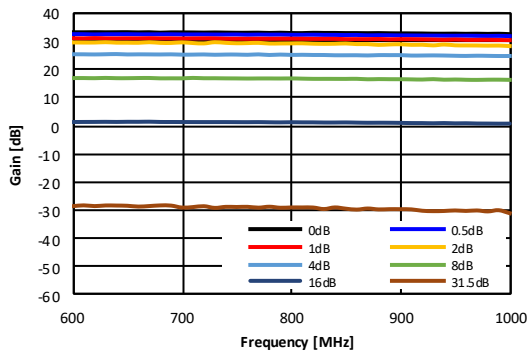
**Figure 7. Gain vs Attenuation Settings**

over Major Attenuation Setting(DSA2 Att Setting 0dB, DSA1 Att Control)



**Figure 8. Gain vs Attenuation Settings**

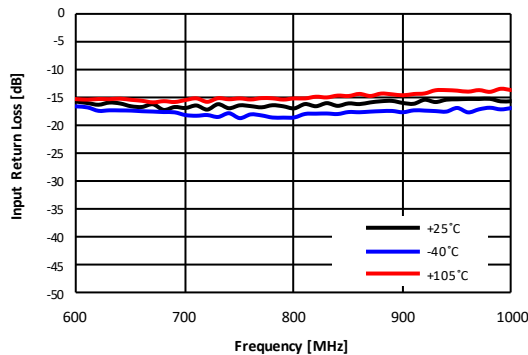
over Major Attenuation Setting(DSA1, DSA2 DUO Att Control, Attsettingx2)



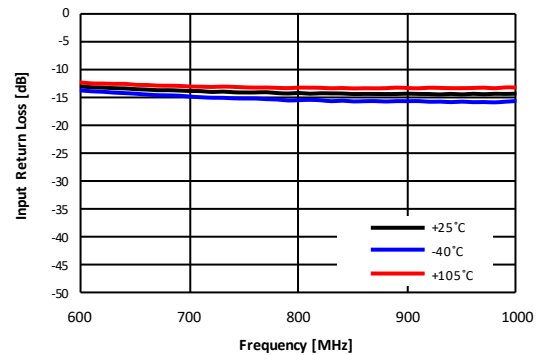
### Typical RF Performance Plot - BVA2182 EVK - PCB (Application Circuit: 0.6-1GHz)

Typical Performance Data @ 25°C and AMP\_V<sub>DD</sub> = 5V, DSA\_V<sub>DD</sub> = 3.3V unless otherwise noted and Application Circuit refer to Table 11.

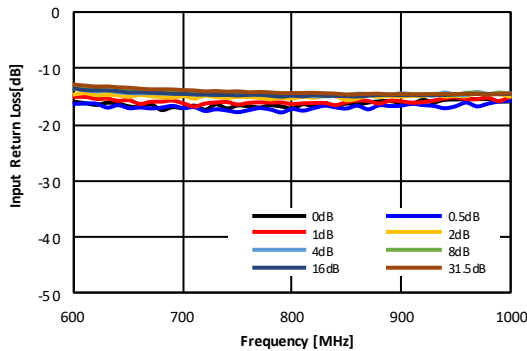
**Figure 9. Input Return Loss vs Frequency**  
over Temperature(DSA1,2 Att Setting 0dB)



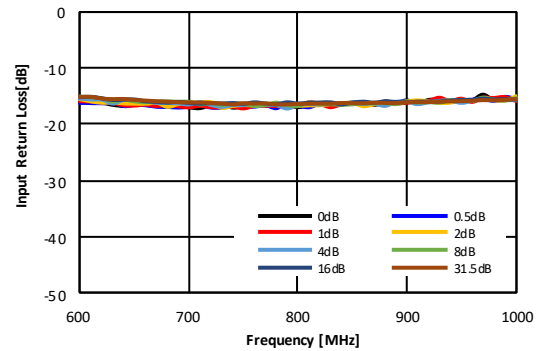
**Figure 10. Input Return Loss vs Frequency**  
over Temperature(DSA1, DSA2 DUO Att Control, Attsetting 31.5dB)



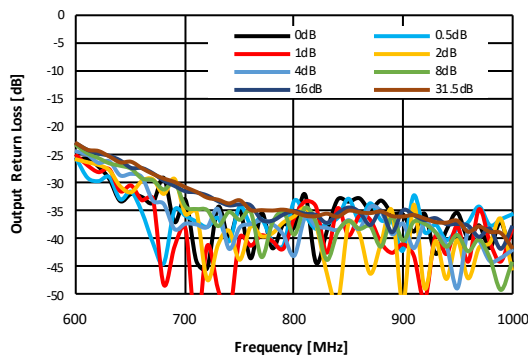
**Figure 11. Input Return Loss vs Frequency**  
over Major Attenuation Setting(DSA1 Att Control, DSA2 Att Setting 0dB)



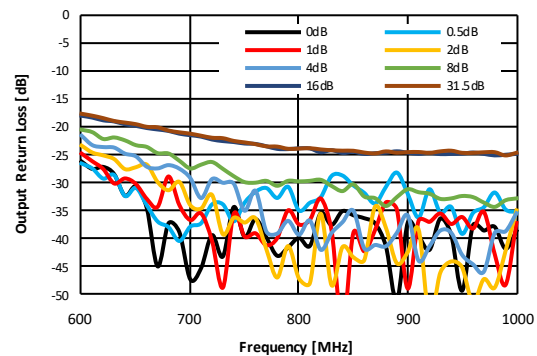
**Figure 12. Input Return Loss vs Frequency**  
over Major Attenuation Setting(DSA2 Att Control, DSA1 Att Setting 0dB)



**Figure 13. Output Return Loss vs Frequency**  
over Temperature(DSA1,2 Att Setting 0dB)



**Figure 14. Output Return Loss vs Frequency**  
over Temperature(DSA1, DSA2 DUO Att Control, Attsetting 31.5dB)

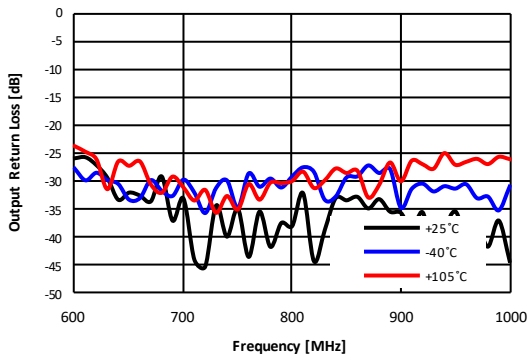




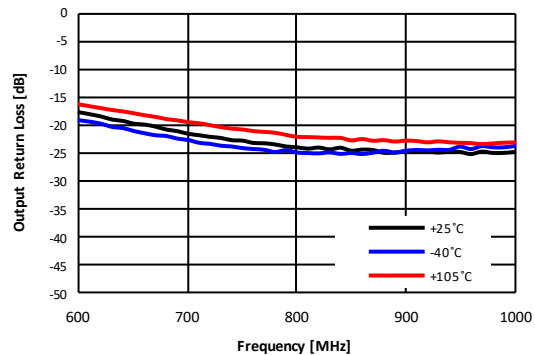
### Typical RF Performance Plot - BVA2182 EVK - PCB (Application Circuit: 0.6-1GHz)

Typical Performance Data @ 25°C and AMP\_V<sub>DD</sub> = 5V, DSA\_V<sub>DD</sub> = 3.3V unless otherwise noted and Application Circuit refer to Table 11.

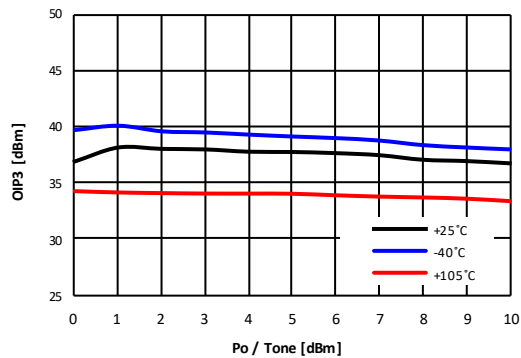
**Figure 15. Output Return Loss vs Frequency**  
over Major Attenuation Setting(DSA1 Att Control, DSA2 Att Setting 0dB)



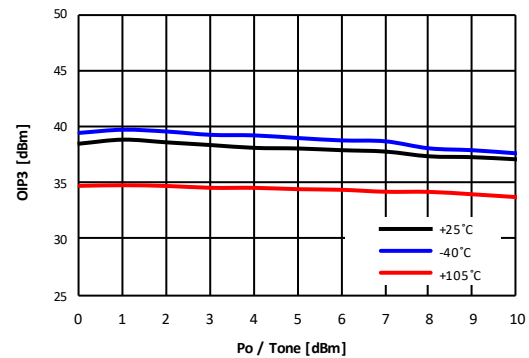
**Figure 16. Output Return Loss vs Frequency**  
over Major Attenuation Setting(DSA2 Att Control, DSA1 Att Setting 0dB)



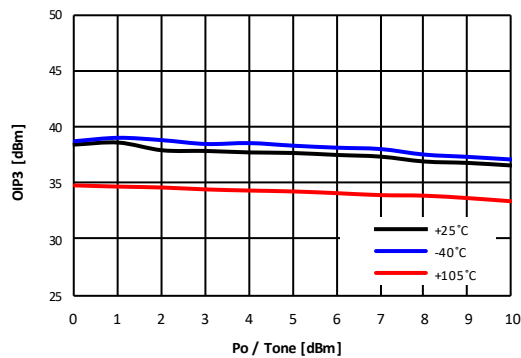
**Figure 17. OIP3 vs Output Power**  
over Temperature(@0.6GHz, DSA1,2 Att Setting 0dB)



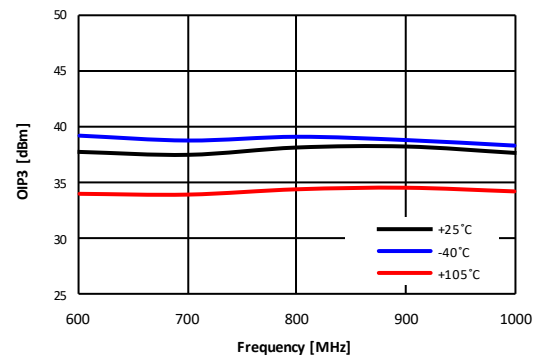
**Figure 18. OIP3 vs Output Power**  
over Temperature(@0.8GHz, DSA1,2 Att Setting 0dB)



**Figure 19. OIP3 vs Output Power**  
over Temperature(@1GHz, DSA1,2 Att Setting 0dB)



**Figure 20. OIP3 vs Frequency**  
over Temperature(DSA1,2 Att Setting 0dB)

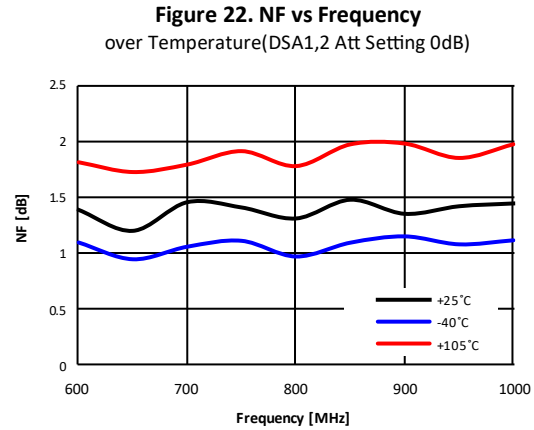
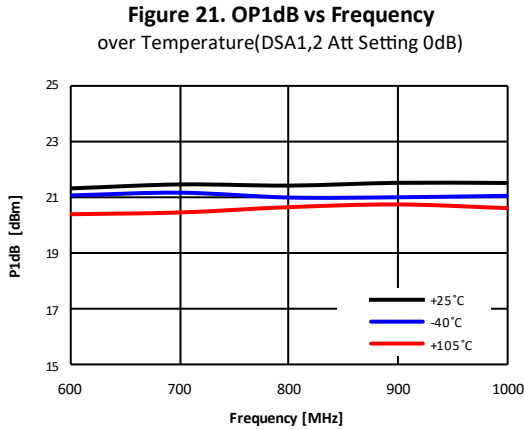


## DUAL DIGITAL VARIABLE GAIN AMPLIFIER

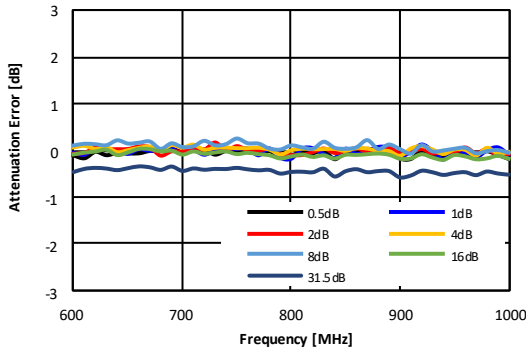
0.5GHz — 3.8GHz

### Typical RF Performance Plot - BVA2182 EVK - PCB (Application Circuit: 0.6-1GHz)

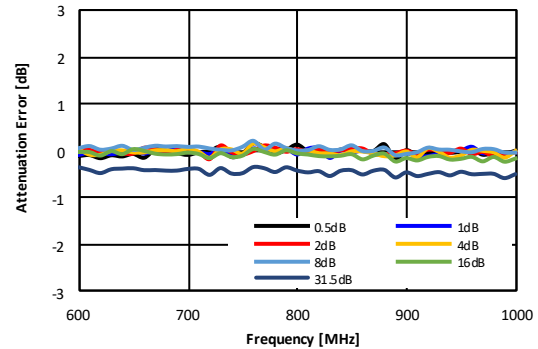
Typical Performance Data @ 25°C and AMP\_V<sub>DD</sub> = 5V, DSA\_V<sub>DD</sub> = 3.3V unless otherwise noted and Application Circuit refer to Table 11.



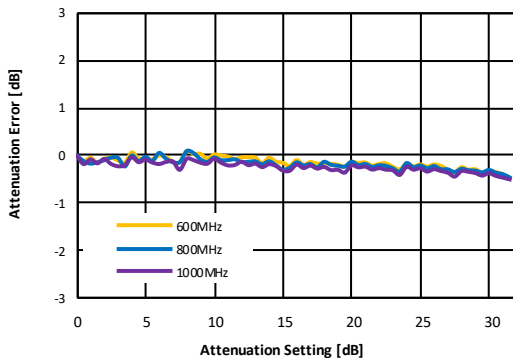
**Figure 23. Attenuation Error vs Frequency**  
over Major Attenuation Setting(DSA1 Control, DSA2 Att Setting 0dB @+25°C)



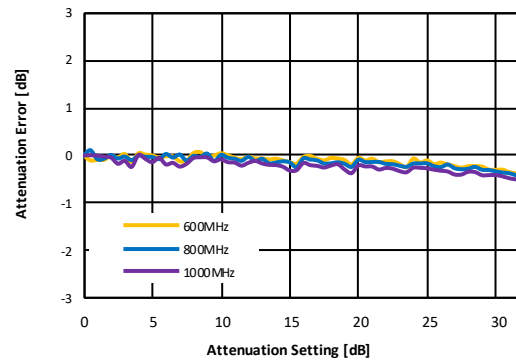
**Figure 24. Attenuation Error vs Frequency**  
over Major Attenuation Setting(DSA2 Control, DSA1 Att Setting 0dB @+25°C)



**Figure 25. Attenuation Error vs Attenuation Setting**  
over Major Frequency(DSA1 Control, DSA2 Att Setting 0dB)



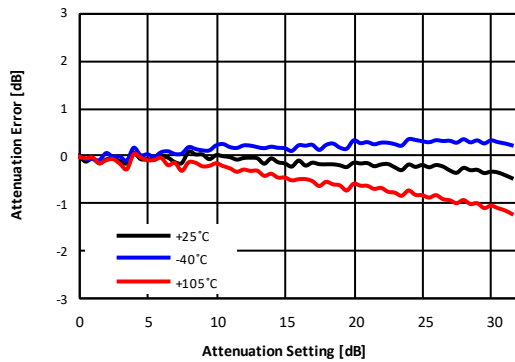
**Figure 26. Attenuation Error vs Attenuation Setting**  
over Major Frequency(DSA2 Control, DSA1 Att Setting 0dB)



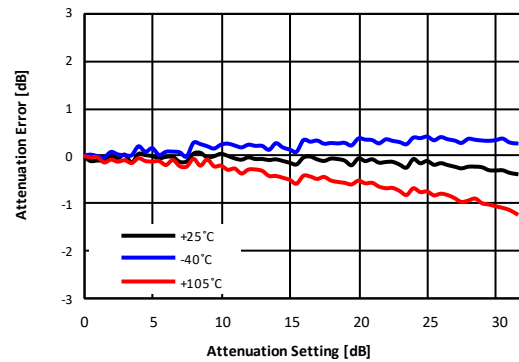
### Typical RF Performance Plot - BVA2182 EVK - PCB (Application Circuit: 0.6-1GHz)

Typical Performance Data @ 25°C and AMP\_VDD = 5V, DSA\_VDD = 3.3V unless otherwise noted and Application Circuit refer to Table 11.

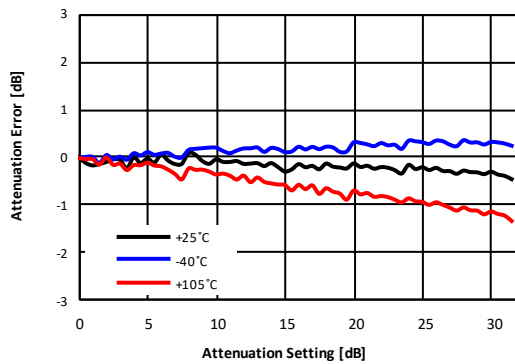
**Figure 27. Attenuation Error vs Attenuation Setting**  
over Temperature(@0.6GHz, DSA1 Control, DSA2 Att Setting 0dB)



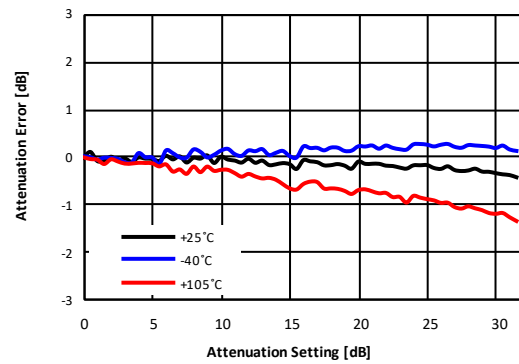
**Figure 28. Attenuation Error vs Attenuation Setting**  
over Temperature(@0.6GHz, DSA2 Control, DSA1 Att Setting 0dB)



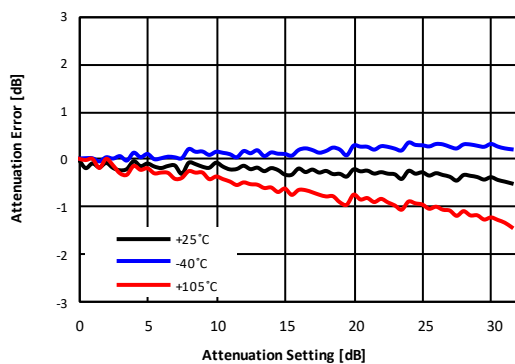
**Figure 29. Attenuation Error vs Attenuation Setting**  
over Temperature(@0.8GHz, DSA1 Control, DSA2 Att Setting 0dB)



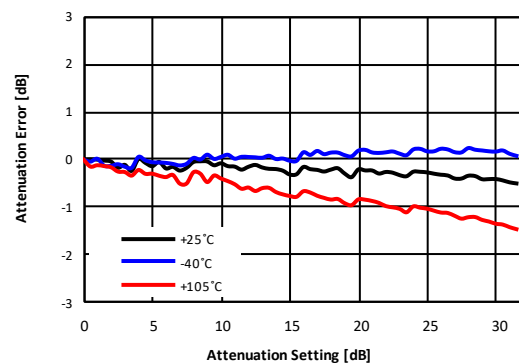
**Figure 30. Attenuation Error vs Attenuation Setting**  
over Temperature(@0.8GHz, DSA2 Control, DSA1 Att Setting 0dB)



**Figure 31. Attenuation Error vs Attenuation Setting**  
over Temperature(@1GHz, DSA1 Control, DSA2 Att Setting 0dB)



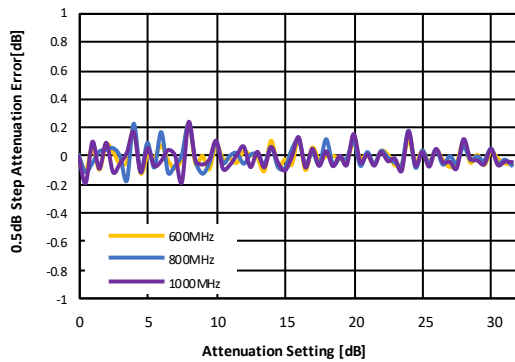
**Figure 32. Attenuation Error vs Attenuation Setting**  
over Temperature(@1GHz, DSA2 Control, DSA1 Att Setting 0dB)



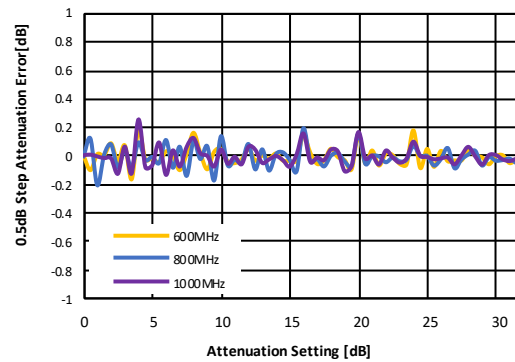
### Typical RF Performance Plot - BVA2182 EVK - PCB (Application Circuit: 0.6-1GHz)

Typical Performance Data @ 25°C and AMP\_VDD = 5V, DSA\_VDD = 3.3V unless otherwise noted and Application Circuit refer to Table 11.

**Figure 33. 0.5dB Step Attenuation vs Attenuation Setting**  
over Major Attenuation Setting(DSA1 Control, DSA2 Att Setting 0dB @+25°C)



**Figure 34. 0.5dB Step Attenuation vs Attenuation Setting**  
over Major Attenuation Setting(DSA2 Control, DSA1 Att Setting 0dB @+25°C)



## DUAL DIGITAL VARIABLE GAIN AMPLIFIER

### 0.5GHz — 3.8GHz

#### Typical RF Performance Plot - BVA2182 EVK - PCB (Application Circuit: 1.7-2.2GHz)

Typical Performance Data @ 25°C and AMP\_V<sub>DD</sub> = 5V, DSA\_V<sub>DD</sub> = 3.3V unless otherwise noted and Application Circuit refer to Table 13.

Table 13. Application Circuit : 1.7 - 2.2GHz

Schematic Diagram		BOM		Remark	
		Ref	Size		Value
		C3	0402	5.6nH	
		C2	0402	4pF	
		L2	0402	3.9nH	
		C25	0402	22pF	
		C22	0402	NC	
		C23	0402	22pF	
		C24	0402	1uF	
		C16	0402	1.2nH	
		C15	0402	18 ohm	3dB Pad
		C17	0402	300 ohm	
		C18	0402	300 ohm	
		C14	0402	1.2nH	
		C11	0402	5.6nH	
		C9	0402	4pF	
		C10	0402	NC	
		L1	0402	5.6nH	
		C37	0402	22pF	
		C7	0402	22pF	
		C8	0402	1uF	
		C20	0402	68pF	LC Filter
		L4	0402	100nH	
		C19	0402	22pF	
		C12	0402	22pF	LC Filter
		L3	0402	100nH	
		C13	0402	68pF	
R15	0402	0 ohm			
C44	0402	5pF			
R8	0402	0 ohm			
R9	0402	10k ohm			
R10	0402	10k ohm			
R11	0402	0 ohm			
R14	0402	0 ohm			
R13	0402	10k ohm			
R12	0402	10k ohm			
C41	0402	NC			
C42	0402	NC			
C45	0402	NC			

NOTE: C1, C38 is 0ohm or Copper  
Any other Ref.Des(Power Supply Block), refer to table 19.

### Typical RF Performance Plot - BVA2182 EVK - PCB (Application Circuit: 1.7-2.2GHz)

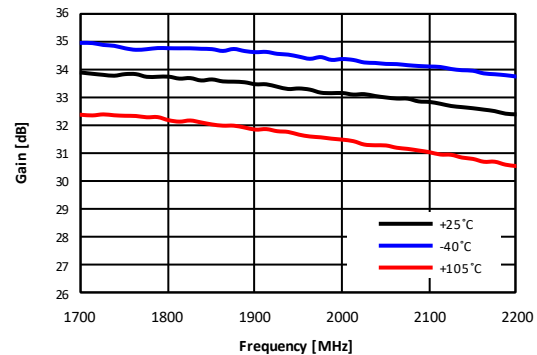
Typical Performance Data @ 25°C and AMP\_V<sub>DD</sub> = 5V, DSA\_V<sub>DD</sub> = 3.3V unless otherwise noted and Application Circuit refer to Table 13.

**Table 14. Typical RF Performance**

parameter	Typical Performance			Units
	1.7	1.95	2.2	
Frequency	1.7	1.95	2.2	GHz
Gain <sup>1</sup>	33.9	33.5	32.4	dB
S11	-14.3	-15.8	-11.2	dB
S22	-14.0	-18.7	-24.9	dB
OIP3 <sup>2</sup>	38.1	38.2	38.4	dBm
P1dB	21.3	21.2	21.2	dBm
Noise Figure	1.3	1.6	1.8	dB

1. Gain measured with 3dB Attenuation pi Pad between DSA1 and DSA2(Refer to Table13)  
 2. OIP3 measured with two tones at an output of 5 dBm per tone separated by 1 MHz.

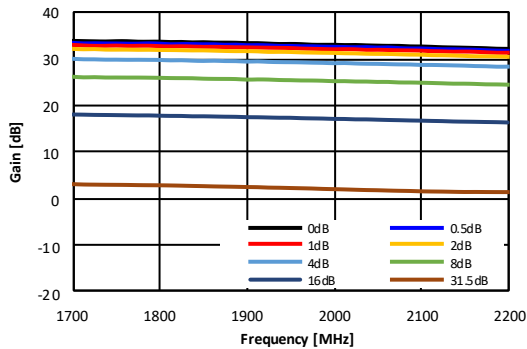
**Figure 35. Gain vs. Frequency over Temperature(DSA1,2 Att setting 0dB)**



\*Gain measured with 3dB Attenuation pi Pad between DSA1 and DSA2(Refer to Table13)

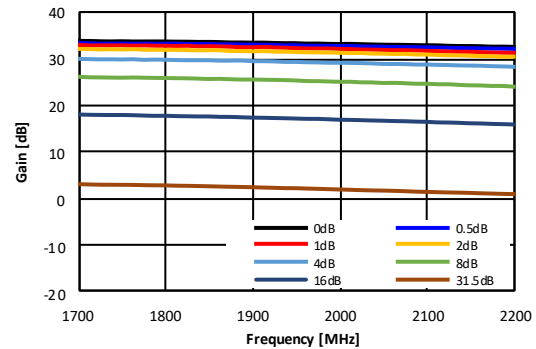
**Figure 36. Gain vs Attenuation Settings over Major Attenuation Setting(DSA1 Att Control, DSA2 Att setting 0dB)**

over Major Attenuation Setting(DSA1 Att Control, DSA2 Att setting 0dB)



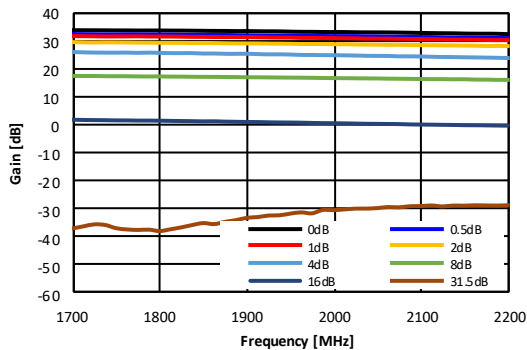
**Figure 37. Gain vs Attenuation Settings over Major Attenuation Setting(DSA2 Att Setting 0dB, DSA1 Att Control)**

over Major Attenuation Setting(DSA2 Att Setting 0dB, DSA1 Att Control)



**Figure 38. Gain vs Attenuation Settings over Major Attenuation Setting(DSA1, DSA2 DUO Att Control, Attsettingx2)**

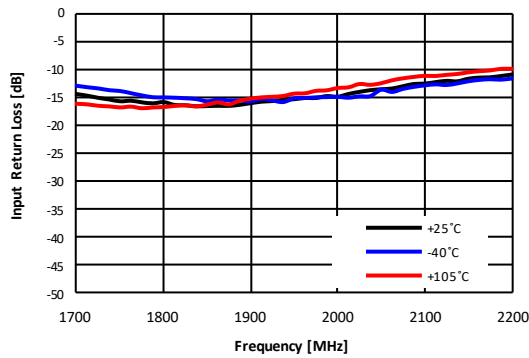
over Major Attenuation Setting(DSA1, DSA2 DUO Att Control, Attsettingx2)



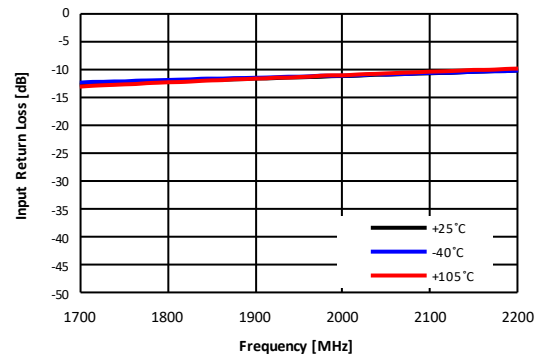
### Typical RF Performance Plot - BVA2182 EVK - PCB (Application Circuit: 1.7-2.2GHz)

Typical Performance Data @ 25°C and AMP\_V<sub>DD</sub> = 5V, DSA\_V<sub>DD</sub> = 3.3V unless otherwise noted and Application Circuit refer to Table 13.

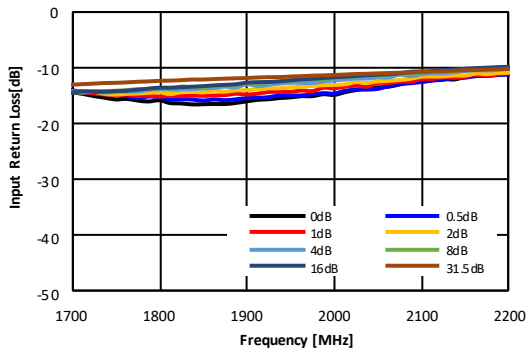
**Figure 39. Input Return Loss vs Frequency**  
over Temperature(DSA1,2 Att Setting 0dB)



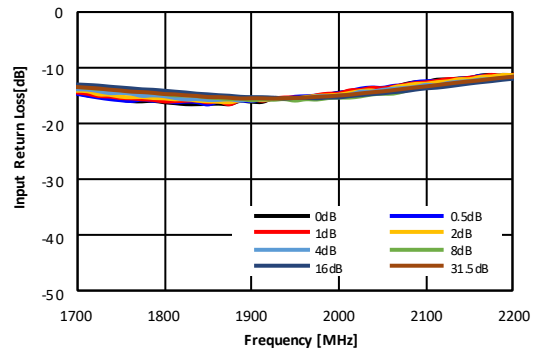
**Figure 40. Input Return Loss vs Frequency**  
over Temperature(DSA1, DSA2 DUO Att Control, Attsetting 31.5dB)



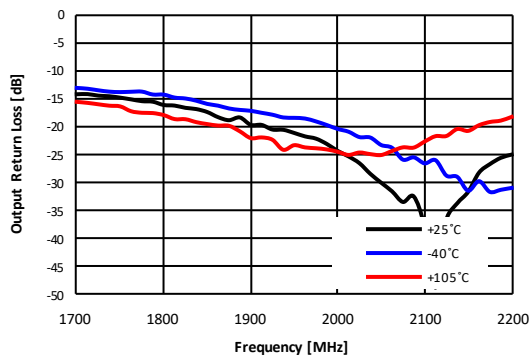
**Figure 41. Input Return Loss vs Frequency**  
over Major Attenuation Setting(DSA1 Att Control, DSA2 Att Setting 0dB)



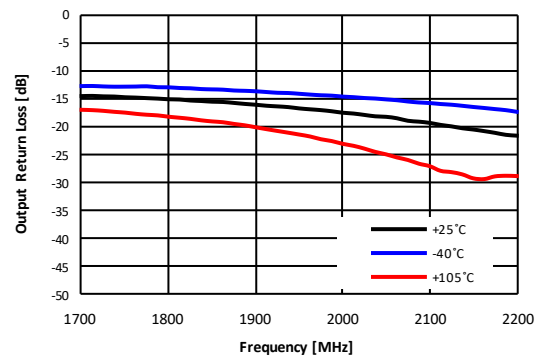
**Figure 42. Input Return Loss vs Frequency**  
over Major Attenuation Setting(DSA2 Att Control, DSA1 Att Setting 0dB)



**Figure 43. Output Return Loss vs Frequency**  
over Temperature(DSA1,2 Att Setting 0dB)

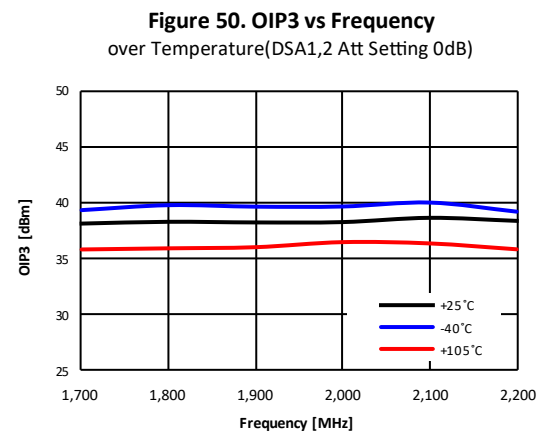
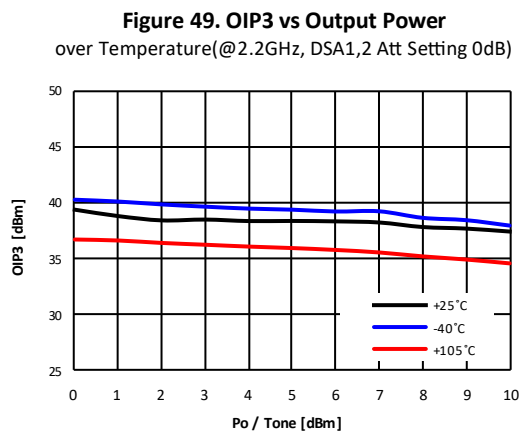
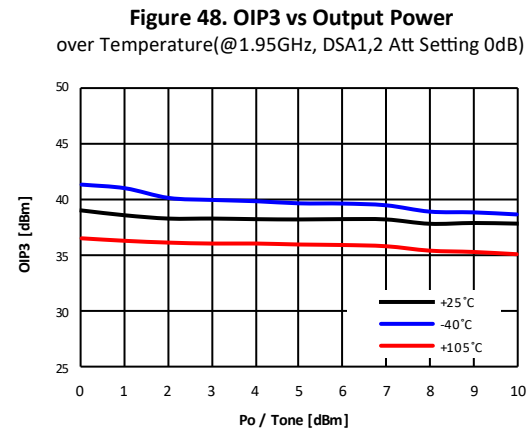
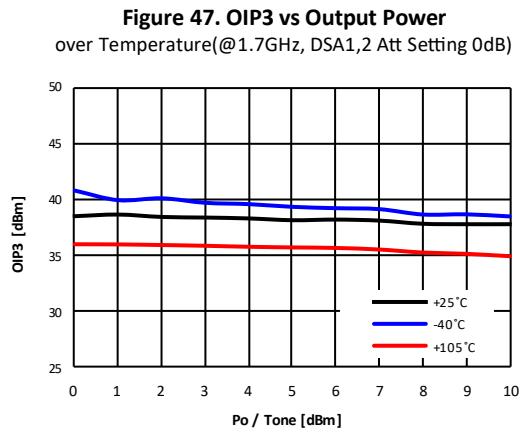
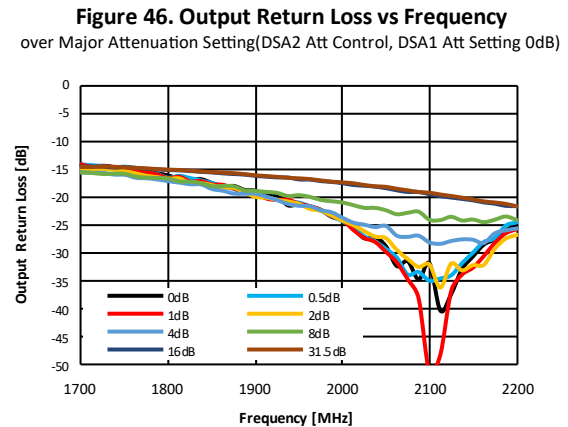
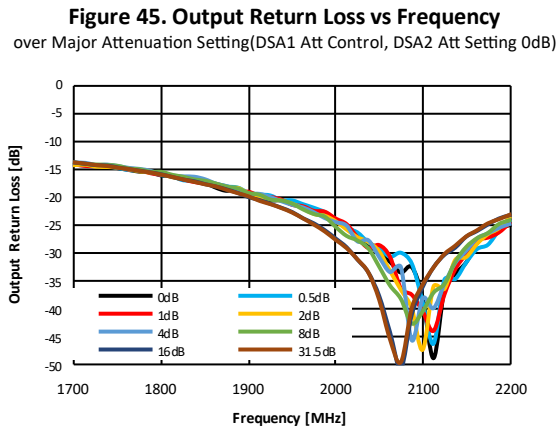


**Figure 44. Output Return Loss vs Frequency**  
over Temperature(DSA1, DSA2 DUO Att Control, Attsetting 31.5dB)



### Typical RF Performance Plot - BVA2182 EVK - PCB (Application Circuit: 1.7-2.2GHz)

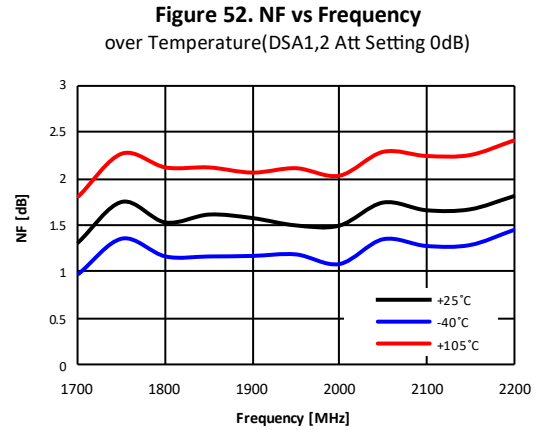
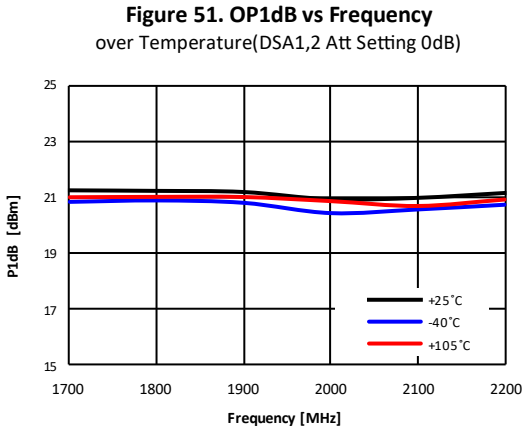
Typical Performance Data @ 25°C and AMP\_V<sub>DD</sub> = 5V, DSA\_V<sub>DD</sub> = 3.3V unless otherwise noted and Application Circuit refer to Table 13.



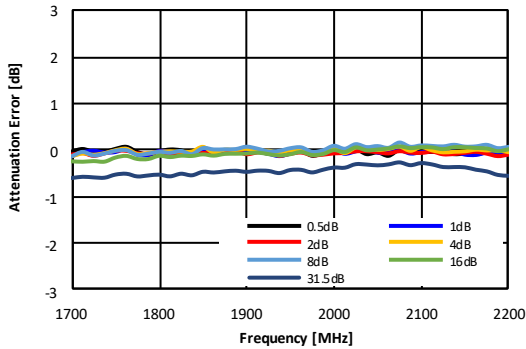


### Typical RF Performance Plot - BVA2182 EVK - PCB (Application Circuit: 1.7-2.2GHz)

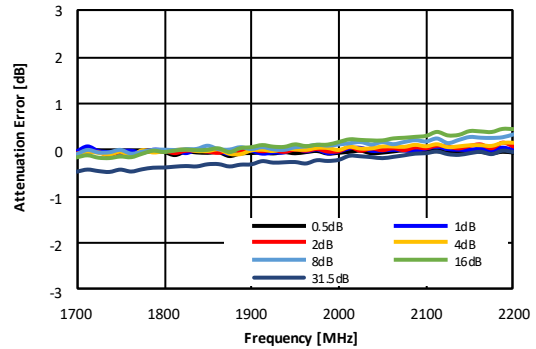
Typical Performance Data @ 25°C and AMP\_V<sub>DD</sub> = 5V, DSA\_V<sub>DD</sub> = 3.3V unless otherwise noted and Application Circuit refer to Table 13.



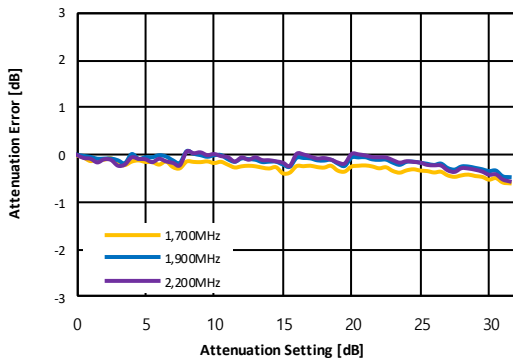
**Figure 53. Attenuation Error vs Frequency**  
over Major Attenuation Setting(DSA1 Control, DSA2 Att Setting 0dB @+25°C)



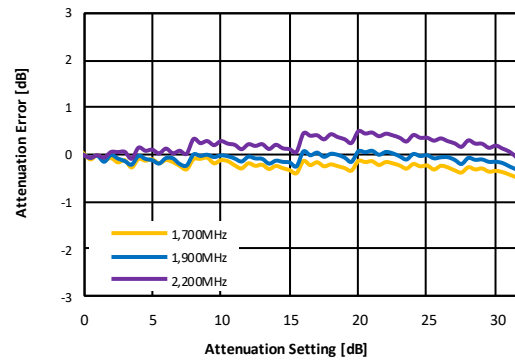
**Figure 54. Attenuation Error vs Frequency**  
over Major Attenuation Setting(DSA2 Control, DSA1 Att Setting 0dB @+25°C)



**Figure 55. Attenuation Error vs Attenuation Setting**  
over Major Frequency(DSA1 Control, DSA2 Att Setting 0dB)



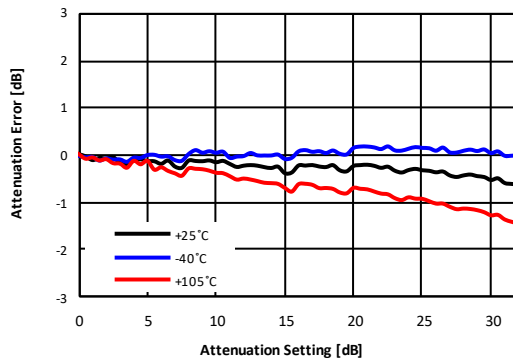
**Figure 56. Attenuation Error vs Attenuation Setting**  
over Major Frequency(DSA2 Control, DSA1 Att Setting 0dB)



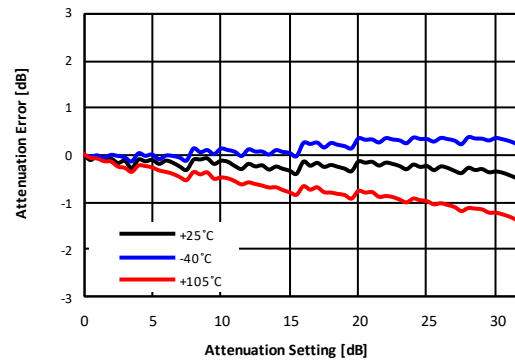
### Typical RF Performance Plot - BVA2182 EVK - PCB (Application Circuit: 1.7-2.2GHz)

Typical Performance Data @ 25°C and AMP\_VDD = 5V, DSA\_VDD = 3.3V unless otherwise noted and Application Circuit refer to Table 13.

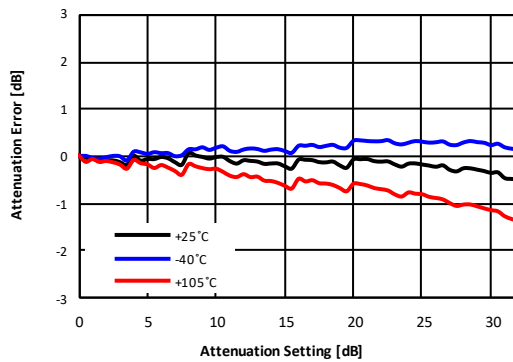
**Figure 57. Attenuation Error vs Attenuation Setting**  
over Temperature(@1.7GHz, DSA1 Control, DSA2 Att Setting 0dB)



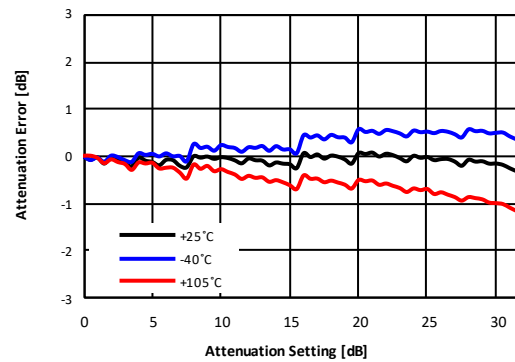
**Figure 58. Attenuation Error vs Attenuation Setting**  
over Temperature(@1.7GHz, DSA2 Control, DSA1 Att Setting 0dB)



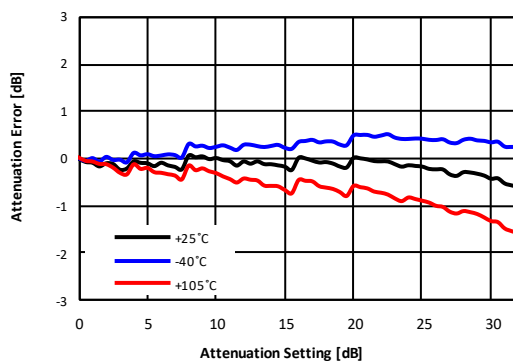
**Figure 59. Attenuation Error vs Attenuation Setting**  
over Temperature(@1.95GHz, DSA1 Control, DSA2 Att Setting 0dB)



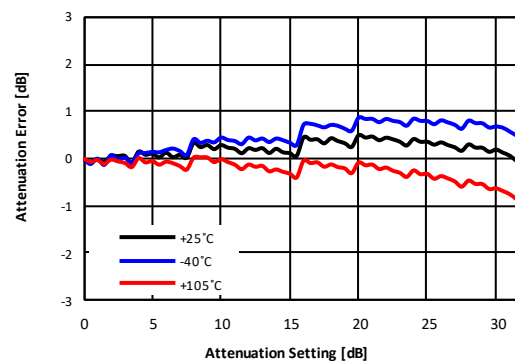
**Figure 60. Attenuation Error vs Attenuation Setting**  
over Temperature(@1.95GHz, DSA2 Control, DSA1 Att Setting 0dB)



**Figure 61. Attenuation Error vs Attenuation Setting**  
over Temperature(@2.2GHz, DSA1 Control, DSA2 Att Setting 0dB)



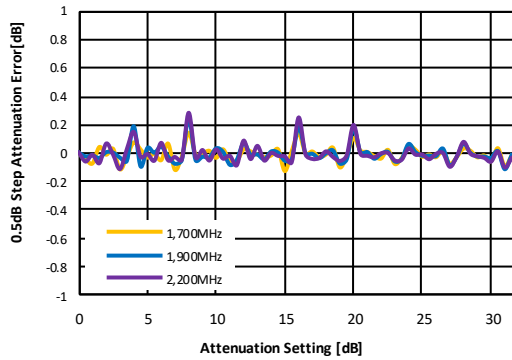
**Figure 62. Attenuation Error vs Attenuation Setting**  
over Temperature(@2.2GHz, DSA2 Control, DSA1 Att Setting 0dB)



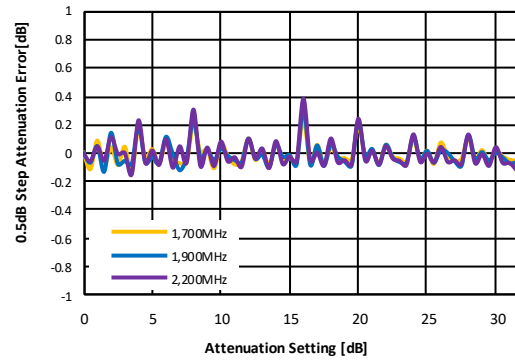
### Typical RF Performance Plot - BVA2182 EVK - PCB (Application Circuit: 1.7-2.2GHz)

Typical Performance Data @ 25°C and AMP\_VDD = 5V, DSA\_VDD = 3.3V unless otherwise noted and Application Circuit refer to Table 13.

**Figure 63. 0.5dB Step Attenuation vs Attenuation Setting**  
over Major Attenuation Setting(DSA1 Control, DSA2 Att Setting 0dB @+25°C)



**Figure 64. 0.5dB Step Attenuation vs Attenuation Setting**  
over Major Attenuation Setting(DSA2 Control, DSA1 Att Setting 0dB @+25°C)



## DUAL DIGITAL VARIABLE GAIN AMPLIFIER

### 0.5GHz — 3.8GHz

#### Typical RF Performance Plot - BVA2182 EVK - PCB (Application Circuit: 2.3-2.8GHz)

Typical Performance Data @ 25°C and AMP\_V<sub>DD</sub> = 5V, DSA\_V<sub>DD</sub> = 3.3V unless otherwise noted and Application Circuit refer to Table 15.

Table 15. Application Circuit : 2.3 - 2.8GHz

Schematic Diagram		BOM		Remark	
		Ref	Size		Value
		C3	0402	0.5pF	
		C2	0402	22pF	
		L2	0402	2.7nH	
		C25	0402	22pF	
		C22	0402	NC	
		C23	0402	22pF	
		C24	0402	1uF	
		C16	0402	22pF	
		C15	0402	12 ohm	2dB Pad
		C17	0402	430 ohm	
		C18	0402	430 ohm	
		C14	0402	22pF	
		C11	0402	NC	
		C9	0402	22pF	
		C10	0402	NC	
		L1	0402	3.6nH	
		C37	0402	22pF	
		C7	0402	22pF	
		C8	0402	1uF	
		C20	0402	68pF	LC Filter
		L4	0402	100nH	
		C19	0402	22pF	
		C12	0402	22pF	LC Filter
		L3	0402	100nH	
		C13	0402	68pF	
R15	0402	0 ohm			
C44	0402	NC			
R8	0402	0 ohm			
R9	0402	10k ohm			
R10	0402	10k ohm			
R11	0402	0 ohm			
R14	0402	0 ohm			
R13	0402	10k ohm			
R12	0402	10k ohm			
C41	0402	22pF			
C42	0402	22pF			
C45	0402	1uF			

NOTE: C1,C38 is 0ohm or Copper  
Any other Ref.Des(Power Supply Block), refer to table 19.

### Typical RF Performance Plot - BVA2182 EVK - PCB (Application Circuit: 2.3-2.8GHz)

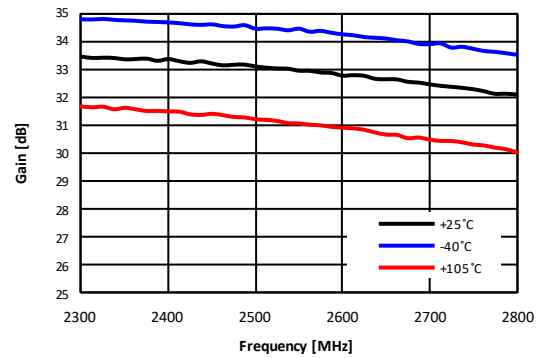
Typical Performance Data @ 25°C and AMP\_V<sub>DD</sub> = 5V, DSA\_V<sub>DD</sub> = 3.3V unless otherwise noted and Application Circuit refer to Table 15.

**Table 16. Typical RF Performance**

parameter	Typical Performance			Units
	2.3	2.55	2.8	
Frequency	2.3	2.55	2.8	GHz
Gain <sup>1</sup>	33.5	33.1	32.0	dB
S11	-13.3	-16.9	-17.0	dB
S22	-17.9	-18.7	-15.9	dB
OIP3 <sup>2</sup>	38.0	38.2	38.4	dBm
P1dB	20.6	20.8	20.3	dBm
Noise Figure	1.7	1.7	1.8	dB

1. Gain measured with 2dB Attenuation pi Pad between DSA1 and DSA2(Refer to Table15)  
 2. OIP3 measured with two tones at an output of 5 dBm per tone separated by 1 MHz.

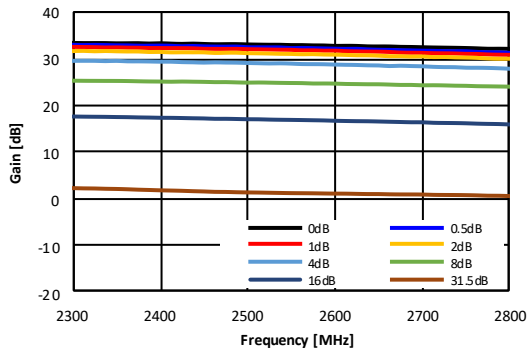
**Figure 65. Gain vs. Frequency over Temperature(DSA1,2 Att setting 0dB)**



\*Gain measured with 2dB Attenuation pi Pad between DSA1 and DSA2(Refer to Table15)

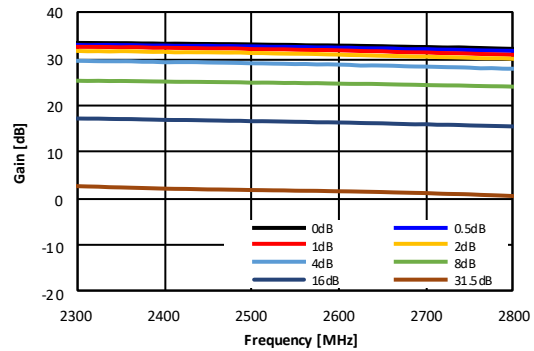
**Figure 66. Gain vs Attenuation Settings over Major Attenuation Setting(DSA1 Att Control, DSA2 Att setting 0dB)**

over Major Attenuation Setting(DSA1 Att Control, DSA2 Att setting 0dB)



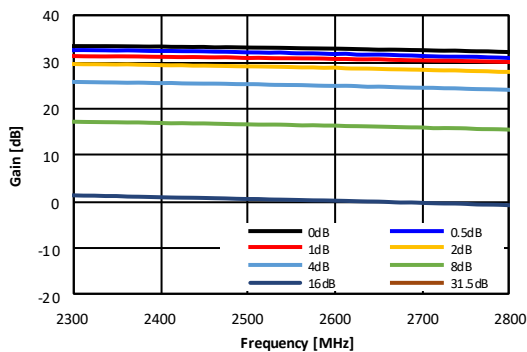
**Figure 67. Gain vs Attenuation Settings over Major Attenuation Setting(DSA2 Att Setting 0dB, DSA1 Att Control)**

over Major Attenuation Setting(DSA2 Att Setting 0dB, DSA1 Att Control)



**Figure 68. Gain vs Attenuation Settings over Major Attenuation Setting(DSA1, DSA2 DUO Att Control, Attsettingx2 dB)**

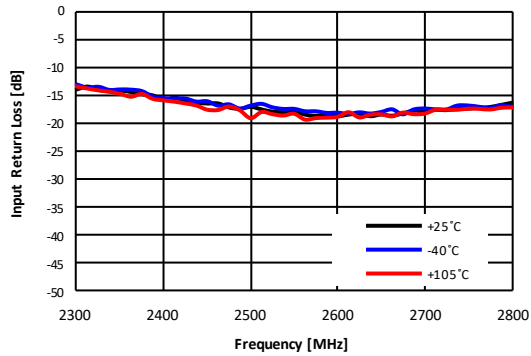
over Major Attenuation Setting(DSA1, DSA2 DUO Att Control, Attsettingx2 dB)



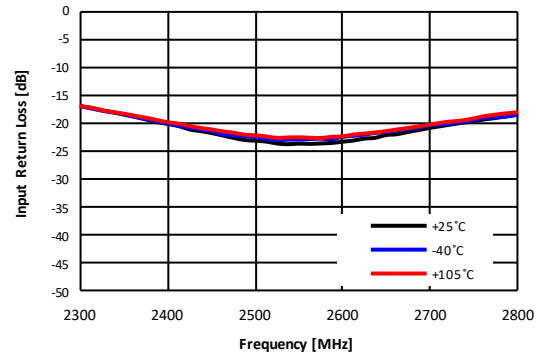
### Typical RF Performance Plot - BVA2182 EVK - PCB (Application Circuit: 2.3-2.8GHz)

Typical Performance Data @ 25°C and AMP\_V<sub>DD</sub> = 5V, DSA\_V<sub>DD</sub> = 3.3V unless otherwise noted and Application Circuit refer to Table 15.

**Figure 69. Input Return Loss vs Frequency**  
over Temperature(DSA1,2 Att Setting 0dB)

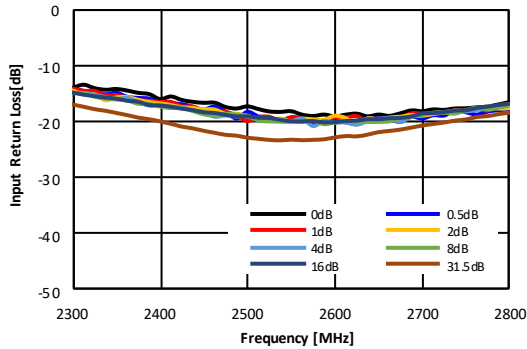


**Figure 70. Input Return Loss vs Frequency**  
over Temperature(DSA1, DSA2 DUO Att Control, Attsetting 31.5dB)

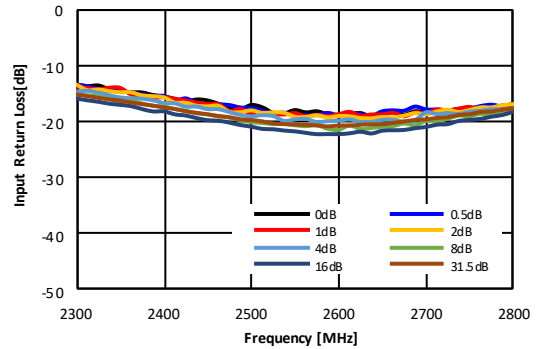


\*Att setting x2 means a total of 4dB DSA1 2dB and DSA2 2dB, when att setting is 2dB.

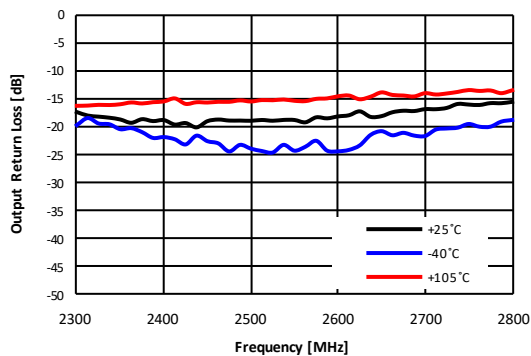
**Figure 71. Input Return Loss vs Frequency**  
over Major Attenuation Setting(DSA1 Att Control, DSA2 Att Setting 0dB)



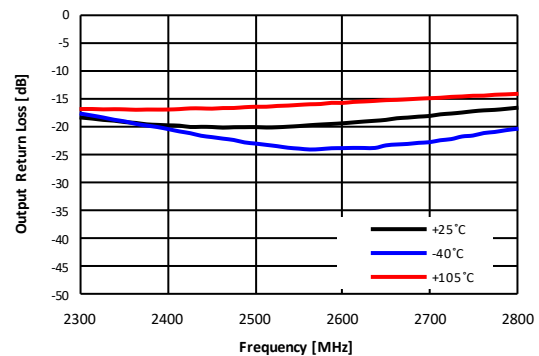
**Figure 72. Input Return Loss vs Frequency**  
over Major Attenuation Setting(DSA2 Att Control, DSA1 Att Setting 0dB)



**Figure 73. Output Return Loss vs Frequency**  
over Temperature(DSA1,2 Att Setting 0dB)



**Figure 74. Output Return Loss vs Frequency**  
over Temperature(DSA1, DSA2 DUO Att Control, Attsetting 31.5dB)



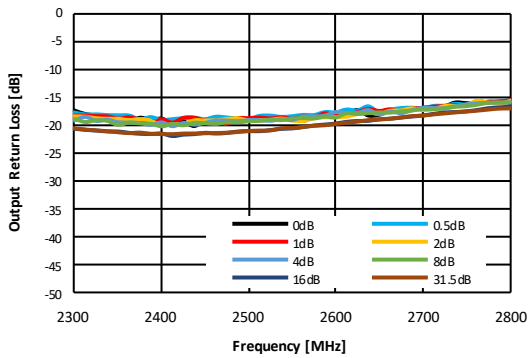
## DUAL DIGITAL VARIABLE GAIN AMPLIFIER

0.5GHz — 3.8GHz

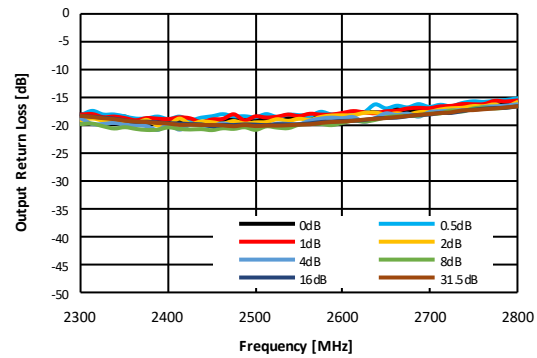
### Typical RF Performance Plot - BVA2182 EVK - PCB (Application Circuit: 2.3-2.8GHz)

Typical Performance Data @ 25°C and AMP\_V<sub>DD</sub> = 5V, DSA\_V<sub>DD</sub> = 3.3V unless otherwise noted and Application Circuit refer to Table 15.

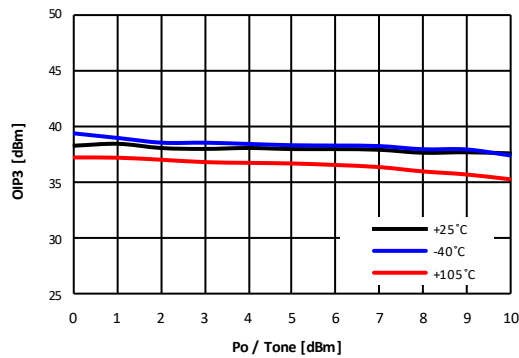
**Figure 75. Output Return Loss vs Frequency**  
over Major Attenuation Setting(DSA1 Att Control, DSA2 Att Setting 0dB)



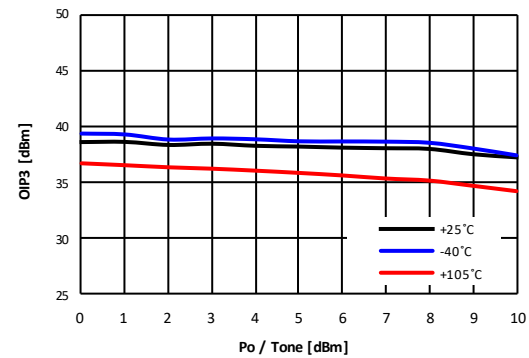
**Figure 76. Output Return Loss vs Frequency**  
over Major Attenuation Setting(DSA2 Att Control, DSA1 Att Setting 0dB)



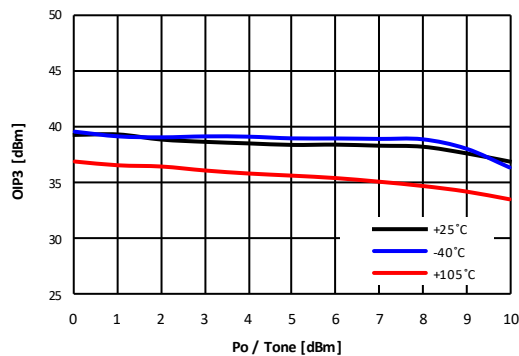
**Figure 77. OIP3 vs Output Power**  
over Temperature(@2.3GHz, DSA1,2 Att Setting 0dB)



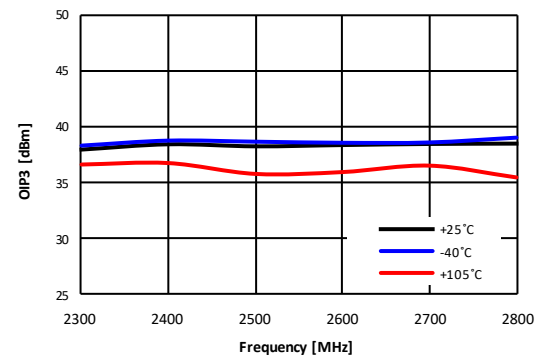
**Figure 78. OIP3 vs Output Power**  
over Temperature(@2.55GHz, DSA1,2 Att Setting 0dB)



**Figure 79. OIP3 vs Output Power**  
over Temperature(@2.8GHz, DSA1,2 Att Setting 0dB)



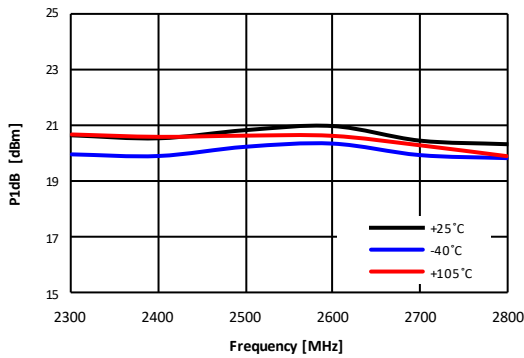
**Figure 80. OIP3 vs Frequency**  
over Temperature(DSA1,2 Att Setting 0dB)



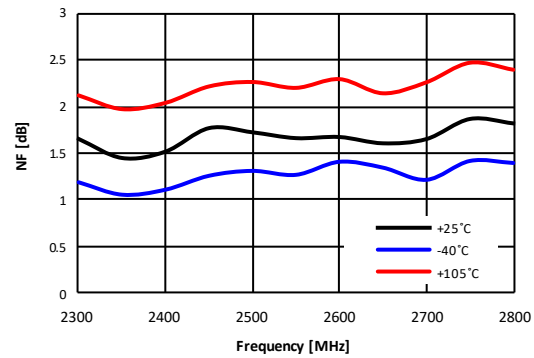
### Typical RF Performance Plot - BVA2182 EVK - PCB (Application Circuit: 2.3-2.8GHz)

Typical Performance Data @ 25°C and AMP\_V<sub>DD</sub> = 5V, DSA\_V<sub>DD</sub> = 3.3V unless otherwise noted and Application Circuit refer to Table 15.

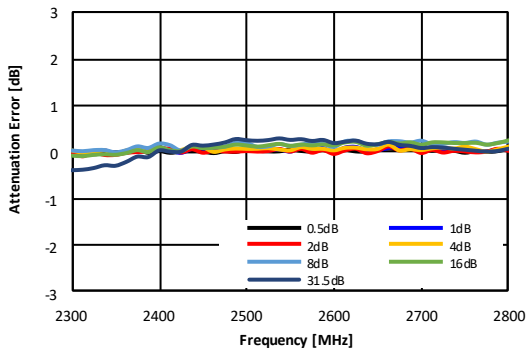
**Figure 81. OP1dB vs Frequency**  
over Temperature(DSA1,2 Att Setting 0dB)



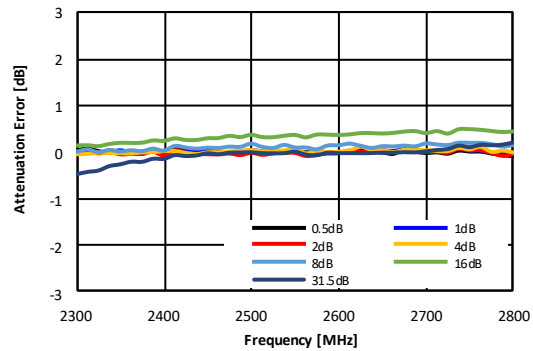
**Figure 82. NF vs Frequency**  
over Temperature(DSA1,2 Att Setting 0dB)



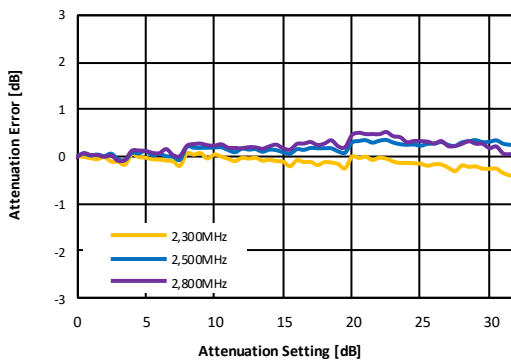
**Figure 83. Attenuation Error vs Frequency**  
over Major Attenuation Setting(DSA1 Control, DSA2 Att Setting 0dB @+25°C)



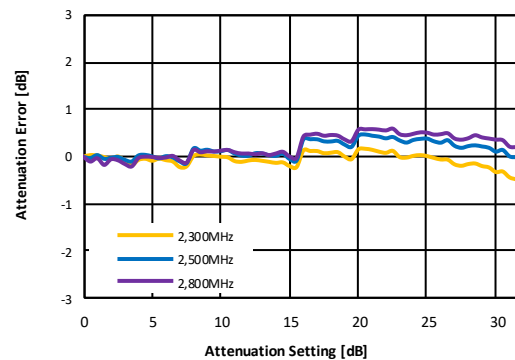
**Figure 84. Attenuation Error vs Frequency**  
over Major Attenuation Setting(DSA2 Control, DSA1 Att Setting 0dB @+25°C)



**Figure 85. Attenuation Error vs Attenuation Setting**  
over Major Frequency(DSA1 Control, DSA2 Att Setting 0dB)



**Figure 86. Attenuation Error vs Attenuation Setting**  
over Major Frequency(DSA2 Control, DSA1 Att Setting 0dB)

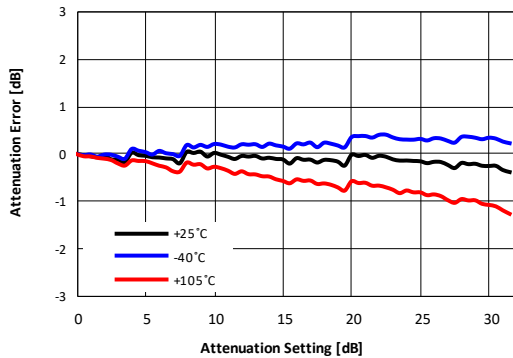




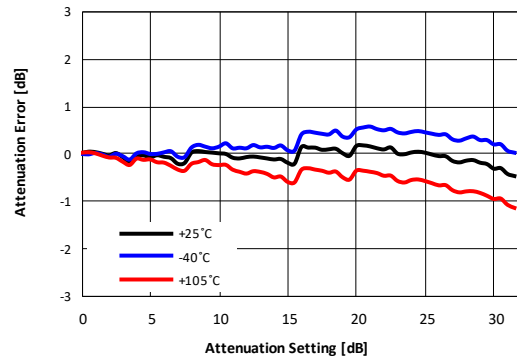
### Typical RF Performance Plot - BVA2182 EVK - PCB (Application Circuit: 2.3-2.8GHz)

Typical Performance Data @ 25°C and AMP\_VDD = 5V, DSA\_VDD = 3.3V unless otherwise noted and Application Circuit refer to Table 15.

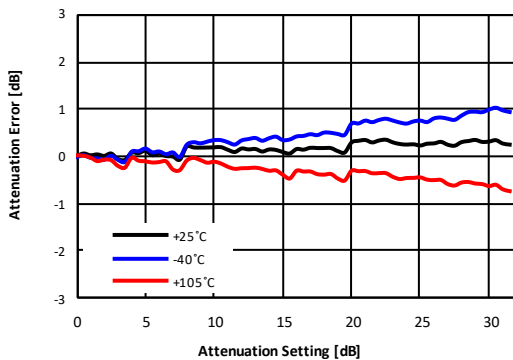
**Figure 87. Attenuation Error vs Attenuation Setting**  
over Temperature(@2.3GHz, DSA1 Control, DSA2 Att Setting 0dB)



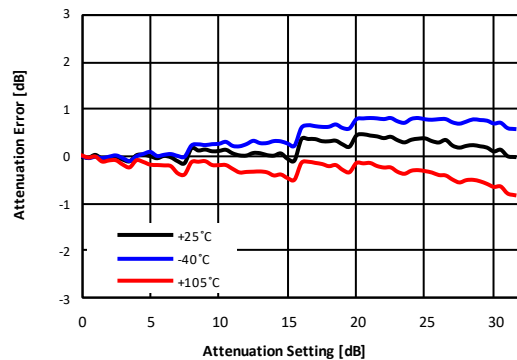
**Figure 88. Attenuation Error vs Attenuation Setting**  
over Temperature(@2.3GHz, DSA2 Control, DSA1 Att Setting 0dB)



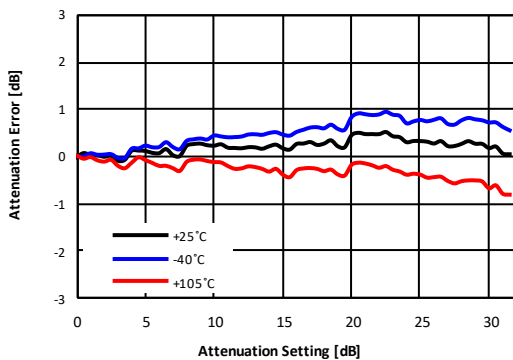
**Figure 89. Attenuation Error vs Attenuation Setting**  
over Temperature(@2.55GHz, DSA1 Control, DSA2 Att Setting 0dB)



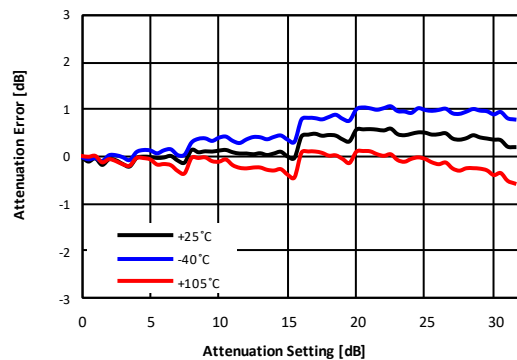
**Figure 90. Attenuation Error vs Attenuation Setting**  
over Temperature(@2.55GHz, DSA2 Control, DSA1 Att Setting 0dB)



**Figure 91. Attenuation Error vs Attenuation Setting**  
over Temperature(@2.8GHz, DSA1 Control, DSA2 Att Setting 0dB)



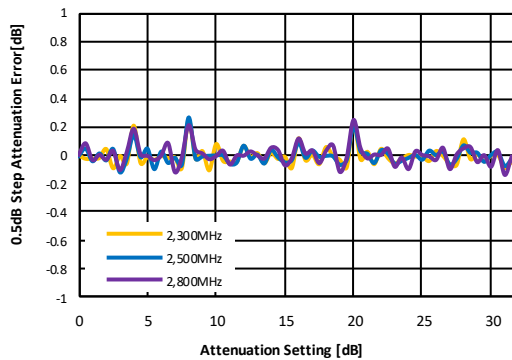
**Figure 92. Attenuation Error vs Attenuation Setting**  
over Temperature(@2.8GHz, DSA2 Control, DSA1 Att Setting 0dB)



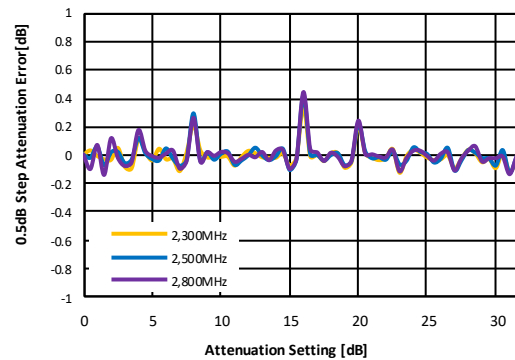
### Typical RF Performance Plot - BVA2182 EVK - PCB (Application Circuit: 2.3-2.8GHz)

Typical Performance Data @ 25°C and AMP\_VDD = 5V, DSA\_VDD = 3.3V unless otherwise noted and Application Circuit refer to Table 15.

**Figure 93. 0.5dB Step Attenuation vs Attenuation Setting**  
over Major Attenuation Setting(DSA1 Control, DSA2 Att Setting 0dB @+25°C)



**Figure 94. 0.5dB Step Attenuation vs Attenuation Setting**  
over Major Attenuation Setting(DSA2 Control, DSA1 Att Setting 0dB @+25°C)



## DUAL DIGITAL VARIABLE GAIN AMPLIFIER

### 0.5GHz — 3.8GHz

#### Typical RF Performance Plot - BVA2182 EVK - PCB (Application Circuit: 3.3-3.8GHz)

Typical Performance Data @ 25°C and AMP\_V<sub>DD</sub> = 5V, DSA\_V<sub>DD</sub> = 3.3V unless otherwise noted and Application Circuit refer to Table 17.

Table 17. Application Circuit : 3.3 - 3.8GHz

Schematic Diagram		BOM		Remark
Ref	Size	Value		
C3	402	0.5pF		
C2	402	2.7pF		
L2	402	2nH		
C25	402	22pF		
C22	402	NC		
C23	402	22pF		
C24	402	1uF		
C16	402	22pF		
C15	402	0 ohm		
C17	402	NC		
C18	402	22pF		
C14	402	22pF		
C11	402	0.5pF		
C9	402	10pF		
C10	402	NC		
L1	402	2nH		
C37	402	10pF		
C7	402	22pF		
C8	402	1uF		
C20	402	68pF		LC Filter
L4	402	100nH		LC Filter
C19	402	22pF		
C12	402	22pF		LC Filter
L3	402	100nH		LC Filter
C13	402	68pF		
R15	402	0 ohm		
C44	402	NC		
R8	402	0 ohm		
R9	402	10k ohm		
R10	402	10k ohm		
R11	402	0 ohm		
R14	402	0 ohm		
R13	402	10k ohm		
R12	402	10k ohm		
C41	402	22pF		
C42	402	22pF		
C45	402	1uF		
C5	402	0.5pF		
C40	402	0.5pF		

NOTE: C1,C38 is 0ohm or Copper  
Any other Ref.Des(Power Supply Block), refer to table 19.

### Typical RF Performance Plot - BVA2182 EVK - PCB (Application Circuit: 3.3-3.8GHz)

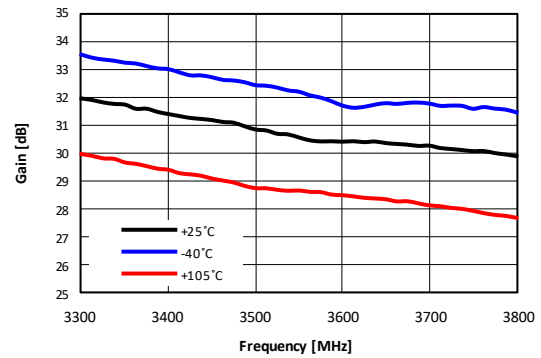
Typical Performance Data @ 25°C and AMP\_V<sub>DD</sub> = 5V, DSA\_V<sub>DD</sub> = 3.3V unless otherwise noted and Application Circuit refer to Table 17.

**Table 18. Typical RF Performance**

parameter	Typical Performance			Units
	3.3	3.5	3.8	
Frequency				GHz
Gain	32	30.8	30.2	dB
S11	-15.3	-21.3	-29.3	dB
S22	-10.0	-7.7	-6.5	dB
OIP3 <sup>1</sup>	37.5	38.7	39.2	dBm
P1dB	19.2	18.9	18.4	dBm
Noise Figure	2.0	2.2	2.4	dB

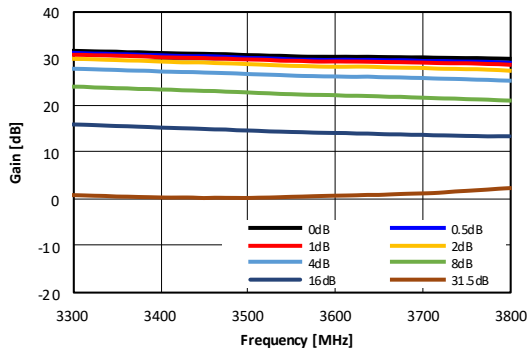
1. OIP3 measured with two tones at an output of 5 dBm per tone separated by 1 MHz.

**Figure 95. Gain vs. Frequency**  
over Temperature(DSA1,2 Att setting 0dB)



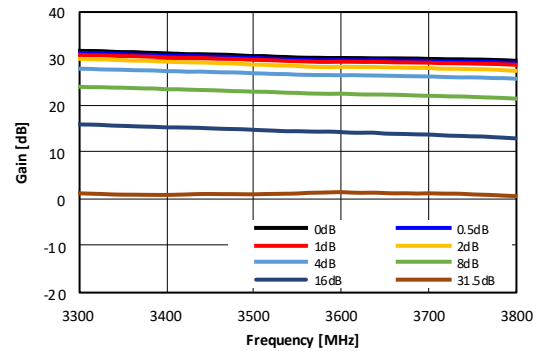
**Figure 96. Gain vs Attenuation Settings**

over Major Attenuation Setting(DSA1 Att Control, DSA2 Att setting 0dB)



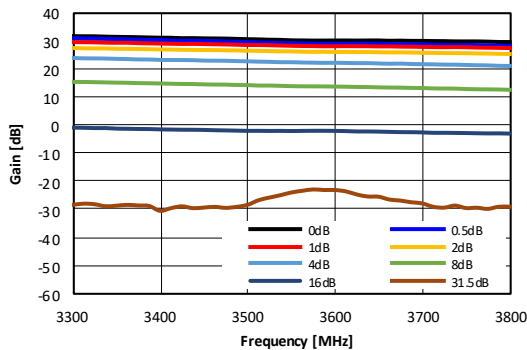
**Figure 97. Gain vs Attenuation Settings**

over Major Attenuation Setting(DSA2 Att Setting 0dB, DSA1 Att Control)



**Figure 98. Gain vs Attenuation Settings**

over Major Attenuation Setting(DSA1, DSA2 DUO Att Control, Attsettingx2 dB)



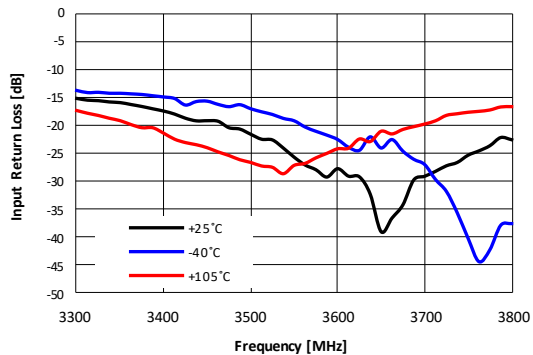
## DUAL DIGITAL VARIABLE GAIN AMPLIFIER

0.5GHz — 3.8GHz

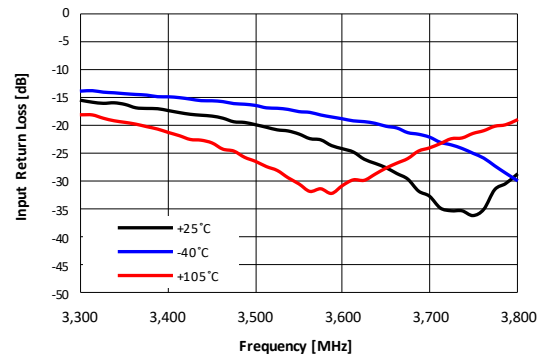
### Typical RF Performance Plot - BVA2182 EVK - PCB (Application Circuit: 3.3-3.8GHz)

Typical Performance Data @ 25°C and AMP\_V<sub>DD</sub> = 5V, DSA\_V<sub>DD</sub> = 3.3V unless otherwise noted and Application Circuit refer to Table 17.

**Figure 99. Input Return Loss vs Frequency**  
over Temperature(DSA1,2 Att Setting 0dB)

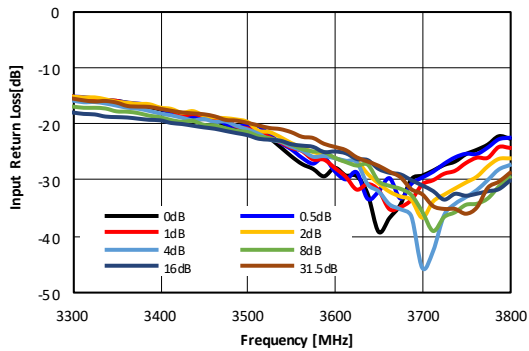


**Figure 100. Input Return Loss vs Frequency**  
over Temperature(DSA1, DSA2 DUO Att Control, Attsetting 31.5dB)

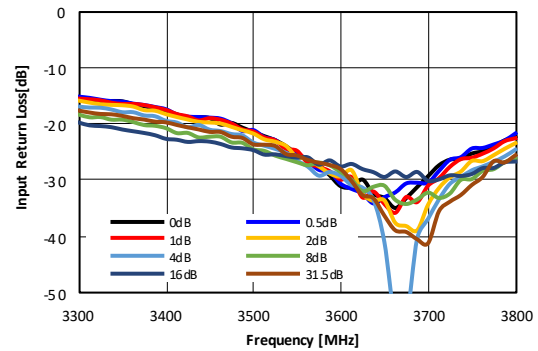


\*Att setting x2 means a total of 4dB DSA1 2dB and DSA2 2dB, when att setting is 2dB.

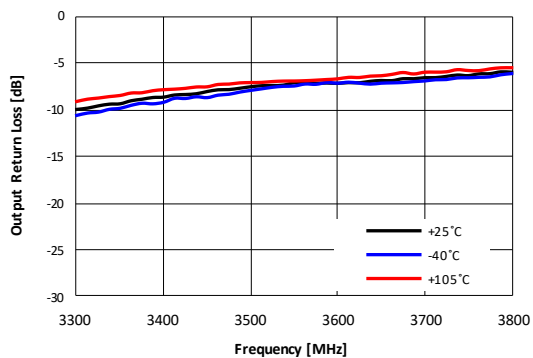
**Figure 101. Input Return Loss vs Frequency**  
over Major Attenuation Setting(DSA1 Att Control, DSA2 Att Setting 0dB)



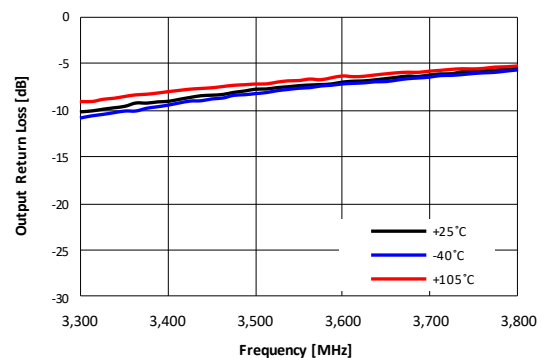
**Figure 102. Input Return Loss vs Frequency**  
over Major Attenuation Setting(DSA2 Att Control, DSA1 Att Setting 0dB)



**Figure 103. Output Return Loss vs Frequency**  
over Temperature(DSA1,2 Att Setting 0dB)



**Figure 104. Output Return Loss vs Frequency**  
over Temperature(DSA1, DSA2 DUO Att Control, Attsetting 31.5dB)



## DUAL DIGITAL VARIABLE GAIN AMPLIFIER

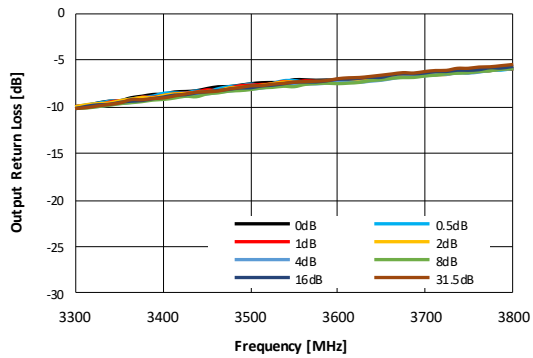
0.5GHz — 3.8GHz

### Typical RF Performance Plot - BVA2182 EVK - PCB (Application Circuit: 3.3-3.8GHz)

Typical Performance Data @ 25°C and AMP\_V<sub>DD</sub> = 5V, DSA\_V<sub>DD</sub> = 3.3V unless otherwise noted and Application Circuit refer to Table 17.

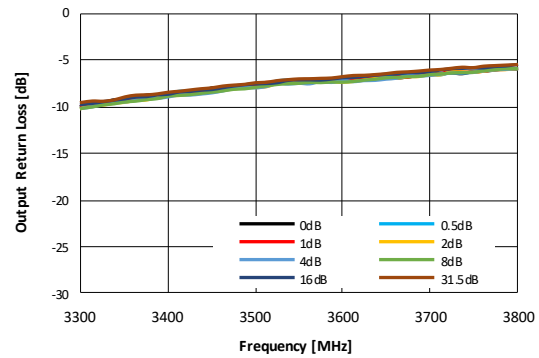
**Figure 105. Output Return Loss vs Frequency**

over Major Attenuation Setting(DSA1 Att Control, DSA2 Att Setting 0dB)



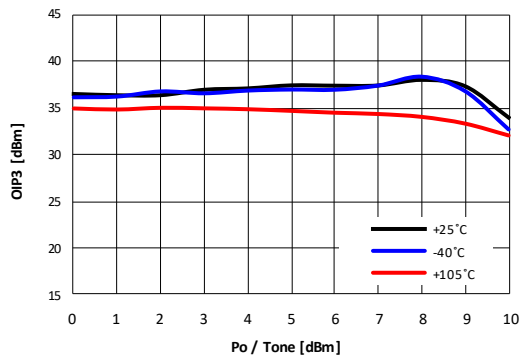
**Figure 106. Output Return Loss vs Frequency**

over Major Attenuation Setting(DSA2 Att Control, DSA1 Att Setting 0dB)



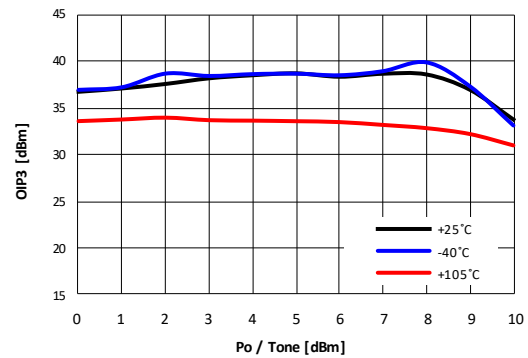
**Figure 107. OIP3 vs Output Power**

over Temperature(@3.3GHz, DSA1,2 Att Setting 0dB)



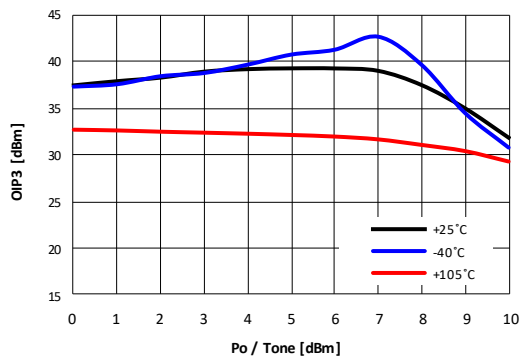
**Figure 108. OIP3 vs Output Power**

over Temperature(@3.5GHz, DSA1,2 Att Setting 0dB)



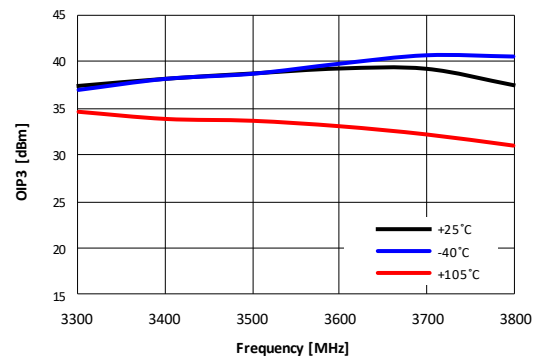
**Figure 109. OIP3 vs Output Power**

over Temperature(@3.8GHz, DSA1,2 Att Setting 0dB)



**Figure 110. OIP3 vs Frequency**

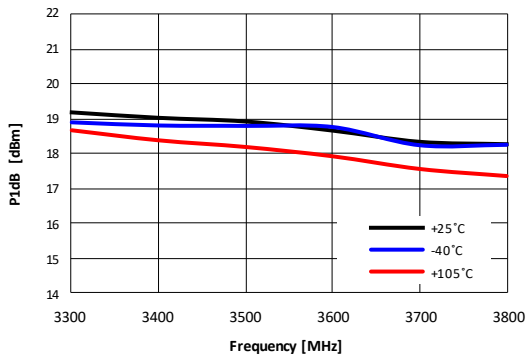
over Temperature(DSA1,2 Att Setting 0dB)



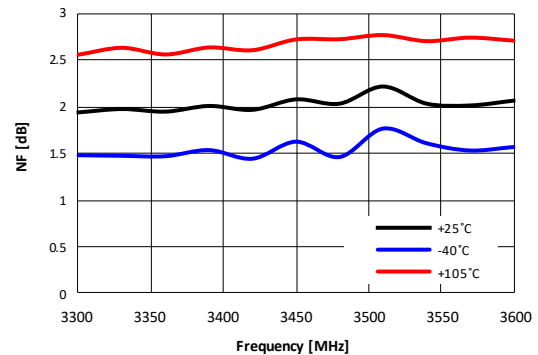
### Typical RF Performance Plot - BVA2182 EVK - PCB (Application Circuit: 3.3-3.8GHz)

Typical Performance Data @ 25°C and AMP\_V<sub>DD</sub> = 5V, DSA\_V<sub>DD</sub> = 3.3V unless otherwise noted and Application Circuit refer to Table 17.

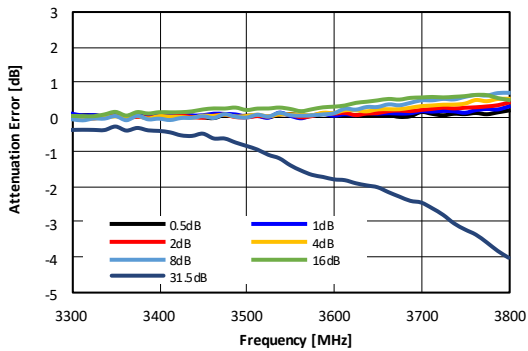
**Figure 111. OP1dB vs Frequency**  
over Temperature(DSA1,2 Att Setting 0dB)



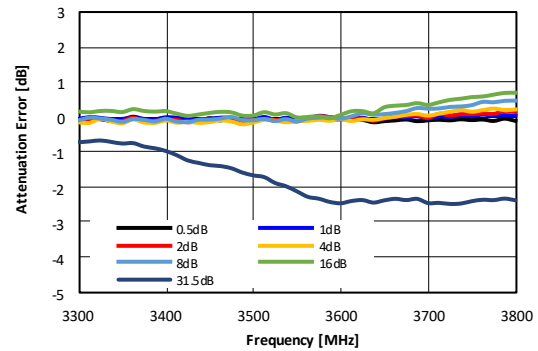
**Figure 112. NF vs Frequency**  
over Temperature(DSA1,2 Att Setting 0dB)



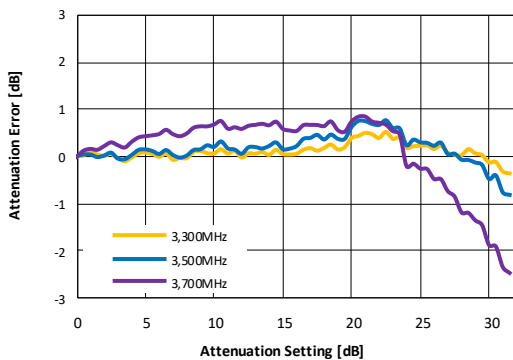
**Figure 113. Attenuation Error vs Frequency**  
over Major Attenuation Setting(DSA1 Control, DSA2 Att Setting 0dB @+25°C)



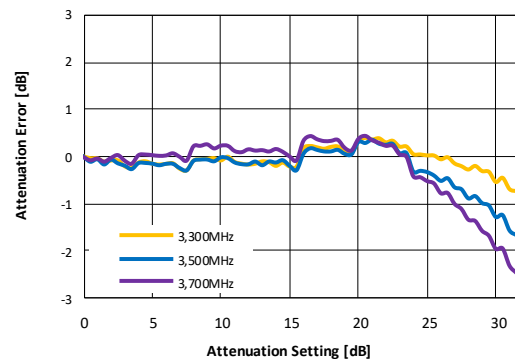
**Figure 114. Attenuation Error vs Frequency**  
over Major Attenuation Setting(DSA2 Control, DSA1 Att Setting 0dB @+25°C)



**Figure 115. Attenuation Error vs Attenuation Setting**  
over Major Frequency(DSA1 Control, DSA2 Att Setting 0dB)



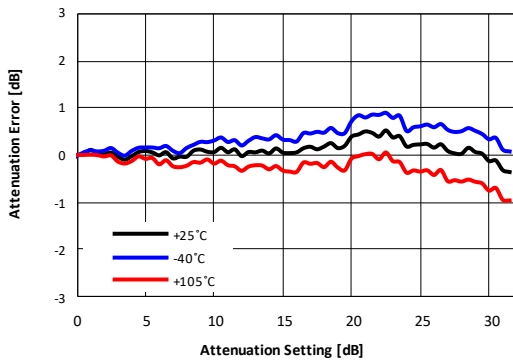
**Figure 116. Attenuation Error vs Attenuation Setting**  
over Major Frequency(DSA2 Control, DSA1 Att Setting 0dB)



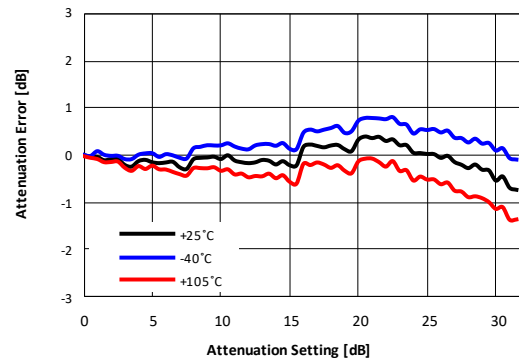
### Typical RF Performance Plot - BVA2182 EVK - PCB (Application Circuit: 3.3-3.8GHz)

Typical Performance Data @ 25°C and AMP\_VDD = 5V, DSA\_VDD = 3.3V unless otherwise noted and Application Circuit refer to Table 17.

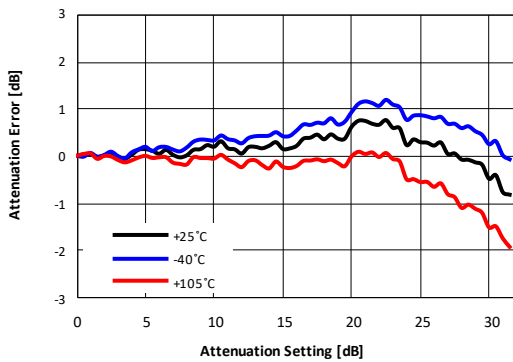
**Figure 117. Attenuation Error vs Attenuation Setting**  
over Temperature(@3.3GHz, DSA1 Control, DSA2 Att Setting 0dB)



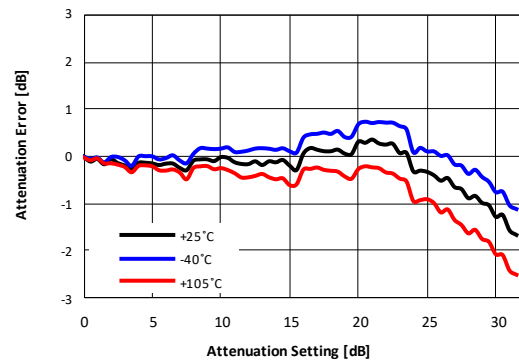
**Figure 118. Attenuation Error vs Attenuation Setting**  
over Temperature(@3.3GHz, DSA2 Control, DSA1 Att Setting 0dB)



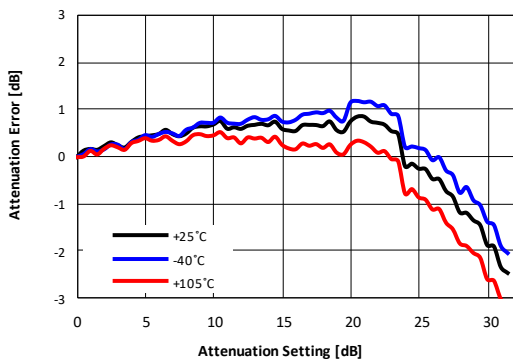
**Figure 119. Attenuation Error vs Attenuation Setting**  
over Temperature(@3.5GHz, DSA1 Control, DSA2 Att Setting 0dB)



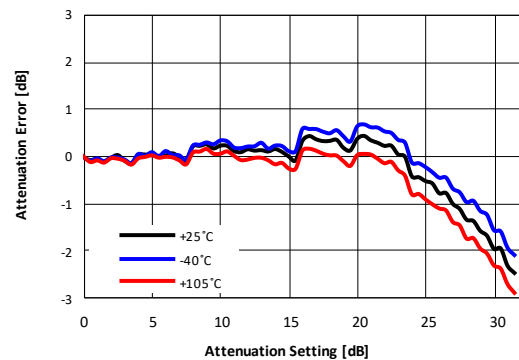
**Figure 120. Attenuation Error vs Attenuation Setting**  
over Temperature(@3.5GHz, DSA2 Control, DSA1 Att Setting 0dB)



**Figure 121. Attenuation Error vs Attenuation Setting**  
over Temperature(@3.8GHz, DSA1 Control, DSA2 Att Setting 0dB)



**Figure 122. Attenuation Error vs Attenuation Setting**  
over Temperature(@3.8GHz, DSA2 Control, DSA1 Att Setting 0dB)

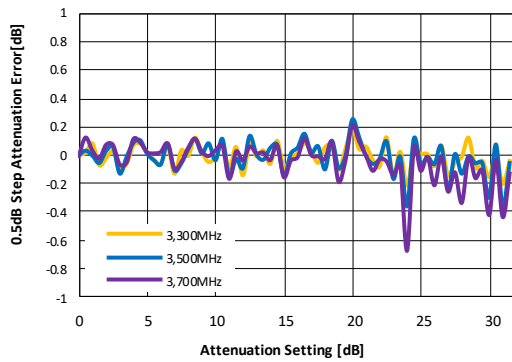




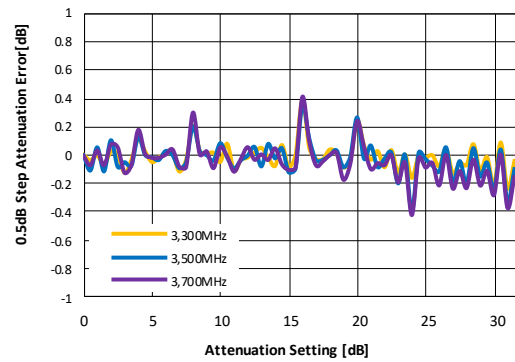
### Typical RF Performance Plot - BVA2182 EVK - PCB (Application Circuit: 3.3-3.8GHz)

Typical Performance Data @ 25°C and AMP\_VDD = 5V, DSA\_VDD = 3.3V unless otherwise noted and Application Circuit refer to Table 17.

**Figure 123. 0.5dB Step Attenuation vs Attenuation Setting**  
over Major Attenuation Setting(DSA1 Control, DSA2 Att Setting 0dB @+25°C)



**Figure 124. 0.5dB Step Attenuation vs Attenuation Setting**  
over Major Attenuation Setting(DSA2 Control, DSA1 Att Setting 0dB @+25°C)



## DUAL DIGITAL VARIABLE GAIN AMPLIFIER

0.5GHz — 3.8GHz

Figure 125. Evaluation Board Schematic

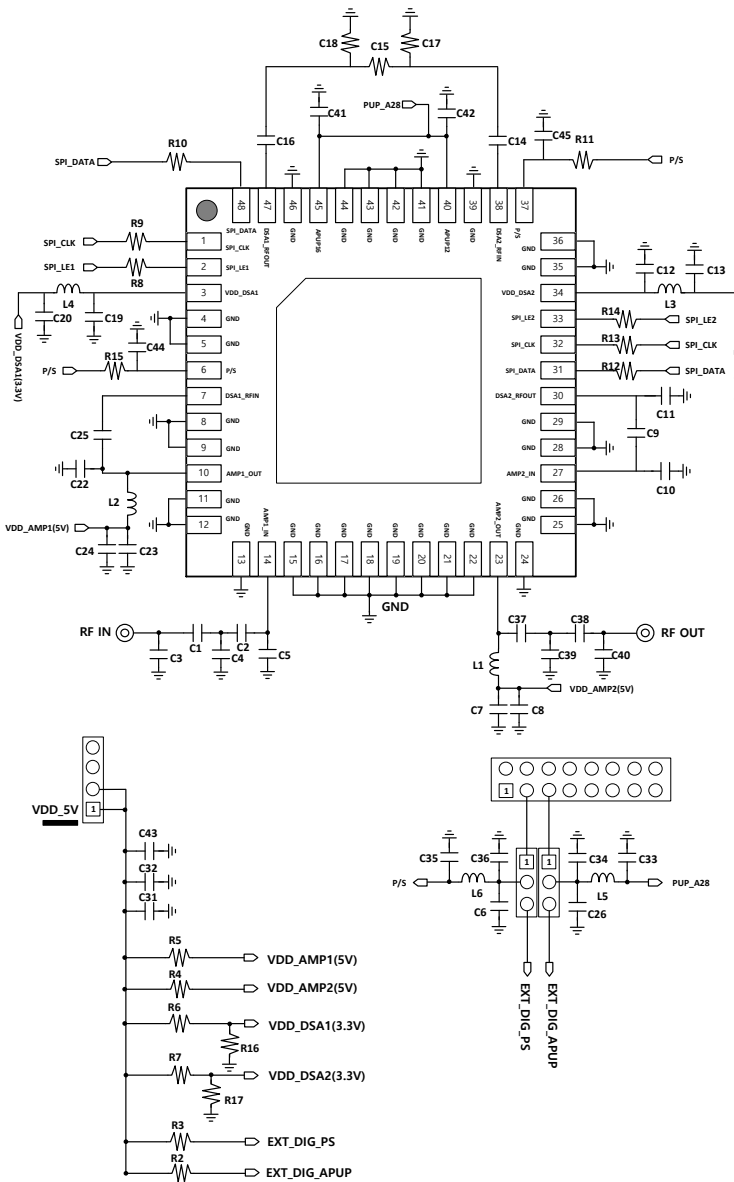


Table 19. Power Supply Block BOM

No	BOM			Remark
	Ref	Size	Value	
1	C43	0402	10uF	Tantal
2	C32	0402	4.7uF	
3	C31	0402	NC	
4	R5	0402	0ohm	
5	R4	0402	0ohm	
6	R6	0402	5.6k ohm	
7	R16	0402	91 k ohm	
8	R7	0402	5.6k ohm	
9	R17	0402	91 k ohm	
10	R3	0402	NC	
11	R2	0402	NC	
12	C36	0402	68pF	
13	L6	0402	100nH	
14	C35	0402	22pF	
15	C6	0402	NC	
16	C33	0402	22pF	
17	L5	0402	100nH	
18	C34	0402	68pF	
19	C26	0402	NC	
20	C27	0402	100pF	
21	C28	0402	100pF	
22	C29	0402	100pF	
23	C30	0402	100pF	

Figure 126. Evaluation Board PCB Layer Information

EM825B Er: 4.6~4.8	COPPER :1oz + 0.5oz (plating), Top Layer	↑
	P.P : (0.2+0.06+0.06) TOTAL = 0.32mm	
MTC Er:4.6	COPPER :1oz (GND), Inner Layer	↓
	CORE : 0.73mm	
EM825B Er:4.6~4.8	COPPER :1oz, Inner Layer	FINISH TICKNESS :1.55T
	P.P : (0.2+0.06+0.06) TOTAL = 0.32mm	
	COPPER :1oz + 0.5oz (plating), Bottom Layer	

Figure 127. Evaluation Board Layout

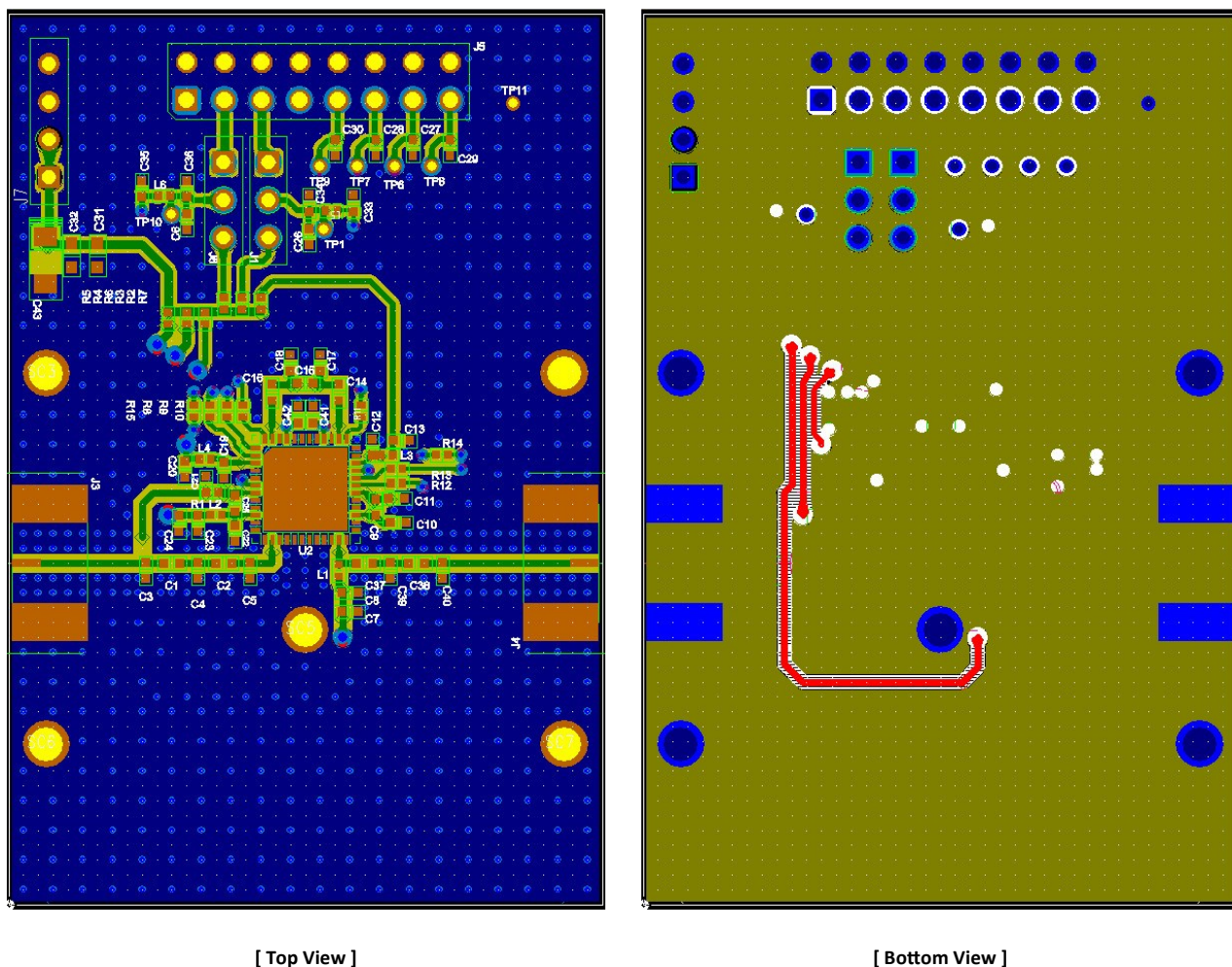


Figure 128. Packing outline Dimension

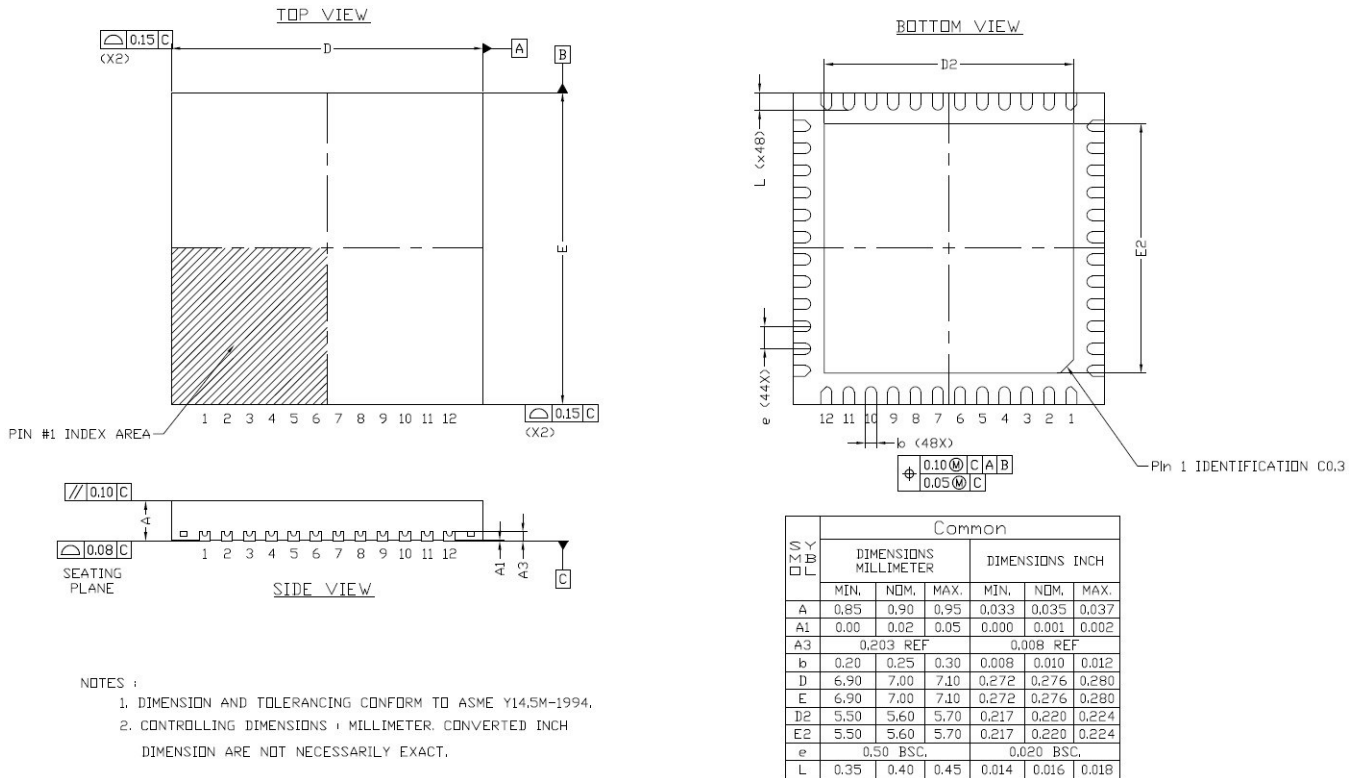


Figure 129. Suggested PCB Land Pattern and PAD Layout

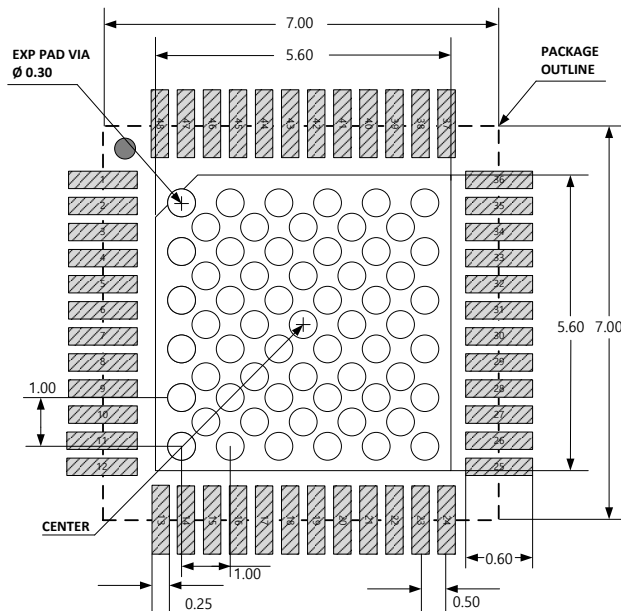



Figure 130. Tape & Reel

TBD

Packaging information:	
Tape Width	
Reel Size	
Device Cavity Pitch	
Devices Per Reel	

Figure 131. Package Marking

	Marking information:	
	BVA2182	Device Name
	YY	Year
	WW	Work Week
	XX	LOT Number

### RoHS2 Compliance

BVA2182 is compliant with 2011/65/EU RoHS2 directive. (Restrictions on the Use of Certain Hazardous Substances in Electrical and Electronic equipment.)

### Lead plating finish

#### 100% Tin Matte finish

(All BeRex products undergoes a 1 hour, 150 degree C, Anneal bake to eliminate thin whisker growth concerns.)

### MSL / ESD Rating

<b>ESD Rating:</b>	Class 1C
<b>Value:</b>	Passes $\leq$ 2000V
<b>Test:</b>	Human Body Model(HBM)
<b>Standard:</b>	JEDEC Standard JS-001-2017
<b>MSL Rating:</b>	<b>Level 1 at +265°C convection reflow</b>
<b>Standard:</b>	JEDEC Standard J-STD-020



Proper ESD procedures should be followed when handling this device.

### NATO CAGE code:

2	N	9	6	F
---	---	---	---	---