

PART NUMBER	REV	FIRST USED
680716-1	B	122500-1
680716-2	B	565435-5

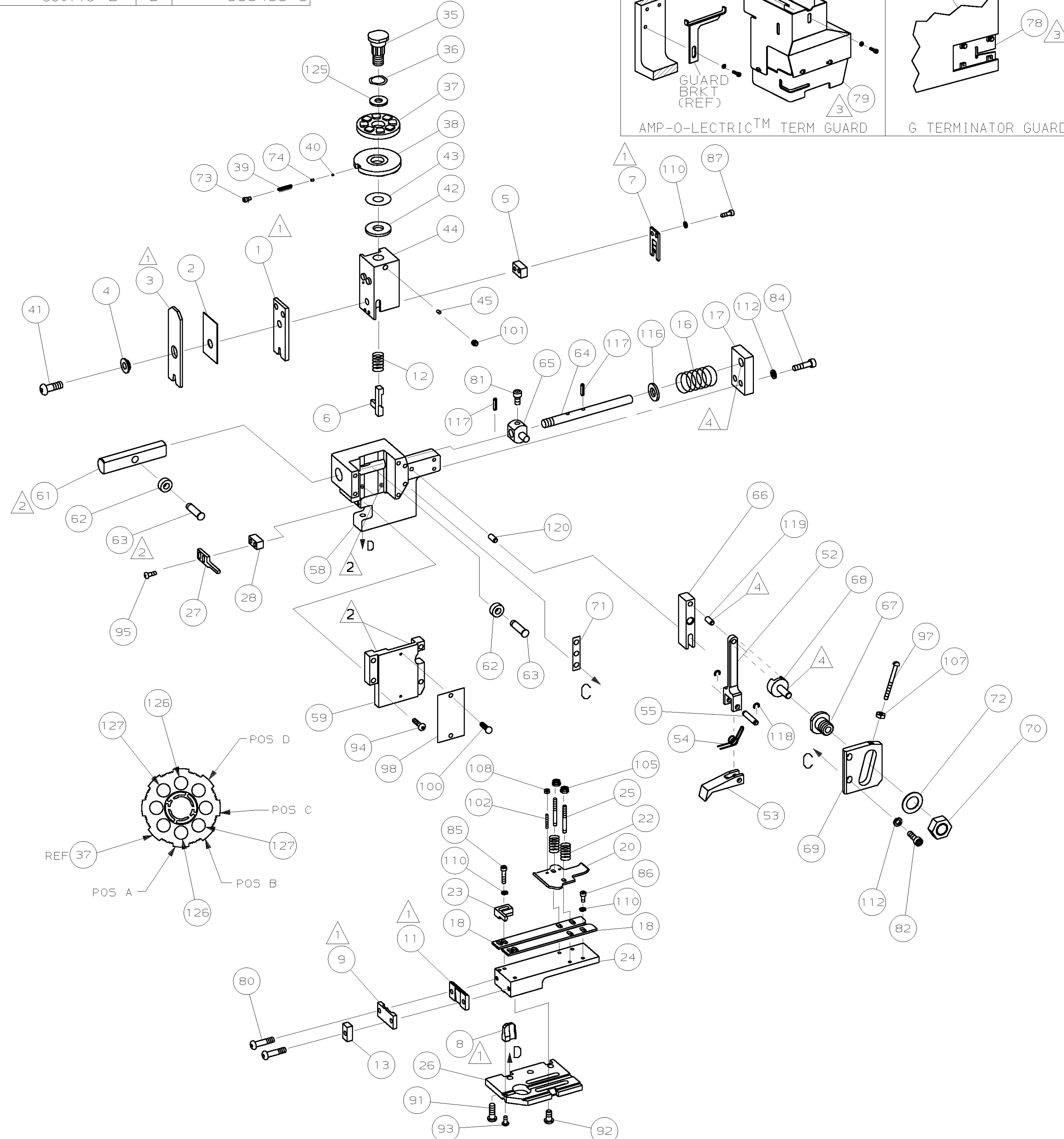
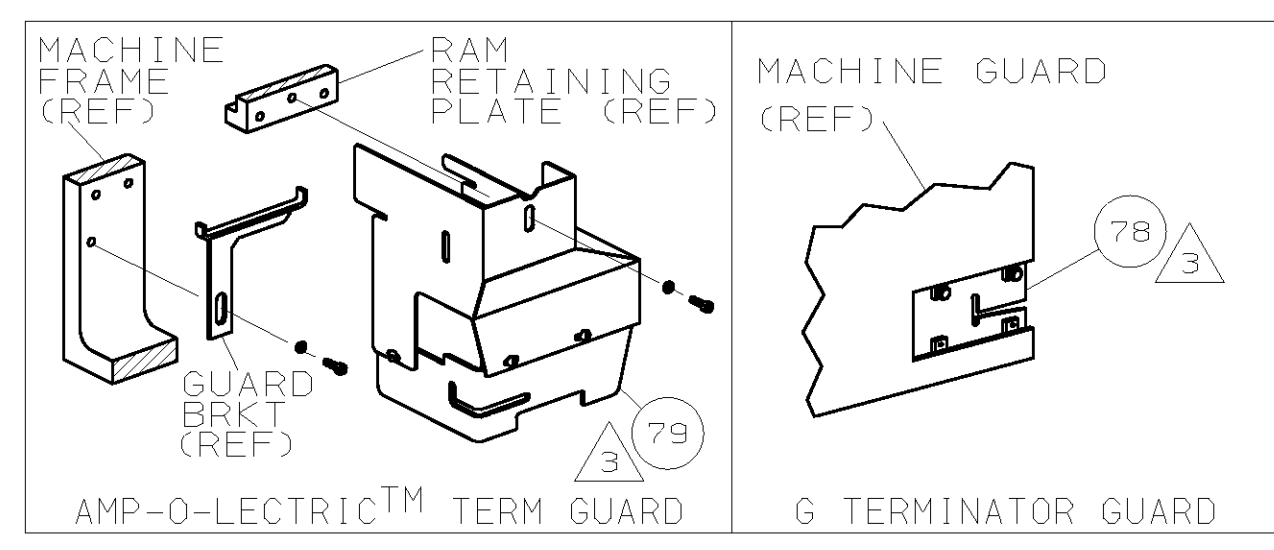

TERMINAL NAME: RECEPTACLE			
286754			
PAD LTR	CRIMP HEIGHT	WIRE SIZE	
A	.062 ±.002 [1.57 ±0.05mm]	(2) 0.5mm ²	
B	NOT	USED	
C	NOT	USED	
D	NOT	USED	
CRIMP	SIZE	TYPE	RANGE
WIRE	.120 [3.05mm]	F	0.5mm ²
INSUL	.180 [4.57mm]	0	(2) ∅.065
WIRE STRIP LENGTH	TERM APPL SPEC	FEED	APPL INSTRUCTION
.156-.181	NONE	.742	408-8039
			SET UP GAGE LAYOUT
			458638-1 L2122

-1		LEADMAKER & BENCH MODEL G	MECH POST FEED	
REF	REF	- A	22594-8	NUT, HEX
REF	REF	- B	240628-1	PLATE, ADJ
REF	REF	- B	240626-1	SHAFT, PIVOT
REF	REF	- B	240633-1	BUSHING
REF	REF	- A	455680-1	LEVER, INTERMEDIATE
REF	REF	- B	240629-1	BLOCK, PIVOT
REF	REF	- A	240632-2	SCR, ADJ
REF	REF	- B	240659-3	PIN, CAM ROLLER
REF	REF	- B	240658-1	CAM, ROLLER
REF	REF	- B	454398-1	ROD, FEED

					129	
					128	
					127	
2	2	-	C	354779-2	PIN, WIRE DISC (.3000)A	126
1	1	-	A	986950-1	WASHER, FLAT PRECISION	125
1	1	-	A	217238-1	GENERAL INSTRUCTION PACKAGE	124
1	1	-	-	4088039	EF APPL INST 408-8039	123
					122	
					121	
REF	REF	-	A	1-21030-7	PIN, DOWEL (∅.187x1.50)H5G	120
REF	REF	-	A	1-21030-1	PIN, DOWEL (∅.187x.50)LEVER	119
REF	REF	-	A	21045-3	RING, RET "C" (∅.187)FD PIN	118
REF	REF	-	A	5-21028-1	PIN, STD SPRING (∅.12)FD ADJ ROD	117
REF	REF	-	A	21899-4	WASHER, FLAT (∅5/16)SCR ADJ	116
					115	
					114	
					113	
REF	REF	-	A	21024-5	WASHER, LOCK (NO.10)FD ROD GDE	112
					111	
7	7	-	A	21024-4	WASHER, LOCK (NO.8)SHEAR BL	110
					109	
2	2	-	A	21018-4	NUT, HEX (4-40)DRAG	108
REF	REF	-	A	21018-5	NUT, HEX (6-32)FD ADJ PL	107
					106	
					105	
					104	
					103	
2	2	-	A	2-21006-6	SCR, SKT SET (4-40x.62)DRAG	102
1	1	-	A	21009-2	SCR, SKT SET (1/4-20x.25)RAM	101
2	2	-	A	21017-2	SCR, DRIVE (#2x.19) ID PLATE	100
1	1	-	A	1-21002-7	SCR, BHC (6-32x.38) CAM	99
1	1	-	B	461264-1	PLATE, IDENTIFICATION	98
REF	REF	-	A	6-23715-5	SCR, PAN HD (6-32x1.50)FEED ADJ	97
					96	
2	2	-	A	2-21002-2	SCR, BHC (8-32x.50)STRIPPER	95
REF	REF	-	A	2-21002-9	SCR, BHC (10-32x.75)H5G CAP	94
1	1	-	A	22733-8	SCR, BHC (8-32x.38 LW) ANVIL	93
4	4	-	A	3-21002-3	SCR, BHC (1/4-20x.50)ST 6D PL	92
REF	REF	-	A	2-22733-8	SCR, BHC (1/4-20x.62)BASE PL	91
					90	
					89	
					88	
2	2	-	A	2-21000-7	SCR, SHC (8-32x.50)SLUG BLADE	87
3	3	-	A	2-21000-5	SCR, SHC (8-32x.250)STRIP GUIDE	86
2	2	-	A	2-21000-9	SCR, SHC (8-32x.75)R STRIP GUIDE	85
REF	REF	-	A	3-21000-7	SCR, SHC (10-32x.75)FEED ROD GDE	84
					83	
REF	REF	-	A	3-21000-6	SCR, SHC (10-32x.62)FEED ADJ PL	82
REF	REF	-	A	3-21000-4	SCR, SHC (10-32x.38)PIVOT BLOCK	81
2	2	-	A	3-21002-0	SCR, BHC (10-32x.88)SHEAR PL	80
REF	-	-	A	455745-1	GUARD, WINDOW	79
-	REF	-	A	679532-1	INSERT, GUARD	78
					77	
					76	
					75	
1	1	-	A	690603-1	SPRING, ASSIST	74
1	1	-	A	23030-1	SCR, SKT CAP (6-32x.25)CP DSC	73
REF	REF	-	A	458109-1	WASHER, FLAT (SPECIAL)	72
REF	REF	-	A	690517-1	SPACER	71

					60	
					59	
					58	
					57	
					56	
					55	
REF	REF	-	B	240624-1	PIN, FEED FINGER	54
REF	REF	-	B	691499-1	SPRING, FEED FINGER	53
REF	REF	-	B	240635-1	FINGER, FEED	52
REF	REF	-	B	240634-1	LEVER, TERMINAL	51
					50	
					49	
1	-	-	B	690501-3	CAM, POST FEED 1 1/8 ST	48
-	1	-	B	690501-4	CAM, POST-FEED 1 5/8 ST	47
					46	
1	1	-	A	690191-1	PLUG, NYLON	45
1	1	-	C	455674-1	RAM	44
1	1	-	A	690125-1	WASHER, LAMINATED	43
1	1	-	A	690124-1	WASHER, RAM	42
1	1	-	A	7-21002-9	BOLT, CRIMPER (5/16-24x1.00)	41
1	1	-	A	23241-6	BALL, STEEL	40
1	1	-	A	690170-1	SPRING, COMPRESSION	39
1	1	-	C	690142-1	DISC, INSULATION	38
1	1	-	D	354777-1	WIRE DISC, PLASTIC	37
1	1	-	A	22480-5	WASHER, SPRING	36
1	1	-	B	690212-1	POST, RAM	35
					34	
					33	
					32	
1	1	-	D	458980-1	APPLICATOR, BASIC (SUB ASSY)	31
					30	
					29	
1	1	-	B	3-690451-2	SPACER, STRIPPER	28
1	1	-	A	240639-1	STRIPPER	27
REF	REF	-	C	455676-1	PLATE, BASE	26
2	2	-	A	22354-8	DRAG, STUD	25
1	1	-	B	458803-3	PLATE, STRIP GUIDE	24
1	1	-	C	240825-9	PLATE, STRIP HOLD DOWN	23
2	2	-	A	4-22281-1	SPRING, DRAG	22
					21	
1	1	-	A	454177-1	DRAG, STOCK	20
					19	
					18	
2	2	-	C	454204-4	GUIDE, STRIP (FRONT)	18
REF	REF	-	A	454178-1	GUIDE, FEED ROD	17
REF	REF	-	A	4-22284-9	SPRING, FEED RETURN	16
					15	
					14	
1	1	-	B	690481-2	SPACER, HOLDDOWN	13
1	1	-	A	23846-1	SPRING, HOLD DOWN	12
1	1	-	B	240833-2	PLATE, REAR SHEAR	11
					10	
1	1	-	B	1-690496-9	PLATE, FRONT SHEAR	9
1	1	-	D	3-240655-5	ANVIL	8
1	1	-	B	1-690474-8	BLADE, SLUG	7
1	1	-	D	1-455892-4	HOLD DOWN, TERMINAL	6
1	1	-	C	5-240641-0	SPACER, SLUG BLADE	5
1	1	-	B	238009-1	SPACER, BLOCK CRIMPER	4
1	1	-	C	8-683454-8	CRIMPER, INSULATION	3
1	1	-	B	455888-3	SPACER, CRIMPER	2
1	1	-	C	456409-5	CRIMPER, WIRE	1

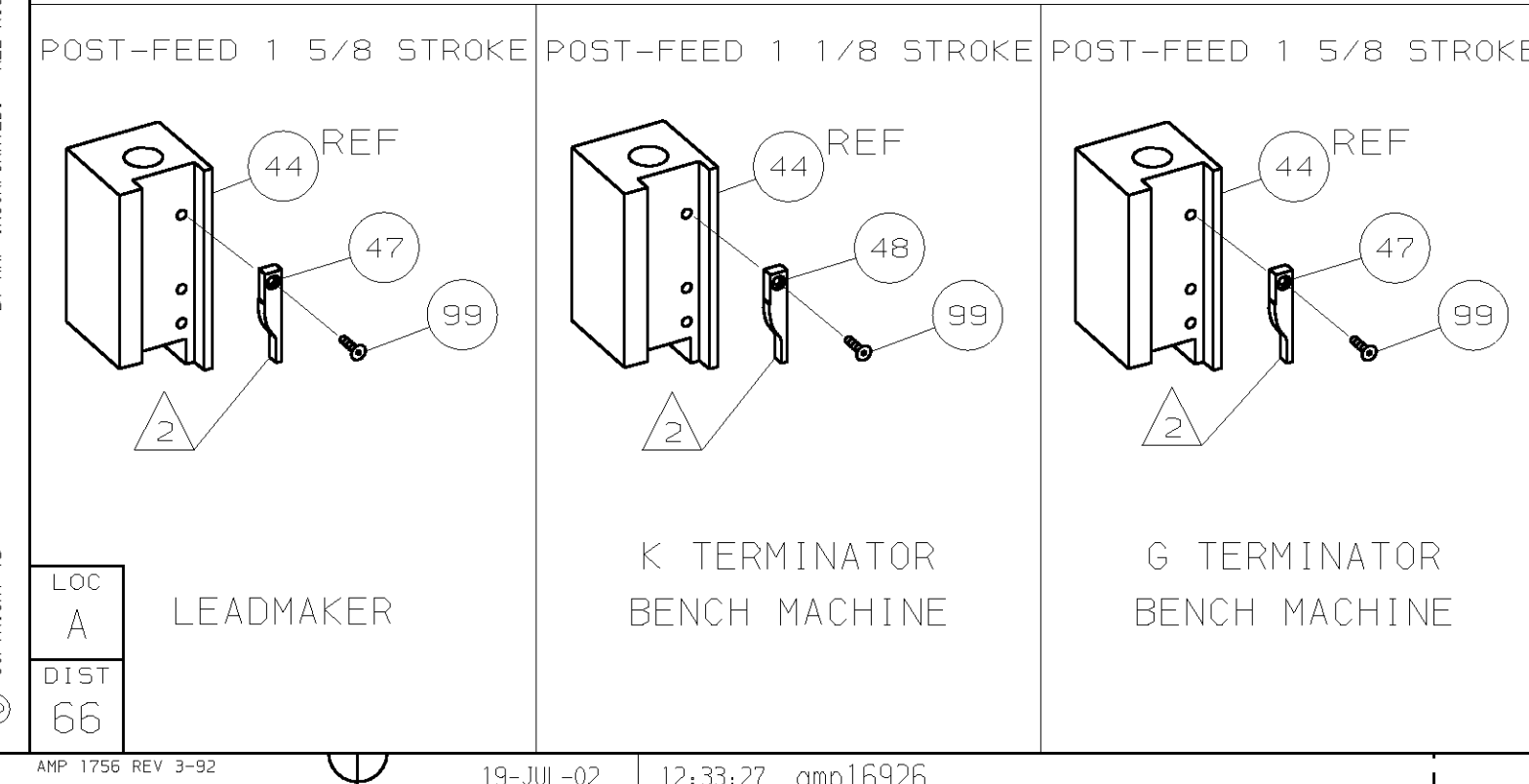

- 1 RECOMMENDED SPARE PARTS.
- 2 GREASE LIGHTLY.
- 3 GUARD MUST BE IN PLACE WHEN OPERATING APPLICATOR IN A BENCH MACHINE.
- 4 LUBRICATE DAILY USING NO. 20 MACHINE OIL.
- 5. ITEMS WITH QTY OF REF SPECIFIED (EXCEPT ITEMS 78 AND 79) ARE USED ON ITEM 32.
- 6 ITEM 78 USED WITH G TERMINATOR ONLY.

QTY REOD PER ASSY	U/M	DWG SIZE	PART NO	DESCRIPTION	ITEM NO

QTY REOD PER ASSY	U/M	DWG SIZE	PART NO	DESCRIPTION	ITEM NO