

**CI-22764-000**  
SHT 1.1

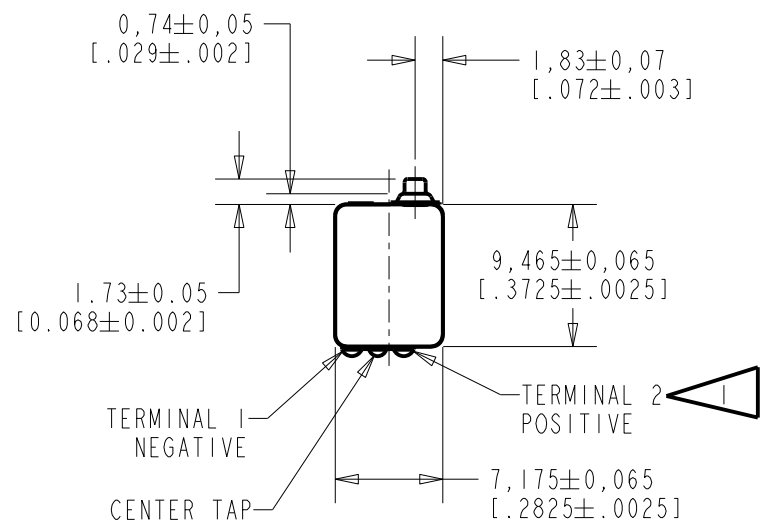

NOTES:

▲ A POSITIVE GOING VOLTAGE AT TERMINAL 2, RELATIVE TO TERMINAL 1, CAUSES AN INCREASE IN PRESSURE AT THE SOUND OUTLET.

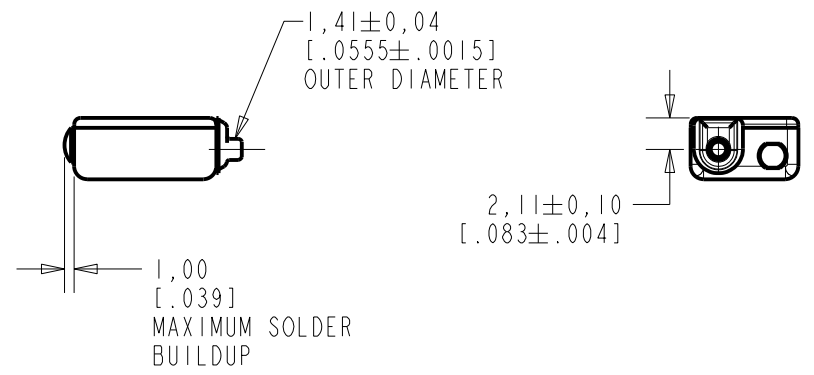
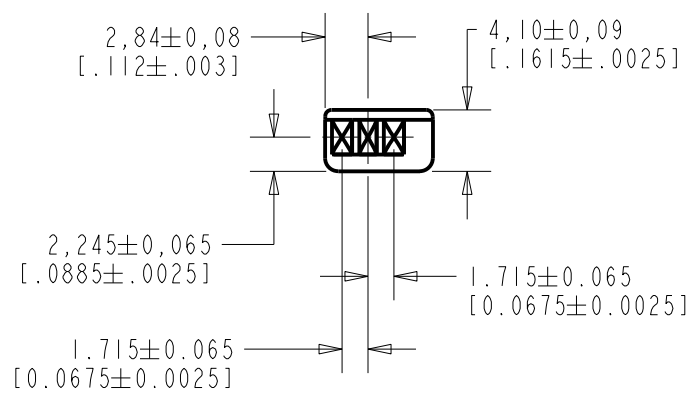

DIMENSIONS IN MILLIMETERS [INCHES]

Revision	C.O. #	Implementation Date	RELEASE LEVEL	REVISION
			<b>Active</b>	<b>D</b>
D	CI0111948	12-27-10		

**KNOWLES ELECTRONICS**  
ITASCA, ILLINOIS U.S.A.

SCALE: <b>2:1</b>	DR. BY DMS	DATE 11-30-05
DO NOT SCALE DRAWING	CK. BY GJP	DATE 12-5-05
TITLE: <b>RECEIVER</b> OUTLINE DRAWING	<b>CI-22764-000</b> SHT 1.1	APP. BY GJP
		DATE 12-5-05

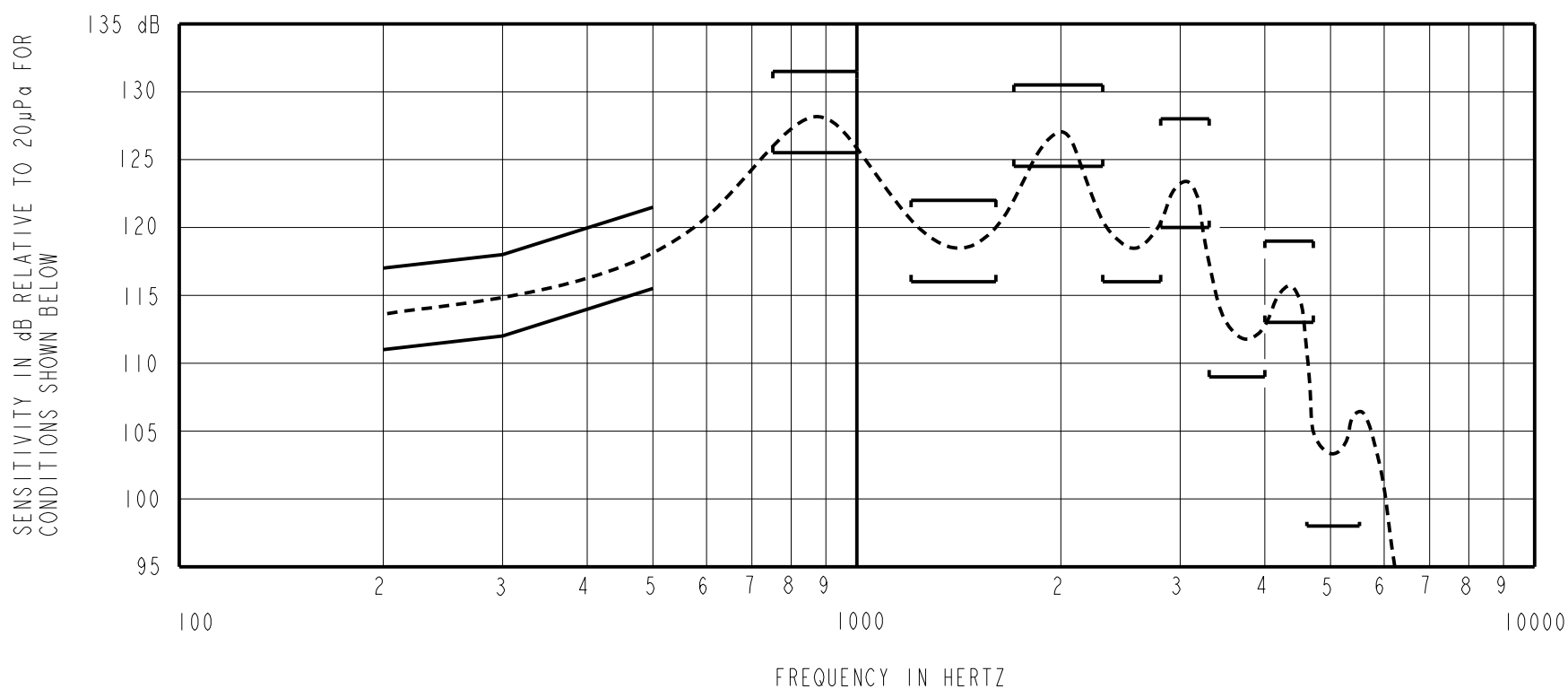

NOTES:

1. MEASUREMENTS MADE USING 38.1mm (1.5") X 1.35mm (.053") ID TUBE CONNECTED TO A SIMULATED ANSI S3.6 TYPE HA-3 (IEC 60318-5).

2. SENSITIVITY

FREQUENCY	MIN.	MAX.
200	111.0	117.0
300	112.0	118.0
500	115.5	121.5
750-1000	125.5	131.5
1200-1600	116.0	122.0
1700-2300	124.5	130.5
2300-2800	116.0	---
2800-3300	120.0	128.0
3300-4000	109.0	---
4000-4700	113.0	119.0
4600-5500	98.0	---

3. RESPONSE, IMPEDANCE, AND DISTORTION MEASUREMENTS MADE USING THE ELECTRICAL TEST CONDITIONS SHOWN BELOW.

4. INDIVIDUAL SPECIFICATIONS.

PORT LOCATION	ELECTRICAL TEST CONDITIONS				IMPEDANCE @ 500Hz OHMS ±15%	DCR @20°C OHMS ±10%	DISTORTION	
	RESPONSE & IMPEDANCE		DISTORTION				MAX. %	FREQ. Hz
	AC mA RMS	DC mA	AC mA RMS	DC mA				
IS	2.0	0.0	4.0	0.0	174	75	10	500

5. ELECTRICAL SOURCE IMPEDANCE MUST BE GREATER THAN 20 TIMES STATED IMPEDANCE FOR TEST CONDITIONS ABOVE.

Revision	C.O. #	Implementation Date	RELEASE LEVEL	REVISION
			<b>Active</b>	<b>D</b>
D	CI0111948	12-27-10		
WHEN TEST LIMITS ARE USED TO ESTABLISH INCOMING INSPECTION ACCEPTANCE/REJECTION CRITERIA, CORRELATION OF TEST EQUIPMENT WITH KNOWLES IS ALSO REQUIRED FOR ELIMINATION OF EQUIPMENT AND TEST METHOD VARIATION				
TITLE: <b>RECEIVER</b>		<b>CI-22764-000</b>		DR. BY DATE
PERFORMANCE SPECIFICATION		<b>SHT 2.1</b>		DMS 11-30-05
				CK. BY DATE
				GJP 12-5-05
				APP. BY DATE
				GJP 12-5-05

**KNOWLES ELECTRONICS**  
ITASCA, ILLINOIS U.S.A.