

1. SCOPE

1.1 Scope. This drawing describes device requirements for class B microcircuits in accordance with 1.2.1 of MIL-STD-883, "Provisions for the use of MIL-STD-883 in conjunction with compliant non-JAN devices".

1.2 Part number. The complete part number shall be as shown in the following example:

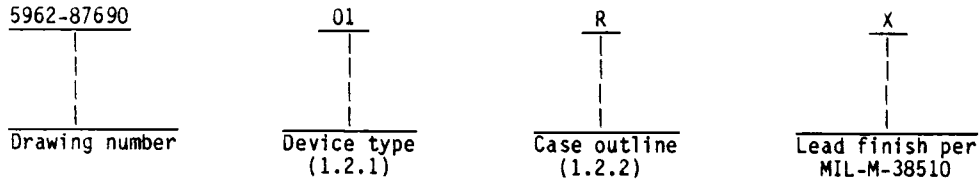

1.2.1 Device types. The device types shall identify the circuit function as follows:

Device type	Generic number	Circuit function	Access time
01	27S29	512 x 8 Bit Bipolar PROM, T.S.	70 ns
02	27S29A	512 x 8 Bit Bipolar PROM, T.S.	45 ns

1.2.2 Case outlines. The case outlines shall be as designated in appendix C of MIL-M-38510, and as follows:

Outline letter	Case outline
R	D-8 (20-Lead, 1/4" x 1-1/16"), dual-in-line package
S	F-9 (20-Lead, 1/4" x 1/2"), flat package
2	C-2 (20-Terminal, .350" x .350"), square chip carrier package

1.3 Absolute maximum ratings.

Supply voltage range - - - - -	-0.5 V dc to +7.0 V dc
Input voltage range - - - - -	-0.5 V dc to +5.5 V dc
Storage temperature range - - - - -	-65°C to +150°C
Maximum power dissipation (P _D) ^{1/} - - - - -	880 mW
Lead temperature (soldering, 10 seconds) - - - - -	300°C
Thermal resistance, junction-to-case (θ _{JC}): 2/- - - - -	See MIL-M-38510, appendix C
Junction temperature (T _J) - - - - -	175°C/W
DC voltage applied to outputs (except during programming)-	-0.5 V to +V _{CC} maximum
DC voltage applied to outputs during programming - - - - -	21 V dc
DC current into outputs during programming (maximum duration of 1.0 seconds) - - - - -	250 mA dc
DC input current - - - - -	-30 mA to +5 mA

1.4 Recommended operating conditions.

Supply voltage (V _{CC}) - - - - -	4.5 V dc minimum to 5.5 V dc maximum
Minimum high-level input voltage (V _{IH}) - - - - -	2.0 V dc
Maximum low-level input voltage (V _{IL}) - - - - -	0.8 V dc
Case operating temperature range (T _C) - - - - -	-55°C to +125°C

^{1/} Must withstand the added P_D due to short circuit test (e.g., I_{OS}).

^{2/} Heat sinking is recommended to reduce the junction temperature.

MILITARY DRAWING DEFENSE ELECTRONICS SUPPLY CENTER DAYTON, OHIO	SIZE A	CODE IDENT. NO. 67268	DWG NO. 5962-87690
		REV	PAGE 2

2. APPLICABLE DOCUMENTS

2.1 Government specification and standard. Unless otherwise specified, the following specification and standard, of the issue listed in that issue of the Department of Defense Index of Specifications and Standards specified in the solicitation, form a part of this drawing to the extent specified herein.

SPECIFICATION

MILITARY

MIL-M-38510 - Microcircuits, General Specification for.

STANDARD

MILITARY

MIL-STD-883 - Test Methods and Procedures for Microelectronics.

(Copies of the specification and standard required by manufacturers in connection with specific acquisition functions should be obtained from the contracting activity or as directed by the contracting activity.)

2.2 Order of precedence. In the event of a conflict between the text of this drawing and the references cited herein, the text of this drawing shall take precedence.

3. REQUIREMENTS

3.1 Item requirements. The individual item requirements shall be in accordance with 1.2.1 of MIL-STD-883, "Provisions for the use of MIL-STD-883 in conjunction with compliant non-JAN devices" and as specified herein.

3.2 Design, construction, and physical dimensions. The design, construction, and physical dimensions shall be as specified in MIL-M-38510 and herein.

3.2.1 Terminal connections. The terminal connections shall be as specified on figure 1.

3.2.2 Truth table. The truth table shall be as specified on figure 2.

3.2.2.1 Unprogrammed devices. Testing to the applicable truth table, or alternate testing as specified in 4.3.1., shall be used for unprogrammed devices for contracts involving no altered item drawing. When testing is required in accordance with 4.3 herein, the devices shall be programmed by the manufacturer prior to test in a checkerboard pattern (a minimum of 50 percent of the total number of bits programmed) or to any altered item drawing pattern which includes at least 25 percent of the total number of bits programmed.

3.2.2.2 Programmed devices. The requirements for supplying programmed devices are not part of this drawing.

3.2.3 Logic diagram. The logic diagram shall be as specified on figure 3.

3.2.4 Case outlines. The case outlines shall be in accordance with 1.2.2 herein.

3.3 Electrical performance characteristics. Unless otherwise specified, the electrical performance characteristics are as specified in table I and apply over the full recommended case operating temperature range.

3.4 Marking. Marking shall be in accordance with MIL-STD-883 (see 3.1 herein). The part shall be marked with the part number listed in 1.2 herein. In addition, the manufacturer's part number may also be marked as listed in 6.4 herein.

MILITARY DRAWING DEFENSE ELECTRONICS SUPPLY CENTER DAYTON, OHIO	SIZE	CODE IDENT. NO.	DWG NO.
	A	67268	5962-87690
		REV	PAGE 3

TABLE I. Electrical performance characteristics.

Test	Symbol	Conditions -55°C < T _C ≤ +125°C 4.5 V < V _{CC} < 5.5 V (Unless otherwise specified)	Group A subgroups	Device type	Limits		Unit
					Min	Max	
Output high voltage	V _{OH}	V _{CC} = MIN, I _{OH} = -2.0 mA V _{IN} = V _{IH} or V _{IL}	1,2,3	A11	2.4		V
Output low voltage	V _{OL}	V _{CC} = MIN, I _{OH} = 16 mA V _{IN} = V _{IH} or V _{IL}	1,2,3	A11		0.50	V
Input low current	I _{IL}	V _{CC} = MAX, V _{IN} = 0.45 V	1,2,3	A11		-250	μA
Input high current	I _{IH}	V _{CC} = MAX, V _{IN} = 2.7 V	1,2,3	A11		25	μA
Output short circuit current	I _{SC}	V _{CC} = MAX, V _{OUT} = 0.0 V <u>1/</u>	1,2,3	A11	-20	-90	mA
Power supply current	I _{CC}	All inputs = GND. V _{CC} = MAX	1,2,3	A11		160	mA
Input clamp voltage	V _I	V _{CC} = MIN, I _{IN} = -18 mA	1,2,3	A11		-1.2	V
Output leakage current	I _{CEX}	V _{CC} = 5.5 V V _{CS} = 2.4 V	V _O = 5.5 V V _O = 0.4 V	1,2,3	A11	40 -40	μA μA
Address valid to output valid access time	tAVQV	See figures 4 and 5 <u>2/</u>	9,10,11	01		70	ns
				02		45	ns
Delay from output enable valid to output High-Z	tGVQZ	See figures 4 and 5 <u>3/</u>	9,10,11	01		30	ns
				02		25	ns
Delay from output enable valid to output valid	tGVQV	See figures 4 and 5 <u>3/</u>	9,10,11	01		30	ns
				02		25	ns

1/ Not more than one output should be shorted at a time. Duration of the short circuit should not be more than 1 second.

2/ tAVQV is tested with switch S1 closed and C_L = 50 pF.

3/ tGVQV is tested with C_L = 50 pF to the 1.5 V; S1 is open for high impedance to high tests and closed for high impedance to low tests. tGVQZ is tested with C_L = 5 pF. High to high impedance tests are made with S1 open to an output voltage of V_{OH} - 0.5 V. Low to high impedance tests are made with S1 closed to the V_{OL} + 0.5 V level.

MILITARY DRAWING

DEFENSE ELECTRONICS SUPPLY CENTER
DAYTON, OHIO

SIZE

A

CODE IDENT. NO.

67268

DWG NO.

5962-87690

REV

PAGE

4

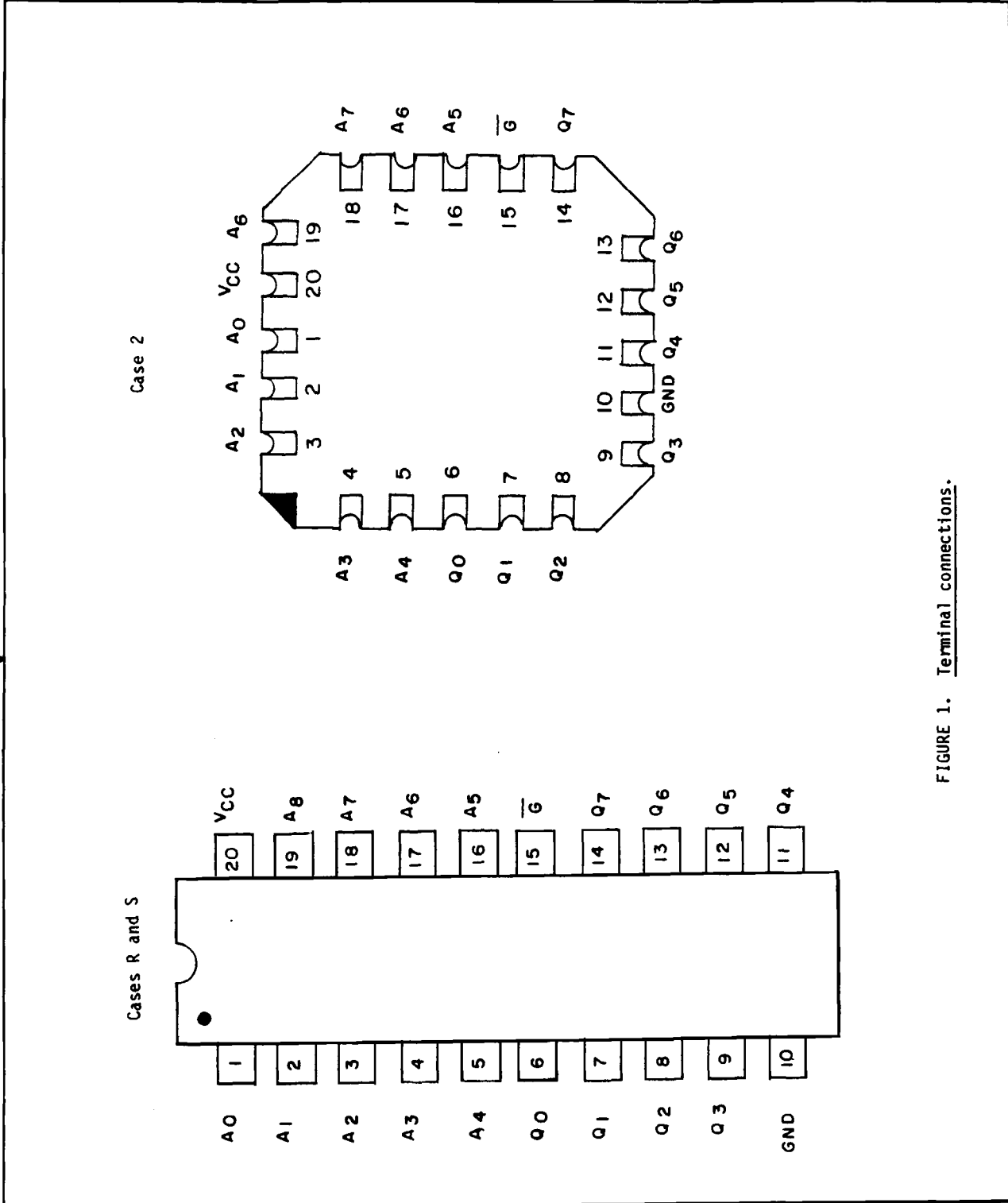

FIGURE 1. Terminal connections.

MILITARY DRAWING DEFENSE ELECTRONICS SUPPLY CENTER DAYTON, OHIO	SIZE A	CODE IDENT. NO. 67268	DWG NO. 5962-87690
		REV	PAGE 5

DESC FORM 193A
 FEB 86

Word no.	\overline{G}	Address									Data							
		A ₈	A ₇	A ₆	A ₅	A ₄	A ₃	A ₂	A ₁	A ₀	Q ₇	Q ₆	Q ₅	Q ₄	Q ₃	Q ₂	Q ₁	Q ₀
NA	H	X	X	X	X	X	X	X	X	X	OC	OC	OC	OC	OC	OC	OC	OC
	L	X	X	X	X	X	X	X	X	X	L	L	L	L	L	L	L	L

NA = Not applicable
 H = High
 L = Low
 X = Input may be high level, low level, or open circuit.
 OC = Open circuit (high resistance output).

FIGURE 2. Truth table.

MILITARY DRAWING DEFENSE ELECTRONICS SUPPLY CENTER DAYTON, OHIO	SIZE A	CODE IDENT. NO. 67268	DWG NO. 5962-87690
		REV	PAGE 6

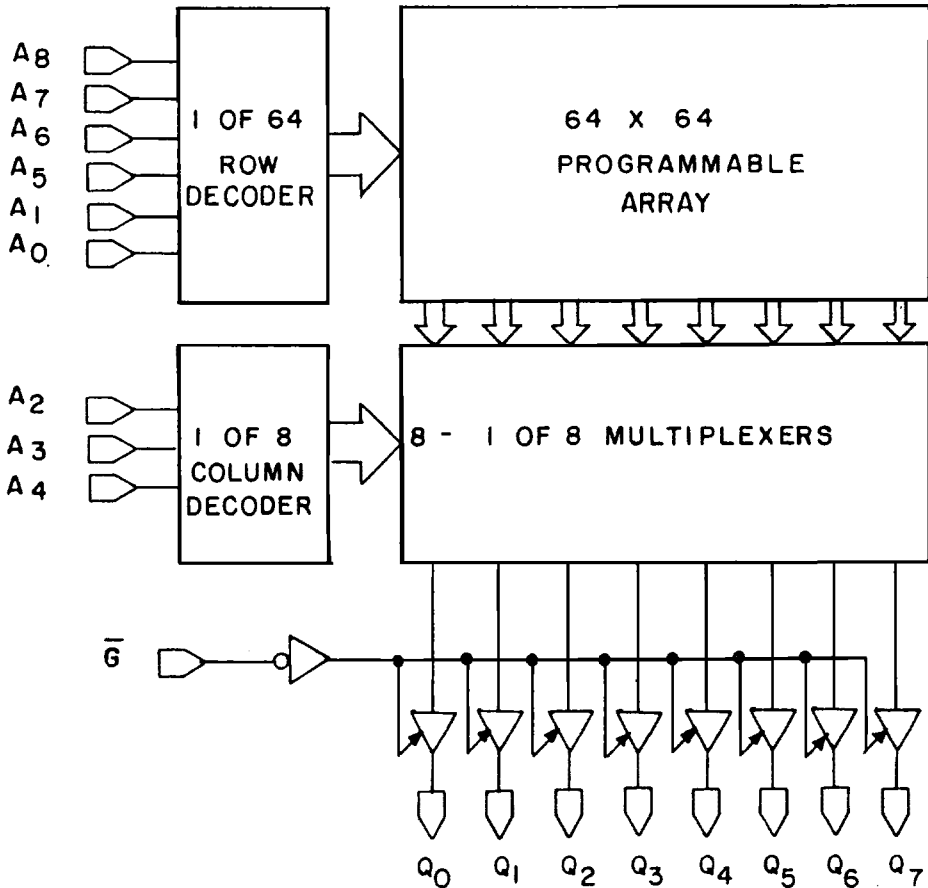
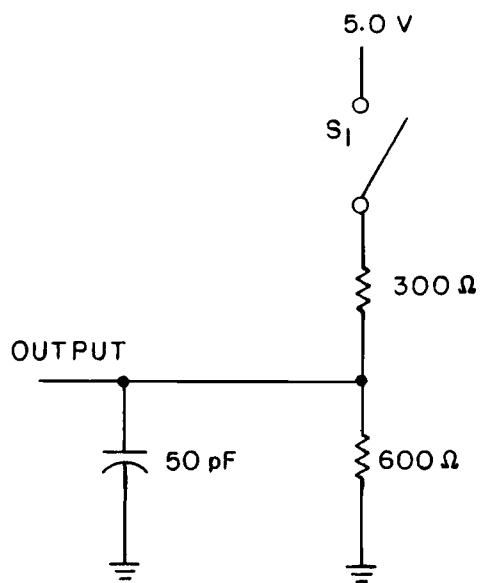
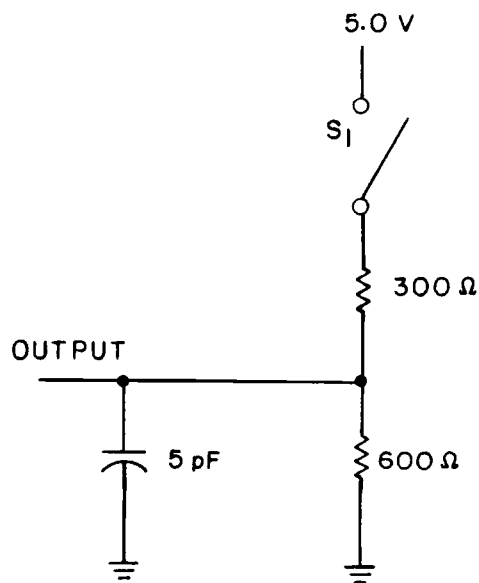

FIGURE 3. Logic diagram.

MILITARY DRAWING DEFENSE ELECTRONICS SUPPLY CENTER DAYTON, OHIO	SIZE	CODE IDENT. NO.	DWG NO.
	A	67268	5962-87690
	REV	PAGE	7



A. Output load for all A-C tests, except TGVQZ.



B. Output load for TGVQZ

NOTES:

1. All device test loads should be located within 2 inches of device output pin.
2. S_1 is open for output data HIGH to Hi-Z and Hi-Z to output data HIGH tests.
 S_1 is closed for all other ac tests.
3. Load capacitance includes all stray and fixture capacitance.

FIGURE 4. Switching test circuit.

MILITARY DRAWING DEFENSE ELECTRONICS SUPPLY CENTER DAYTON, OHIO	SIZE A	CODE IDENT. NO. 67268	DWG NO. 5962-87690
		REV	PAGE 8

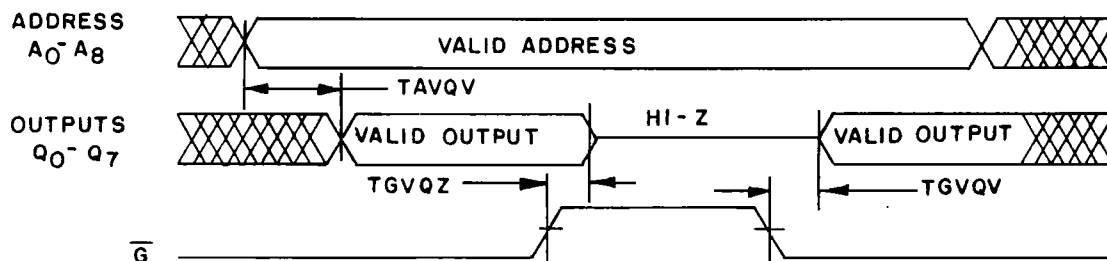

KEY TO SWITCHING WAVEFORMS

WAVEFORM	INPUTS	OUTPUTS
	MUST BE STEADY	WILL BE STEADY
	MAY CHANGE FROM H TO L	WILL BE CHANGING FROM H TO L
	MAY CHANGE FROM L TO H	WILL BE CHANGING FROM L TO H
	DONT CARE: ANY CHANGE PERMITTED	CHANGING STATE UNKNOWN
	DOES NOT APPLY	CENTER LINE IS HIGH IMPEDANCE "OFF" STATE

FIGURE 5. Switching waveforms.

MILITARY DRAWING DEFENSE ELECTRONICS SUPPLY CENTER DAYTON, OHIO	SIZE A	CODE IDENT. NO. 67268	DWG NO. 5962-87690
		REV	PAGE 9

3.5 Processing options. Since the PROM is an unprogrammed memory capable of being programmed by either the manufacturer or the user to result in a wide variety of PROM configurations, two processing options are provided for selection in the contract, using an altered item drawing.

3.5.1 Unprogrammed PROM delivered to the user. All testing shall be verified through group A testing as defined in 4.3.1. It is recommended that users perform subgroups 7 and 9 after programming to verify the specific program configuration.

3.5.2 Manufacturer-programmed PROM delivered to the user. All testing requirements and quality assurance provisions herein, including the requirements of the altered item drawing, shall be satisfied by the manufacturer prior to delivery.

3.6 Certificate of compliance. A certificate of compliance shall be required from a manufacturer in order to be listed as an approved source of supply in 6.4. The certificate of compliance submitted to DESC-ECS prior to listing as an approved source of supply shall state that the manufacturer's product meets the requirements of MIL-STD-883 (see 3.1 herein) and the requirements herein.

3.7 Certificate of conformance. A certificate of conformance as required in MIL-STD-883 (see 3.1 herein) shall be provided with each lot of microcircuits delivered to this drawing.

3.8 Notification of change. Notification of change to DESC-ECS shall be required in accordance with MIL-STD-883 (see 3.1 herein).

3.9 Verification and review. DESC, DESC's agent, and the acquiring activity retain the option to review the manufacturer's facility and applicable required documentation. Offshore documentation shall be made available onshore at the option of the reviewer.

4. QUALITY ASSURANCE PROVISIONS

4.1 Sampling and inspection. Sampling and inspection procedures shall be in accordance with section 4 of MIL-M-38510 to the extent specified in MIL-STD-883 (see 3.1 herein).

4.2 Screening. Screening shall be in accordance with method 5004 of MIL-STD-883, and shall be conducted on all devices prior to quality conformance inspection. The following additional criteria shall apply:

a. Burn-in test (method 1015 of MIL-STD-883).

(1) Test condition C or D using the circuit submitted with the certificate of compliance (see 3.6 herein).

(2) $T_A = +125^{\circ}\text{C}$, minimum.

b. Interim and final electrical test parameters shall be as specified in table II herein, except interim electrical parameter tests prior to burn-in are optional at the discretion of the manufacturer.

4.3 Quality conformance inspection. Quality conformance inspection shall be in accordance with method 5005 of MIL-STD-883 including groups A, B, C, and D inspections. The following additional criteria shall apply.

4.3.1 Group A inspection.

a. Tests shall be as specified in table II herein.

b. Subgroups 4, 5, and 6 in table I, method 5005 of MIL-STD-883 shall be omitted.

MILITARY DRAWING DEFENSE ELECTRONICS SUPPLY CENTER DAYTON, OHIO	SIZE A	CODE IDENT. NO. 67268	DWG NO. 5962-87690
		REV	PAGE 10

TABLE II. Electrical test requirements.

MIL-STD-883 test requirements	Subgroups (per method 5005, table I)
Interim electrical parameters (method 5004)	---
Final electrical test parameters (method 5004)	1*,2,3,7*,8,9 10,11**
Group A test requirements (method 5005)	1,2,3,7,8,9, 10,11**
Groups C and D end-point electrical parameters (method 5005)	1,2,3
Additional electrical subgroups for group C periodic inspection	---

*PDA applies to subgroups 1 and 7.

**Subgroups 10 and 11, if not tested, shall be guaranteed to the limits specified in table I.

c. Unprogrammed devices shall be tested for programmability and ac performance compliance to the requirements of group A, subgroup 9, 10, and 11. Either of two techniques is acceptable.

(1) Additional built-in test circuitry which allows the manufacturer to verify programmability and ac performance without programming the user array. If this is done, the resulting test patterns shall be verified on all devices in group A sample testing, per MIL-STD-883, method 5005, group A, subgroups 9, 10, 11.

(2) If such compliance cannot be tested on an unprogrammed device, a sample shall be selected to satisfy programmability requirements prior to performing subgroups 9, 10, 11. Twelve devices shall be submitted to programming (see 3.2.2.1). If more than two devices fail to program, the lot shall be rejected. At the manufacturer's option, the sample may be increased to 24 total devices with no more than four total devices failures allowed. Ten devices from the programmability sample shall be submitted to the requirements of group A, subgroup 9, 10, 11. If more than two total devices fail, the lot shall be rejected. At the manufacturer's option, the sample may be increased to 20 total devices with no more than four total device failures allowable.

d. Subgroups 7 and 8 must verify input to output logic combinations.

4.3.2 Groups C and D inspections.

a. End-point electrical parameters shall be as specified in table II herein.

b. Steady-state life test (method 1005 of MIL-STD-883) conditions:

(1) Test condition C or D using the circuit submitted with the certificate of compliance (see 3.5 herein).

(2) $T_A = +125^\circ\text{C}$, minimum.

(3) Test duration: 1,000 hours, except as permitted by appendix B of MIL-M-38510 and method 1005 of MIL-STD-883.

MILITARY DRAWING DEFENSE ELECTRONICS SUPPLY CENTER DAYTON, OHIO	SIZE A	CODE IDENT. NO. 67268	DWG NO. 5962-87690
		REV	PAGE 11

c. The group C, subgroup 1 sample shall include devices tested in accordance with 4.3.1c.

4.4 Programming procedure for method A. The programming characteristics of table III and the following procedures shall be used for programming the device.

- a. Connect the device in the electrical configuration for programming. The waveforms on figure 6 and the programming characteristics of table III shall apply to these procedures.
- b. Terminate all outputs to V_{ONP} through a pull-up resistor R.
- c. Apply V_{CCP} to V_{CC} .
- d. Connect \overline{CS} to V_{ILP} .
- e. Address the PROM with the binary address of the selected word to be programmed.
- f. After a delay of T_1 , apply V_{OP} for a duration of T_p + rise time of \overline{CS}_1 input + T_2 to the output selected for programming. After a delay of T_2 + rise time of programmed output, apply V_{CSP} for a duration of T_p + rise time of programmed output + T_3 to the \overline{CS} input; \overline{CS} is then reduced to V_{ILP} .
- g. After a delay of T_4 , opening of the fuse is verified. During verification, V_{CC} remains unchanged at V_{CCP} .
- h. The outputs should be programmed one at a time, since the internal decoding circuitry is capable of sinking only one unit of programming current at a time. Note that the PROM is supplied with fuses generating a low-level logic output. Programming a fuse will cause the output to go to a high level logic in the verify mode.
- i. Repeat steps 4.4a through 4.4g for all bits to be programmed.
- j. If any unit does not verify as programmed, it shall be considered a programming reject.

MILITARY DRAWING

DEFENSE ELECTRONICS SUPPLY CENTER
DAYTON, OHIO

SIZE

A

CODE IDENT. NO.

67268

DWG NO.

5962-87690

REV

PAGE 12

TABLE III. Programming characteristics for method A.

Test	Symbol	Conditions $T_C = +25^\circ\text{C}$	Limits		Units
			Min	Max	
V _{CC} during programming	V _{CCP}		5.0	5.5	V
High level input voltage during programming	V _{IHP}		2.4	5.5	V
Low level input voltage during programming	V _{ILP}		0.0	0.45	V
Chip select voltage during programming	V _{CSP}		14.5	15.5	V
Output voltage during programming	V _{OP}		19.5	20.5	V
Voltage on outputs not to be programmed	V _{ONP}		0	V _{CCP} +0.3	V
Current in outputs not to be programmed	I _{ONP}			20	mA
Rate of output voltage change	$\frac{d(V_{OP})}{dt}$		20	250	V/ μs
Rate of chip select voltage change	$\frac{d(V_{CS})}{dt}$		100	1000	V/ μs
Programming period	t _p		50	100	μs

MILITARY DRAWING

DEFENSE ELECTRONICS SUPPLY CENTER
DAYTON, OHIO

SIZE

A

CODE IDENT. NO.

67268

DWG NO.

5962-87690

REV

PAGE

13

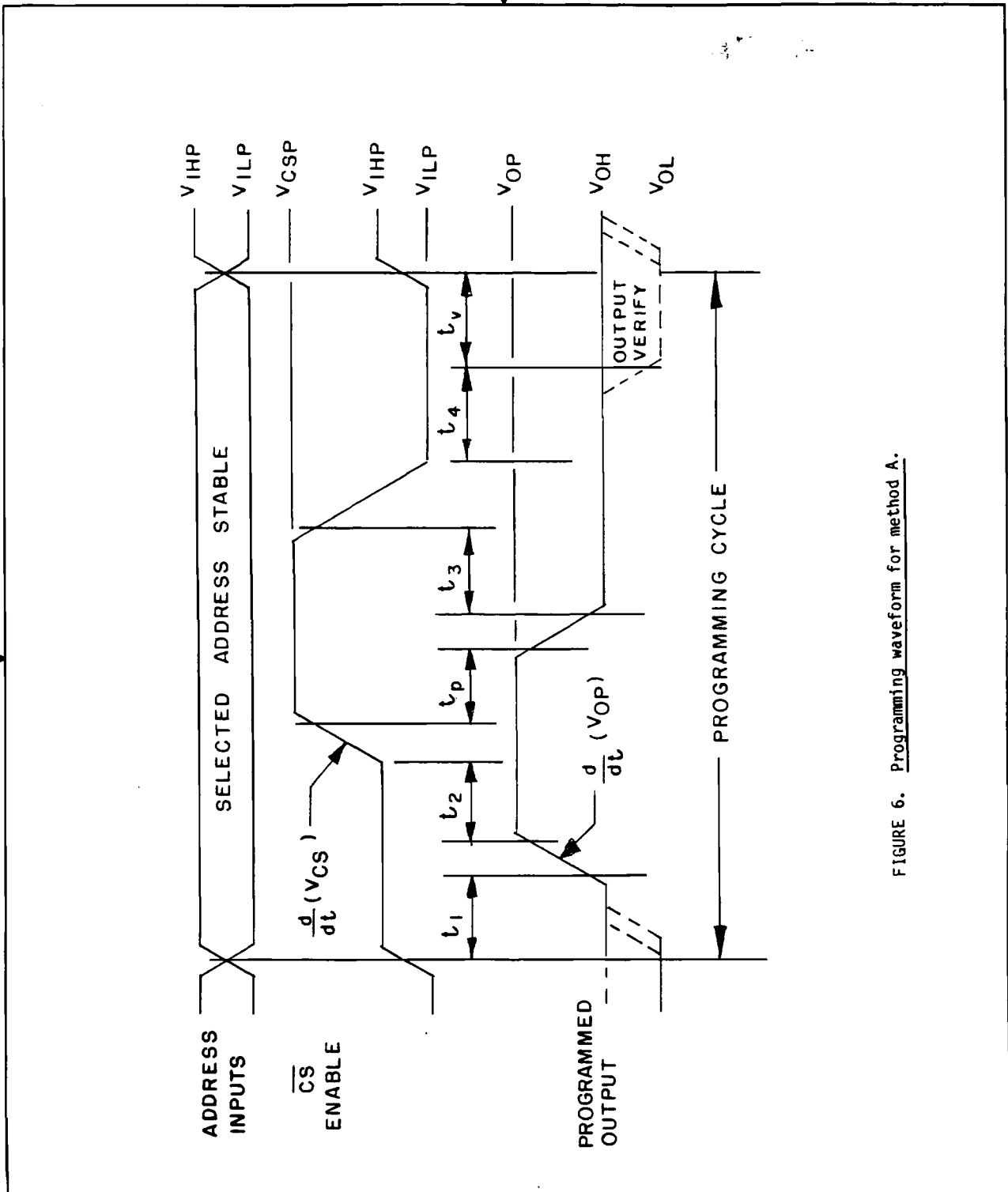

FIGURE 6. Programming waveform for method A.

MILITARY DRAWING DEFENSE ELECTRONICS SUPPLY CENTER DAYTON, OHIO	SIZE A	CODE IDENT. NO. 67268	DWG NO. 5962-87690
		REV	PAGE 14

5. PACKAGING

5.1 Packaging requirements. The requirements for packaging shall be in accordance with MIL-M-38510.

6. NOTES

6.1 Intended use. Microcircuits conforming to this drawing are intended for use when military specifications do not exist and qualified military devices that will perform the required function are not available for OEM application. When a military specification exists and the product covered by this drawing has been qualified for listing on QPL-38510, the device specified herein will be inactivated and will not be used for new design. The QPL-38510 product shall be the preferred item for all applications.

6.2 Replaceability. Microcircuits covered by this drawing will replace the same generic device covered by a contractor-prepared specification or drawing.

6.3 Comments. Comments on this drawing should be directed to DESC-ECS, Dayton, Ohio 45444, or telephone 513-296-5375.

6.4 Approved source of supply. An approved source of supply is listed herein. Additional sources will be added as they become available. The vendor listed herein has agreed to this drawing and a certificate of compliance (see 3.6 herein) has been submitted to DESC-ECS.

Military drawing part number	Vendor CAGE number	Vendor similar part number ^{1/}	Replacement military specification part number
5962-8769001RX	34335	AM27S29/BRA	---
5962-8769001SX	34335	AM27S29/BSA	---
5962-87690012X	34335	AM27S29/B2A	---
5962-8769002RX	34335	AM27S29A/BRA	---
5962-8769002SX	34335	AM27S29A/BSA	---
5962-87690022X	34335	AM27S29A/B2A	---

^{1/} Caution. Do not use this number for item acquisition. Items acquired to this number may not satisfy the performance requirements of this drawing.

<u>Vendor CAGE number</u>	<u>Vendor name and address</u>	<u>Programming Procedure</u>	<u>Fusable line</u>
34335	Advanced Micro Devices, Inc. 901 Thompson Place P.O. Box 3453 Sunnyvale, CA 94088	A	Platinum silicide fuse

MILITARY DRAWING DEFENSE ELECTRONICS SUPPLY CENTER DAYTON, OHIO	SIZE A	CODE IDENT. NO. 67268	DWG NO. 5962-87690
		REV	PAGE 15

