

REVISIONS			
REV.	DESCRIPTION	DATE	APPROVED
A	INITIAL RELEASE	09/14/09	A.D.M.

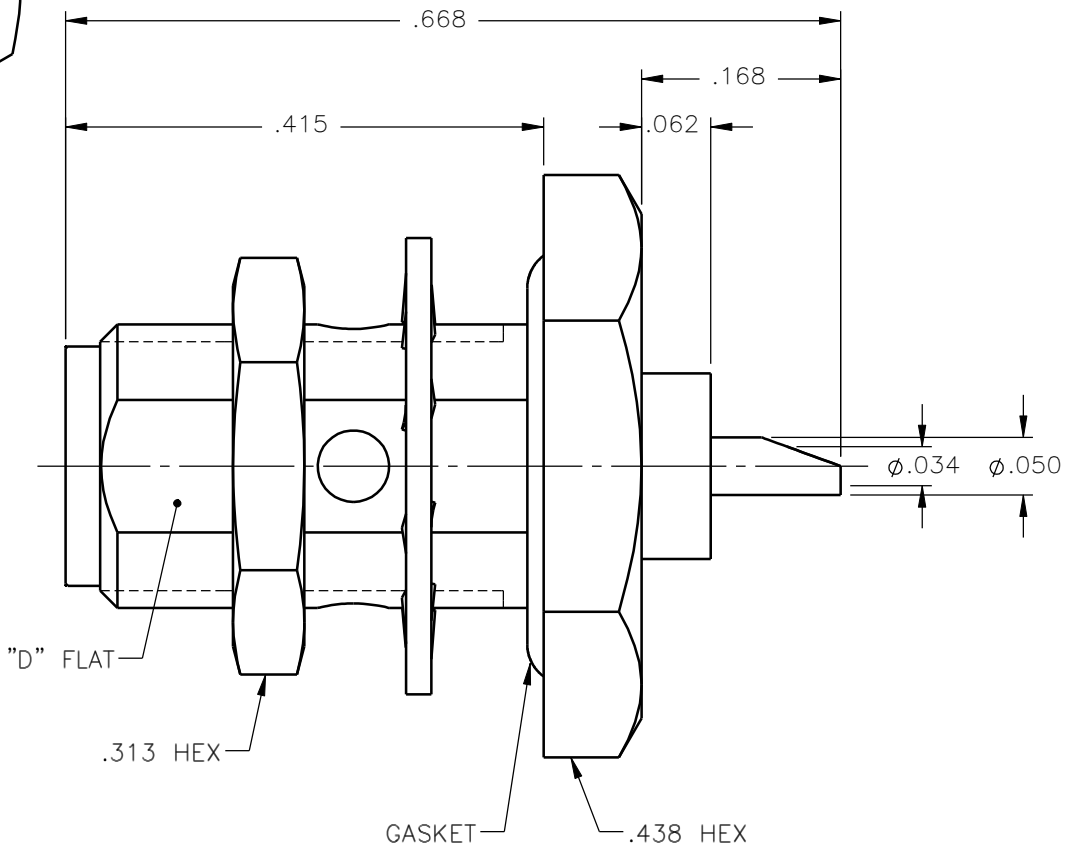
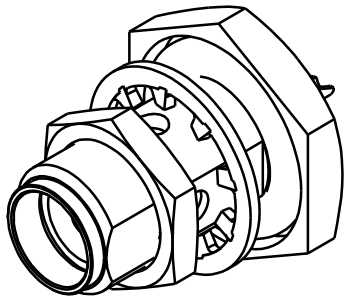

NOTES:

MATERIALS:

1. BODY & NUT = STAINLESS STEEL PER ASTM A582, ALLOY 303, CONDITION "A".
2. INSULATOR = VIRGIN WHITE TEFLON PER ASTM D1710, GRADE 1, TYPE I, CLASS "B".
3. CONTACT = BERYLLIUM COPPER PER ASTM B196, ALLOY C17300, TEMPER TD04.
4. LOCKWASHER = PHOSPHOR BRONZE PER ASTM B139, COPPER ALLOY C53400, TEMPER H04.
5. GASKET = SILICONE RUBBER PER ZZ-R-765, CLASS 2B, GRADE 65-75.

FINISHES:

1. BODY & NUT = GOLD PLATE PER MIL-G-45204, TYPE II, CLASS 0, GRADE C, OVER .000050 TO .00010 STRESS FREE NICKEL PER QQ-N-290.
2. CONTACT = GOLD PLATE PER MIL-G-45204, TYPE II, CLASS 1, GRADE C, OVER .00010 TO .00020 STRESS FREE SULFAMATE NICKEL PER QQ-N-290.
3. LOCKWASHER = GOLD PLATE PER MIL-G-45204, TYPE II, CLASS 0, GRADE C, OVER .00010 TO .00020 COPPER STRIKE PER MIL-C-14550.

Property of Radiall Incorporated  
 This document cannot be reproduced or  
 communicated to a third party without prior  
 written permission of RADIALL Incorporated.

UNLESS OTHERWISE SPECIFIED DIMENSIONS ARE IN INCHES TOLERANCES ON	DWN: A.D.M.	DATE 09/14/09	 <b>APPLIED ENGINEERING PRODUCTS</b> 104 John W. Murphy Dr. New Haven, CT 06513 <b>a RADIALL company</b>		
	CHKD: D.N.	DATE 09/14/09			
	APVD: J.M.	DATE 09/14/09			
DECIMAL	ANGLE	<b>SMA STRAIGHT JACK          BULKHEAD/REAR MOUNT          SOLDER POT RECEPTACLE</b>			
REFERENCE:	MATERIALS & FINISHES: SEE NOTES				SIZE A
ORIGINATED: A.D.M. DATE: 09/14/09	SCALE 6:1		THIRD ANGLE PROJECTION		SHEET 1 OF 1

9432-1113-000