

# Grove - ADC for Load Cell (HX711)

SKU 101020712

The Grove - ADC for Load Cell (HX711) is a 24-bit A/D converter designed specifically for the load cell, it's quite easy to build your Arduino weight sensor system with this module.

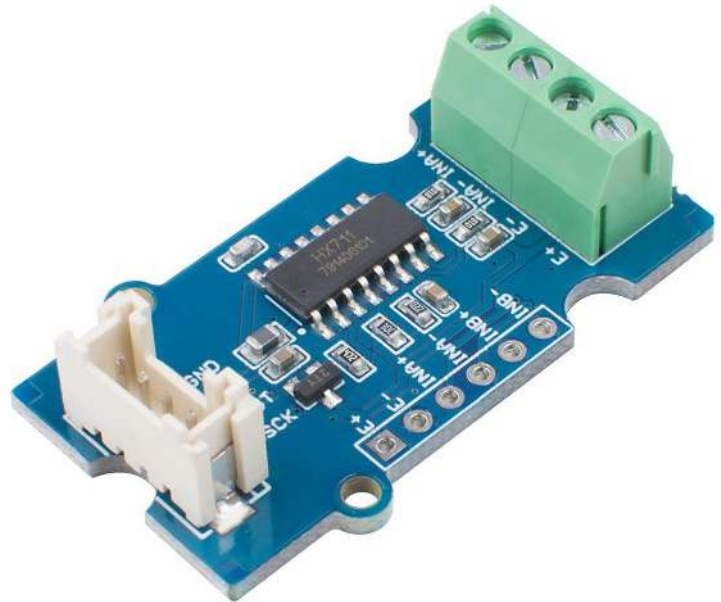

## PRODUCT DETAILS

Well, you can find more than a dozen [load cells](#) on Seeed Bazaar, however, it is never going to be easy to use these load cells to measure weight. Let's see, you need to find a proper ADC and stable power source, then do some wiring and calibration, at last, you still need to do the coding... Time is long, life is short, Grove - ADC for Load Cell is born to save your time and make it easy to use load cells. How easy? Easy and peasy!

The Grove - ADC for Load Cell (HX711) is a 24-bit A/D converter designed specifically for the load cell. It contains an on-chip low noise programmable amplifier with an optional gain of 32, 64 and 128. The HX711 chip integrates a regulated power supply, an on-chip clock oscillator, and other peripheral circuits, which have the advantages of high integration, fast response, and strong anti-interference.

With the Grove connector and 4-pin screw terminal, it becomes quite easy to connect the load cell and microcontroller, no soldering required. You can build your own Arduino weigh sensor system in just a few simple steps.

## Features

- Working voltage: 2.6V--5.5V (Note: The module measurement accuracy is related to the supply voltage. The higher the voltage, the higher the accuracy.)
- Working current: <1.5mA
- Detection accuracy: 24 bits
- Optional 10SPS or 80SPS output data rate
- Optional gain: 32 for Channel B / 64 and 128 for Channel A

## Hardware Overview

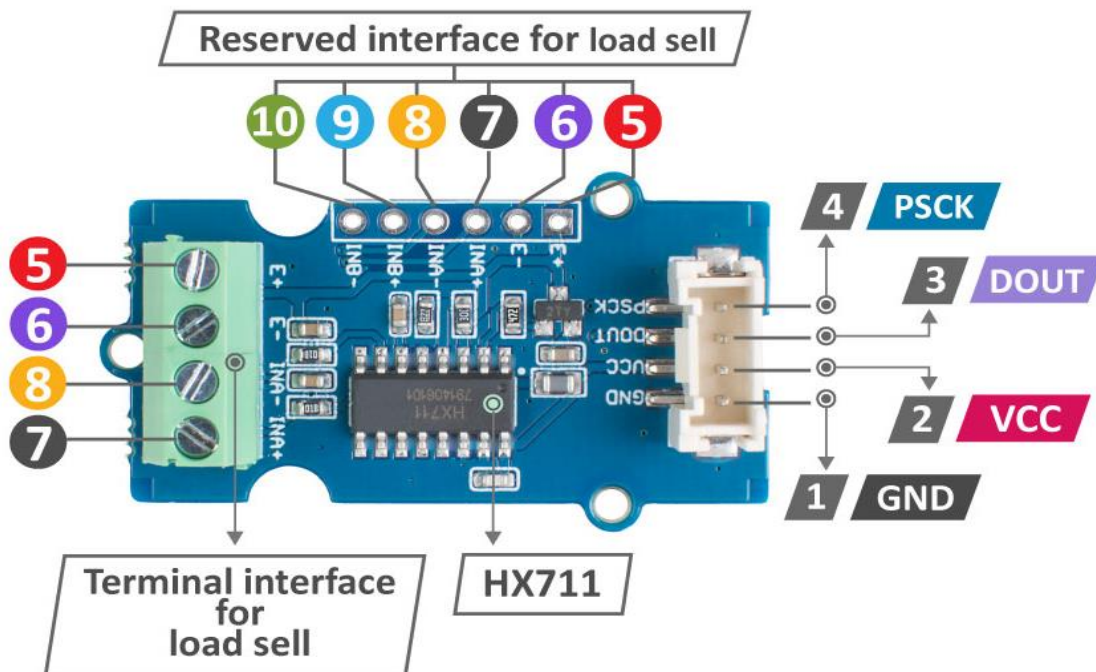

**1** : Connected to the system GND

**2** : Power supply from grove 5V/3.3V\*2

**3** : Serial data output

**4** : Serial clock input

**5** : Load sell excitation

power supply positive

**6** : Load sell excitation

power supply negative

**7** : Channel A positive input

**8** : Channel A negative input

**9** : Channel B positive input

**10** : Channel B negative input



### Tip

- Channel A is for weight measurement, it has a programmable gain of 128 or 64.
- Channel B is used for system parameter detection, it has a fixed 32 gain

## ECCN/HTS

|          |            |
|----------|------------|
| HSCODE   | 8543709990 |
| USHSCODE | 8517620090 |
| UPC      |            |

## LEARN AND DOCUMENTS

### *Documentations*

**Grove - ADC for load cell (HX711)-Schematic File  
HX711-datasheet**

### *Learn*



**[Others] 10 THINGS YOU CAN DO WITH YOUR HX711 AND LOAD CELL**

In this blog we will show you 10 cool project that you can make with HX711 and load cell.

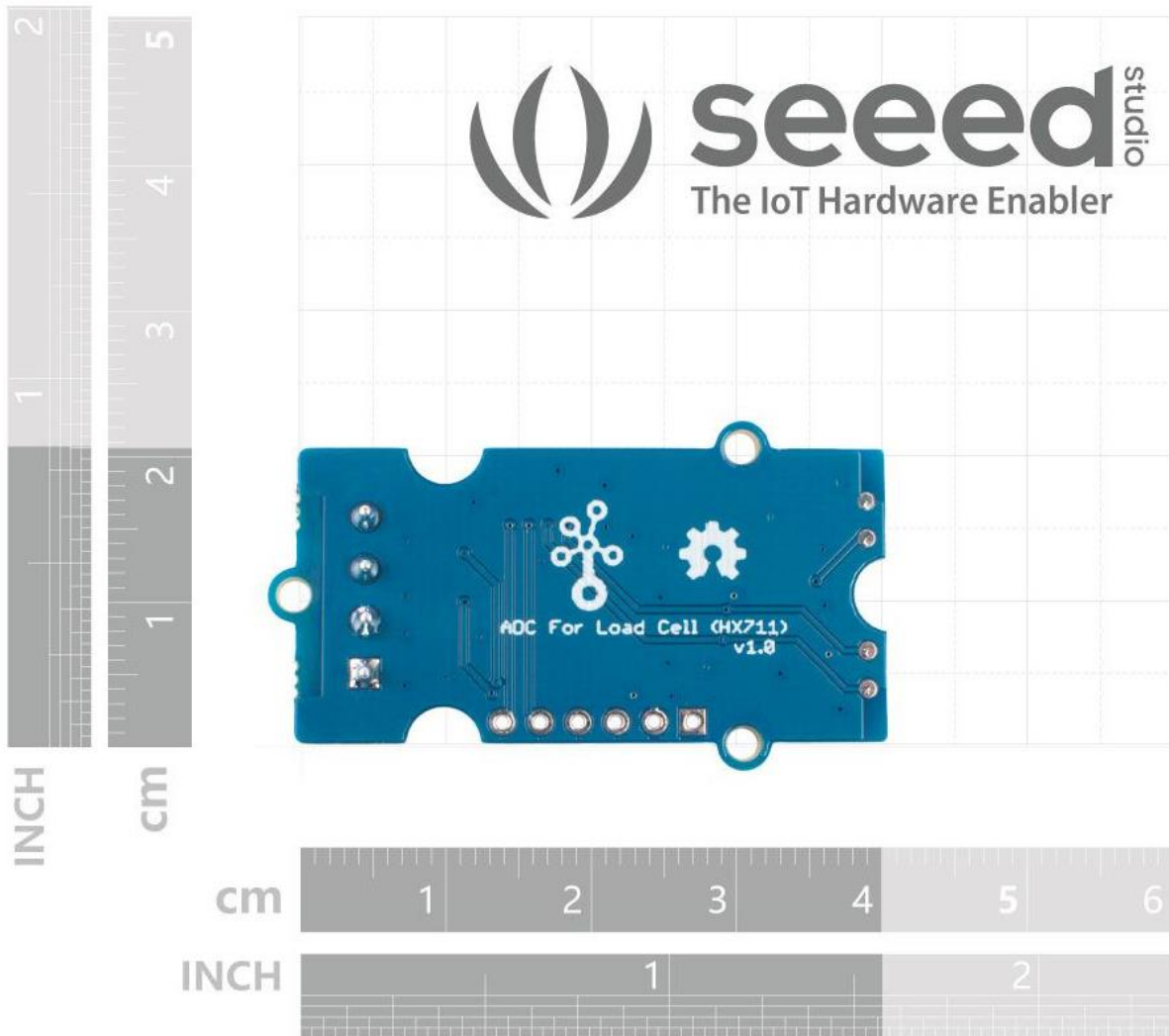
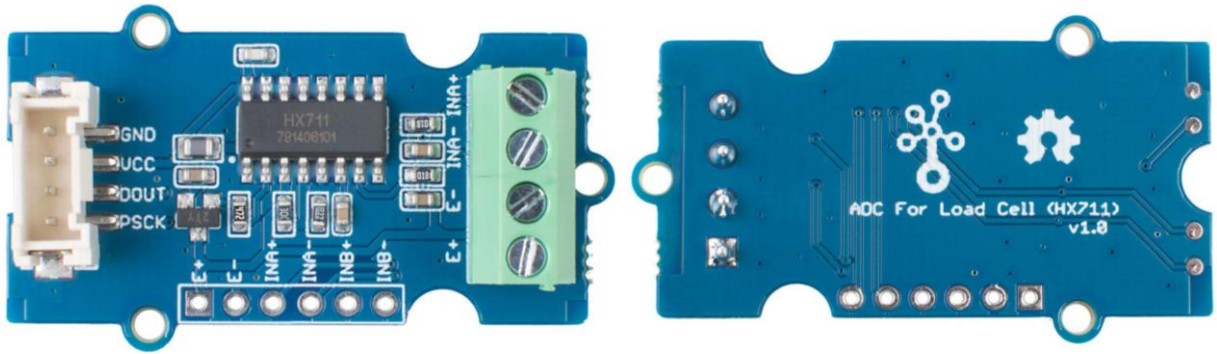

<https://www.seeedstudio.com/Grove-ADC-for-Load-Cell-HX711-p-4361.html/12-12-21>