

REVISIONS					
P	LTR	DESCRIPTION	DATE	DWN	APVD
	AT3	REVISED PER ECR-22-150475	26AUG2022	RK	MZ

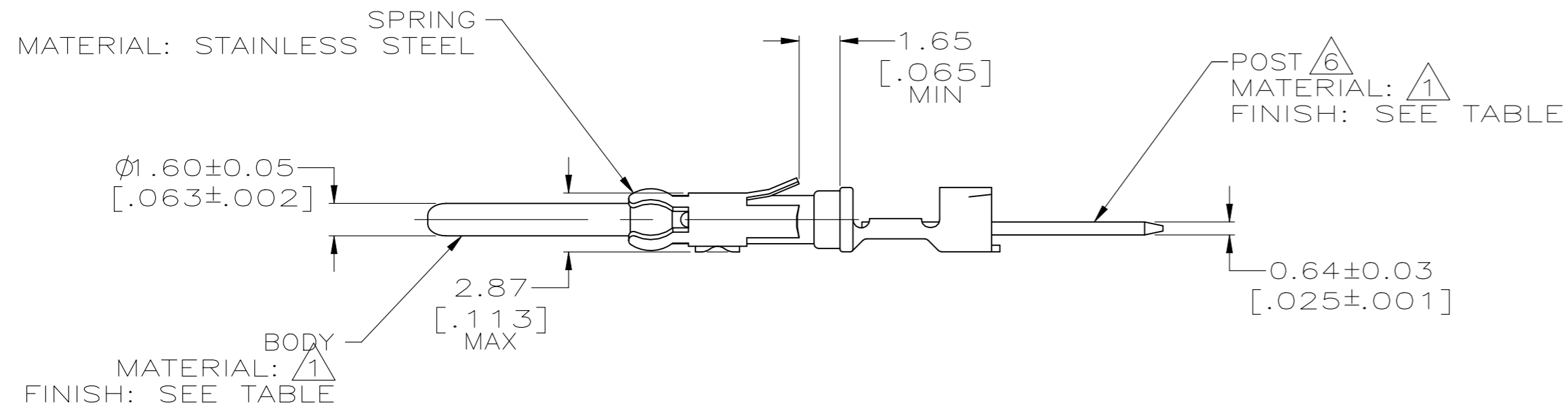
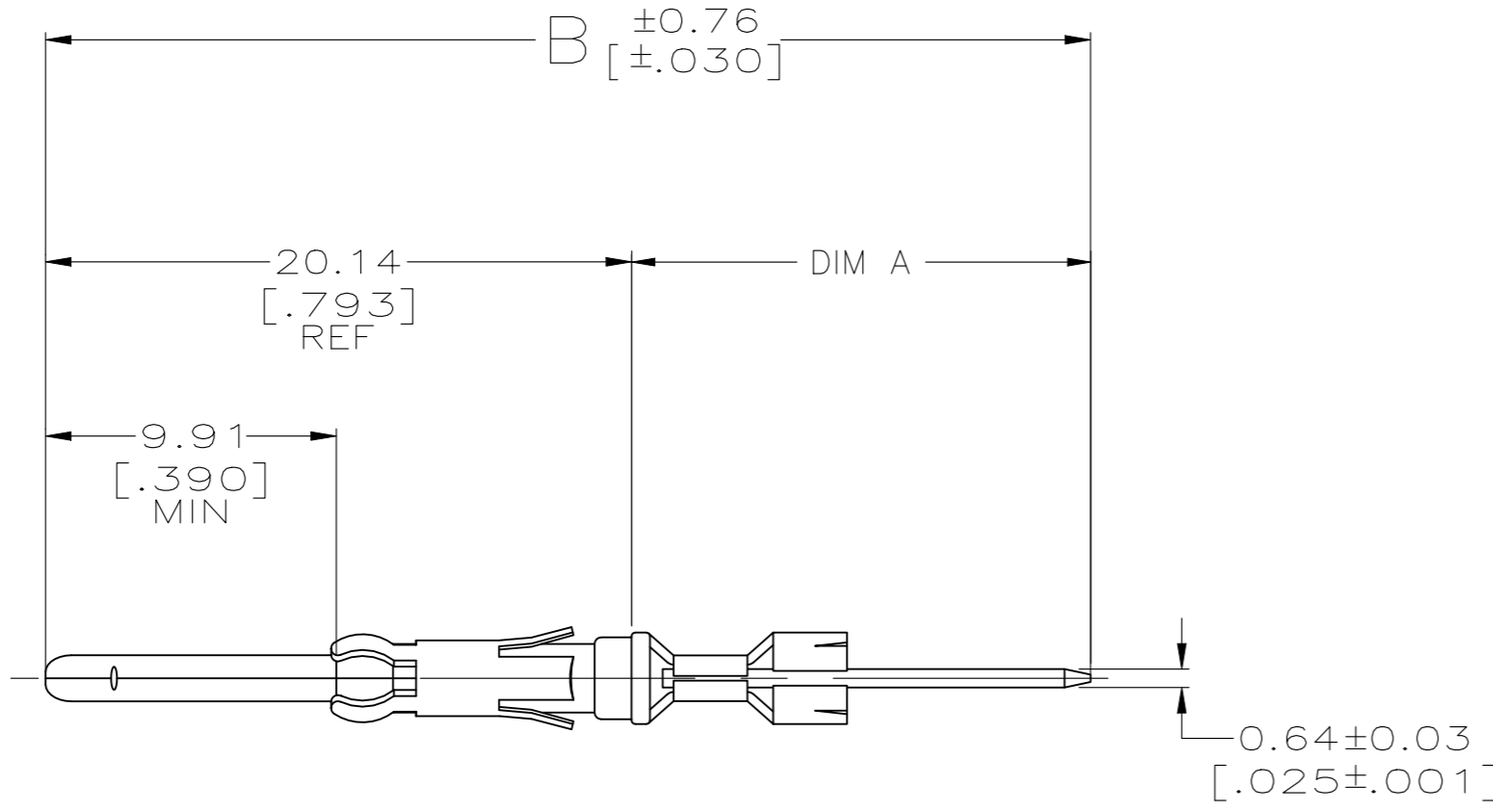

- ① BRASS PER ASTM B-36.
- ② 2.54µm [.000100] MIN TIN-LEAD OVER 1.27µm [.000050] MIN NICKEL.
- ③ 0.76µm [.000030] MIN PRECIOUS METAL PLATING CONFORMS TO THE REQUIREMENTS OF TE PRODUCT SPEC 108-10042, BASED ON EIA/ECA-364-1000.01 (CONTROLLED ENVIRONMENT APPLICATIONS), OVER 1.27µm [.000050] MIN NICKEL.
- ④ 0.76µm [.000030] MIN PRECIOUS METAL PLATE ON MATING END FOR A LENGTH OF 5.08 [.200] MIN OVER 1.27µm [.000050] MIN NICKEL PLATE. GOLD FLASH ALL OVER. CONFORMS TO THE REQUIREMENTS OF TE CONNECTIVITY PRODUCT SPEC 108-10042, BASED ON EIA/ECA-364-1000.01A (CONTROLLED ENVIRONMENT APPLICATIONS).
- ⑤ SELECTIVELY PLATED 0.51µm [.000020] MIN GOLD, FOR A DISTANCE OF 5.08 [.200] FROM MATING END, GOLD FLASH ON REMAINDER, ALL OVER 0.76µm [.000030] MIN NICKEL.
- ⑥ POST WILL ACCEPT (SEE TABLE) TERMINATIONS.
- ⑦ POST PLATING .000100 MIN TIN OVER .000050 MIN NICKEL.
- ⑧ .0001000 TIN OVER .000050 NICKEL.

FINISH	BODY FINISH	NO OF TERM	B	A	PART NUMBER	
⑦	⑧	3	46.08 [1.814]	25.91 [1.020]	6-66460-6	
⑦	⑧	1	35.97 [1.416]	15.80 [.622]	6-66460-5	
⑦	④	3	46.08 [1.814]	25.91 [1.020]	6-66460-4	
⑦	④	2	41.28 [1.625]	21.11 [.831]	6-66460-3	
⑦	④	1	35.97 [1.416]	15.80 [.622]	6-66460-2	
OBSOLETE	②	②	SPECIAL	33.40 [1.315]	13.23 [.521]	6-66460-1
	②	③	SPECIAL	65.61 [2.583]	45.44 [1.789]	5-66460-0
	②	③	SPECIAL	57.73 [2.273]	37.57 [1.479]	4-66460-9
	②	③	SPECIAL	49.86 [1.963]	29.69 [1.169]	4-66460-8
	②	③	SPECIAL	68.60 [2.701]	48.44 [1.907]	3-66460-0
	②	③	SPECIAL	59.71 [2.351]	39.55 [1.557]	2-66460-9
	②	③	SPECIAL	50.82 [2.001]	30.66 [1.207]	2-66460-8
OBSOLETE	②	④	1	34.80 [1.370]	14.63 [.576]	2-66460-1
	②	④	-	34.77 [1.369]	14.63 [.576]	2-66460-0
	②	④	SPECIAL	52.78 [2.078]	32.61 [1.284]	1-66460-9
OBSOLETE	②	⑤	2	41.28 [1.625]	21.11 [.831]	1-66460-8
	②	④	2	41.28 [1.625]	21.11 [.831]	1-66460-1
	②	④	SPECIAL	33.40 [1.315]	13.23 [.521]	1-66460-0
	②	④	3	46.08 [1.814]	25.91 [1.020]	66460-9
	②	④	2	41.28 [1.625]	21.11 [.831]	66460-8
	②	④	1	35.97 [1.416]	15.80 [.622]	66460-7
OBSOLETE	②	③	3	46.08 [1.814]	25.91 [1.020]	66460-6
SUPERSEDED BY 66460-8	②	③	2	41.28 [1.625]	21.11 [.831]	66460-5
OBSOLETE	②	③	1	35.97 [1.416]	15.80 [.622]	66460-4
OBSOLETE	②	②	3	46.08 [1.814]	25.91 [1.020]	66460-3
	②	②	2	41.28 [1.625]	21.11 [.831]	66460-2
	②	②	1	35.97 [1.416]	15.80 [.622]	66460-1

THIS DRAWING IS A CONTROLLED DOCUMENT.

DWN: C. REIFSNYDER 06 JUN 96
 CHK: R. STONE 27 JUN 96
 APVD: G.A. STEINHAUER 23 JUL 96

TE Connectivity Ltd. PIN CONTACT, CRIMPED, .062, .025 X .025 POSST, M SERIES

DIMENSIONS: MM [INCHES]	TOLERANCES UNLESS OTHERWISE SPECIFIED:	0 PLC ± -	1 PLC ± -	2 PLC ± 0.25 [010]	3 PLC ± -	4 PLC ± -	ANGLES ± -	MATERIAL: SEE CALLOUTS	FINISH: SEE CALLOUTS	WEIGHT: -	SIZE: A2	CAGE CODE: 00779	DRAWING NO: C-66460	RESTRICTED TO: -
CUSTOMER DRAWING										SCALE: 4:1	SHEET: 1 of 2	REV: AT3		

REVISIONS				
P	LTR	DESCRIPTION	DATE	APVD
-	-	SEE SHEET 1	-	-

		SPECIAL	33.40 [1.315]	13.23 [.521]	6-66460-8
		2	41.28 [1.625]	21.11 [.831]	6-66460-7
POST FINISH	BODY FINISH	NO OF TERM	B	A	PART NUMBER

THIS DRAWING IS A CONTROLLED DOCUMENT.		DWN C.REIFSNYDER 06 JUN 96	TE Connectivity Ltd.		
DIMENSIONS: MM [INCHES]		CHK R.STONE 27 JUN 96			
TOLERANCES UNLESS OTHERWISE SPECIFIED:		APVD G.A.STEINHAUER 23 JUL 96	NAME PIN CONTACT, CRIMPED, .062, .025 X .025 POSST, M SERIES		
 0 PLC ± - 1 PLC ± - 2 PLC ± 0.25 [.010] 3 PLC ± - 4 PLC ± - ANGLES ± -		PRODUCT SPEC -	SIZE A2	CAGE CODE 00779	DRAWING NO C-66460
MATERIAL SEE CALLOUTS		FINISH SEE CALLOUTS	WEIGHT	RESTRICTED TO -	
CUSTOMER DRAWING			SCALE 4:1	SHEET 2 of 2	REV AT3