

PRODUCT SPECIFICATION DRAWING

P2RFD-1672-SS

FINISH:
BODIES &
COMPONENTS: WHITE BRONZE

CONTACT & PIN: SILVER

PERFORMANCE:
IMPEDANCE: 50 OHMS
Vp: 77%
FREQ. RANGE: DC TO 7.5 GHz
DELAY: 166ps
VSWR: <1.10:1 @ DC-7.5 GHz
INSERTION LOSS: <-.1db @ 7.5 GHz
3rd ORDER IM: <-160 dBc IN PCS BAND w/2+43 dB TONES
N TORQUE: 10 inLb
OPERATING TEMP RANGE: -55°C TO +150°C

MATERIAL:
BODIES,
COMPONENTS
& PIN: BRASS

HEX NUT: STAINLESS STEEL PER AMS-5640, TYPE 303,
COND. A

CONTACT: BERYLLIUM COPPER

GASKET: SILICONE RUBBER, ZZ-R-765 DUROMETER 70

INSULATOR: PTFE PER ASTM-D1710

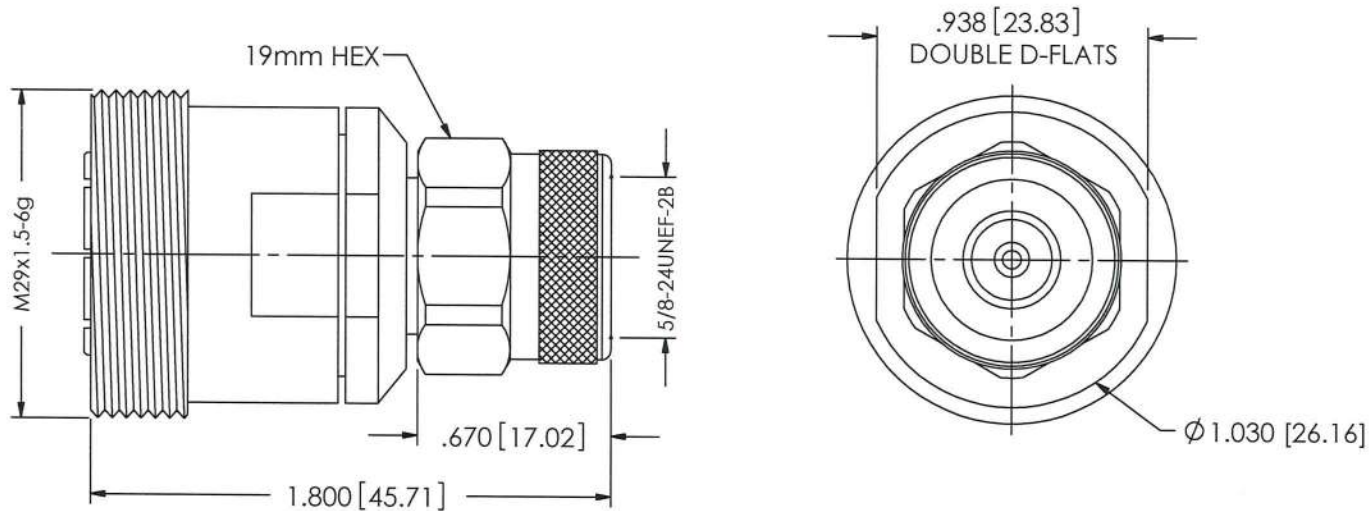

REV	DESCRIPTION	DATE	APPROVED
-	ENGINEERING RELEASE	10/10/10	JDMc
A	UPDATED DWG. FORMAT & SPECS	05/15/15	JDMc
B	UPDATED SPECS	10/21/21	JDMc

UNLESS OTHERWISE SPECIFIED
DIMENSIONS ARE IN INCHES
& [MILLIMETERS]

**RoHS
COMPLIANT**

PROPRIETARY

THE INFORMATION HEREIN IS CONFIDENTIAL AND PROPRIETARY. NO DISCLOSURE, REPRODUCTION, OR FURTHER DISSEMINATION MAY BE MADE WITHOUT THE EXPRESSED WRITTEN CONSENT OF RF INDUSTRIES.

DRAWN BY: C. ZUNIGA 10/21/21
 ENG APPROVAL: *[Signature]*
 ORJ. DRAWN: C. ZUNIGA 10/10/10

RFP² RF PRECISION PRODUCTS
A DIVISION OF RF INDUSTRIES

7610 MIRAMAR ROAD, SAN DIEGO, CA 92126-4202
(858) 549-6340 - FAX (858) 549-6345 - RFP2@RFINDUSTRIES.COM

TITLE:
**7/16 DIN JACK TO
N PLUG ADAPTER**

SIZE A	CODE 000000	DWG. NO. P2RFD-1672-SS	REV B
SHEET 1 OF 1			