

MicroTCA Board Layout and Routing Specifications

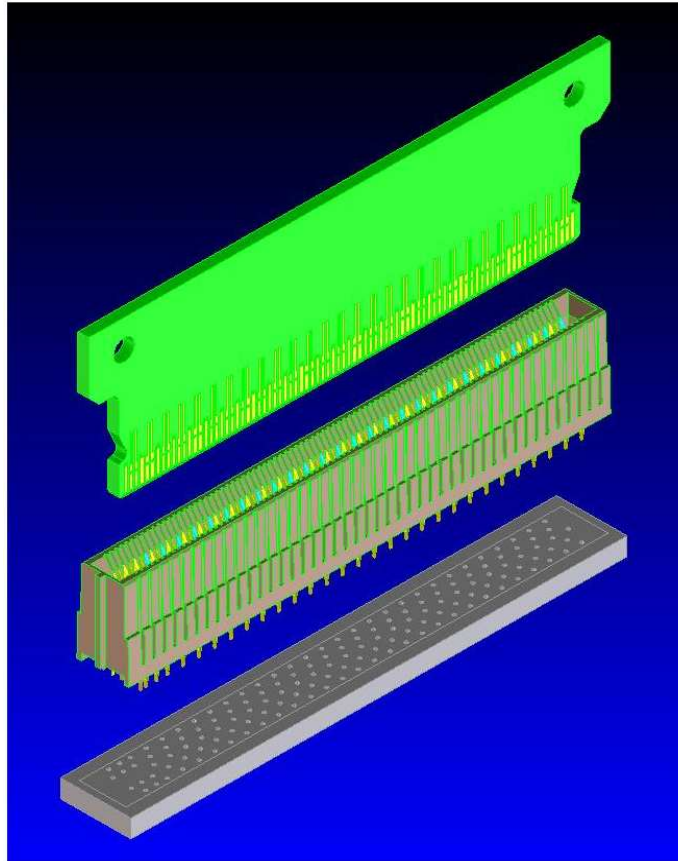

TABLE OF CONTENTS

1.0	– SCOPE	2
2.0	– CONNECTOR FOOTPRINT	3
3.0	– ROUTING	4
4.0	– STANDARD NOTES	5

REVISION: B	ECR/ECN INFORMATION: EC No: UCP2009-0441 DATE: 08/19/2008	TITLE: Board Layout and Routing For MicroTCA Connectors	SHEET No. 1 of 5
DOCUMENT NUMBER: AS-75594-100	CREATED / REVISED BY: Jason Squire	CHECKED BY: Dambach	APPROVED BY: Comerci

MicroTCA

Board Layout and Routing Specifications

1.0 SCOPE

The Board Layout and Routing Specification covers the Board layout and Routing used when determining the performance for the μ TCA printed circuit board (PCB) connector series. See 10 Gig Edge Connector SI Guideline (Document Number TS-75594) for test results.

Disclaimer:

Molex does not guarantee the performance of the final product to the information provided in this document. All information in this report is considered Molex proprietary and confidential. This guide is not intended as a substitute for engineering analysis

<u>REVISION:</u> B	<u>ECR/ECN INFORMATION:</u> EC No: UCP2009-0441 DATE: 08/19/2008	<u>TITLE:</u> Board Layout and Routing For MicroTCA Connectors	<u>SHEET No.</u> 2 of 5
<u>DOCUMENT NUMBER:</u> AS-75594-100	<u>CREATED / REVISED BY:</u> Jason Squire	<u>CHECKED BY:</u> Dambach	<u>APPROVED BY:</u> Comerci

MicroTCA Board Layout and Routing Specifications

2.0 CONNECTOR FOOTPRINT

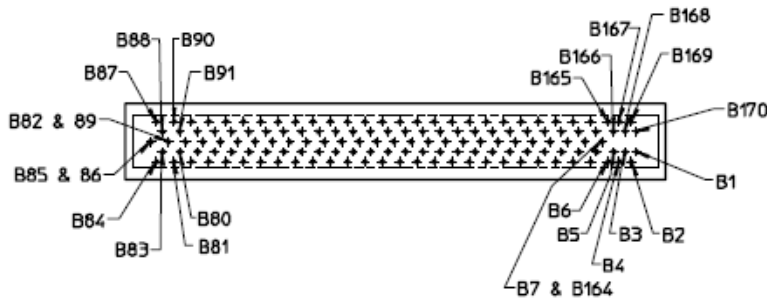
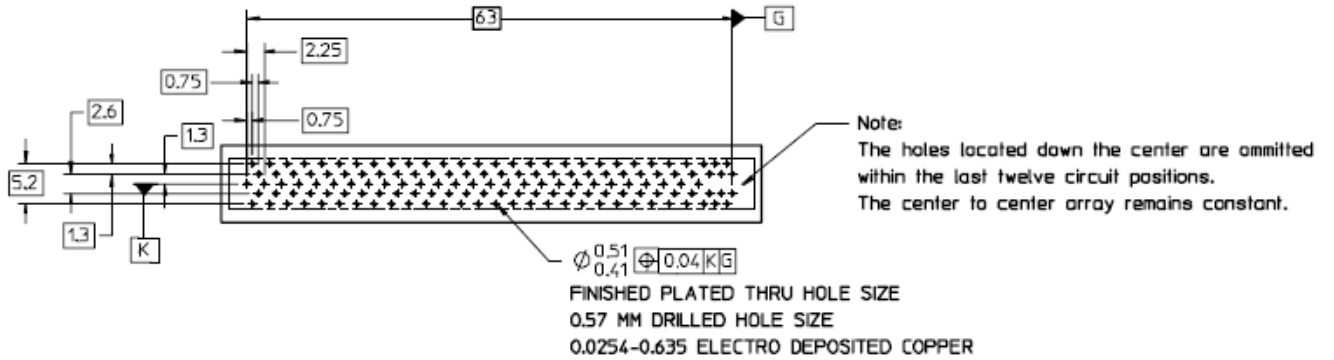

MOTHER BOARD HOLE LAYOUT

<u>REVISION:</u> B	<u>ECR/ECN INFORMATION:</u> EC No: UCP2009-0441 DATE: 08/19/2008	<u>TITLE:</u> Board Layout and Routing For MicroTCA Connectors	<u>SHEET No.</u> 3 of 5
<u>DOCUMENT NUMBER:</u> AS-75594-100		<u>CREATED / REVISED BY:</u> Jason Squire	<u>CHECKED BY:</u> Dambach
		<u>APPROVED BY:</u> Comerci	

MicroTCA Board Layout and Routing Specifications

3.0 ROUTING

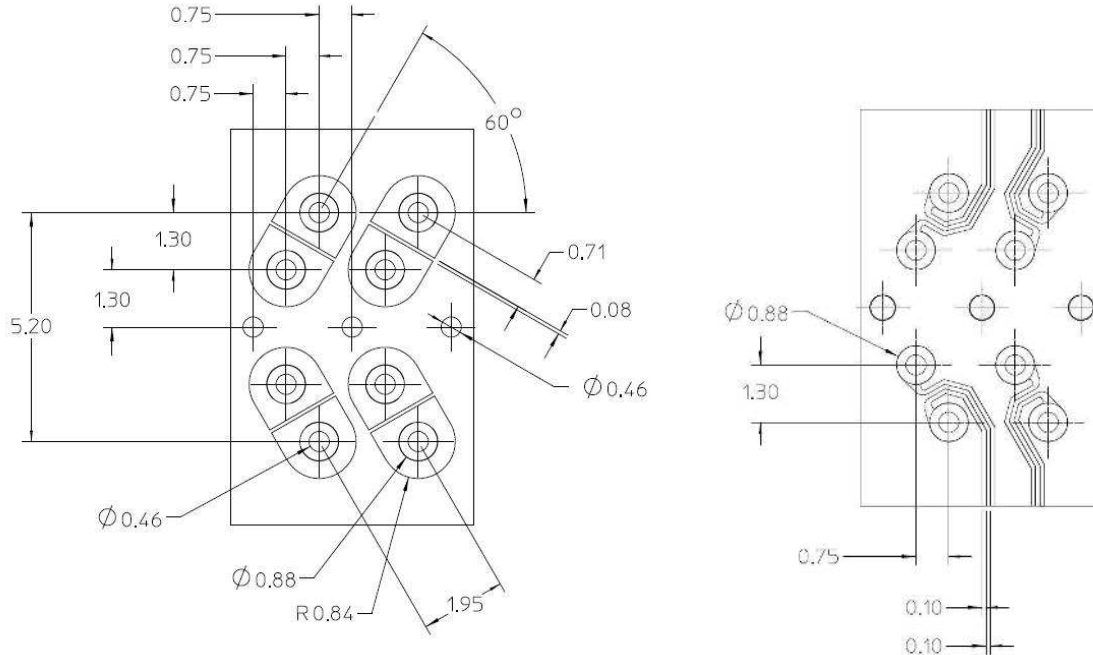
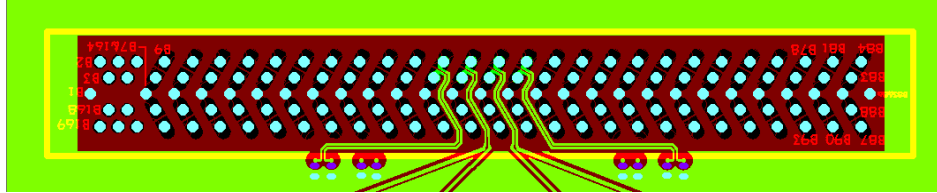

BOARD DESCRIPTION

Material:	Nelco 4000-13SI
Thickness	Board 2.8mm (0.11") host, 1.58mm (0.062) module Copper 1/2oz. (signal layers)
Number of layers	12 for the host board, 8 for the module board
Signal layers	3, 5, 8 & 10 (host board), 3 & 6 (module board)
Trace widths	7.5 mil uncoupled strip-lines 5.8 - 5.5 - 5.8 mil coupled strip-lines

The above board description is based on the PCB design for the μ -TCA electrical test board.

<u>REVISION:</u> B	<u>ECR/ECN INFORMATION:</u> EC No: UCP2009-0441 DATE: 08/19/2008	<u>TITLE:</u> Board Layout and Routing For MicroTCA Connectors	<u>SHEET No.</u> 4 of 5
<u>DOCUMENT NUMBER:</u> AS-75594-100	<u>CREATED / REVISED BY:</u> Jason Squire	<u>CHECKED BY:</u> Dambach	<u>APPROVED BY:</u> Comerci

MicroTCA

Board Layout and Routing Specifications

4.0 STANDARD NOTES

- 4.1 BOARD DIMENSIONS ARE IN MILLIMETERS UNLESS OTHERWISE NOTED.
- 4.2 DIMENSIONS TOLERANCE SHALL BE +/- 0.13MM UNLESS OTHERWISE NOTED.
- 4.3 SEE BOARD STACK-UP FOR LAYER DETAILS AND FINISHED COPPER WEIGHTS.
- 4.4 BOARD MATERIAL SHALL BE NELCO 4000-13SI
- 4.5 BOARD THICKNESS SHALL BE 0.110" (INCHES) THK. +/- 10%.
- 4.6 ALL TRACE WIDTHS ON ARTWORK ARE FINISHED WIDTHS.
- 4.7 ALL TRACES TOLERANCE SHALL BE +/- 10% FINISHED UNLESS OTHERWISE NOTED
- 4.8 ALL TRACES SHALL BE IMPEDANCE CONTROLLED. SINGLE ENDED TRACES SHALL BE CONTROLLED TO 50 OHMS +/- 10% FINISHED UNLESS OTHERWISE NOTED. DIFFERENTIAL TRACES SHALL BE CONTROLLED TO 100 PHMS +/- 10% FINISHED UNLESS OTHERWISE NOTED. CALCULATIONS ARE BASED ON Dk=3.25
- 4.9 SOLDERMASK SHALL BE LIQUID PHOTO IMAGEABLE (LPI) BOTH SIDES OVER BARE COPPER.
- 9.10 SHALL BE COVERED (NOT TINTED) UNLESS NOTED OTHERWISE.
- 9.11 SOLDERMASK TOLERANCE SHALL BE +/- 0.002" (INCHES).
- 9.12 THERE SHALL BE NO SOLDERMASK COVERING SURFACE MOUNT LANDS OR THRU HOLE PADS.
- 9.13 SOLDERMASK COLOR SHALL BE DARK GREEN.
- 9.14 HOLE LOCATION TOLERANCE SHALL BE +/- 0.02MM UNLESS OTHERWISE NOTED.
- 9.15 HOLE SIZES IN CHART ARE FINISHED HOLE SIZES.
- 9.16 SILKSCREEN COLOR SHALL BE WHITE.
- 9.17 CENTER PIN ON SMA CONNECTORS SHALL BE FILLED WITH DUPONT CB-100 OR EQUIV. SILVER EPOXY CONDUCTIVE FILL.
- 9.18 EXPOSED COPPER SHALL BE IMMERSION GOLD PLATED OVER MAXIMUM 100 MICROINCHES NICKEL
- 9.19 IF APPLICABLE, "X"-OUTS ARE NOT ACCEPTABLE

<u>REVISION:</u> B	<u>ECR/ECN INFORMATION:</u> EC No: UCP2009-0441 DATE: 08/19/2008	<u>TITLE:</u> Board Layout and Routing For MicroTCA Connectors	<u>SHEET No.</u> 5 of 5
<u>DOCUMENT NUMBER:</u> AS-75594-100		<u>CREATED / REVISED BY:</u> Jason Squire	<u>CHECKED BY:</u> Dambach
		<u>APPROVED BY:</u> Comerci	