

TMP112EVM Evaluation Board and Software Tutorial

This user's guide describes the characteristics, operation, and use of the TMP112EVM evaluation board. This guide discusses how to set up and configure the software and hardware and reviews various aspects of the program operation. Throughout this document, the terms *evaluation board*, *evaluation module*, and *EVM* are synonymous with the TMP112EVM. This user's guide also includes information regarding operating procedures and input/output connections, an electrical schematic, printed circuit board (PCB) layout drawings, and a parts list for the EVM.

Contents

1	Overview	2
2	TMP112EVM Hardware Setup	4
3	TMP112EVM Hardware	6
4	TMP112EVM Software	9
5	TMP112EVM Software Overview	11
6	TMP112 Documentation	18

List of Figures

1	Hardware Included with TMP112EVM Kit	3
2	TMP112EVM Hardware Setup	4
3	TMP112EVM Board Block Diagram	5
4	SM-USB-DIG Platform Block Diagram	6
5	Connecting SM-USB-DIG Platform	7
6	Confirmation of SM-USB-DIG Platform Driver Installation	7
7	10-Pin Ribbon Cable Extender	8
8	TMP112EVM Software Installation	9
9	TMP112EVM License Agreements	10
10	TMP112EVM Software Interface	11
11	TMP112EVM Software: Communication Error with the SM-USB-DIG Platform	11
12	TMP112 Reading from Registers	12
13	TMP112 Writing to Registers	13
14	Reading the Temperature Gauge	14
15	Configuring the Polarity	14
16	Active and Shutdown Mode	15
17	Extended and Normal Mode	15
18	Comparator and Interrupt Mode	15
19	Conversion Rate	16
20	Setting the Fault Queue	16
21	Setting the Path for the Log File	16
22	Alert Config Box	17
23	Register Tab	17
24	TMP112EVM Board Schematic	18
25	TMP112EVM PCB Top Layer (Component Side)	19
26	TMP112EVM PCB Bottom Layer	19

List of Tables

1	TMP112EVM Kit Contents.....	2
2	Related Documentation	4
3	Signal Definition of H1 on the TMP112EVM Board	5
4	Bill of Materials	20

1 Overview

The [TMP112](#) is a digital output temperature sensor capable of reading temperatures to 12 bits of resolution. The TMP112 uses a two-wire, I²C™ and SMBus™ interface that allows up to four devices on one bus. The TMP112 is ideal for extended temperature measurement, and is also specified to operate between –40°C and 125°C. The TMP112EVM is a platform for evaluating the performance of the TMP112 under various signal, reference, and supply conditions.

This document gives a general overview of the TMP112EVM and provides a general description of the features and functions to be considered while using this evaluation module.

1.1 TMP112EVM Kit Contents

[Table 1](#) summarizes the contents of the TMP112EVM kit. [Figure 1](#) illustrates all of the included hardware. Contact the [Texas Instruments Product Information Center](#) nearest you if any component is missing. TI highly recommends that you also check the [TMP112 product folder](#) on the TI web site at www.ti.com to verify that you have the latest versions of the related software.

Table 1. TMP112EVM Kit Contents

Item	Quantity
TMP112EVM PCB test board	1
SM-USB-DIG platform PCB	1
USB extender cable	1
10-pin connector ribbon cable	1

SMBus is a trademark of Intel Corporation.
 Microsoft, Windows are registered trademarks of Microsoft Corporation.
 I²C is a trademark of NXP Semiconductors.
 WinZIP is a registered trademark of WinZip International LLC.
 All other trademarks are the property of their respective owners.



Figure 1. Hardware Included with TMP112EVM Kit

1.2 Related Documentation from Texas Instruments

The following documents provide information regarding Texas Instruments' integrated circuits used in the assembly of the TMP112EVM. This user's guide is available from the TI web site under literature number **SBOU114**. Any letter appended to the literature number corresponds to the document revision that is current at the time of the writing of this document. Newer revisions may be available from www.ti.com, or call the Texas Instruments' Literature Response Center at (800) 477-8924 or the Product Information Center at (972) 644-5580. When ordering, identify the document by both title and literature number.

Table 2. Related Documentation

Document	Literature Number
TMP112 product data sheet	SBOS397
SM-USB-DIG platform user guide	SBOU098

2 TMP112EVM Hardware Setup

Figure 2 shows the overall system setup for the TMP112EVM. The computer runs software that communicates with the SM-USB-DIG platform. The SM-USB-DIG platform generates the digital signals used to communicate with the TMP112 test board. The SM-USB-DIG and TMP112EVM are easily connectable through a 10-pin, board-to-board connector attached to the SM-USB-DIG platform and the TMP112EVM PCBs. When these two boards are connected, simply plug the USB device from the SM-USB-DIG into the computer, as shown in Figure 2.

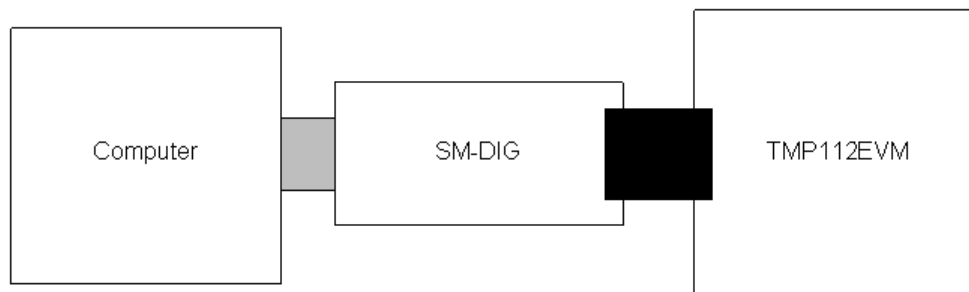

Figure 2. TMP112EVM Hardware Setup

2.1 Theory of Operation for TMP112 Hardware

The TMP112EVM only requires the two-wire I²C lines (SDA and SCLK) and V_{DUT}/GND to supply a constant 3.3 V and power return, as shown in Figure 3. The TMP112EVM also has test points to monitor these signal lines and ground, in case users may want to use their own signals or verify successful I²C communications.

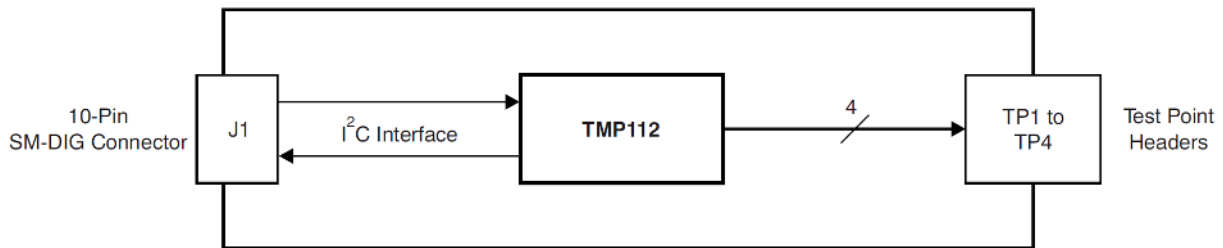

Figure 3. TMP112EVM Board Block Diagram

2.2 Signal Definitions of H1 (10-Pin Male Connector Socket)

Table 3 shows the pin out for the 10-pin connector socket used to communicate between the TMP112EVM and the SM-USB-DIG. Note that the TMP112EVM uses only the necessary I²C communication lines (pins 1 and 3) and the V_{DUT} and GND (pins 6 and 8, respectively) to issue commands to the TMP112 sensors.

Table 3. Signal Definition of H1 on the TMP112EVM Board

Pin on U1	Signal	Description
1	I2C_SCL	I ² C clock signal (SCL)
2	CTRL/MEAS4	GPIO: control output or measure input
3	I2C_SDA1	I ² C data signal (SDA)
4	CTRL/MEAS5	GPIO: control output or measure input
5	SPI_DOUT1	SPI data output (MOSI)
6	V _{DUT}	Switchable DUT power supply: 3.3 V, 5 V, Hi-Z (disconnected) ⁽¹⁾
7	SPI_CLK	SPI clock signal (SCLK)
8	GND	Power Return (GND)
9	SPI_CS1	SPI chip-select signal (CS)
10	SPI_DIN1	SPI data input (MISO)

⁽¹⁾ When V_{DUT} is Hi-Z, all digital I/O are Hi-Z as well.

2.2.1 Theory of Operation for SM-USB-DIG Platform

Figure 4 shows the block diagram for the SM-USB-DIG platform. This platform is a general-purpose data acquisition system that is used on several different Texas Instruments evaluation modules. The details of its operation are included in a separate document, [SBOU098](#) (available for download at [www.ti.com](#)). The block diagram shown in Figure 4 gives a brief overview of the platform. The primary control device on the SM-USB-DIG platform is the [TUSB3210](#).

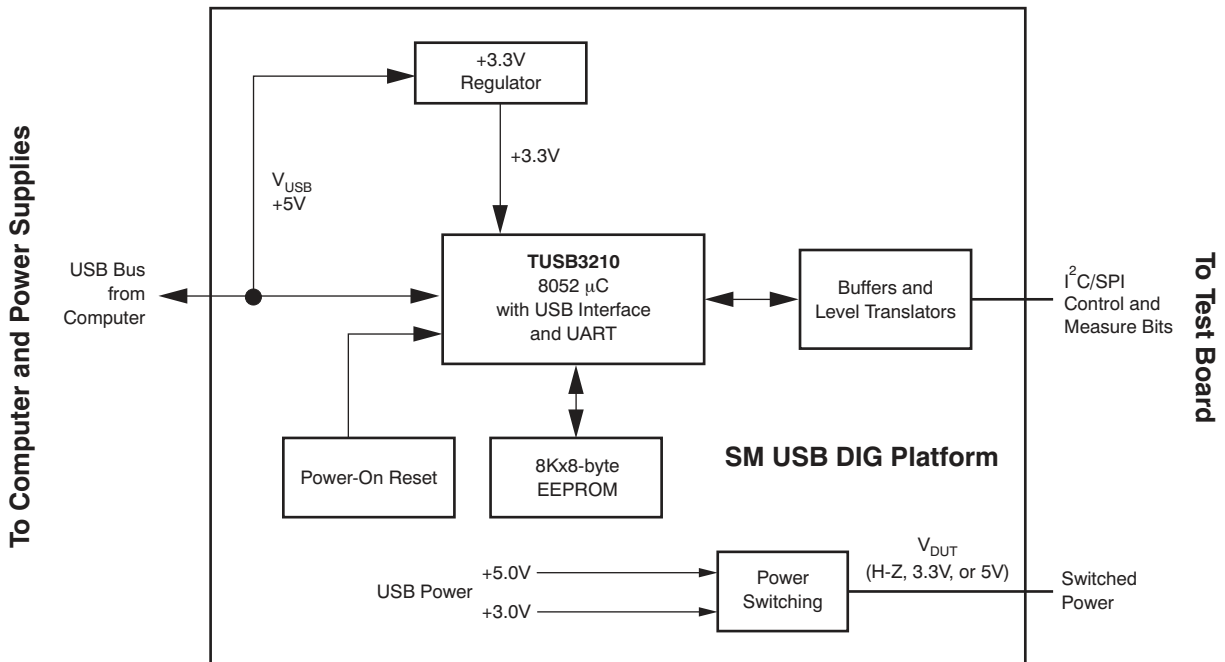

Figure 4. SM-USB-DIG Platform Block Diagram

3 TMP112EVM Hardware

The TMP112EVM hardware overview involves connecting the two PCBs of the EVM together, connecting the USB cable, applying power, and setting the jumpers. This section presents the details of this procedure.

3.1 Electrostatic Discharge Warning

CAUTION

Many of the components on the TMP112EVM are susceptible to damage by electrostatic discharge (ESD). Customers are advised to observe proper ESD handling precautions when unpacking and handling the EVM, including the use of a grounded wrist strap at an approved ESD workstation.

3.2 Typical Hardware Connections

To connect the TMP112 test board and the SM-USB-DIG platform together, gently slide the male and female ends of the 10-pin connectors together. Make sure that the two connectors are completely pushed together; loose connections may cause intermittent operation.

3.3 Connecting the USB Cable to the DIG

Figure 5 shows the typical response to connecting the SM-USB-DIG platform board to a computer USB port for the first time. Typically, the computer responds with a *Found New Hardware, USB Device* pop-up dialog. The pop-up window then changes to *Found New Hardware, USB Human Interface Device*. This pop-up indicates that the device is ready to be used. The SM-USB-DIG platform uses the human interface device drivers that are part of the Microsoft® Windows® operating system.



Figure 5. Connecting SM-USB-DIG Platform

In some cases, the Windows *Add Hardware Wizard* appears. If this prompt pops up, allow the system device manager to install the human interface drivers by clicking **Yes** when requested to install drivers. Windows confirms installation of the drivers with the message shown in Figure 6.

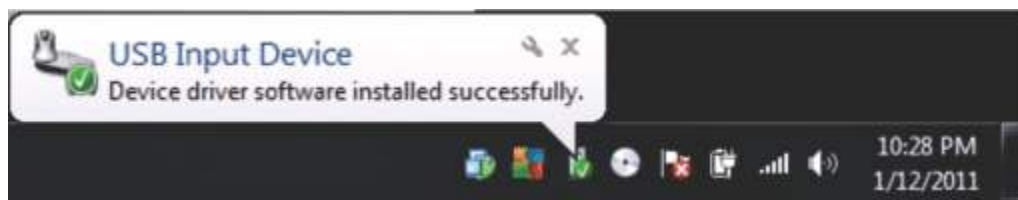

Figure 6. Confirmation of SM-USB-DIG Platform Driver Installation

3.4 TMP112EVM Features

This section describes some of the hardware features present on the TMP112EVM test board.

3.4.1 I²C Test Points

I²C test points are included on the TMP112 test board for user convenience. These test points can be used to monitor the two-wire lines of the I²C interface or to run the TMP112 test board externally without the use of the SM-USB-DIG.

3.4.2 10-Pin Connector Ribbon Extender (Optional)

The TMP112EVM kit ships with an optional ribbon cable for extending the connection between the SM-USB-DIG and the PCB. This extension cable can be useful if high temperature tests must be run on the test board because the SM-USB-DIG is not rated for high temperatures. To connect the ribbon cable, attach the cable to the EVM and SM-USB-DIG as shown in [Figure 7](#).



Figure 7. 10-Pin Ribbon Cable Extender

4 TMP112EVM Software

This section discusses how to install the TMP112EVM software.

4.1 Hardware Requirements

The TMP112EVM software is tested on Microsoft Windows XP and 7 operating systems (OS) with United States and European regional settings. The software also functions on other Windows OS platforms.

4.2 Software Installation

The TMP112EVM software is available through the [TMP112EVM product folder](#) on the TI web site. To install the software to a computer, locate the compressed file (*TMP112EVM.zip*) and open it using WinZIP® or a similar file compression program; extract the TMP112EVM files into a specific TMP112EVM folder (for example, *C:\TMP112EVM*) on your hard drive.

When the files are extracted, navigate to the TMP112EVM folder you created on the hard drive. Locate the *setup.exe* file and execute it to start the installation. The TMP112 software installer file then begins the installation process, as shown in [Figure 8](#).

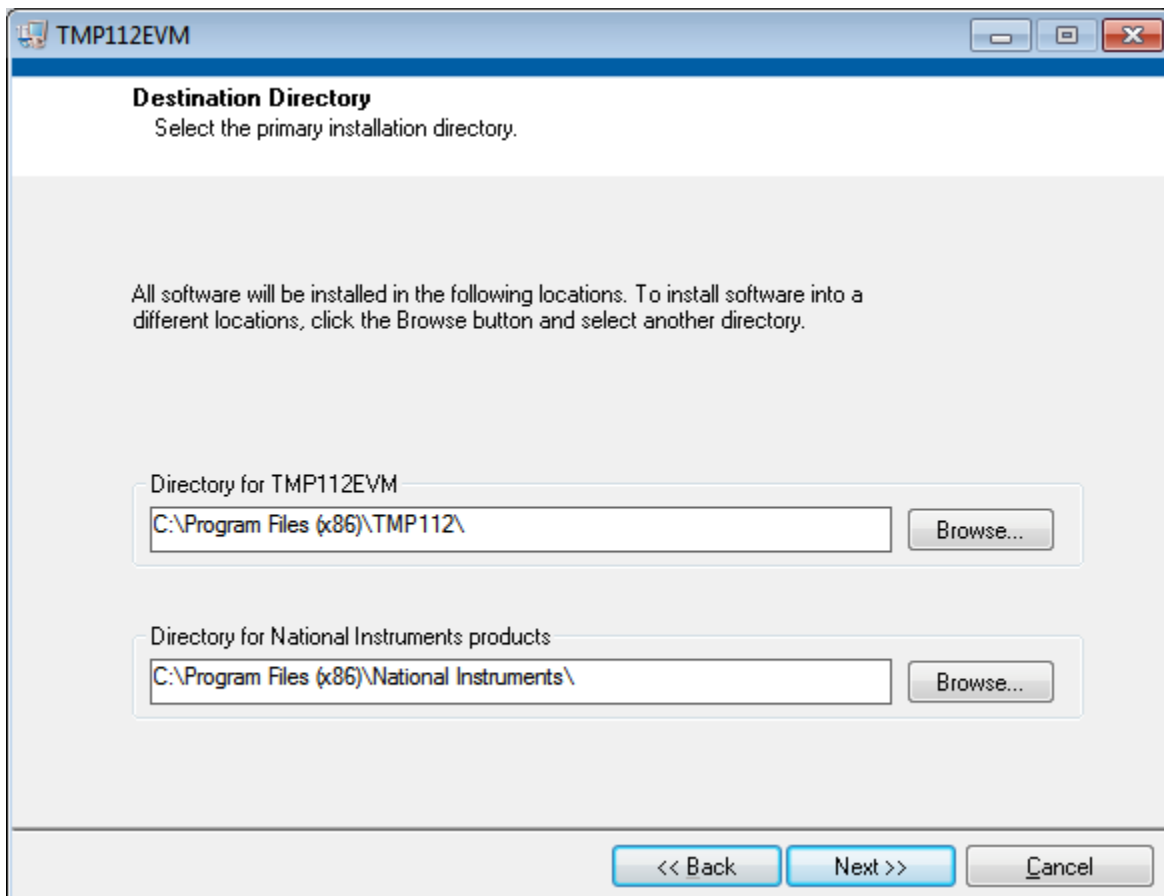

Figure 8. TMP112EVM Software Installation

After the installation process initializes, the user is given the choice of selecting the directory in which to install the program; the default location is *C:\Program Files\TMP112* and *C:\Program Files\National Instruments*. Following this option, two license agreements are presented that must be accepted, as shown in [Figure 9](#). After accepting the Texas Instruments and National Instruments license agreements, the progress bar opens and shows the installation of the software. When the installation process is completed, click **Finish**.

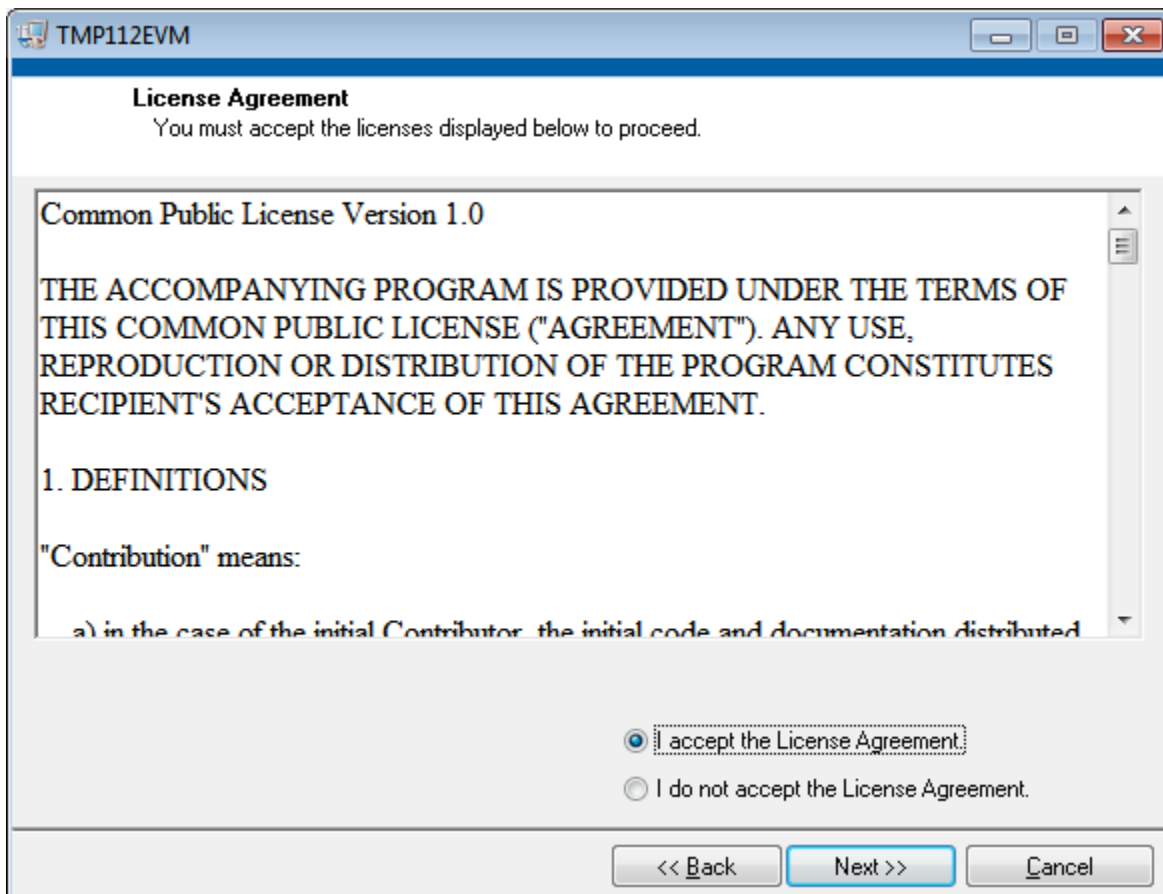

Figure 9. TMP112EVM License Agreements

5 TMP112EVM Software Overview

This section discusses how to use the TMP112EVM software.

5.1 Starting the TMP112EVM Software

The TMP112 software can be operated through the Windows *Start* menu. From *Start*, select *All Programs*; then select the *TMP112EVM* program.

Figure 10 shows how the software appears if the TMP112EVM is functioning properly.

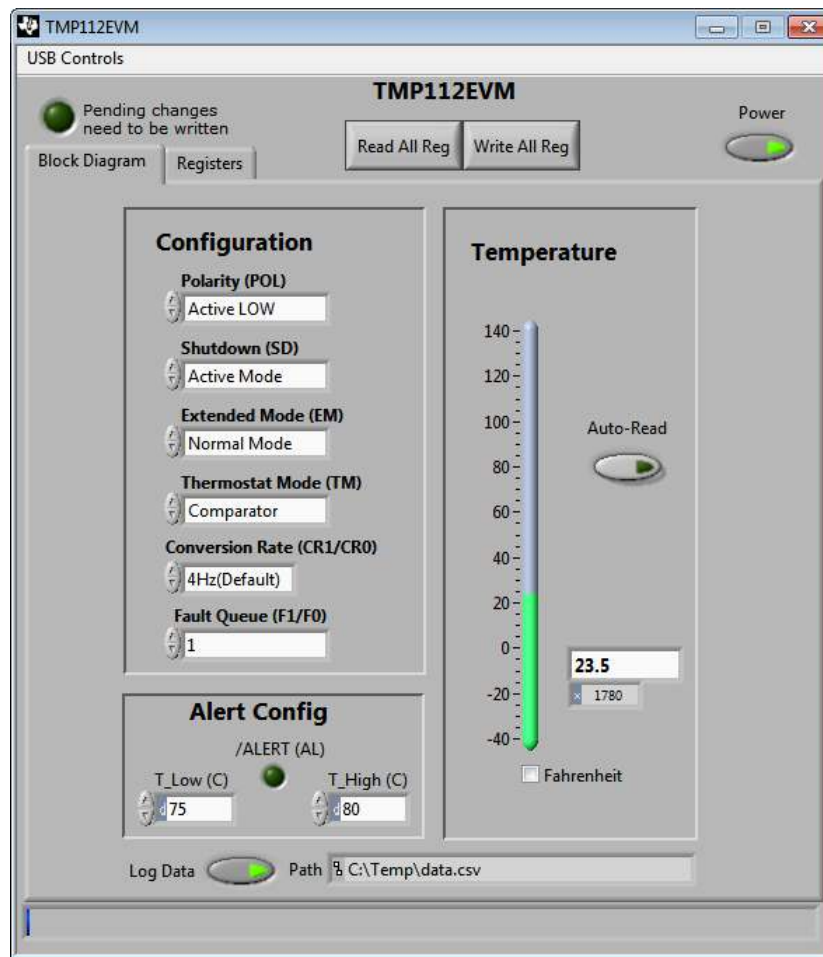

Figure 10. TMP112EVM Software Interface

Figure 11 shows an error message that is displayed if the computer cannot communicate with the SM-USB-DIG platform. If you receive this error message, first check that the USB extension cable is properly connected to both the computer USB port and to the SM-USB-DIG platform. Another possible source for this error is a problem with the computer USB human interface device driver. Make sure that the device is recognized when the USB cable is plugged in; recognition is indicated by a Windows-generated confirmation sound.

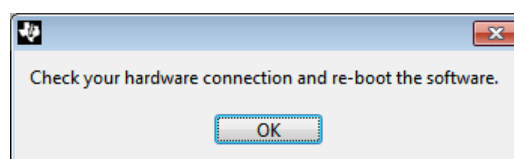

Figure 11. TMP112EVM Software: Communication Error with the SM-USB-DIG Platform

5.2 Using the TMP112Software

5.2.1 Reading from Registers

When first starting the TMP112EVM software, the user must confirm stable connections to the test board by toggling the **Read All Reg** button (shown in Figure 12). If all devices are communicating correctly, the user then sees the temperature change over time in the TMP112 *Temperature* box. By toggling the **Auto-Read** button, the temperature is automatically refreshed at the rate specified in the *Conversion Rate* pull-down menu. The conversion rate can only be changed when **Auto-Read** is turned off.

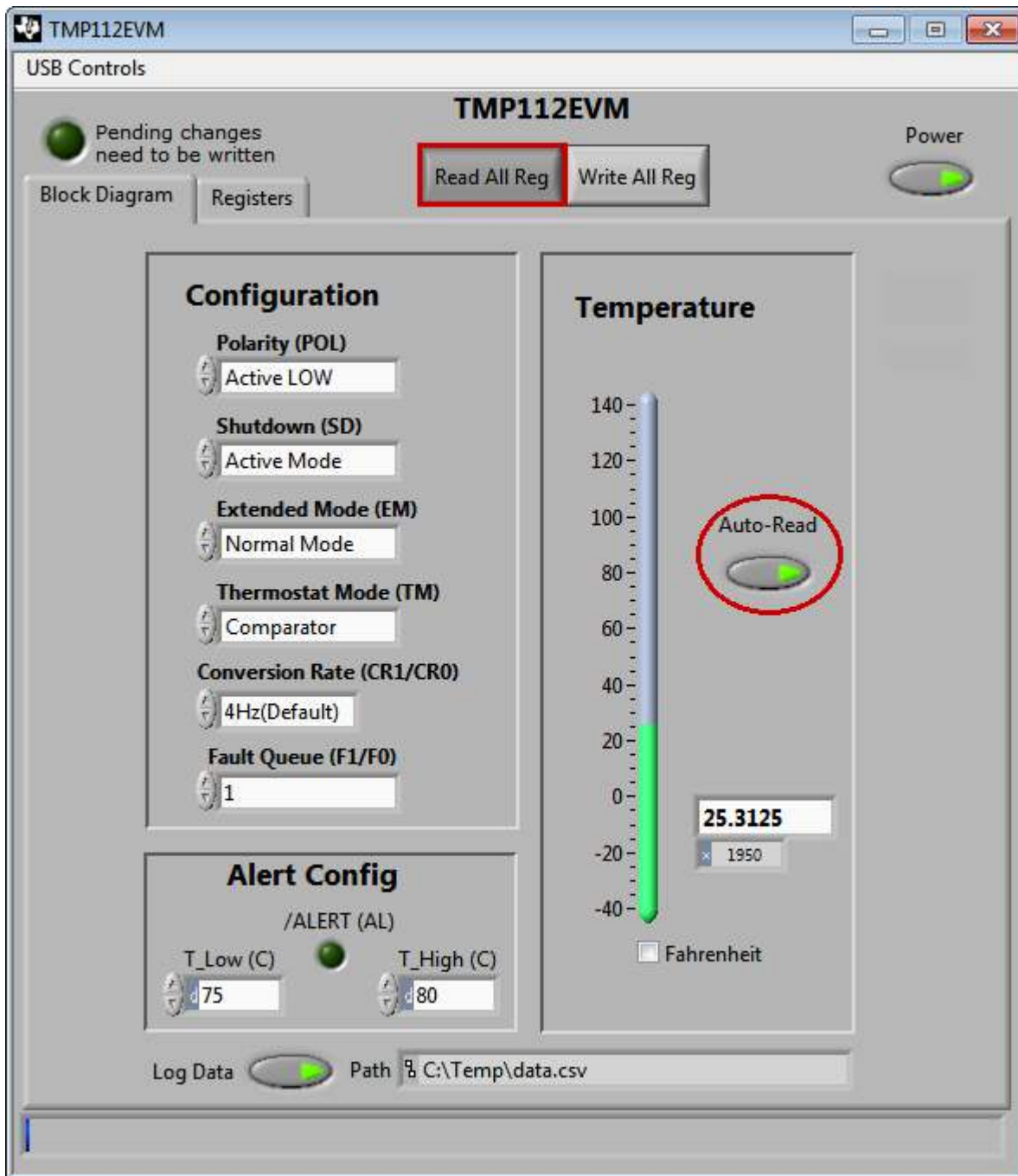

Figure 12. TMP112 Reading from Registers

5.2.2 Writing to Registers

The TMP112EVM software contains two different methods for writing data: *Write All Reg* and *Auto-Write Reg*. Writing the registers individually without auto-write can be useful when adjusting large numbers of the configuration registers on the left side of the panel. The auto-write feature automatically makes changes to the configuration register whenever one of the configuration settings on the left changes, as shown in [Figure 13](#).

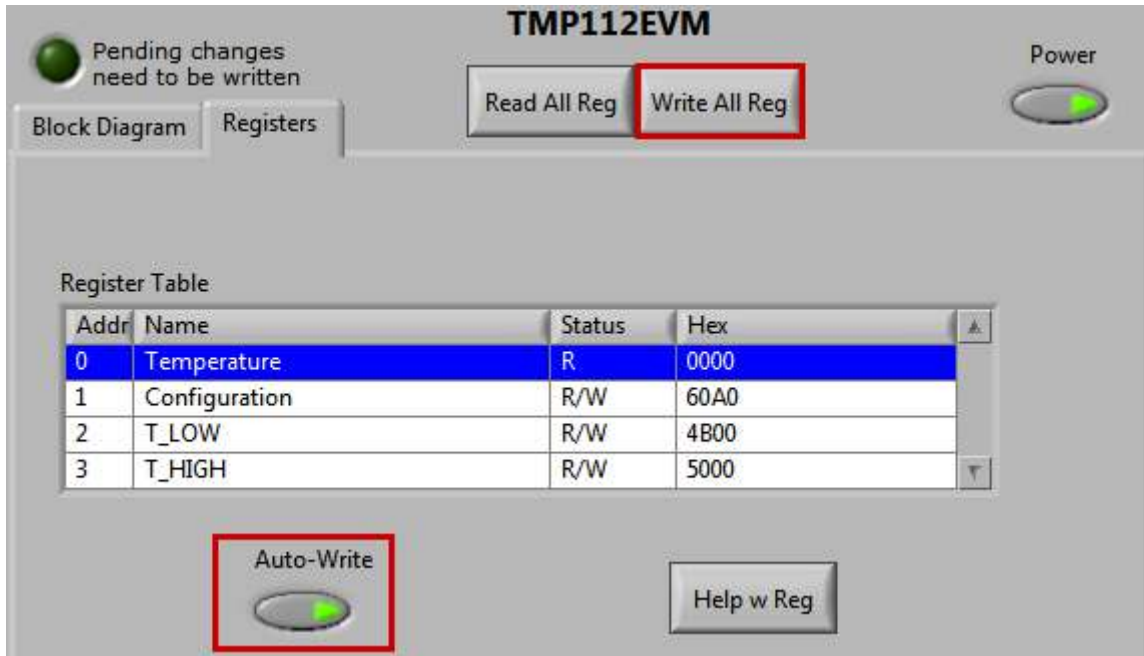

Figure 13. TMP112 Writing to Registers

5.2.3 Reading the Temperature Gauge

The *Temperature* box on the TMP112EVM software window displays the measured values of the TMP112 registers in a graphical format, as [Figure 14](#) shows. This value can be toggled to either (degrees) Fahrenheit or Celsius by toggling the checkbox at the bottom of the window. Note that changing to extended mode on the TMP112EVM software also changes the full-scale value of the TMP112 thermometer.

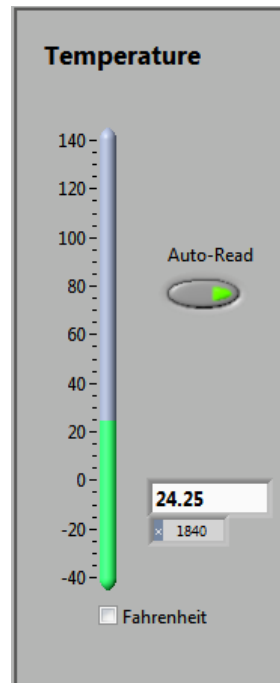

Figure 14. Reading the Temperature Gauge

5.2.4 Polarity (Alert Pin)

The polarity drop-down selection box in the *Configuration* section allows the user to toggle how the Alert pin behaves when triggered. When the polarity box is set to active low, as shown in [Figure 15](#), the LED on the TMP112EVM board lights up when triggered and functions as a ground source. When the polarity box is set to active high, the LED on the TMP112EVM board does not function, and the Alert pin on the TMP112 is set to DVDD when triggered.

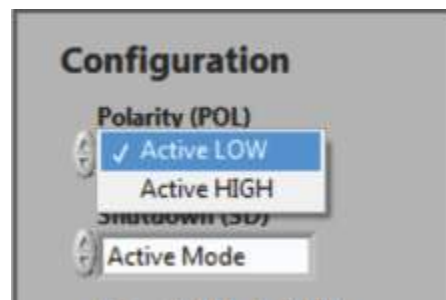

Figure 15. Configuring the Polarity

5.2.5 Shutdown Mode

The TMP112 has a built-in shutdown mode that allows the device to stop consuming power. The shutdown mode selection box (shown in Figure 16) can also be used to clear the Alert pin when the interrupt mode (refer to Section 5.2.7) is selected. Note that the TMP112EVM cannot perform temperature conversions while in shutdown mode.

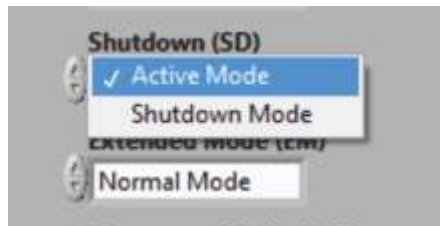

Figure 16. Active and Shutdown Mode

5.2.6 Extended Mode

The TMP112EVM has two modes for storing converted temperature data (extended mode and normal mode), as shown in Figure 17. Normal mode provides the temperature, T_{LOW} , and T_{HIGH} registers 12 bits of accuracy. By changing to extended mode, the user increases to 13 bits of accuracy and adjusts the full-scale value of the three registers from 120°C to 150°C. Note that adding an additional bit of accuracy also changes the current T_{HIGH} and T_{LOW} values; these values must then be reset to the user's original, intended values after adjusting the extended mode drop-down box.

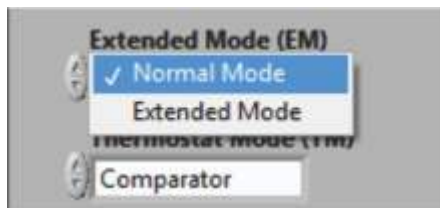

Figure 17. Extended and Normal Mode

5.2.7 Thermostat Mode

Thermostat mode, in the *Configuration* box, allows the user to designate how the TMP112 Alert pin behaves when the temperature register exceeds the T_{HIGH} register. When the TMP112EVM software is in comparator mode, the Alert pin triggers if the temperature measured by the TMP112 exceeds the T_{HIGH} register for the set amount of faults, as described in the Fault Queue (see Section 5.2.9). When the Alert pin is triggered, it remains triggered until the temperature measured by the TMP112 falls below the T_{LOW} register value for the set amount of faults.

When the TMP112EVM software is in interrupt mode, the Alert pin does not automatically clear after falling below the T_{LOW} register limit. Instead, the user must either select the **Read All Reg** button or put the device into shutdown mode, as described in Section 5.2.5. After the **Read All Reg** button is selected, or after the device is put into shutdown mode, the Alert pin clears when the measured temperature drops down below the T_{LOW} register. Figure 18 shows the thermostat mode dialog.

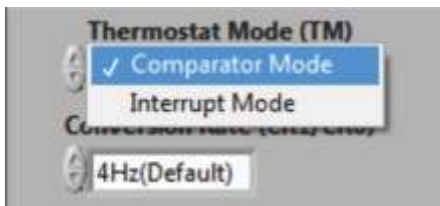

Figure 18. Comparator and Interrupt Mode

5.2.8 Conversion Rate

The *Conversion Rate* selection box (shown in [Figure 19](#)) allows the user to change how long each temperature conversion takes the TMP112 to perform. The user may want to select a slower conversion time, as shown in [Figure 19](#), to make the TMP112 consume less power.

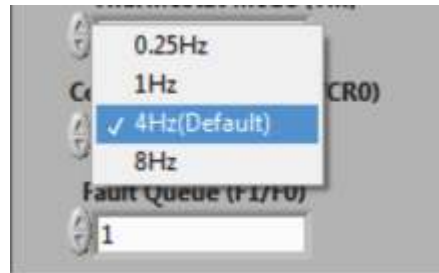

Figure 19. Conversion Rate

5.2.9 Fault Queue

The fault queue drop-down box allows the user to configure how many faults must be triggered before the Alert pin is activated, as shown in [Figure 20](#). A fault is generated whenever the TMP112 T_{HIGH} register is exceeded by the temperature register. This feature can be useful to prevent the TMP112 from triggering on temperature spikes that the user may not want to trigger with the Alert pin.

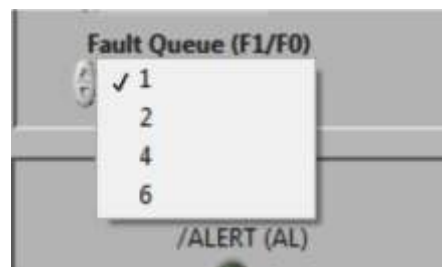

Figure 20. Setting the Fault Queue

5.2.10 Logging

Specify the path and filename for logging data, as shown in [Figure 21](#). The standard file format is .csv. Data are saved in four columns: Time, Temp, Tlow and Thigh. Time is in the format of hh:mm:ss.ms; the remaining columns are readouts from the TMP112 in Celsius.

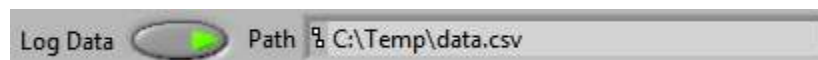

Figure 21. Setting the Path for the Log File

5.2.11 Alert Configuration (T_{LOW} and T_{HIGH})

The *Alert Config* box has three objects that make up the main functionality of the TMP112 Alert pin (the Alert bit, T_{LOW} register, and T_{HIGH} register), as [Figure 22](#) shows. The green LED within the *Alert Config* box lights up when the T_{HIGH} register is exceeded and the Alert pin is activated. This LED is denoted as an *Alert* because of the default configuration. The Alert pin can also be switched to an active high, as shown in [Section 5.2.4](#), if so desired by the user.



Figure 22. Alert Config Box

The T_{LOW} input box allows the user to set when the alert pin is cleared. When the measured value in the temperature register falls below the T_{LOW} threshold, the Alert pin clears, depending on which thermostat mode is selected. For more information on the behavior of the thermostat mode, see [Section 5.2.7](#).

The T_{HIGH} input box allows the user to set when the Alert pin is triggered. When the measured value in the temperature register exceeds the T_{HIGH} threshold, the Alert pin triggers until the temperature returns to a value below the T_{LOW} threshold, depending on the thermostat mode selected.

5.2.12 Registers Tab

The registers tab displays the individual register setting for the TMP112 sensors. For more information on the individual registers and the bit meanings, simply highlight the desired register and hit the **Help with Reg** button shown in [Figure 23](#).

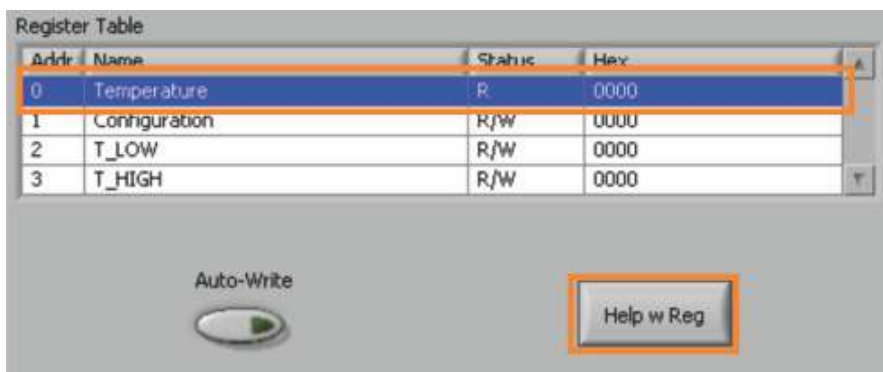

Figure 23. Register Tab

The Registers tab also includes the Dig_Bits table. The Dig_Bits table allows the user to monitor and change individual bits by highlighting the desired register and toggling the bit controls beneath it.

NOTE: Only the bits that can be written within a given register can be toggled.

6 TMP112 Documentation

This section contains the complete bill of materials and PCB layout for the TMP112EVM.

NOTE: These board layouts are not to scale. These image are intended to show how the board is laid out and are not intended to be used for manufacturing TMP112EVM PCBs.

6.1 TMP112EVM Board Schematic

Figure 24 shows the schematic for the TMP112EVM board.

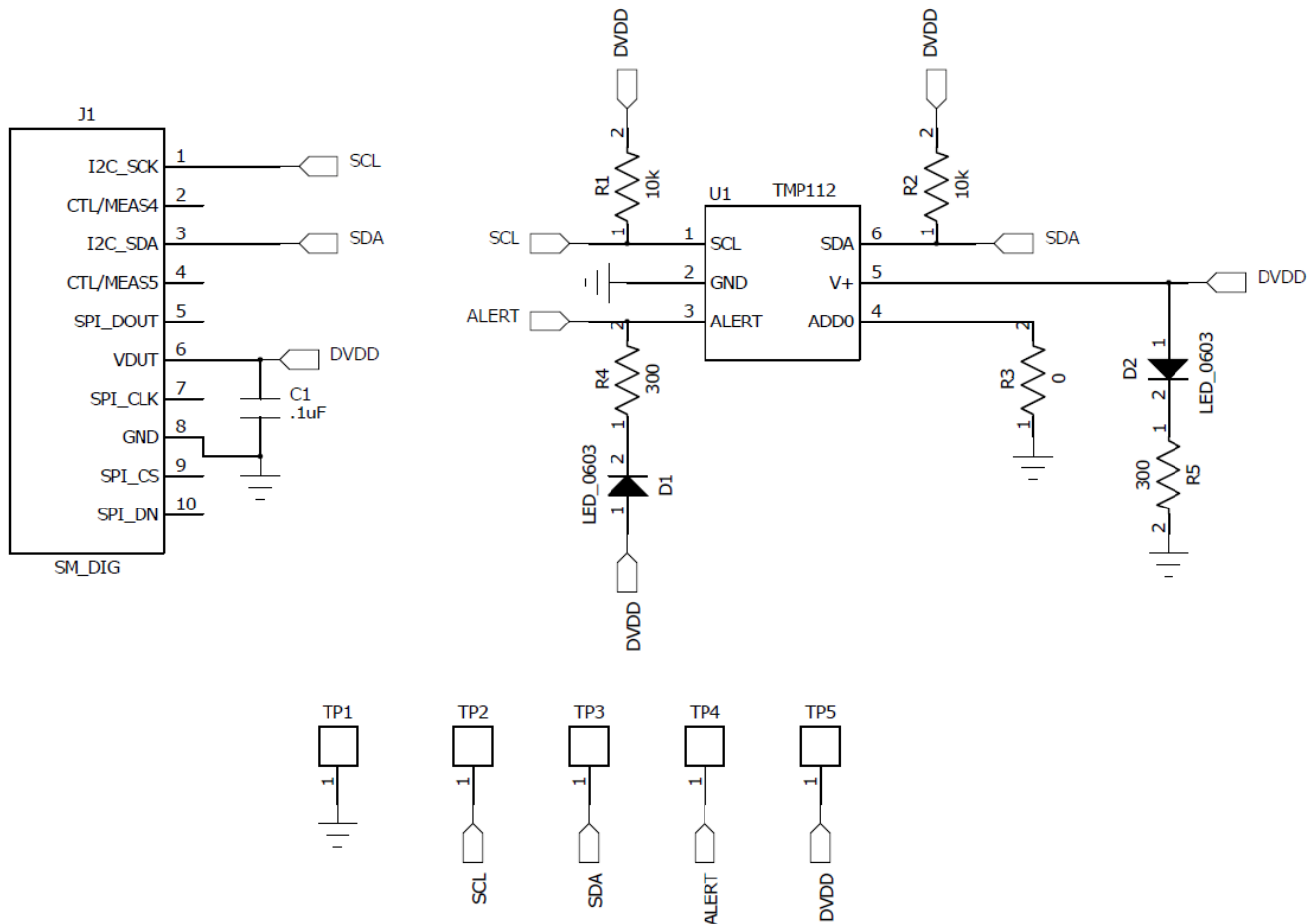

Figure 24. TMP112EVM Board Schematic

6.2 PCB Layout

Figure 25 and Figure 26 show the PCB layout of the TMP112EVM.

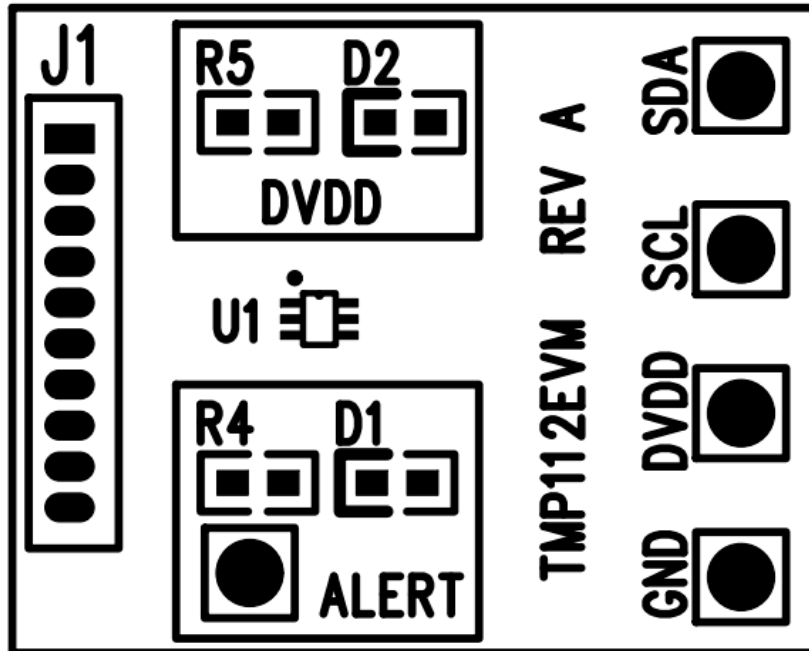

Figure 25. TMP112EVM PCB Top Layer (Component Side)

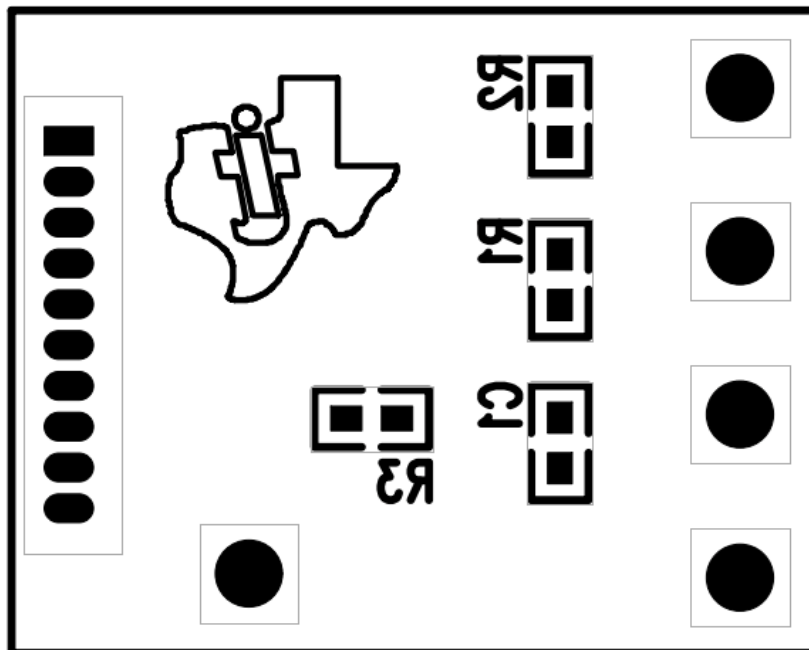

Figure 26. TMP112EVM PCB Bottom Layer

6.3 Bill of Materials

Table 4 lists the bill of materials for the TMP112EVM.

Table 4. Bill of Materials

Item No.	Qty	Value	Ref Des	Description	Vendor/Mfr	Part Number
1	2	10 k Ω	R1, R2	Resistor, 10 k Ω 1/10W 5% 0603 SMD	Stackpole Electronics	RMCF0603JT10K0
2	1	300 Ω	R4, R5	Resistor, 300 Ω 1/10W 5% 0603 SMD	Panasonic	ERJ-3GEYJ301V
3	1	0 Ω	R3	Resistor, 0.0 Ω 1/10W 0603 SMD	Stackpole Electronics	RMCF0603ZT0R00
4	1	0.1 μ F	C1	Capacitor, Ceramic, 0.10- μ F 25-V Y5V 0603	TDK Corporation	C1608Y5V1E104Z
5	2	2 V, 5 mA	D1, D2	LED Green Wide Angle 0603 SMD	Lite-On Inc	LTST-C193KGKT-5A
6	1	—	U1	TMP112	Texas Instruments	
7	1	Jumper TP cut to size (See Note 3xx)	Jumpers, All	Connector, Header 50-Pos .100-in. SGL Gold	Samtec	TSW-150-07-G-S
8	1	Super MiniDIG connector Socket (See Note 2xx)	J1	Connector, Socket 50-Pin .050 R/A Sngl	Mill-Max Manufacturing	851-43-050-20- 001000

ADDITIONAL TERMS AND CONDITIONS, WARNINGS, RESTRICTIONS, AND DISCLAIMERS FOR EVALUATION MODULES

Texas Instruments Incorporated (TI) markets, sells, and loans all evaluation boards, kits, and/or modules (EVMs) pursuant to, and user expressly acknowledges, represents, and agrees, and takes sole responsibility and risk with respect to, the following:

1. User agrees and acknowledges that EVMs are intended to be handled and used for feasibility evaluation only in laboratory and/or development environments. Notwithstanding the foregoing, in certain instances, TI makes certain EVMs available to users that do not handle and use EVMs solely for feasibility evaluation only in laboratory and/or development environments, but may use EVMs in a hobbyist environment. All EVMs made available to hobbyist users are FCC certified, as applicable. Hobbyist users acknowledge, agree, and shall comply with all applicable terms, conditions, warnings, and restrictions in this document and are subject to the disclaimer and indemnity provisions included in this document.
2. Unless otherwise indicated, EVMs are not finished products and not intended for consumer use. EVMs are intended solely for use by technically qualified electronics experts who are familiar with the dangers and application risks associated with handling electrical mechanical components, systems, and subsystems.
3. User agrees that EVMs shall not be used as, or incorporated into, all or any part of a finished product.
4. User agrees and acknowledges that certain EVMs may not be designed or manufactured by TI.
5. User must read the user's guide and all other documentation accompanying EVMs, including without limitation any warning or restriction notices, prior to handling and/or using EVMs. Such notices contain important safety information related to, for example, temperatures and voltages. For additional information on TI's environmental and/or safety programs, please visit www.ti.com/esh or contact TI.
6. User assumes all responsibility, obligation, and any corresponding liability for proper and safe handling and use of EVMs.
7. Should any EVM not meet the specifications indicated in the user's guide or other documentation accompanying such EVM, the EVM may be returned to TI within 30 days from the date of delivery for a full refund. THE FOREGOING LIMITED WARRANTY IS THE EXCLUSIVE WARRANTY MADE BY TI TO USER AND IS IN LIEU OF ALL OTHER WARRANTIES, EXPRESSED, IMPLIED, OR STATUTORY, INCLUDING ANY WARRANTY OF MERCHANTABILITY OR FITNESS FOR ANY PARTICULAR PURPOSE. TI SHALL NOT BE LIABLE TO USER FOR ANY INDIRECT, SPECIAL, INCIDENTAL, OR CONSEQUENTIAL DAMAGES RELATED TO THE HANDLING OR USE OF ANY EVM.
8. No license is granted under any patent right or other intellectual property right of TI covering or relating to any machine, process, or combination in which EVMs might be or are used. TI currently deals with a variety of customers, and therefore TI's arrangement with the user is not exclusive. TI assumes no liability for applications assistance, customer product design, software performance, or infringement of patents or services with respect to the handling or use of EVMs.
9. User assumes sole responsibility to determine whether EVMs may be subject to any applicable federal, state, or local laws and regulatory requirements (including but not limited to U.S. Food and Drug Administration regulations, if applicable) related to its handling and use of EVMs and, if applicable, compliance in all respects with such laws and regulations.
10. User has sole responsibility to ensure the safety of any activities to be conducted by it and its employees, affiliates, contractors or designees, with respect to handling and using EVMs. Further, user is responsible to ensure that any interfaces (electronic and/or mechanical) between EVMs and any human body are designed with suitable isolation and means to safely limit accessible leakage currents to minimize the risk of electrical shock hazard.
11. User shall employ reasonable safeguards to ensure that user's use of EVMs will not result in any property damage, injury or death, even if EVMs should fail to perform as described or expected.
12. User shall be solely responsible for proper disposal and recycling of EVMs consistent with all applicable federal, state, and local requirements.

Certain Instructions. User shall operate EVMs within TI's recommended specifications and environmental considerations per the user's guide, accompanying documentation, and any other applicable requirements. Exceeding the specified ratings (including but not limited to input and output voltage, current, power, and environmental ranges) for EVMs may cause property damage, personal injury or death. If there are questions concerning these ratings, user should contact a TI field representative prior to connecting interface electronics including input power and intended loads. Any loads applied outside of the specified output range may result in unintended and/or inaccurate operation and/or possible permanent damage to the EVM and/or interface electronics. Please consult the applicable EVM user's guide prior to connecting any load to the EVM output. If there is uncertainty as to the load specification, please contact a TI field representative. During normal operation, some circuit components may have case temperatures greater than 60°C as long as the input and output are maintained at a normal ambient operating temperature. These components include but are not limited to linear regulators, switching transistors, pass transistors, and current sense resistors which can be identified using EVMs' schematics located in the applicable EVM user's guide. When placing measurement probes near EVMs during normal operation, please be aware that EVMs may become very warm. As with all electronic evaluation tools, only qualified personnel knowledgeable in electronic measurement and diagnostics normally found in development environments should use EVMs.

Agreement to Defend, Indemnify and Hold Harmless. User agrees to defend, indemnify, and hold TI, its directors, officers, employees, agents, representatives, affiliates, licensors and their representatives harmless from and against any and all claims, damages, losses, expenses, costs and liabilities (collectively, "Claims") arising out of, or in connection with, any handling and/or use of EVMs. User's indemnity shall apply whether Claims arise under law of tort or contract or any other legal theory, and even if EVMs fail to perform as described or expected.

Safety-Critical or Life-Critical Applications. If user intends to use EVMs in evaluations of safety critical applications (such as life support), and a failure of a TI product considered for purchase by user for use in user's product would reasonably be expected to cause severe personal injury or death such as devices which are classified as FDA Class III or similar classification, then user must specifically notify TI of such intent and enter into a separate Assurance and Indemnity Agreement.

RADIO FREQUENCY REGULATORY COMPLIANCE INFORMATION FOR EVALUATION MODULES

Texas Instruments Incorporated (TI) evaluation boards, kits, and/or modules (EVMs) and/or accompanying hardware that is marketed, sold, or loaned to users may or may not be subject to radio frequency regulations in specific countries.

General Statement for EVMs Not Including a Radio

For EVMs not including a radio and not subject to the U.S. Federal Communications Commission (FCC) or Industry Canada (IC) regulations, TI intends EVMs to be used only for engineering development, demonstration, or evaluation purposes. EVMs are not finished products typically fit for general consumer use. EVMs may nonetheless generate, use, or radiate radio frequency energy, but have not been tested for compliance with the limits of computing devices pursuant to part 15 of FCC or the ICES-003 rules. Operation of such EVMs may cause interference with radio communications, in which case the user at his own expense will be required to take whatever measures may be required to correct this interference.

General Statement for EVMs including a radio

User Power/Frequency Use Obligations: For EVMs including a radio, the radio included in such EVMs is intended for development and/or professional use only in legally allocated frequency and power limits. Any use of radio frequencies and/or power availability in such EVMs and their development application(s) must comply with local laws governing radio spectrum allocation and power limits for such EVMs. It is the user's sole responsibility to only operate this radio in legally acceptable frequency space and within legally mandated power limitations. Any exceptions to this are strictly prohibited and unauthorized by TI unless user has obtained appropriate experimental and/or development licenses from local regulatory authorities, which is the sole responsibility of the user, including its acceptable authorization.

U.S. Federal Communications Commission Compliance

For EVMs Annotated as FCC – FEDERAL COMMUNICATIONS COMMISSION Part 15 Compliant

Caution

This device complies with part 15 of the FCC Rules. Operation is subject to the following two conditions: (1) This device may not cause harmful interference, and (2) this device must accept any interference received, including interference that may cause undesired operation. Changes or modifications could void the user's authority to operate the equipment.

FCC Interference Statement for Class A EVM devices

This equipment has been tested and found to comply with the limits for a Class A digital device, pursuant to part 15 of the FCC Rules. These limits are designed to provide reasonable protection against harmful interference when the equipment is operated in a commercial environment. This equipment generates, uses, and can radiate radio frequency energy and, if not installed and used in accordance with the instruction manual, may cause harmful interference to radio communications. Operation of this equipment in a residential area is likely to cause harmful interference in which case the user will be required to correct the interference at its own expense.

FCC Interference Statement for Class B EVM devices

This equipment has been tested and found to comply with the limits for a Class B digital device, pursuant to part 15 of the FCC Rules. These limits are designed to provide reasonable protection against harmful interference in a residential installation. This equipment generates, uses and can radiate radio frequency energy and, if not installed and used in accordance with the instructions, may cause harmful interference to radio communications. However, there is no guarantee that interference will not occur in a particular installation. If this equipment does cause harmful interference to radio or television reception, which can be determined by turning the equipment off and on, the user is encouraged to try to correct the interference by one or more of the following measures:

- Reorient or relocate the receiving antenna.
- Increase the separation between the equipment and receiver.
- Connect the equipment into an outlet on a circuit different from that to which the receiver is connected.
- Consult the dealer or an experienced radio/TV technician for help.

Industry Canada Compliance (English)

For EVMs Annotated as IC – INDUSTRY CANADA Compliant:

This Class A or B digital apparatus complies with Canadian ICES-003.

Changes or modifications not expressly approved by the party responsible for compliance could void the user's authority to operate the equipment.

Concerning EVMs Including Radio Transmitters

This device complies with Industry Canada licence-exempt RSS standard(s). Operation is subject to the following two conditions: (1) this device may not cause interference, and (2) this device must accept any interference, including interference that may cause undesired operation of the device.

Concerning EVMs Including Detachable Antennas

Under Industry Canada regulations, this radio transmitter may only operate using an antenna of a type and maximum (or lesser) gain approved for the transmitter by Industry Canada. To reduce potential radio interference to other users, the antenna type and its gain should be so chosen that the equivalent isotropically radiated power (e.i.r.p.) is not more than that necessary for successful communication.

This radio transmitter has been approved by Industry Canada to operate with the antenna types listed in the user guide with the maximum permissible gain and required antenna impedance for each antenna type indicated. Antenna types not included in this list, having a gain greater than the maximum gain indicated for that type, are strictly prohibited for use with this device.

Canada Industry Canada Compliance (French)

Cet appareil numérique de la classe A ou B est conforme à la norme NMB-003 du Canada

Les changements ou les modifications pas expressément approuvés par la partie responsable de la conformité ont pu vider l'autorité de l'utilisateur pour actionner l'équipement.

Concernant les EVMs avec appareils radio

Le présent appareil est conforme aux CNR d'Industrie Canada applicables aux appareils radio exempts de licence. L'exploitation est autorisée aux deux conditions suivantes : (1) l'appareil ne doit pas produire de brouillage, et (2) l'utilisateur de l'appareil doit accepter tout brouillage radioélectrique subi, même si le brouillage est susceptible d'en compromettre le fonctionnement.

Concernant les EVMs avec antennes détachables

Conformément à la réglementation d'Industrie Canada, le présent émetteur radio peut fonctionner avec une antenne d'un type et d'un gain maximal (ou inférieur) approuvé pour l'émetteur par Industrie Canada. Dans le but de réduire les risques de brouillage radioélectrique à l'intention des autres utilisateurs, il faut choisir le type d'antenne et son gain de sorte que la puissance isotrope rayonnée équivalente (p.i.r.e.) ne dépasse pas l'intensité nécessaire à l'établissement d'une communication satisfaisante.

Le présent émetteur radio a été approuvé par Industrie Canada pour fonctionner avec les types d'antenne énumérés dans le manuel d'usage et ayant un gain admissible maximal et l'impédance requise pour chaque type d'antenne. Les types d'antenne non inclus dans cette liste, ou dont le gain est supérieur au gain maximal indiqué, sont strictement interdits pour l'exploitation de l'émetteur.

Mailing Address: Texas Instruments, Post Office Box 655303, Dallas, Texas 75265
Copyright © 2014, Texas Instruments Incorporated

Important Notice for Users of EVMs Considered “Radio Frequency Products” in Japan

EVMs entering Japan are NOT certified by TI as conforming to Technical Regulations of Radio Law of Japan.

If user uses EVMs in Japan, user is required by Radio Law of Japan to follow the instructions below with respect to EVMs:

1. Use EVMs in a shielded room or any other test facility as defined in the notification #173 issued by Ministry of Internal Affairs and Communications on March 28, 2006, based on Sub-section 1.1 of Article 6 of the Ministry's Rule for Enforcement of Radio Law of Japan,
2. Use EVMs only after user obtains the license of Test Radio Station as provided in Radio Law of Japan with respect to EVMs, or
3. Use of EVMs only after user obtains the Technical Regulations Conformity Certification as provided in Radio Law of Japan with respect to EVMs. Also, do not transfer EVMs, unless user gives the same notice above to the transferee. Please note that if user does not follow the instructions above, user will be subject to penalties of Radio Law of Japan.

<http://www.tij.co.jp>

【無線電波を送信する製品の開発キットをお使いになる際の注意事項】本開発キットは技術基準適合証明を受けておりません。本製品のご使用に際しては、電波法遵守のため、以下のいずれかの措置を取っていただく必要がありますのでご注意ください。

1. 電波法施行規則第6条第1項第1号に基づく平成18年3月28日総務省告示第173号で定められた電波暗室等の試験設備でご使用いただく。
2. 実験局の免許を取得後ご使用いただく。
3. 技術基準適合証明を取得後ご使用いただく。。

なお、本製品は、上記の「ご使用にあたっての注意」を譲渡先、移転先に通知しない限り、譲渡、移転できないものとします

上記を遵守頂けない場合は、電波法の罰則が適用される可能性があることをご留意ください。

日本テキサス・インスツルメンツ株式会社

東京都新宿区西新宿 6 丁目 2 4 番 1 号

西新宿三井ビル

<http://www.tij.co.jp>

Texas Instruments Japan Limited

(address) 24-1, Nishi-Shinjuku 6 chome, Shinjuku-ku, Tokyo, Japan

IMPORTANT NOTICE

Texas Instruments Incorporated and its subsidiaries (TI) reserve the right to make corrections, enhancements, improvements and other changes to its semiconductor products and services per JESD46, latest issue, and to discontinue any product or service per JESD48, latest issue. Buyers should obtain the latest relevant information before placing orders and should verify that such information is current and complete. All semiconductor products (also referred to herein as "components") are sold subject to TI's terms and conditions of sale supplied at the time of order acknowledgment.

TI warrants performance of its components to the specifications applicable at the time of sale, in accordance with the warranty in TI's terms and conditions of sale of semiconductor products. Testing and other quality control techniques are used to the extent TI deems necessary to support this warranty. Except where mandated by applicable law, testing of all parameters of each component is not necessarily performed.

TI assumes no liability for applications assistance or the design of Buyers' products. Buyers are responsible for their products and applications using TI components. To minimize the risks associated with Buyers' products and applications, Buyers should provide adequate design and operating safeguards.

TI does not warrant or represent that any license, either express or implied, is granted under any patent right, copyright, mask work right, or other intellectual property right relating to any combination, machine, or process in which TI components or services are used. Information published by TI regarding third-party products or services does not constitute a license to use such products or services or a warranty or endorsement thereof. Use of such information may require a license from a third party under the patents or other intellectual property of the third party, or a license from TI under the patents or other intellectual property of TI.

Reproduction of significant portions of TI information in TI data books or data sheets is permissible only if reproduction is without alteration and is accompanied by all associated warranties, conditions, limitations, and notices. TI is not responsible or liable for such altered documentation. Information of third parties may be subject to additional restrictions.

Resale of TI components or services with statements different from or beyond the parameters stated by TI for that component or service voids all express and any implied warranties for the associated TI component or service and is an unfair and deceptive business practice. TI is not responsible or liable for any such statements.

Buyer acknowledges and agrees that it is solely responsible for compliance with all legal, regulatory and safety-related requirements concerning its products, and any use of TI components in its applications, notwithstanding any applications-related information or support that may be provided by TI. Buyer represents and agrees that it has all the necessary expertise to create and implement safeguards which anticipate dangerous consequences of failures, monitor failures and their consequences, lessen the likelihood of failures that might cause harm and take appropriate remedial actions. Buyer will fully indemnify TI and its representatives against any damages arising out of the use of any TI components in safety-critical applications.

In some cases, TI components may be promoted specifically to facilitate safety-related applications. With such components, TI's goal is to help enable customers to design and create their own end-product solutions that meet applicable functional safety standards and requirements. Nonetheless, such components are subject to these terms.

No TI components are authorized for use in FDA Class III (or similar life-critical medical equipment) unless authorized officers of the parties have executed a special agreement specifically governing such use.

Only those TI components which TI has specifically designated as military grade or "enhanced plastic" are designed and intended for use in military/aerospace applications or environments. Buyer acknowledges and agrees that any military or aerospace use of TI components which have **not** been so designated is solely at the Buyer's risk, and that Buyer is solely responsible for compliance with all legal and regulatory requirements in connection with such use.

TI has specifically designated certain components as meeting ISO/TS16949 requirements, mainly for automotive use. In any case of use of non-designated products, TI will not be responsible for any failure to meet ISO/TS16949.

Products

Audio	www.ti.com/audio
Amplifiers	amplifier.ti.com
Data Converters	dataconverter.ti.com
DLP® Products	www.dlp.com
DSP	dsp.ti.com
Clocks and Timers	www.ti.com/clocks
Interface	interface.ti.com
Logic	logic.ti.com
Power Mgmt	power.ti.com
Microcontrollers	microcontroller.ti.com
RFID	www.ti-rfid.com
OMAP Applications Processors	www.ti.com/omap
Wireless Connectivity	www.ti.com/wirelessconnectivity

Applications

Automotive and Transportation	www.ti.com/automotive
Communications and Telecom	www.ti.com/communications
Computers and Peripherals	www.ti.com/computers
Consumer Electronics	www.ti.com/consumer-apps
Energy and Lighting	www.ti.com/energy
Industrial	www.ti.com/industrial
Medical	www.ti.com/medical
Security	www.ti.com/security
Space, Avionics and Defense	www.ti.com/space-avionics-defense
Video and Imaging	www.ti.com/video

TI E2E Community

e2e.ti.com