

1.8/2.5/3.3 V LOW-JITTER, LOW-SKEW CLOCK BUFFER/LEVEL TRANSLATOR

Features

- Supports single-ended or differential input clock signals
- Generates four differential (LVPECL, LVDS, HCSL) or eight single-ended (CMOS, SSTL, HSTL) outputs
- Provides signal level translation
 - Differential to single-ended
 - Single-ended to differential
 - Differential to differential
 - Single-ended to single-ended
- Wide frequency range
 - LVPECL, LVDS: 5 to 710 MHz
 - HCSL: 5 to 250 MHz
 - SSTL, HSTL: 5 to 350 MHz
 - CMOS: 5 to 200 MHz
- Additive jitter: 150 fs RMS typ
- Output-output skew: 100 ps
- Propagation delay: 2.5 ns typ
- Single core supply with excellent PSRR: 1.8, 2.5, or 3.3 V
- Output driver supply voltage independent of core supply: 1.5, 1.8, 2.5, or 3.3 V
- Loss of Signal (LOS) indicator allows system clock monitoring
- Output Enable (OEB) pin allows glitchless control of output clocks
- Low power: 10 mA typical core current
- Industrial temperature range: -40 to +85 °C
- Small size: 24-lead, 4 x 4 mm QFN

Applications

- High Speed Clock Distribution
- Ethernet Switch/Router
- SONET / SDH
- PCI Express 2.0/3.0
- Fibre Channel
- MSAN/DSLAM/PON
- Telecom Line Cards

Functional Block Diagram

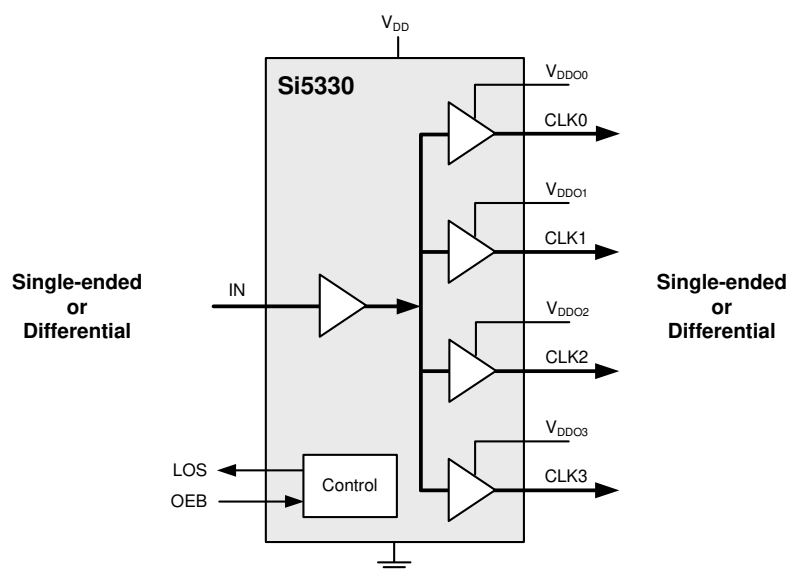

Ordering Information:
See page 14.

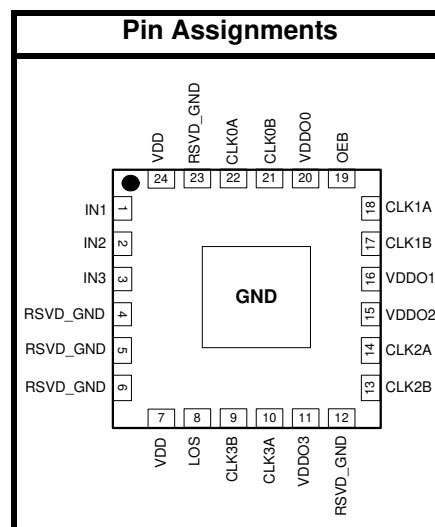

1. Functional Block Diagrams Based on Orderable Part Number*

1:4 Differential to Differential Buffer

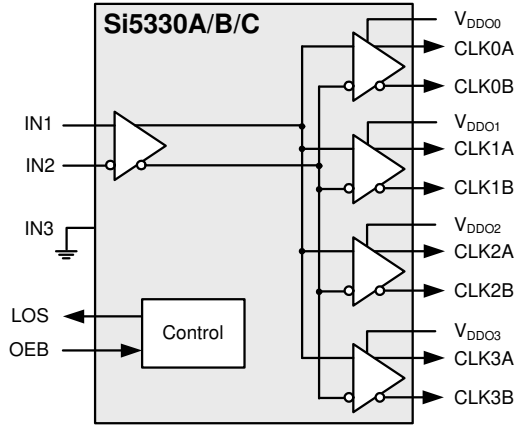

1:8 Single-Ended to Single-Ended Buffer

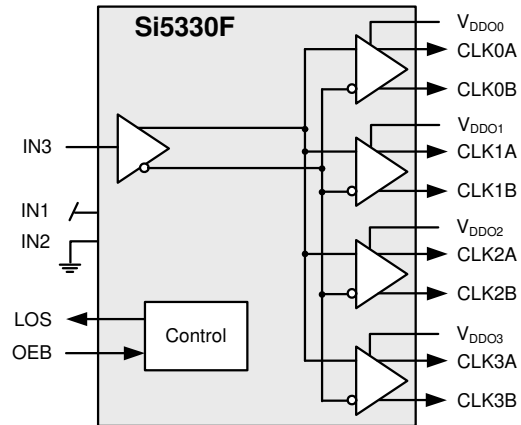

1:8 Differential to Single-Ended Buffer

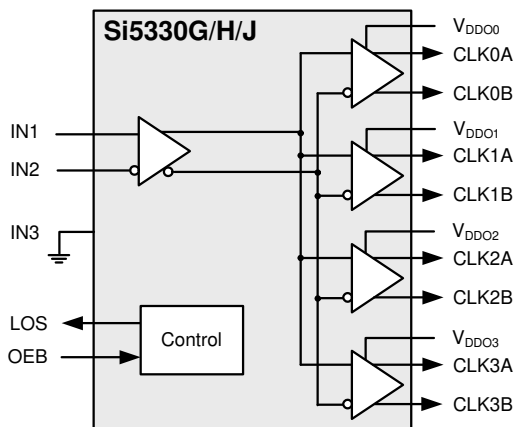

1:4 Single-Ended to Differential Buffer

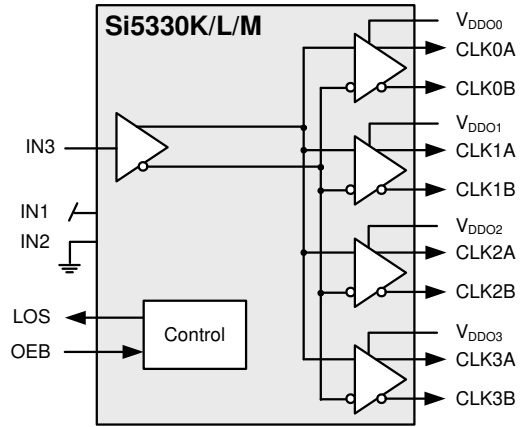

Figure 1. Si5330 Functional Block Diagrams

*Note: See Table 11 for detailed ordering information.

TABLE OF CONTENTS

<u>Section</u>	<u>Page</u>
1. Functional Block Diagrams Based on Orderable Part Number*	2
2. Electrical Specifications	4
3. Functional Description	9
3.1. VDD and VDDO Supplies	9
3.2. Loss Of Signal Indicator (LOS)	9
3.3. Output Enable (OEB)	9
3.4. Input Signals	9
3.5. Output Driver Formats	9
3.6. Input and Output Terminations	9
4. Ordering the Si5330	9
5. Pin Descriptions	10
6. Orderable Part Numbers and Device Functionality	14
7. Package Outline: 24-Lead QFN	16
8. Recommended PCB Layout	17
9. Top Marking	18
9.1. Si5330 Top Marking	18
9.2. Top Marking Explanation	18
Document Change List	19
Contact Information	20

2. Electrical Specifications

Table 1. Recommended Operating Conditions

($V_{DD} = 1.8\text{ V} -5\%$ to $+10\%$, $2.5\text{ V} \pm 10\%$, or $3.3\text{ V} \pm 10\%$, $T_A = -40$ to 85°C)

Parameter	Symbol	Test Condition	Min	Typ	Max	Unit
Ambient Temperature	T_A		-40	25	85	$^\circ\text{C}$
Core Supply Voltage	V_{DD}		2.97	3.3	3.63	V
			2.25	2.5	2.75	V
			1.71	1.8	1.98	V
Output Buffer Supply Voltage	V_{DDOn}		1.4	—	3.63	V

Note: All minimum and maximum specifications are guaranteed and apply across the recommended operating conditions. Typical values apply at nominal supply voltages and an operating temperature of $25\text{ }^\circ\text{C}$ unless otherwise noted.

Table 2. DC Characteristics

($V_{DD} = 1.8\text{ V} -5\%$ to $+10\%$, $2.5\text{ V} \pm 10\%$, or $3.3\text{ V} \pm 10\%$, $T_A = -40$ to 85°C)

Parameter	Symbol	Test Condition	Min	Typ	Max	Unit
Core Supply Current	I_{DD}	50 MHz refclk	—	10	—	mA
Output Buffer Supply Current	I_{DDOx}	LVPECL, 710 MHz	—	—	30	mA
		LVDS, 710 MHz	—	—	8	mA
		HCSL, 250 MHz 2 pF load capacitance	—	—	20	mA
		SSTL, 350 MHz	—	—	19	mA
		CMOS, 50 MHz 15 pF load capacitance	—	—	28	mA
		CMOS, 200 MHz 2 pF load capacitance	—	—	28	mA
		HSTL, 350 MHz	—	—	19	mA

Table 3. Performance Characteristics(V_{DD} = 1.8 V -5% to +10%, 2.5 V ±10%, or 3.3 V ±10%, T_A = -40 to 85°C)

Parameter	Symbol	Test Condition	Min	Typ	Max	Unit
CLKIN Loss of Signal Assert Time	t _{LOS}		—	2.6	5	μs
CLKIN Loss of Signal De-Assert Time	t _{LOS_B}	After initial start-up time has expired	0.01	0.2	1	μs
Input-to-Output Propagation Delay	t _{PROP}		—	2.5	4.0	ns
Output-Output Skew	t _{DSKEW}	Outputs at same signal format	—	—	100	ps
POR to Output Clock Valid	t _{START}	Start-up time for output clocks	—	—	2	ms

Table 4. Input and Output Clock Characteristics(V_{DD} = 1.8 V -5% to +10%, 2.5 V ±10%, or 3.3 V ±10%, T_A = -40 to 85 °C)

Parameter	Symbol	Test Condition	Min	Typ	Max	Units
Input Clock (AC Coupled Differential Input Clocks on Pin IN1/2)						
Frequency	f _{IN}		5	—	710	MHz
Differential Voltage Swing	V _{PP}	710 MHz input	0.4	—	2.4	V _{PP}
Rise/Fall Time	t _R /t _F	20%–80%	—	—	1.0	ns
Duty Cycle	DC	< 1 ns tr/ff	40	50	60	%
Input Impedance	R _{IN}		10	—	—	kΩ
Input Capacitance	C _{IN}		—	3.5	—	pF
Input Clock (DC-Coupled Single-Ended Input Clock on Pin IN3)						
Frequency	f _{IN}	CMOS	5	—	200	MHz
		HSTL, SSTL	5	—	350	MHz
Input Voltage	V _I		-0.1	—	VDD	V
Input Voltage Swing (CMOS Standard)		200 MHz, Tr/Tf = 1.3 ns	0.8	—	—	V _{pp}
Rise/Fall Time	t _R /t _F	20%–80%	—	—	4	ns
Duty Cycle	DC	< 2 ns tr/ff	40	50	60	%
Input Capacitance	C _{IN}		—	2	—	pF
Output Clocks (Differential)						
Frequency	f _{OUT}	LVPECL, LVDS	5	—	710	MHz
		HCSSL	5	—	250	MHz

Table 4. Input and Output Clock Characteristics (Continued)

($V_{DD} = 1.8\text{ V} -5\%$ to $+10\%$, $2.5\text{ V} \pm 10\%$, or $3.3\text{ V} \pm 10\%$, $T_A = -40$ to $85\text{ }^\circ\text{C}$)

Parameter	Symbol	Test Condition	Min	Typ	Max	Units
LVPECL Output Voltage	V_{OC}	common mode	—	$V_{DDO} - 1.45\text{ V}$	—	V
	V_{SEPP}	peak-to-peak single-ended swing	0.55	0.8	0.96	V_{PP}
LVDS Output Voltage (2.5/3.3 V)	V_{OC}	common mode	1.125	1.2	1.275	V
	V_{SEPP}	peak-to-peak single-ended swing	0.25	0.35	0.45	V_{PP}
LVDS Output Voltage (1.8 V)	V_{OC}	common mode	0.8	0.875	0.95	V
	V_{SEPP}	peak-to-peak single-ended swing	0.25	0.35	0.45	V_{PP}
HCSL Output Voltage	V_{OC}	common mode	0.35	0.375	0.400	V
	V_{SEPP}	peak-to-peak single-ended swing	0.575	0.725	0.85	V_{PP}
Rise/Fall Time	t_R/t_F	20%–80%	—	—	450	ps
Duty Cycle*	DC	$CK_n < 350\text{ MHz}$	45	—	55	%
		$350\text{ MHz} < CLK_n < 710\text{ MHz}$	40	—	60	%
Output Clocks (Single-Ended)						
Frequency	f_{OUT}	CMOS	5	—	200	MHz
		SSTL, HSTL	5	—	350	MHz
CMOS 20%-80% Rise/Fall Time	t_R/t_F	2 pF load	—	0.45	0.85	ns
CMOS 20%-80% Rise/Fall Time	t_R/t_F	15 pF load	—	—	1.7	ns
CMOS Output Resistance			—	50	—	Ω
SSTL Output Resistance			—	50	—	Ω
HSTL Output Resistance			—	50	—	Ω
CMOS Output Voltage	V_{OH}	4 mA load	$V_{DDO} - 0.3$	—	—	V
	V_{OL}	4 mA load	—	—	0.3	V
SSTL Output Voltage	V_{OH}	SSTL-3 $V_{DDOx} = 2.97$ to 3.63 V	$0.45 \times V_{DDO} + 0.41$	—	—	V
	V_{OL}		—	—	$0.45 \times V_{DDO} - 0.41$	V
	V_{OH}	SSTL-2 $V_{DDOx} = 2.25$ to 2.75 V	$0.5 \times V_{DDO} + 0.41$	—	—	V
	V_{OL}		—	—	$0.5 \times V_{DDO} - 0.41$	V
	V_{OH}	SSTL-18 $V_{DDOx} = 1.71$ to 1.98 V	$0.5 \times V_{DDO} + 0.34$	—	—	V
	V_{OL}		—	—	$0.5 \times V_{DDO} - 0.34$	V

Table 4. Input and Output Clock Characteristics (Continued)(V_{DD} = 1.8 V -5% to +10%, 2.5 V ±10%, or 3.3 V ±10%, T_A = -40 to 85 °C)

Parameter	Symbol	Test Condition	Min	Typ	Max	Units
HSTL Output Voltage	V _{OH}	VDDO = 1.4 to 1.6 V	0.5xVDDO +0.3	—	—	V
	V _{OL}		—	—	0.5xVDDO -0.3	V
Duty Cycle*	DC		45	—	55	%

*Note: Input clock has a 50% duty cycle.

Table 5. OEB Input Specifications

Parameter	Symbol	Test Condition	Min	Typ	Max	Unit
Input Voltage Low	V _{IL}		—	—	0.3 x V _{DD}	V
Input Voltage High	V _{IH}		0.7 x V _{DD}	—	—	V
Input Resistance	R _{IN}		20	—	—	kΩ

Table 6. Output Control Pins (LOS)(V_{DD} = 1.8 V -5% to +10%, 2.5 V ±10%, or 3.3 V ±10%, T_A = -40 to 85 °C)

Parameter	Symbol	Condition	Min	Typ	Max	Unit
Output Voltage Low	V _{OL}	I _{SINK} = 3 mA	0	—	0.4	V
Rise/Fall Time 20–80%	t _R /t _F	C _L < 10 pf, pull up ≤ 1 kΩ	—	—	10	ns

Table 7. Jitter Specifications(V_{DD} = 1.8 V -5% to +10%, 2.5 V ±10%, or 3.3 V ±10%, T_A = -40 to 85°C)

Parameter	Symbol	Test Condition	Min	Typ	Max	Unit
Additive Phase Jitter (12 kHz–20 MHz)	t _{RPHASE}	0.7 V pk-pk differential input clock at 622.08 MHz with 70 ps rise/fall time	—	0.150	—	ps RMS
Additive Phase Jitter (50 kHz–80 MHz)	t _{RPHASEWB}	0.7 V pk-pk differential input clock at 622.08 MHz with 70 ps rise/fall time	—	0.225	—	ps RMS

Table 8. Thermal Characteristics

Parameter	Symbol	Test Condition	Value	Unit
Thermal Resistance Junction to Ambient	θ _{JA}	Still Air	37	°C/W
Thermal Resistance Junction to Case	θ _{JC}	Still Air	25	°C/W

Table 9. Absolute Maximum Ratings^{1,2,3,4,5}

Parameter	Symbol	Test Condition	Value	Unit
DC Supply Voltage	V_{DD}		-0.5 to 3.8	V
Storage Temperature Range	T_{STG}		-55 to 150	°C
ESD Tolerance		HBM (100 pF, 1.5 kΩ)	2.5	kV
ESD Tolerance		CDM	550	V
ESD Tolerance		MM	175	V
Latch-up Tolerance			JESD78 Compliant	
Junction Temperature	T_J		150	°C
Soldering Temperature (Pb-free profile) ⁵	T_{PEAK}		260	°C
Soldering Temperature Time at T_{PEAK} (Pb-free profile) ⁵	T_P		20–40	sec

Notes:

1. Permanent device damage may occur if the Absolute Maximum Ratings are exceeded. Functional operation should be restricted to the conditions as specified in the operational sections of this data sheet. Exposure to maximum rating conditions for extended periods may affect device reliability.
2. 24-QFN package is RoHS compliant.
3. For more packaging information, go to www.silabs.com/support/quality/pages/RoHSInformation.aspx.
4. Moisture sensitivity level is MSL3.
5. Recommended card reflow profile is per the JEDEC/IPC J-STD-020 specification for Small Body Components.

3. Functional Description

The Si5330 is a low-jitter, low-skew fanout buffer optimized for high-performance PCB clock distribution applications. The device produces four differential or eight single-ended, low-jitter output clocks from a single input clock. The input can accept either a single-ended or a differential clock allowing the device to function as a clock level translator.

3.1. V_{DD} and V_{DDO} Supplies

The core V_{DD} and output V_{DDO} supplies have separate and independent supply pins allowing the core supply to operate at a different voltage than the I/O voltage levels.

The V_{DD} supply powers the core functions of the device, which operates from 1.8, 2.5, or 3.3 V. Using a lower supply voltage helps minimize the device's power consumption. The V_{DDO} supply pins are used to set the output signal levels and must be set at a voltage level compatible with the output signal format.

3.2. Loss Of Signal Indicator (LOS)

The input is monitored for a valid clock signal using an LOS circuit that monitors input clock edges and declares an LOS condition when signal edges are not detected over a 1 to 5 μ s observation period. The LOS pin is asserted "low" when activity on the input clock pin is present. A "high" level on the LOS pin indicates a loss of signal (LOS). The LOS pin must be pulled to V_{DD} as shown in Figure 2.

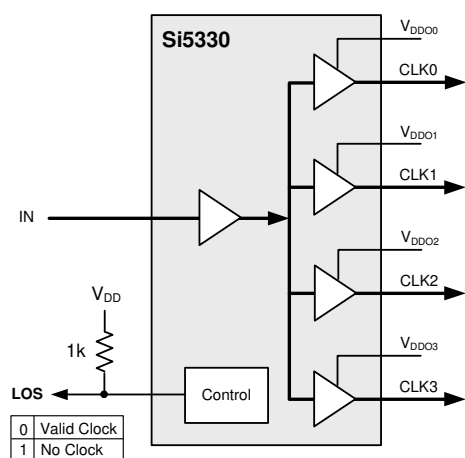

Figure 2. LOS Indicator with External Pull-Up

3.3. Output Enable (OEB)

The output enable (OEB) pin allows disabling or enabling of the outputs clocks (CLK0-CLK3). The output enable is logically controlled to ensure that no glitches or runt pulses are generated at the output as shown in Figure 3.

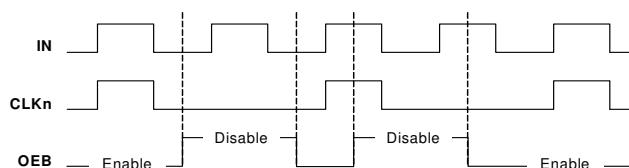

Figure 3. OEB Glitchless Operation

All outputs are enabled when the OEB pin is connected to ground or below the V_{IL} voltage for this pin. Connecting the OEB pin to V_{DD} or above the V_{IH} level will disable the outputs. Both V_{IL} and V_{IH} are specified in Table 5. All outputs are forced to a logic "low" when disabled. The OEB pin is 3.3 V tolerant.

3.4. Input Signals

The Si5330 can accept single-ended and differential input clocks. See "AN408: Termination Options for Any-Frequency, Any-Output Clock Generators and Clock Buffers—Si5338, Si5334, Si5330" for details on connecting a wide variety of signals to the Si5330 inputs.

3.5. Output Driver Formats

The Si5330 supports single-ended output formats of CMOS, SSTL, and HSTL and differential formats of LVDS, LVPECL, and HCSL. It is normally required that the LVDS driver be dc-coupled to the 100 Ω termination at the receiver end. If your application requires an ac-coupled 100 Ω load, contact the applications team for advice. See AN408 for additional information on the terminations for these driver types.

3.6. Input and Output Terminations

See AN408 for detailed information.

4. Ordering the Si5330

The Si5330 can be ordered to meet the requirements of the most commonly-used input and output signal types, such as CMOS, SSTL, HSTL, LVPECL, LVDS, and HSCL. See Figure 1, "Si5330 Functional Block Diagrams," on page 2 and Table 11, "Order Numbers and Device Functionality," on page 14 for specific ordering information.

5. Pin Descriptions

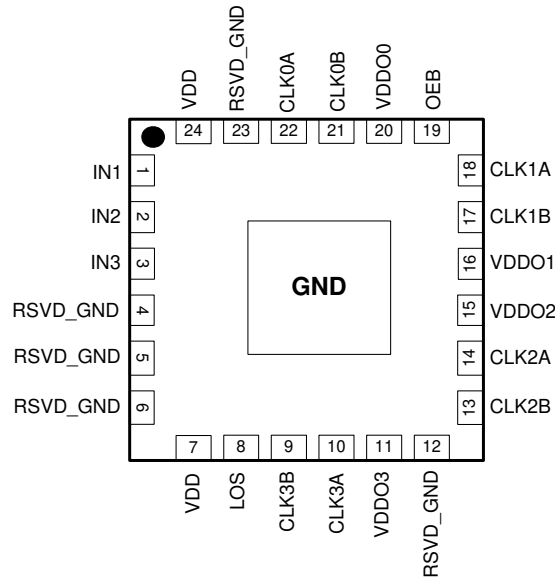

Note: Center pad must be tied to GND for normal operation.

Table 10. Si5330 Pin Descriptions

Pin #	Pin Name	I/O	Signal Type	Description
1	IN1	I	Multi	Si5330A/B/C/G/H/J Differential Input Devices.
2	IN2	I	Multi	These pins are used as the differential clock input. IN1 is the positive input; IN2 is the negative input. Refer to “AN408: Termination Options for Any-Frequency, Any-Output Clock Generators and Clock Buffers—Si5338, Si5334, Si5330” for interfacing and termination details. Si5330F/K/L/M Single-Ended Input Devices. These pins are not used. Leave IN1 unconnected and IN2 connected to ground.
3	IN3	I	Multi	Si5330F/K/L/M Single-Ended Devices. This is the single-ended clock input. Refer to AN408 for interfacing and termination details. Si5330A/B/C/G/H/J Differential Input Devices. This pin is not used. Connect to ground.
4	RSVD_GND			Ground. Must be connected to system ground.
5	RSVD_GND			Ground. Must be connected to system ground.
6	RSVD_GND			Ground. Must be connected to system ground.

Table 10. Si5330 Pin Descriptions (Continued)

Pin #	Pin Name	I/O	Signal Type	Description
7	VDD	VDD	Supply	Core Supply Voltage. The device operates from a 1.8, 2.5, or 3.3 V supply. A 0.1 μ F bypass capacitor should be located very close to this pin.
8	LOS	O	Open Drain	Loss of Signal Indicator. 0 = CLKIN present. 1 = Loss of signal (LOS). This pin requires an external ≥ 1 k Ω pull-up resistor.
9	CLK3B	O	Multi	Si5330A/B/C/K/L/M Differential Output Devices. This is the negative side of the differential CLK3 output. Refer to AN408 for interfacing and termination details. Leave unconnected when not in use. Si5330F/G/H/J Single-Ended Output Devices. This is one of the single-ended CLK3 outputs. Both CLK3A and CLK3B single-ended outputs are in phase. Refer to AN408 for interfacing and termination details. Leave unconnected when not is use.
10	CLK3A	O	Multi	Si5330A/B/C/K/L/M Differential Devices. This is the positive side of the differential CLK3 output. Refer to AN408 for interfacing and termination details. Leave unconnected when not in use. Si5330F/G/H/J Single-Ended Devices. This is one of the single-ended CLK3 outputs. Both CLK3A and CLK3B single-ended outputs are in phase. Refer to AN408 for interfacing and termination details. Leave unconnected when not is use.
11	VDDO3	VDD	Supply	Output Clock Supply Voltage. Supply voltage for CLK3A/B. Use a 0.1 μ F bypass cap as close as possible to this pin. If CLK3 is not used, this pin must be tied to V_{DD} (pin 7 and/or pin 24).
12	RSVD_GND			Ground. Must be connected to system ground.
13	CLK2B	O	Multi	Si5330A/B/C/K/L/M Differential Output Devices. This is the negative side of the differential CLK2 output. Refer to AN408 for interfacing and termination details. Leave unconnected when not in use. Si5330F/G/H/J Single-Ended Output Devices. This is one of the single-ended CLK2 outputs. Both CLK2A and CLK2B single-ended outputs are in phase. Refer to AN408 for interfacing and termination details. Leave unconnected when not is use.

Table 10. Si5330 Pin Descriptions (Continued)

Pin #	Pin Name	I/O	Signal Type	Description
14	CLK2A	O	Multi	<p>Si5330A/B/C/K/L/M Differential Devices. This is the positive side of the differential CLK2 output. Refer to AN408 for interfacing and termination details. Leave unconnected when not in use.</p> <p>Si5330F/G/H/J Single-Ended Devices. This is one of the single-ended CLK2 outputs. Both CLK2A and CLK2B single-ended outputs are in phase. Refer to AN408 for interfacing and termination details. Leave unconnected when not is use.</p>
15	VDDO2	VDD	Supply	<p>Output Clock Supply Voltage. Supply voltage for CLK2A/B. Use a 0.1 μF bypass cap as close as possible to this pin. If CLK2 is not used, this pin must be tied to V_{DD} (pin 7 and/or pin 24).</p>
16	VDDO1	VDD	Supply	<p>Output Clock Supply Voltage. Supply voltage for CLK1A,B. Use a 0.1 μF bypass cap as close as possible to this pin. If CLK1 is not used, this pin must be tied to V_{DD} (pin 7 and/or pin 24).</p>
17	CLK1B	O	Multi	<p>Si5330A/B/C/K/L/M Differential Output Devices. This is the negative side of the differential CLK1 output. Refer to AN408 for interfacing and termination details. Leave unconnected when not in use.</p> <p>Si5330F/G/H/J Single-Ended Output Devices. This is one of the single-ended CLK1 outputs. Both CLK1A and CLK1B single-ended outputs are in phase. Refer to AN408 for interfacing and termination details. Leave unconnected when not is use.</p>
18	CLK1A	O	Multi	<p>Si5330A/B/C/K/L/M Differential Devices. This is the positive side of the differential CLK1 output. Refer to AN408 for interfacing and termination details. Leave unconnected when not in use.</p> <p>Si5330F/G/H/J Single-Ended Devices. This is one of the single-ended CLK1 outputs. Both CLK1A and CLK1B single-ended outputs are in phase. Refer to AN408 for interfacing and termination details. Leave unconnected when not is use.</p>
19	OEB	I	CMOS	<p>Output Enable. All outputs are enabled when the OEB pin is connected to ground or below the V_{IL} voltage for this pin. Connecting the OEB pin to V_{DD} or above the V_{IH} level will disable the outputs. Both V_{IL} and V_{IH} are specified in Table 5. All outputs are forced to a logic "low" when disabled. This pin is 3.3 V tolerant.</p>
20	VDDO0	VDD	Supply	<p>Output Clock Supply Voltage. Supply voltage for CLK0A,B. Use a 0.1 μF bypass cap as close as possible to this pin. If CLK2 is not used, this pin must be tied to V_{DD} (pin 7 and/or pin 24).</p>

Table 10. Si5330 Pin Descriptions (Continued)

Pin #	Pin Name	I/O	Signal Type	Description
21	CLK0B	O	Multi	<p>Si5330A/B/C/K/L/M Differential Output Devices. This is the negative side of the differential CLK0 output. Refer to AN408 for interfacing and termination details. Leave unconnected when not in use.</p> <p>Si5330F/G/H/J Single-ended Output Devices. This is one of the single-ended CLK0 outputs. Both CLK0A and CLK0B single-ended outputs are in phase. Refer to AN408 for interfacing and termination details. Leave unconnected when not is use.</p>
22	CLK0A	O	Multi	<p>Si5330A/B/C/K/L/M Differential Devices. This is the positive side of the differential CLK0 output. Refer to AN408 for interfacing and termination details. Leave unconnected when not in use.</p> <p>Si5330F/G/H/J Single-ended Devices. This is one of the single-ended CLK0 outputs. Both CLK0A and CLK0B single-ended outputs are in phase. Refer to AN408 for interfacing and termination details. Leave unconnected when not is use.</p>
23	RSVD_GND			<p>Ground. Must be connected to system ground.</p>
24	VDD	VDD	Supply	<p>Core Supply Voltage. The device operates from a 1.8, 2.5, or 3.3 V supply. A 0.1 μF bypass capacitor should be located very close to this pin.</p>
GND PAD	GND	GND	Supply	<p>Ground Pad. This is main ground connection for this device. It is located at the bottom center of the package. Use as many vias as possible to connect this pad to the main ground plane. The device will not function as specified unless this ground pad is properly connected to ground.</p>

6. Orderable Part Numbers and Device Functionality

Table 11. Order Numbers and Device Functionality

Part Number ^{1,2}	Input Signal Format	Output Signal Format	Number of Outputs	Frequency Range
LVPECL Buffers				
Si5330A-A00200-GM	Differential	3.3 V LVPECL	4	5 to 710 MHz
Si5330A-A00202-GM	Differential	2.5 V LVPECL	4	5 to 710 MHz
LVDS Buffers				
Si5330B-A00204-GM	Differential	3.3 V LVDS	4	5 to 710 MHz
Si5330B-A00205-GM	Differential	2.5 V LVDS	4	5 to 710 MHz
Si5330B-A00206-GM	Differential	1.8 V LVDS	4	5 to 710 MHz
HCSL Buffers				
Si5330C-A00207-GM	Differential	3.3 V HCSL	4	5 to 250 MHz
Si5330C-A00208-GM	Differential	2.5 V HCSL	4	5 to 250 MHz
Si5330C-A00209-GM	Differential	1.8 V HCSL	4	5 to 250 MHz
CMOS Buffers				
Si5330F-A00214-GM	Single-Ended	3.3 V CMOS	8	5 to 200 MHz
Si5330F-A00215-GM	Single-Ended	2.5 V CMOS	8	5 to 200 MHz
Si5330F-A00216-GM	Single-Ended	1.8 V CMOS	8	5 to 200 MHz
CMOS Buffers (Differential Input)				
Si5330G-A00217-GM	Differential	3.3 V CMOS	8	5 to 200 MHz
Si5330G-A00218-GM	Differential	2.5 V CMOS	8	5 to 200 MHz
Si5330G-A00219-GM	Differential	1.8 V CMOS	8	5 to 200 MHz
SSTL Buffers (Differential Input)				
Si5330H-A00220-GM	Differential	3.3 V SSTL	8	5 to 350 MHz
Si5330H-A00221-GM	Differential	2.5 V SSTL	8	5 to 350 MHz
Si5330H-A00222-GM	Differential	1.8 V SSTL	8	5 to 350 MHz
HSTL Buffers (Differential Input)				
Si5330J-A00223-GM	Differential	1.5 V HSTL	8	5 to 350 MHz
LVPECL Buffers (Single-Ended Input)				
Si5330K-A00224-GM	Single-Ended	3.3 V LVPECL	4	5 to 350 MHz
Si5330K-A00226-GM	Single-Ended	2.5 V LVPECL	4	5 to 350 MHz
Notes:				
1. Custom configurations with mixed output types are also available. Please contact the factory for ordering details.				
2. Add an "R" to the part number to specify tape and reel shipment media. When specifying non-tape-and-reel shipment media, contact your sales representative for more information.				

Table 11. Order Numbers and Device Functionality (Continued)

Part Number ^{1,2}	Input Signal Format	Output Signal Format	Number of Outputs	Frequency Range
LVDS Buffers (Single-Ended Input)				
Si5330L-A00228-GM	Single-Ended	3.3 V LVDS	4	5 to 350 MHz
Si5330L-A00229-GM	Single-Ended	2.5 V LVDS	4	5 to 350 MHz
Si5330L-A00230-GM	Single-Ended	1.8 V LVDS	4	5 to 350 MHz
HCSL Buffers (Single-Ended Input)				
Si5330M-A00231-GM	Single-Ended	3.3 V HCSL	4	5 to 250 MHz
Si5330M-A00232-GM	Single-Ended	2.5 V HCSL	4	5 to 250 MHz
Si5330M-A00233-GM	Single-Ended	1.8 V HCSL	4	5 to 250 MHz
Notes:				
<ol style="list-style-type: none"> 1. Custom configurations with mixed output types are also available. Please contact the factory for ordering details. 2. Add an "R" to the part number to specify tape and reel shipment media. When specifying non-tape-and-reel shipment media, contact your sales representative for more information. 				

7. Package Outline: 24-Lead QFN

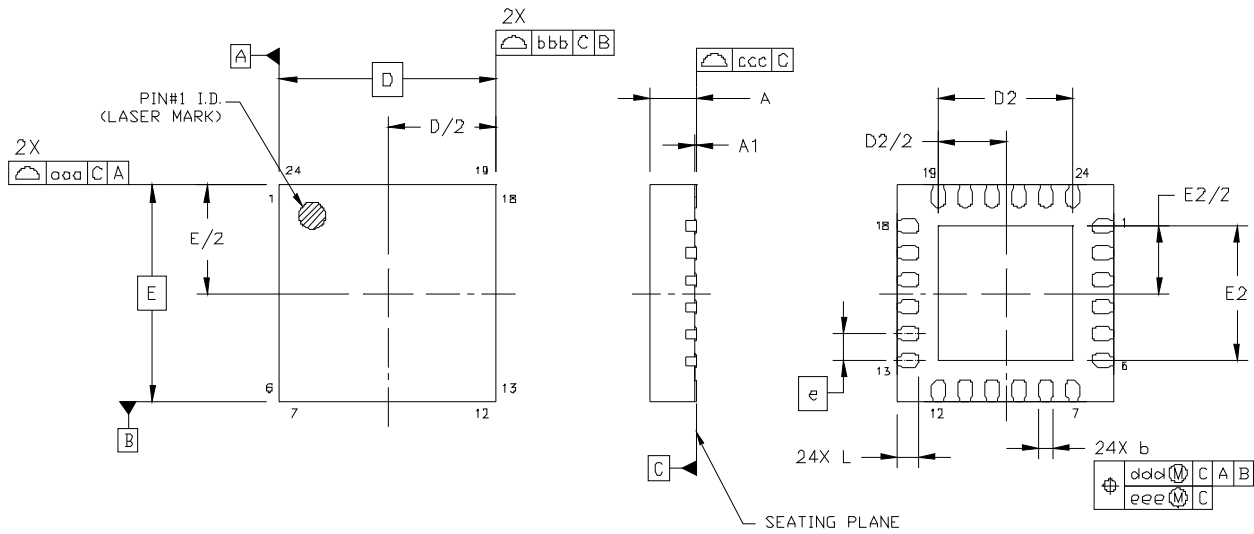

Figure 4. 24-Lead Quad Flat No-Lead (QFN)

Table 12. Package Dimensions

Dimension	Min	Nom	Max
A	0.80	0.85	0.90
A1	0.00	0.02	0.05
b	0.18	0.25	0.30
D	4.00 BSC.		
D2	2.35	2.50	2.65
e	0.50 BSC.		
E	4.00 BSC.		
E2	2.35	2.50	2.65
L	0.30	0.40	0.50
aaa	0.10		
bbb	0.10		
ccc	0.08		
ddd	0.10		
eee	0.05		

Notes:

1. All dimensions shown are in millimeters (mm) unless otherwise noted.
2. Dimensioning and Tolerancing per ANSI Y14.5M-1994.
3. This drawing conforms to the JEDEC Outline MO-220, variation VGGD-8.
4. Recommended card reflow profile is per the JEDEC/IPC J-STD-020 specification for Small Body Components.
5. J-STD-020 MSL rating: MSL3.
6. Terminal base alloy: Cu.
7. Terminal plating/grid array material: Au/NiPd.
8. For more packaging information, go to www.silabs.com/support/quality/pages/RoHSInformation.aspx.

8. Recommended PCB Layout

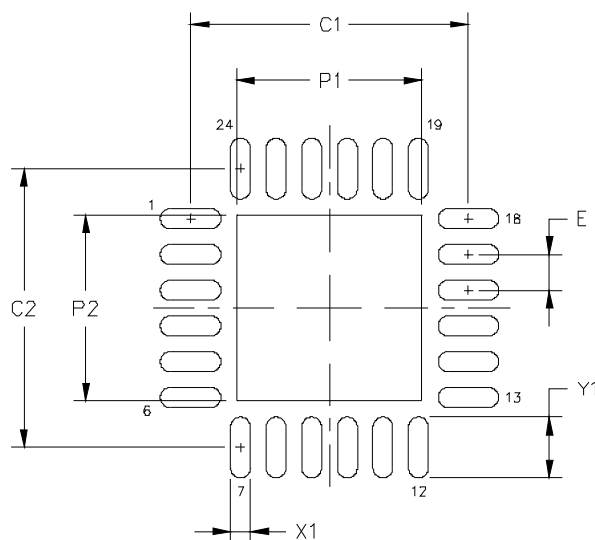

Table 13. PCB Land Pattern

Dimension	Min	Nom	Max
P1	2.50	2.55	2.60
P2	2.50	2.55	2.60
X1	0.20	0.25	0.30
Y1	0.75	0.80	0.85
C1		3.90	
C2		3.90	
E		0.50	

Notes:

General

- All dimensions shown are in millimeters (mm) unless otherwise noted.
- Dimensioning and Tolerancing per ANSI Y14.5M-1994 specification.
- This Land Pattern Design is based on the IPC-7351 guidelines.
- Connect the center ground pad to a ground plane with no less than five vias to a ground plane that is no more than 20 mils below it. Via drill size should be no smaller than 10 mils. A longer distance to the ground plane is allowed if more vias are used to keep the inductance from increasing.

Solder Mask Design

- All metal pads are to be non-solder mask defined (NSMD). Clearance between the solder mask and the metal pad is to be 60 μm minimum, all the way around the pad.

Stencil Design

- A stainless steel, laser-cut and electro-polished stencil with trapezoidal walls should be used to assure good solder paste release.
- The stencil thickness should be 0.125 mm (5 mils).
- The ratio of stencil aperture to land pad size should be 1:1 for all perimeter pins.
- A 2x2 array of 1.0 mm square openings on 1.25 mm pitch should be used for the center ground pad.

Card Assembly

- A No-Clean, Type-3 solder paste is recommended.
- The recommended card reflow profile is per the JEDEC/IPC J-STD-020C specification for Small Body Components.

Si5330

9. Top Marking

9.1. Si5330 Top Marking

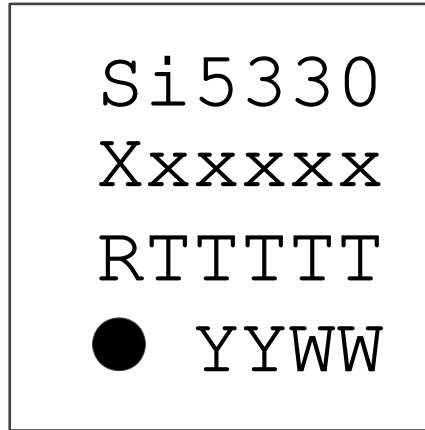

9.2. Top Marking Explanation

Mark Method:	Laser	
Line 1 Marking:	Device Part Number	Si5330
Line 2 Marking:	X = Frequency and configuration code. xxxxx = Input and output format configuration code. See "6. Orderable Part Numbers and Device Functionality" on page 14 for more information.	Xxxxxx
Line 3 Marking:	R = Product revision (A). TTTTT = Manufacturing trace code.	RTTTT
Line 4 Marking:	Pin 1 indicator.	Circle with 0.5 mm diameter; left-justified
	YY = Year. WW = Work week. Characters correspond to the year and work week of package assembly.	YYWW

DOCUMENT CHANGE LIST

Revision 0.1 to Revision 0.2

- Clarified documentation to reflect that Pin 19 is OEB (OE Enable Low).
- Updated Table 4, “Jitter Specifications” on page 7.

Revision 0.2 to Revision 0.3

- Major editorial updates to improve clarity.
- Updated “Additive Jitter” Specification Table.
- Updated “Core Supply Current” Specification in Table 2.
- Removed the Low-Power LVPECL output options from the ordering table in section 6.
- Removed D/E ordering options.

Revision 0.3 to Revision 0.35

- Typo of 150 ps on front page changed to 150 fs.
- Updated PCB layout notes.
- Added no ac coupling for LVDS outputs.
- Changed input rise/fall time spec to 2 ns.

Revision 0.35 to Revision 1.0

- Added maximum junction temperature specification to Table 9 on page 8.
- Added minimum and maximum duty cycle specifications to Table 4 on page 5.
- Updated Table 3, “Performance Characteristics,” on page 5.
 - Added maximum propagation delay spec (4 ns).
 - Added test condition to t_{LOS_B} in Table 3 on page 5.
 - Removed reference to frequency in Output-Output Skew.
- Updated Table 4, “Input and Output Clock Characteristics,” on page 5.
 - Input voltage (max) changed “3.63” to “VDD”
 - Input voltage swing (max) change “3.63” with “—”.
- Added Table 6, “Output Control Pins (LOS),” on page 7.
- Added tape and reel ordering information to “6. Orderable Part Numbers and Device Functionality” on page 14.
- Added “9. Top Marking” on page 18.

CONTACT INFORMATION

Silicon Laboratories Inc.

400 West Cesar Chavez
Austin, TX 78701
Tel: 1+(512) 416-8500
Fax: 1+(512) 416-9669
Toll Free: 1+(877) 444-3032

Please visit the Silicon Labs Technical Support web page:
<https://www.silabs.com/support/pages/contacttechnicalsupport.aspx>
and register to submit a technical support request.

The information in this document is believed to be accurate in all respects at the time of publication but is subject to change without notice. Silicon Laboratories assumes no responsibility for errors and omissions, and disclaims responsibility for any consequences resulting from the use of information included herein. Additionally, Silicon Laboratories assumes no responsibility for the functioning of undescribed features or parameters. Silicon Laboratories reserves the right to make changes without further notice. Silicon Laboratories makes no warranty, representation or guarantee regarding the suitability of its products for any particular purpose, nor does Silicon Laboratories assume any liability arising out of the application or use of any product or circuit, and specifically disclaims any and all liability, including without limitation consequential or incidental damages. Silicon Laboratories products are not designed, intended, or authorized for use in applications intended to support or sustain life, or for any other application in which the failure of the Silicon Laboratories product could create a situation where personal injury or death may occur. Should Buyer purchase or use Silicon Laboratories products for any such unintended or unauthorized application, Buyer shall indemnify and hold Silicon Laboratories harmless against all claims and damages.

Silicon Laboratories and Silicon Labs are trademarks of Silicon Laboratories Inc.
Other products or brandnames mentioned herein are trademarks or registered trademarks of their respective holders.