

ATLANTIC VERSION TERMINATOR INTERFACE ADAPTER	PART NUMBER	REVISION	DESCRIPTION	FEED TYPE	
	2266553-1	C	FINE CRIMP HEIGHT ADJUST	MECHANICAL	SUPERSEDED BY 5-2151014-1
	2266553-2	C	FINE CRIMP HEIGHT ADJUST	PNEUMATIC	SUPERSEDED BY 5-2151014-2
	2266553-5	C	FINE CRIMP HEIGHT ADJUST	SERVO LATCH PLATE <sup>4</sup>	OBSOLETE
	2266553-6	C	NON CRIMP HEIGHT ADJUST	SERVO LATCH PLATE <sup>4</sup>	OBSOLETE
	2266553-7	C	FINE CRIMP HEIGHT ADJUST	NONE	OBSOLETE
	7-2266553-7	A	CRIMP TOOLING KIT	-	

APPLICATOR DATA		
CRIMP	SIZE	TYPE
WIRE	1.07 mm [.042]	F
INSUL	1.22 mm [.048]	O

APPLICATOR INSTRUCTIONS  
408-10389

TERMINAL DATA: TE TERMINAL	TE CRIMP SPECIFICATION
TERMINAL NAME: PIN & SOCKET SIZE 22 DF, AMPLIMITE	
WIRE STRIP LENGTH 3.18-3.96 mm [.125-.156 IN]	INSULATION DIAMETER RANGE Ø0.76-1.02 mm [.030-.040 IN]
TERMINAL APPLICATION SPECIFICATION 114-10001	

TERMINALS APPLIED <sup>4</sup>				
TE TERMINAL	TE TERMINAL	TE TERMINAL	TE TERMINAL	Y CONNECT
1658670-1	748333-1	748610-1	1572142-1	CD4CT3
1658670-3	748333-9	748610-8	1572143-1	CD4CT4
1658670-6	1-748333-3	1658686-1		
1658686-3	1658686-5			

WIRE SIZE	CRIMP HEIGHT mm [INCH]	CRIMP HEIGHT REFERENCE SETTING
22 AWG	0.86+/-0.03 [.034+/- .001]	7.7
24 AWG	0.76+/-0.03 [.030+/- .001]	9.4
26 AWG	0.69+/-0.03 [.027+/- .001]	9.8
28 AWG	0.64+/-0.03 [.025+/- .001]	10.3

- <sup>1</sup> RECOMMENDED SPARE PARTS
- <sup>2</sup> GREASE BEARING SURFACES LIGHTLY
- 3. LUBRICATE DAILY PER THE APPLICATOR INSTRUCTION SHEET SUPPLIED WITH THE APPLICATOR.
- <sup>4</sup> APPLICATOR SPECIFIC DATA TO BE ENTERED INTO BLANK MEMORY CHIP AT ASSEMBLY. SEE BELOW FOR PART NUMBER:  
MECHANICAL FEED WITH "SMART APPLICATOR" CONVERSION: 8-2266553-4  
PNEUMATIC FEED WITH "SMART APPLICATOR" CONVERSION: 8-2266553-4  
SERVO FEED WITH "FINE CRIMP HEIGHT ADJUST": 8-2266553-5  
SERVO FEED WITH "NON-CRIMP HEIGHT ADJUST": 8-2266553-6
- 5. ADJUSTMENT OF THE STRIPPER MAY BE REQUIRED WHEN MOVING THE APPLICATOR BETWEEN BENCH AND LEADMAKER APPLICATIONS.
- <sup>6</sup> APPLY PART NUMBER 1-23419-5 LOCTITE TO THREADS OF ITEM 62 & 180. APPLY PART NUMBER 2-23419-6 LOCTITE TO THREADS OF ITEM 242. FOR -6 ONLY APPLY PART NUMBER 1-23419-5 LOCTITE TO THREADS OF ITEM 37 & 180.
- <sup>7</sup> GREASE THREADS, GROOVE AND O-RING ON ITEMS 35 & 252.
- <sup>8</sup> MAGNET, ITEM 166 MUST BE ORIENTED CORRECTLY IN ORDER TO PROPERLY ACTUATE THE COUNTER.
- <sup>9</sup> CRIMP HEIGHT REFERENCE SETTING WAS THE SETTING USED WHEN THE APPLICATOR WAS QUALIFIED AT THE FACTORY. ADJUSTMENT MAY BE NECESSARY WHEN RUNNING APPLICATOR IN THE FIELD.
- <sup>10</sup> SPARE FEED CAM STORAGE LOCATION REFER TO INSTRUCTION SHEET FOR ADDITIONAL INFORMATION.
- <sup>11</sup> TO CONVERT THE APPLICATOR TO A NON-CARRIER CUTTING STYLE, REMOVE ITEM 13 AND ATTACH TO THE LOCATION ON THE BACK SIDE OF THE HOUSING. REFER TO INSTRUCTION SHEET FOR ADDITIONAL INFORMATION.
- <sup>12</sup> WHEN ASSEMBLING A NON CRIMP HEIGHT ADJUST APPLICATOR (-6) USE SHIMS FROM ITEM 260 TO ACHIEVE A NOMINAL SHIM HEIGHT OF 4.94.
- <sup>13</sup> THIS APPLICATOR IS SPECIFIC FOR USE IN A STRIPPER SEAL TERMINATING UNIT.
- <sup>14</sup> TERMINAL LUBRICANT IS RECOMMENDED.

**\*WARNING**  
ON INSTALLATION, SET WIRE DISC, ITEM 40 TO LARGEST WIRE SIZE SETTING. USE OF SETTINGS BELOW MINIMUM REQUIRED CRIMP HEIGHT SETTING WILL CAUSE DAMAGE TO CRIMP TOOLING.

-	-	1	-	-	-	2119957-2	APPLICATOR SHIM PACK	260
-	1	-	1	1	1	8-21084-0	O-RING, .676 ID, .070 DIA. MAT.	252
-	-	-	-	1	-	2119640-1	PUSH ROD, AIR FEED	250
-	-	-	-	1	-	2079988-1	BUSHING, LCH5-12, MISUMI	249
-	-	-	-	1	-	2119641-1	FEED CAM, AIR FEED	248
-	1	-	1	1	1	2119798-1	DETENT PIN	247
-	1	-	1	1	1	1-22279-3	SPRING, COMPRESSION	246
-	-	1	-	-	-	2119758-1	RAM, AMP STYLE, SIDE FEED, NON-ADJ.	245
-	1	1	1	1	1	2119082-5	CAM, SNAIL, INSULATION ADJUSTMENT	244
-	1	1	1	1	1	2079764-1	WASHER, WAVE SPRING, CREST-TO-CREST	243
-77	-7	-6	-5	-2	-1	PART NO	DESCRIPTION	ITEM NO

**ATLANTIC VERSION**  
Shown on sheets 1 of 4 & 2 of 4  
(Pacific version shown on sheets 3 of 4 & 4 of 4)

SET UP GAUGE	LOC	DIST	REVISIONS					
2119599-1	A	66	P	LTN	DESCRIPTION	DATE	OWN	APVD
			B		ECR-15-012717	27AUG2015	MR	GB
			C		ECR-15-017145	24NOV2015	XZ	TE
			C1		ECR-17-001723	07FEB2017	MZ	KZ
			C2		ECR-18-007745	22MAY2018	JAH	JDG

<sup>6</sup>	-	1	1	1	1	1	2119083-1	RETAINER, INSULATION DIAL	242
	-	1	1	1	1	1	7-18023-7	SCR, SKT HD CAP M3 X 4.0	241
	-	-	2	-	-	-	2168400-6	SHCS, LOW HEAD, RoHS, M5 X 16	240
	-	-	-	-	-	1	2119580-1	MECHANICAL FEED ASSEMBLY	239
	-	-	-	-	-	1	2063440-1	AIR FEED MODULE	238
	-	-	1	1	-	-	2119740-2	TAG, IDENTIFICATION	213
	-	-	1	1	-	-	1901094-3	SPACER, FEEDER	198
	-	1	1	1	1	1	4-1722335-3	STRIPPER, SIDE FEED	182
	-	1	1	1	1	1	1-5018030-0	NUT, HEX, REG, RoHS, M3.5	181
<sup>6</sup>	-	1	1	1	1	1	1-1752354-9	STANDOFF, HOLD-DOWN	180
	-	1	1	1	1	1	993111-1	PIN, SLOTTED SPRING 3.0 X 20.0	177
	-	1	1	1	1	1	5-22280-0	SPRING, COMPRESSION	176
	-	1	1	1	1	1	1752353-3	GUIDE PIN, HOLDDOWN	175
	-	1	1	1	1	1	1901680-2	GUIDE PIN, HOLDDOWN	174
	-	-	-	-	2	-	21045-3	RING, RETAIN, EXTERN, 3/16 CRESCENT	172
	-	1	1	1	1	1	994969-1	MAGNET, RARE EARTH HIGH ENERGY	166
	-	REF	REF	REF	REF	REF	994970-2	COUNTER, MAGNETIC	164
	-	-	-	-	1	-	240638-1	SPRING, FEED FINGER	163
	-	-	-	-	1	-	3-23627-7	PIN, RETAIN, GRVD, 3/16 X .854	137
	-	-	-	-	1	-	2119799-1	HOLDER, FEED FINGER, AF	136
	-	-	REF	REF	-	-	SEE NOTE 4	MEMORY CHIP, PROGRAMMED	135
	-	-	1	1	-	-	1633743-1	SERVO FEED LATCH ASM	133
	-	-	REF	REF	-	-	2119944-1	FEED FINGER ASSEMBLY, SF	117
	-	1	1	1	1	1	2119955-1	ASSY, LUBRICATOR, SIDE FEED	113
	-	1	1	1	1	1	455888-5	SPACER, CRIMPER	82
	-	1	1	1	1	1	5-547505-2	SPRING, COMPRESSION	77
	-	1	1	1	1	1	854769-4	HOLDER, INS	74
	-	1	1	1	1	1	2119956-1	DOCUMENTATION PACKAGE	71
	-	1	-	-	1	1	2119740-1	TAG, IDENTIFICATION	67
	-	2	2	2	2	2	2168078-1	SCREW, DRIVE, RH, RoHS, 2 x .188	66
	-	1	-	1	1	1	2119793-1	LIMITER, ADJUSTMENT BOLT	63
<sup>6</sup>	-	3	-	3	3	3	992763-5	SCR, SET, SOC, CONE PNT, M3 X 4.0	62
	-	1	1	1	1	1	2079383-4	SCR, BHSC, RoHS (M4 X 8)	60
	-	-	-	-	1	1	5-18022-5	SCR, HEX HD CAP, M4 X 6.0	59
	-	1	1	1	1	1	21028-2	PIN, SLOTTED SPRING .062 X .250	58
	-	-	-	-	1	1	1338685-1	PAWL, FEED	56
	-	4	4	4	4	4	2168400-1	SHCS, LOW HEAD, RoHS, M4 X 12	54
	-	2	2	2	2	2	2168083-3	SCR, SKT HD CAP, RoHS, M4 X 12.0	53
	-	1	1	1	1	1	5018030-1	NUT, HEX, REG, RoHS, M3	52
	-	1	1	1	1	1	811242-5	BUMPER, HOLD DOWN	51
	-	1	1	1	1	1	690753-2	SPACER, TONKER	50
	-	-	-	-	1	2	18023-9	SCR, SKT HD CAP M4 X 6.0	49
	-	-	-	-	1	-	2119652-1	FEED CAM, PRE FEED	48
	-	-	-	-	1	-	2119653-1	FEED CAM, POST FEED	47
	-	1	1	1	1	1	2-2119656-1	APPLICATOR BASIC ASSEMBLY, SF	46
	-	1	-	1	1	1	2119370-1	RAM, AMP STYLE, SIDE FEED	44
	-	1	1	1	1	1	2079383-7	SCR, BHSC, RoHS (M8 X 25)	41
	-	1	-	1	1	1	2119645-1	DISC, NUMBERED FA WIRE ADJUSTMENT	40
	-	1	-	1	1	1	2119957-1	APPLICATOR SHIM PACK	39
	-	1	1	1	1	1	2119644-1	RAM WASHER, PRECISION	38
<sup>6</sup>	-	1	1	1	1	1	2119085-1	FA HEAD, ATLANTIC STYLE	37
<sup>7</sup>	-	1	-	1	1	1	2119092-1	BOLT, ADJUSTMENT	35
	-	1	1	1	1	1	1752356-1	SUPPORT, TERMINAL	34
	-	2	2	2	2	2	2079383-5	SCR, BHSC, RoHS (M4 X 20)	33
	-	1	1	1	1	1	2161328-1	HEX HEAD, FLANGED, M5 X 8mm LONG	32
	-	1	1	1	1	1	1320908-2	SPACER, STRIP GUIDE	30
	-	1	1	1	1	1	2119959-1	ASSEMBLY, STRIP GUIDE	29
	-	1	1	1	1	1	1-455888-0	SPACER, CRIMPER	28
	-	1	1	1	1	1	1320928-2	STRIP GUIDE	24
	-	1	1	1	1	1	1-18028-2	WASHER, FLAT, REG M4	20
	-	1	1	1	1	1	2119806-1	INSERT, SHEAR	13
<sup>1</sup>	-	1	1	1	1	1	3-22280-3	SPRING, COMPRESSION	12
	-	1	1	1	1	1	1-356885-4	STOP, SHEAR	11
<sup>1</sup>	-	1	1	1	1	1	2119805-1	SHEAR HOLDER, FRONT	10
<sup>1</sup>	-	1	1	1	1	1	1803095-1	FLOATING SHEAR, FRONT	9
<sup>1</sup>	1	1	1	1	1	1	5-1333200-6	ANVIL, COMBINATION	8
	-	1	1	1	1	1	5-240641-4	SPACER	7
	-	-	-	-	-	-	-	-	6
	-	1	1	1	1	1	2119780-9	DEPRESSOR, SHEAR	5
	-	1	1	1	1	1	2-238011-2	BLOCK, CRIMPER SPACER	4
<sup>1</sup>	1	1	1	1	1	1	9-2119784-5	CRIMPER, INSULATION O PREMIUM	3
	-	-	-	-	-	-	-	-	2
<sup>1</sup>	1	1	1	1	1	1	1-456401-6	CRIMPER, WIRE .042 F PREMIUM	1
	-77	-7	-6	-5	-2	-1	PART NO	DESCRIPTION	ITEM NO

DIMENSIONS:		TOLERANCES UNLESS OTHERWISE SPECIFIED:		APPROVED:		NAME:	
mm	0 PLC ±	1 PLC ±	2 PLC ±	3 PLC ±	4 PLC ±	ANGLES ±	FINISH ±
MATERIAL:		WEIGHT:		SIZE:	CAGE CODE:	DRAWING NO:	RESTRICTED TO:
				A1	00779	©=2266553	
Customer Accessible Production Drawing				SCALE:	1:2	SHEET:	1 OF 4

LOC		DIST		REVISIONS			
A	66	P	LYN	DESCRIPTION	DATE	OWN	APVD
		-	-	SEE SHEET 1	-	-	-

### FEED TYPE MECHANICAL



### PNEUMATIC

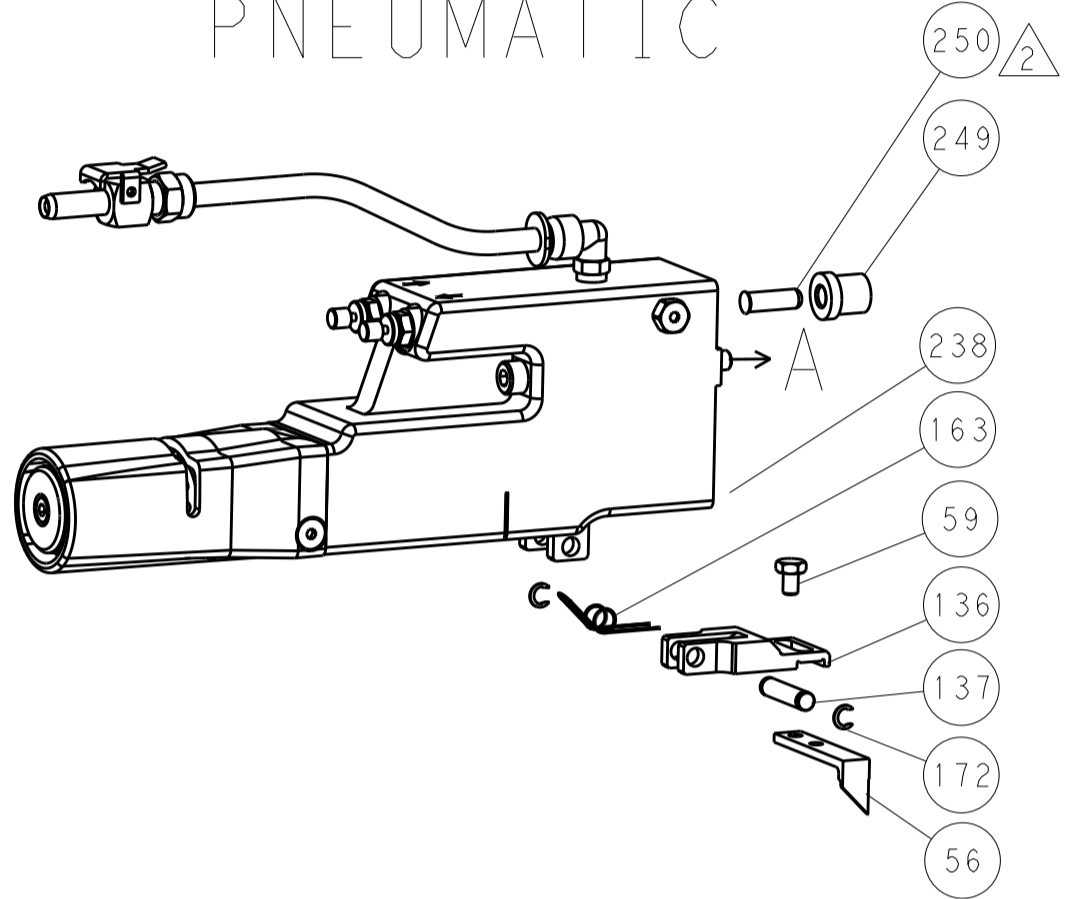

### SERVO LATCH PLATE



### CAM POSITIONS

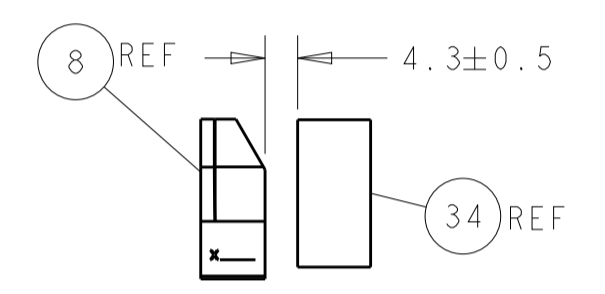
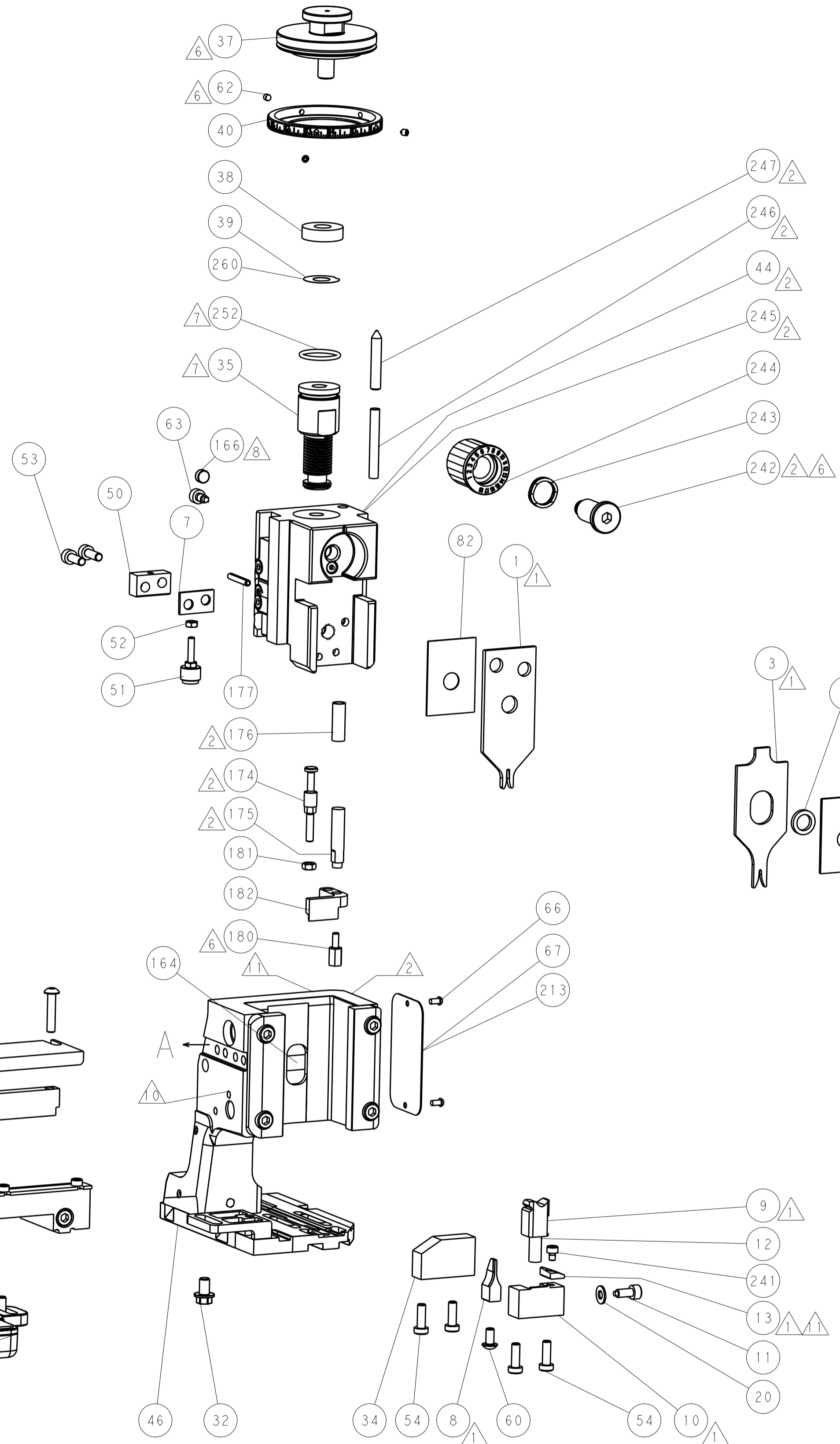
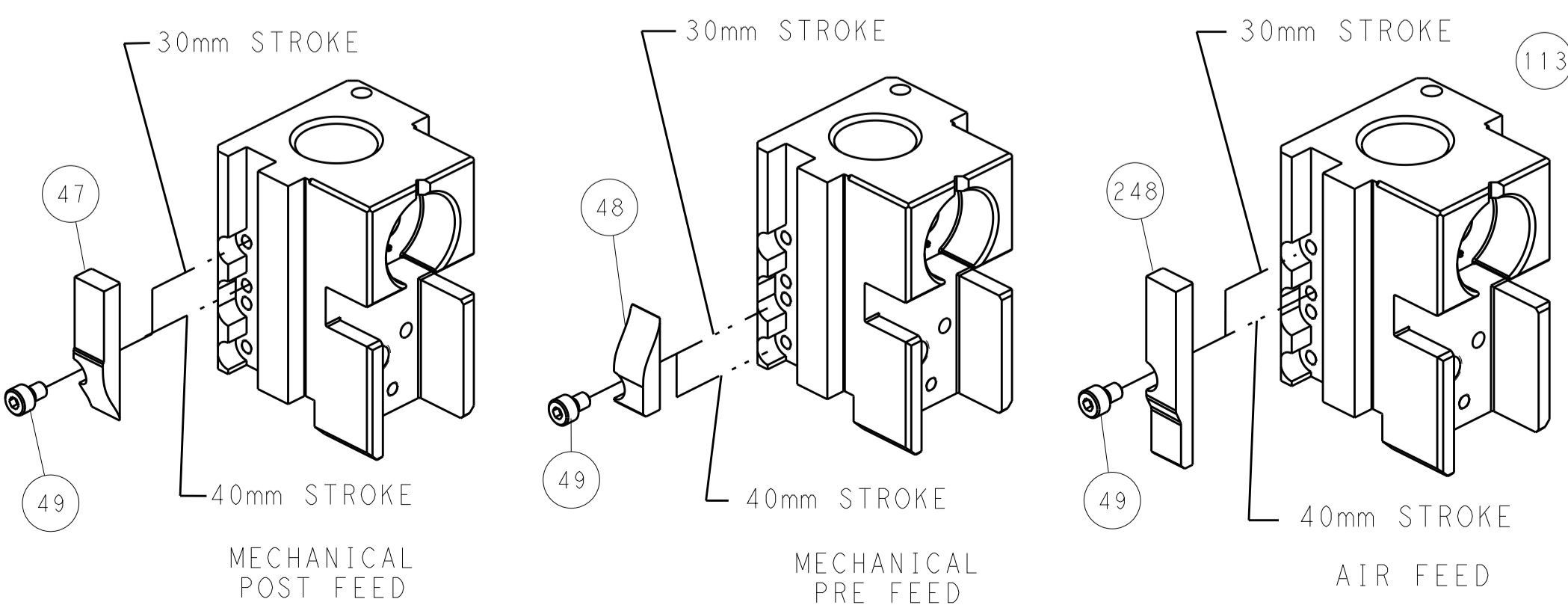

TERMINAL SUPPORT LOCATION

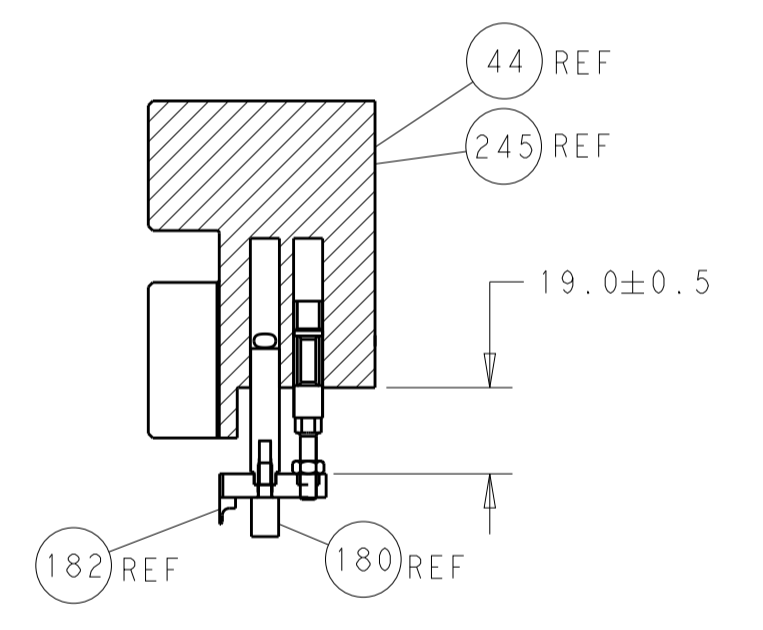

HOLDDOWN SET-UP

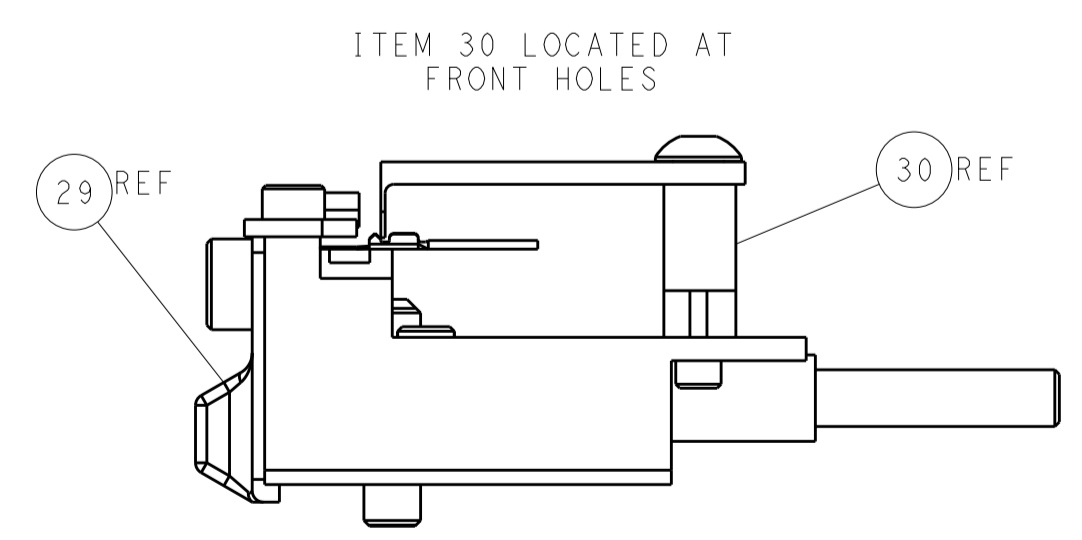

FEED TRACK POSITION GUIDE BY INSULATION BARREL

**ATLANTIC VERSION**  
 Shown on sheets 1 of 4 & 2 of 4  
 (Pacific version shown on sheets 3 of 4 & 4 of 4)

DIMENSIONS:		TOLERANCES UNLESS OTHERWISE SPECIFIED:		DWN BOB HIGMAN 20OCT2014		TE Connectivity	
mm	0 PLC ±0.5	1 PLC ±0.5	2 PLC ±0.13	3 PLC ±0.013	4 PLC ±0.001	APVD T. ELBIN 20OCT2014	Harrisburg, PA 17105-3608
MATERIAL:		FINISH:		NAME Ocean Side Feed Applicator		RESTRICTED TO	
Customer Accessible Production Drawing		SCALE 1:2		SIZE CAGE CODE DRAWING NO A11 00779 ©=2266553		SHEET 2 OF 4 REV C2	

PACIFIC VERSION TERMINATOR INTERFACE ADAPTER	PART NUMBER	REVISION	DESCRIPTION	FEED TYPE	
	2-2266553-1	C	FINE CRIMP HEIGHT ADJUST	MECHANICAL	OBSOLETE
	2-2266553-2	C	FINE CRIMP HEIGHT ADJUST	PNEUMATIC	OBSOLETE
	2-2266553-5	C	FINE CRIMP HEIGHT ADJUST	SERVO LATCH PLATE	OBSOLETE
	2-2266553-7	C	FINE CRIMP HEIGHT ADJUST	NONE	OBSOLETE
	7-2266553-7	A	CRIMP TOOLING KIT	-	

APPLICATOR DATA		
CRIMP WIRE	SIZE	TYPE
INSUL	1.07 mm [.042]	F
	1.22 mm [.048]	O
APPLICATOR INSTRUCTIONS 408-10389		

TERMINAL DATA: TE TERMINAL		TE CRIMP SPECIFICATION	
TERMINAL NAME: PIN & SOCKET SIZE 22 DF, AMPLIMITE			
WIRE STRIP LENGTH		INSULATION DIAMETER RANGE	
3.18-3.96 mm [1.25-.156 IN]		Ø0.76-1.02 mm [.030-.040 IN]	
TERMINAL APPLICATION SPECIFICATION	114-10001		
TERMINALS APPLIED			
TE TERMINAL	TE TERMINAL	TE TERMINAL	TE TERMINAL
1658670-1	748333-1	748610-1	1572142-1
1658670-3	748333-9	748610-8	1572143-1
1658670-6	1-748333-3	1658686-1	
1658686-3	1658686-5		

WIRE SIZE	CRIMP HEIGHT mm [INCH]	CRIMP HEIGHT REFERENCE SETTING
22 AWG	0.86+/-0.03 [.034+/-0.001]	7.7
24 AWG	0.76+/-0.03 [.030+/-0.001]	9.4
26 AWG	0.69+/-0.03 [.027+/-0.001]	9.8
28 AWG	0.64+/-0.03 [.025+/-0.001]	10.3

- RECOMMENDED SPARE PARTS
- GREASE BEARING SURFACES LIGHTLY
- LUBRICATE DAILY PER THE APPLICATOR INSTRUCTION SHEET SUPPLIED WITH THE APPLICATOR.
- APPLICATOR SPECIFIC DATA TO BE ENTERED INTO BLANK MEMORY CHIP AT ASSEMBLY. SEE BELOW FOR PART NUMBER:  
 MECHANICAL FEED WITH "SMART APPLICATOR" CONVERSION: 8-2266553-4  
 PNEUMATIC FEED WITH "SMART APPLICATOR" CONVERSION: 8-2266553-4  
 SERVO FEED WITH "FINE CRIMP HEIGHT ADJUST": 8-2266553-5
- ADJUSTMENT OF THE STRIPPER MAY BE REQUIRED WHEN MOVING THE APPLICATOR BETWEEN BENCH AND LEADMAKER APPLICATIONS.
- APPLY PART NUMBER 1-23419-5 LOCTITE TO THREADS OF ITEM 62 & 180. APPLY PART NUMBER 2-23419-6 LOCTITE TO THREADS OF ITEM 242.
- GREASE THREADS, GROOVE AND O-RING ON ITEMS 139 & 152.
- MAGNET MUST BE ORIENTED CORRECTLY IN ORDER TO PROPERLY ACTUATE THE COUNTER.
- CRIMP HEIGHT REFERENCE SETTING WAS THE SETTING USED WHEN THE APPLICATOR WAS QUALIFIED AT THE FACTORY. ADJUSTMENT MAY BE NECESSARY WHEN RUNNING APPLICATOR IN THE FIELD.
- SPARE FEED CAM STORAGE LOCATION REFER TO INSTRUCTION SHEET FOR ADDITIONAL INFORMATION.
- TO CONVERT THE APPLICATOR TO A NON-CARRIER CUTTING STYLE, REMOVE ITEM 13 AND ATTACH TO THE LOCATION ON BACK SIDE OF THE HOUSING. REFER TO INSTRUCTION SHEET FOR ADDITIONAL INFORMATION.
- THIS APPLICATOR IS SPECIFIC FOR USE IN A STRIPPER SEAL TERMINATING UNIT.
- TERMINAL LUBRICANT IS RECOMMENDED.

**\*WARNING**  
 ON INSTALLATION, SET WIRE DISC, ITEM 40 TO LARGEST WIRE SIZE SETTING. USE OF SETTINGS BELOW MINIMUM REQUIRED CRIMP HEIGHT SETTING WILL CAUSE DAMAGE TO CRIMP TOOLING.

-	1	1	1	1	2119782-1	FINE ADJUST HEAD ASM, PACIFIC STYLE	251
-	-	-	1	-	2119640-1	PUSH ROD, AIR FEED	250
-	-	-	1	-	2079988-1	BUSHING, LCH5-12, MISUMI	249
-	1	1	1	1	1-22279-3	SPRING, COMPRESSION	246
-	1	1	1	1	2119082-5	CAM, SNAIL, INSULATION ADJUSTMENT	244
-	1	1	1	1	2079764-1	WASHER, WAVE SPRING, CREST-TO-CREST	243
-	1	1	1	1	2119083-1	RETAINER, INSULATION DIAL	242
-	1	1	1	1	7-18023-7	SCR, SKT HD CAP M3 X 4.0	241
-77	-27	-25	-22	-21	PART NO	DESCRIPTION	ITEM NO

**PACIFIC VERSION**  
 Shown on sheets 3 of 4 & 4 of 4  
 (Atlantic version shown on sheets 1 of 4 & 2 of 4)

SET UP GAUGE	LOC	DIST	REVISIONS			
2119599-1	A	66	REV	DATE	BY	APPV
			-	SEE SHEET 1		

-	-	2	-	-	2168400-6	SHCS, LOW HEAD, RoHS, M5 X 16	240	
-	-	-	-	1	2119580-1	MECHANICAL FEED ASSEMBLY	239	
-	-	-	-	1	2063440-1	AIR FEED MODULE	238	
-	-	-	-	1	2119740-2	TAG, IDENTIFICATION	213	
-	-	-	-	1	1901094-3	SPACER, FEEDER	198	
-	1	1	1	1	4-1722335-3	STRIPPER, SIDE FEED	182	
-	1	1	1	1	1-5018030-0	NUT, HEX, REG, RoHS, M3.5	181	
-	1	1	1	1	1-1752354-9	STANDOFF, HOLD-DOWN	180	
-	1	1	1	1	993111-1	PIN, SLOTTED SPRING 3.0 X 20.0	177	
-	1	1	1	1	5-22280-0	SPRING, COMPRESSION	176	
-	1	1	1	1	1752353-3	GUIDE PIN, HOLDDOWN	175	
-	1	1	1	1	1901680-2	GUIDE PIN, HOLDDOWN	174	
-	-	-	-	2	21045-3	RING, RETAIN, EXTERN, 3/16 CRESCENT	172	
-	1	1	1	1	994969-1	MAGNET, RARE EARTH HIGH ENERGY	166	
-	REF	REF	REF	REF	994970-2	COUNTER, MAGNETIC	164	
-	-	-	-	1	240638-1	SPRING, FEED FINGER	163	
-	1	1	1	1	8-21084-1	O-RING, .801 ID, .070 DIA. MAT.	152	
-	-	-	-	1	2119641-2	FEED CAM, AIR FEED	151	
-	1	1	1	1	2119798-2	DETENT PIN	145	
-	1	1	1	1	2079383-8	SCR, BHSC, RoHS (M4 X 16)	144	
-	4	4	4	4	2168400-5	SHCS, LOW HEAD, RoHS, M4 X 20	143	
-	-	-	-	1	2119653-2	FEED CAM, POST FEED	142	
-	1	1	1	1	2-2119656-2	APPLICATOR BASIC ASSEMBLY, SF	141	
-	1	1	1	1	2119650-1	RAM, ASIAN STYLE, SIDE FEED	140	
-	1	1	1	1	2119092-2	BOLT, ADJUSTMENT	139	
-	-	-	-	1	3-23627-7	PIN, RETAIN, GRVD, 3/16 X .854	137	
-	-	-	-	1	2119799-1	HOLDER, FEED FINGER, AF	136	
-	-	REF	-	-	-	SEE NOTE 4	MEMORY CHIP, PROGRAMMED	135
-	-	-	-	1	1633743-1	SERVO FEED LATCH ASM	133	
-	-	REF	-	-	-	2119944-1	FEED FINGER ASSEMBLY, SF	117
-	1	1	1	1	2119955-1	ASSY, LUBRICATOR, SIDE FEED	113	
-	1	1	1	1	455888-5	SPACER, CRIMPER	82	
-	1	1	1	1	5-547505-2	SPRING, COMPRESSION	77	
-	1	1	1	1	854769-4	HOLDER, INS	74	
-	1	1	1	1	2119956-1	DOCUMENTATION PACKAGE	71	
-	1	-	-	1	2119740-1	TAG, IDENTIFICATION	67	
-	2	2	2	2	2168078-1	SCREW, DRIVE, RH, RoHS, 2 x .188	66	
-	1	1	1	1	2119793-1	LIMITER, ADJUSTMENT BOLT	63	
-	3	3	3	3	992763-5	SCR, SET, SOC, CONE PNT, M3 X 4.0	62	
-	-	-	-	1	5-18022-5	SCR, HEX HD CAP, M4 X 6.0	59	
-	1	1	1	1	21028-2	PIN, SLOTTED SPRING .062 X .250	58	
-	-	-	-	1	1338685-1	PAWL, FEED	56	
-	2	2	2	2	2168083-3	SCR, SKT HD CAP, RoHS, M4 X 12.0	53	
-	1	1	1	1	5018030-1	NUT, HEX, REG, RoHS, M3	52	
-	1	1	1	1	811242-5	BUMPER, HOLD DOWN	51	
-	1	1	1	1	690753-2	SPACER, TONKER	50	
-	-	-	-	1	2	18023-9	SCR, SKT HD CAP M4 X 6.0	49
-	-	-	-	1	2119652-1	FEED CAM, PRE FEED	48	
-	1	1	1	1	2079383-7	SCR, BHSC, RoHS (M8 X 25)	41	
-	1	1	1	1	2119645-1	DISC, NUMBERED FA WIRE ADJUSTMENT	40	
-	1	1	1	1	2119957-1	APPLICATOR SHIM PACK	39	
-	1	1	1	1	2119644-1	RAM WASHER, PRECISION	38	
-	1	1	1	1	1752356-1	SUPPORT, TERMINAL	34	
-	2	2	2	2	2079383-5	SCR, BHSC, RoHS (M4 X 20)	33	
-	1	1	1	1	2161328-1	HEX HEAD, FLANGED, M5 X 8mm LONG	32	
-	1	1	1	1	1320908-2	SPACER, STRIP GUIDE	30	
-	1	1	1	1	2119959-1	ASSEMBLY, STRIP GUIDE	29	
-	1	1	1	1	1-455888-0	SPACER, CRIMPER	28	
-	1	1	1	1	1320928-2	STRIP GUIDE	24	
-	1	1	1	1	1-18028-2	WASHER, FLAT, REG M4	20	
-	1	1	1	1	2119806-1	INSERT, SHEAR	13	
-	1	1	1	1	3-22280-3	SPRING, COMPRESSION	12	
-	1	1	1	1	1-356885-4	STOP, SHEAR	11	
-	1	1	1	1	2119805-1	SHEAR HOLDER, FRONT	10	
-	1	1	1	1	1803095-1	FLOATING SHEAR, FRONT	9	
-	1	1	1	1	5-1333200-6	ANVIL, COMBINATION	8	
-	1	1	1	1	5-240641-4	SPACER	7	
-	-	-	-	-	-	-	6	
-	1	1	1	1	2119780-9	DEPRESSOR, SHEAR	5	
-	1	1	1	1	2-238011-2	BLOCK, CRIMPER SPACER	4	
-	1	1	1	1	9-2119784-5	CRIMPER, INSULATION O PREMIUM	3	
-	-	-	-	-	-	-	2	
-	1	1	1	1	1-456401-6	CRIMPER, WIRE .042 F PREMIUM	1	
-77	-27	-25	-22	-21	PART NO	DESCRIPTION	ITEM NO	

DIMENSIONS:		TOLERANCES UNLESS OTHERWISE SPECIFIED:		DRAWING NO	
mm	0 PLC ±.5	1 PLC ±0.5	2 PLC ±0.13	3 PLC ±0.013	4 PLC ±0.001
	ANGLES ±.0001				
MATERIAL	FINISH	WEIGHT	SCALE	SHEET	REV
			1:2	3 OF 4	C2

LOC		DIST		REVISIONS			
A	66	P	LTM	DESCRIPTION	DATE	OWN	APVD
		-	-	SEE SHEET 1	-	-	-

# FEED TYPE MECHANICAL

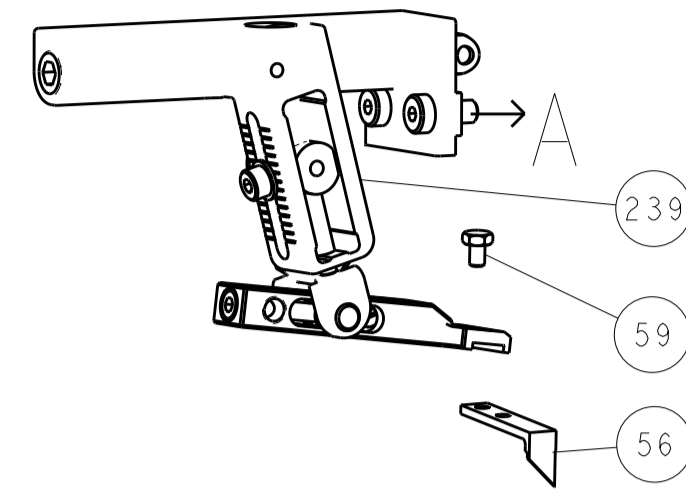

# PNEUMATIC

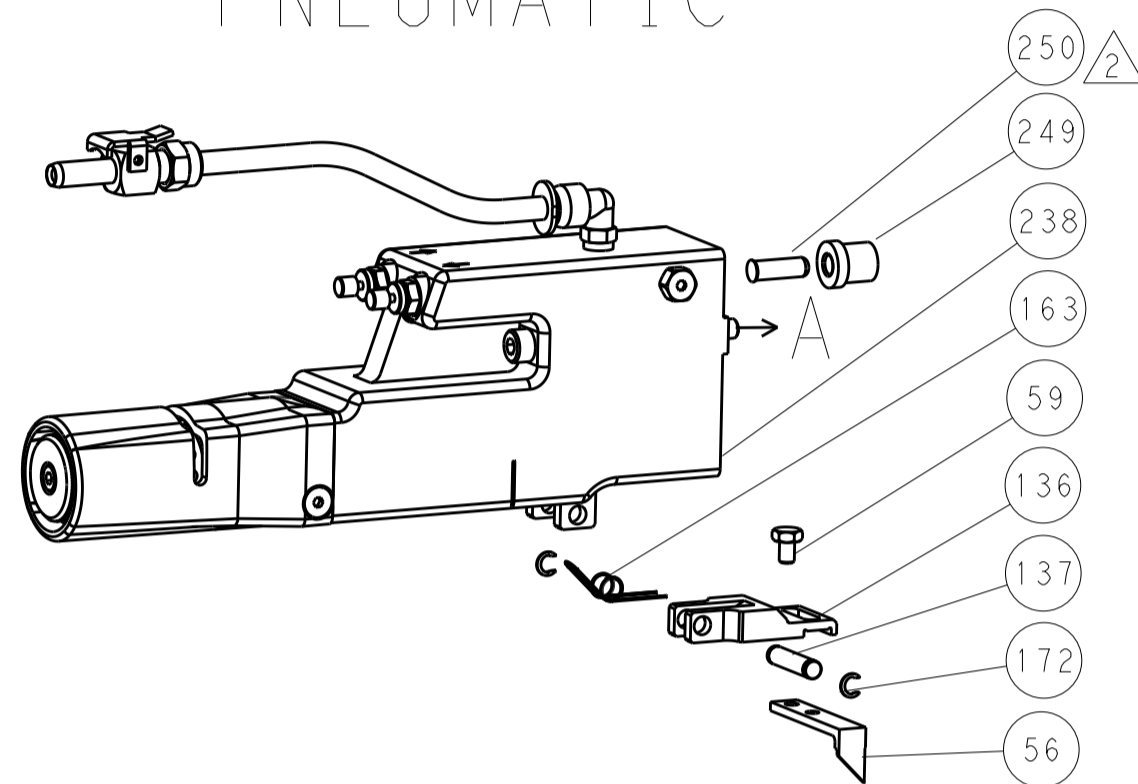

# SERVO LATCH PLATE

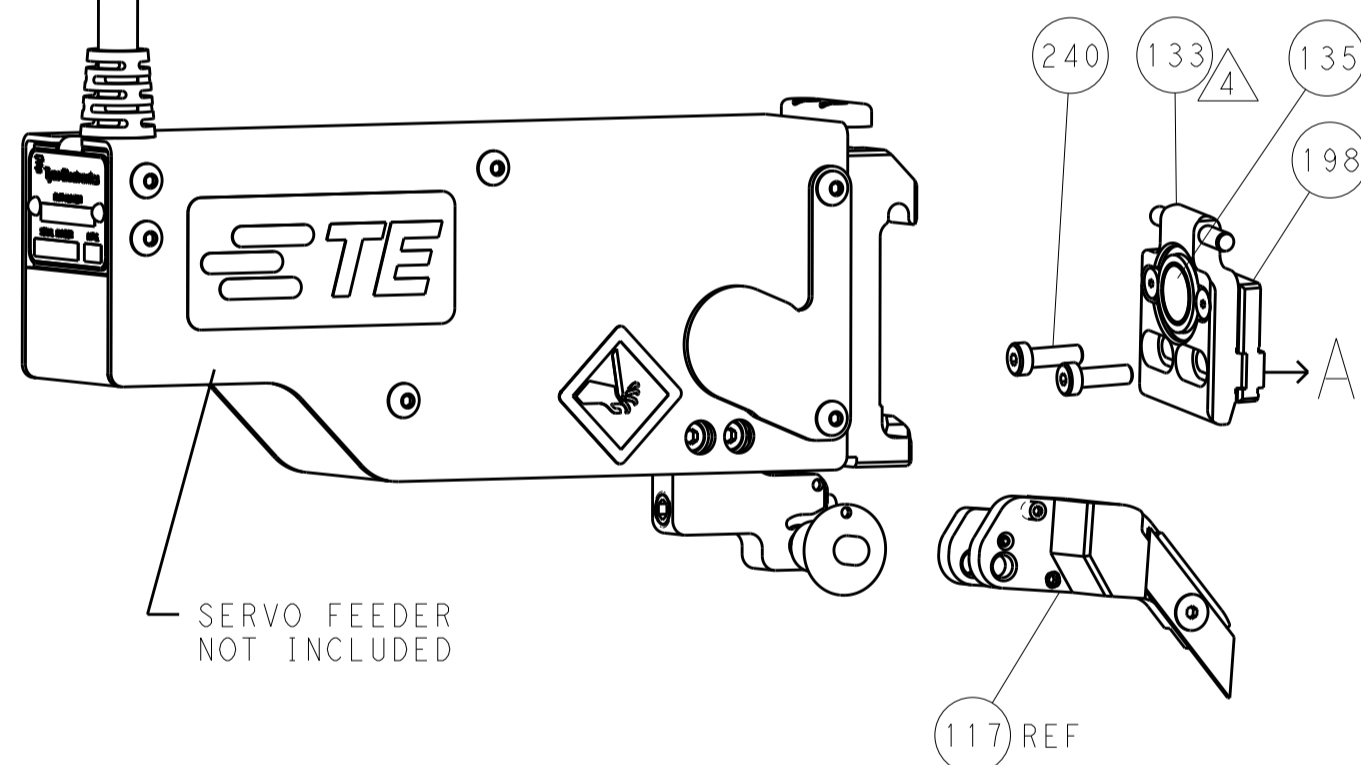

# CAM POSITIONS

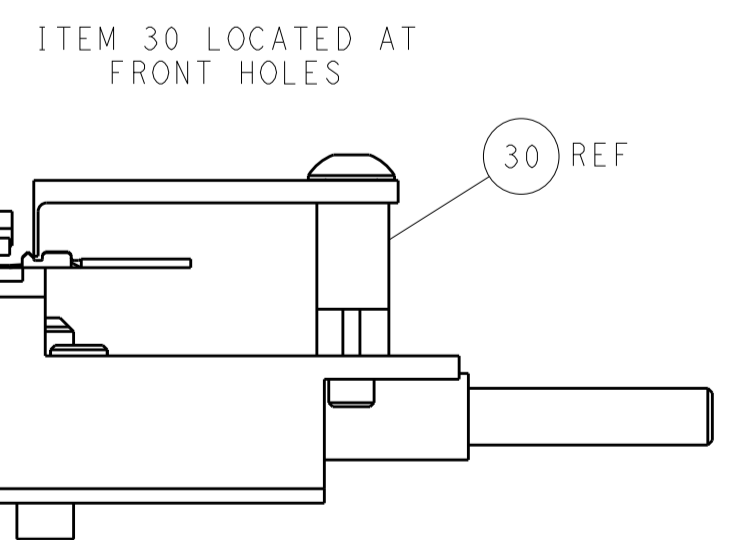
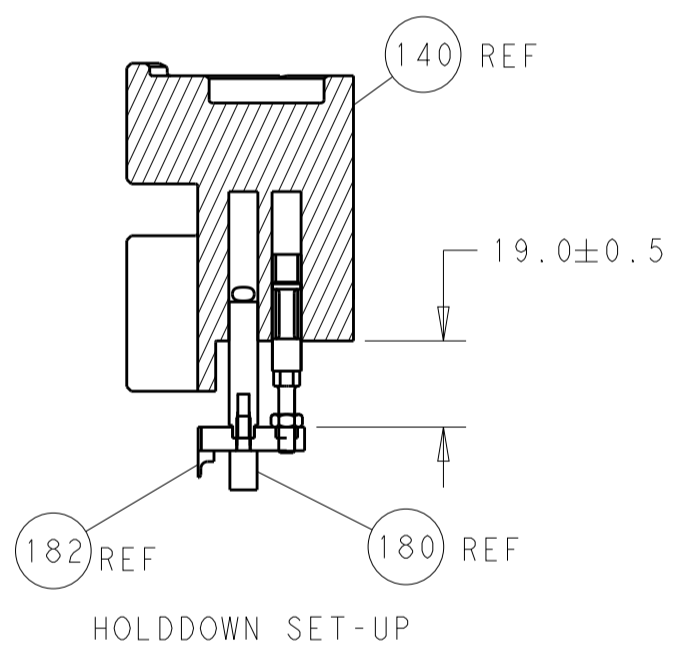
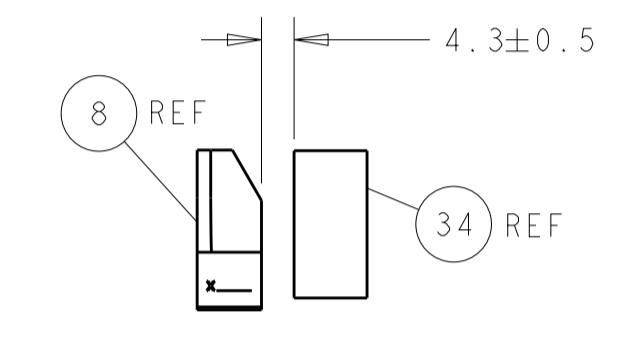
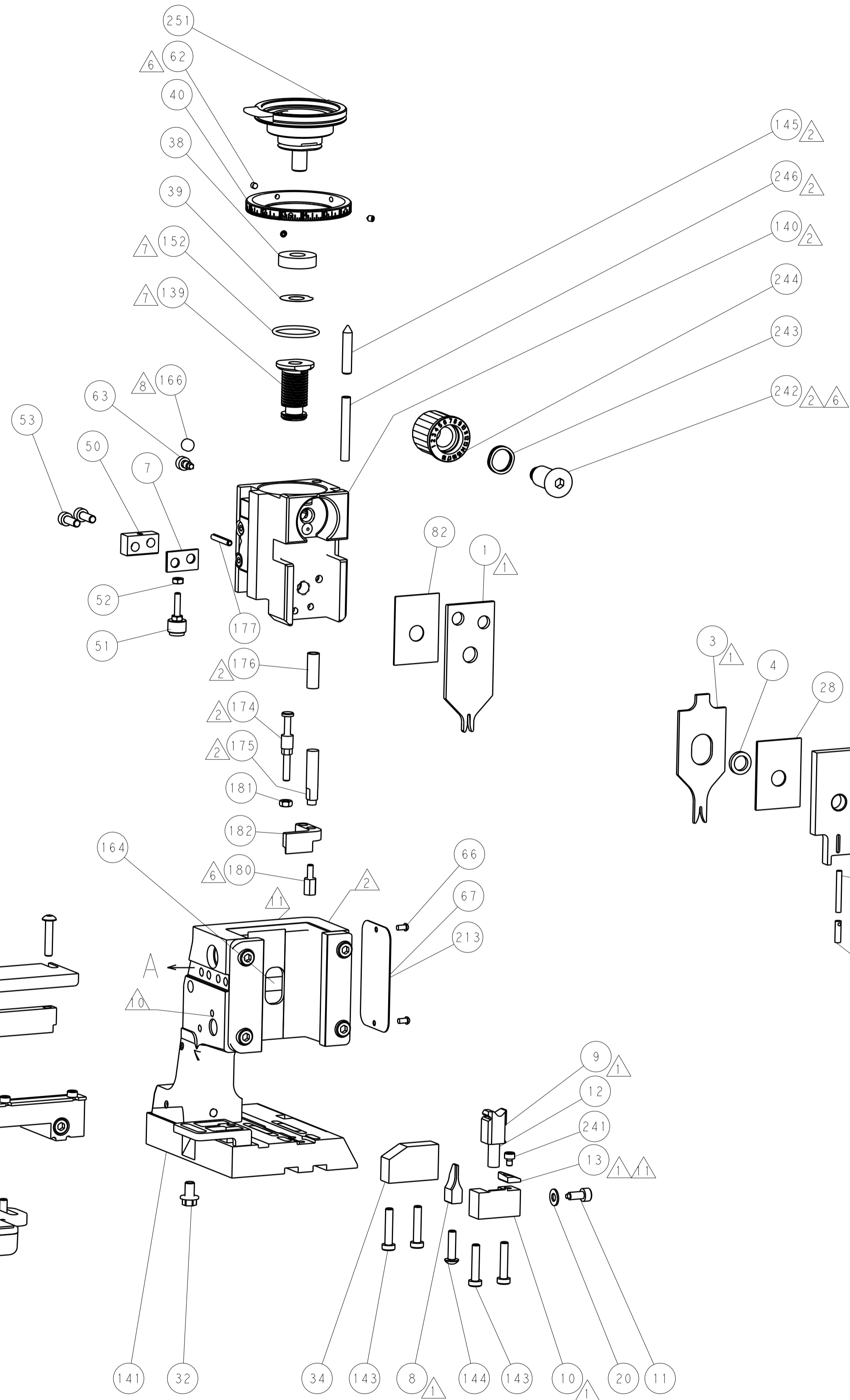
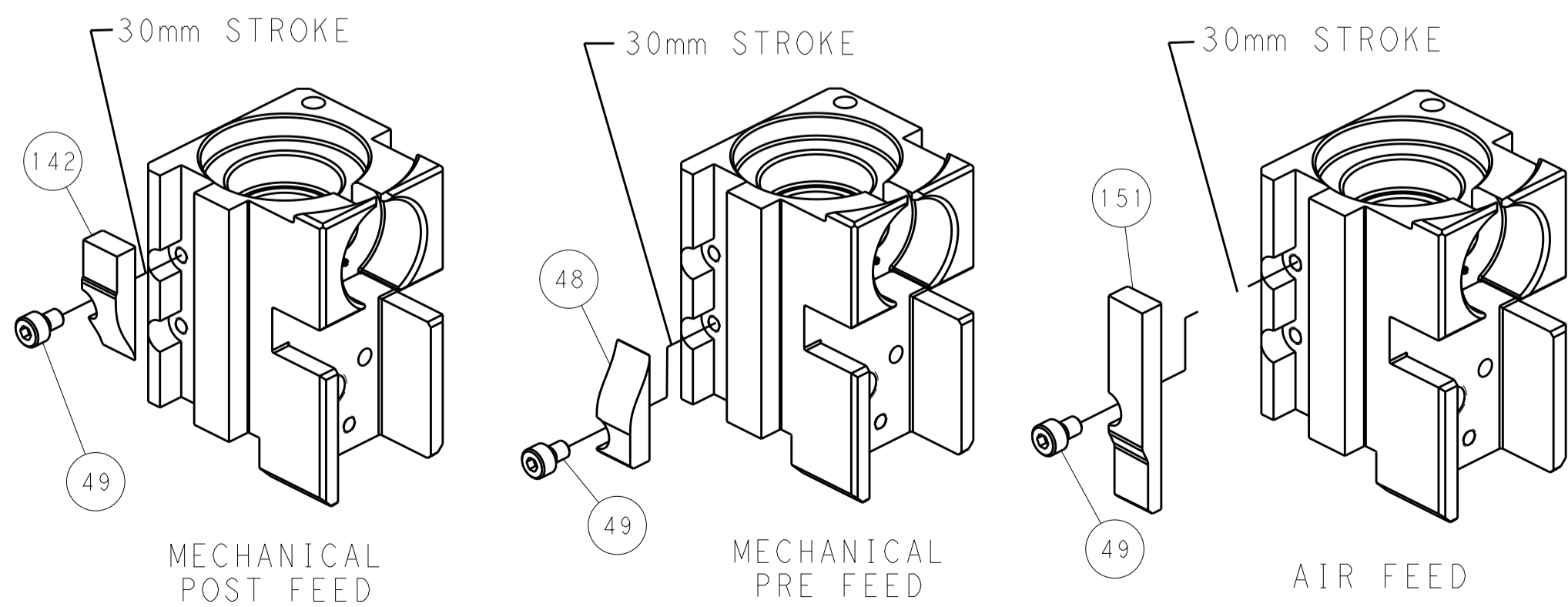

**PACIFIC VERSION**  
 Shown on sheets 3 of 4 & 4 of 4  
 (Atlantic version shown on sheets 1 of 4 & 2 of 4)

DIMENSIONS:		TOLERANCES UNLESS OTHERWISE SPECIFIED:		DWG: BOB_HIGMAN 20OCT2014		TE Connectivity	
mm	0 PLC ±0.5	1 PLC ±0.5	2 PLC ±0.13	3 PLC ±0.013	4 PLC ±0.001	APVD: T.ELBIN 20OCT2014	Harrisburg, PA 17105-3608
MATERIAL:		FINISH:		NAME: Ocean Side Feed Applicator		RESTRICTED TO:	
Customer Accessible Production Drawing		SCALE: 1:2		SIZE: A1		CAGE CODE: 00779	
				DRAWING NO: C-2266553		SHEET 4 OF 4	
				REV: C2			