



FEATURES:

- Wide 4:1 Input Voltage Range
- High efficiency up to 91%
- 1500 VDC Isolation
- Over Current Protection
- Remote On/Off control
- Operating Temperature -40°C to +105°C
- Output Over Voltage protection
- Continuous Short Circuit Protection
- Input Under Voltage Protection
- Bare Part Meet CISPR32/EN55032 Class A



Models
Single output

Model	Input Voltage (VDC)	Output Voltage (VDC)	Input Current max Full/No Load (mA)	Output Current max (mA)	Isolation (VDC)	Max Capacitive Load (uF)	Efficiency Typ. (%)
AM15CW-2403S-NZ	9-36	3.3	640/50	4000	1500	4700	88
AM15CW-2405S-NZ	9-36	5	710/50	3000	1500	4700	90
AM15CW-2412S-NZ	9-36	12	710/15	1250	1500	1000	90
AM15CW-2415S-NZ	9-36	15	703/15	1000	1500	820	91
AM15CW-2424S-NZ	9-36	24	703/20	625	1500	270	91
AM15CW-4803S-NZ	18-75	3.3	320/30	4000	1500	4700	88
AM15CW-4805S-NZ	18-75	5	356/30	3000	1500	4700	90
AM15CW-4812S-NZ	18-75	12	352/11	1250	1500	1000	91
AM15CW-4815S-NZ	18-75	15	352/11	1000	1500	820	91
AM15CW-4824S-NZ	18-75	24	352/11	625	1500	270	91

*Add suffix “-ST” for optional screw terminal bottom plate or “-STD” for optional DIN Rail screw terminal bottom plate.

**Add suffix “-K” for optional heatsink, “-K-ST” for optional heatsink and screw terminal bottom plate or “-K-STD” for optional heatsink and DIN Rail screw terminal bottom plate.

Models
Dual output

Model	Input Voltage (VDC)	Output Voltage (VDC)	Input Current max Full/No Load (mA)	Output Current max (mA)	Isolation (VDC)	Max Capacitive Load (uF)	Efficiency Typ. (%)
AM15CW-2405D-NZ✘	9-36	± 5	710/50	± 1500	1500	± 1500	87
AM15CW-2412D-NZ✘	9-36	± 12	710/15	± 625	1500	± 470	90
AM15CW-2415D-NZ✘	9-36	± 15	703/15	± 500	1500	± 330	90
AM15CW-2424D-NZ✘	9-36	± 24	703/20	± 312	1500	± 200	89
AM15CW-4805D-NZ✘	18-75	± 5	356/30	± 1500	1500	± 1500	86
AM15CW-4812D-NZ✘	18-75	± 12	352/11	± 625	1500	± 470	90
AM15CW-4815D-NZ✘	18-75	± 15	352/11	± 500	1500	± 330	90
AM15CW-4824D-NZ✘	18-75	± 24	352/11	± 312	1500	± 200	90

*Add suffix “-ST” for optional screw terminal bottom plate or “-STD” for optional DIN Rail screw terminal bottom plate.

NOTE: All specifications in this datasheet are measured at an ambient temperature of 25°C, humidity<75%, nominal input voltage and at rated output load unless otherwise specified.

Input Specifications

Parameters	Nominal	Typical	Maximum	Units
Voltage range	24 Vin	9-36		VDC
	48 Vin	18-75		
Filter		Pi		
Absolute Maximum Rating (1s)	24 Vin		-0.7 – 50	VDC
	48 Vin		-0.7 – 100	
Input reflected ripple current	Nominal input,	30		mA
Input Under voltage protection	24 Vin	6.5		VDC
	48 Vin	15.5		
Startup time	Nominal input, resistive load	10		ms
Remote On/Off Control	On Off		3.5-12VDC or leave open 0-1.2VDC or connect to GND, idle current 2-7mA	

Isolation Specifications

Parameters	Conditions	Typical	Maximum	Units
Tested I/O voltage	60 sec, <1mA	1500		VDC
Resistance	500VDC	>1000		MOhm
Capacitance	I/O, 100KHz/0.1V	2000		pF

Output Specifications

Parameters	Conditions	Typical	Maximum	Units	
Voltage accuracy	0% to 100% load	±1	±3	%	
Over voltage protection		110-160		% of Vout	
Over current protection	Single output	110-190		% of Iout	
	Dual output	110-270			
Short Circuit protection	Continuous				
Short circuit restart	Auto-Recovery				
Line voltage regulation	Full load, LL to HL , Positive output	±0.2	±0.5	% of Vin	
	Full load, LL to HL , Negative output	±0.4	±1		
Load voltage regulation	5% to 100% load	±0.5	±1	%	
Cross Regulation	Dual output , main circuit with 50% load, auxiliary circuit with 10%-100% load		±5	%	
Temperature coefficient	100% load		±0.03	%/°C	
Ripple & Noise	20MHz Bandwidth, 5-100% load	Single output	50	100	mV p-p
		Dual output	100	200	
Transient recovery time	25% load step change	0.3	0.5	ms	
Transient recovery deviation	25% load step change	3.3/5V output	±3	±8	%
		Others	±3	±5	

General Specifications

Parameters	Conditions	Typical	Maximum	Units
Switching frequency	100% load	Single 3.3/5V output	300	KHz
		Others	270	
Operating temperature	See derating curve	Single 3.3/5V output	-40 to +95	°C
		Others	-40 to +105	
Storage temperature		-55 to +125		°C
Cooling	Free air convection			
Humidity			95	% RH
Case material	Aluminum Alloy			
Weight	Pin mountable	15		g
	With optional -ST mounting plate:	38		
	With optional -STD mounting plate:	58		
	With optional -K Pin mountable	20		
	With optional -ST-K mounting plate:	42		
	With optional -STD-K mounting plate:	62		
Dimensions (L x W x H)	Pin mountable	1 x 1 x 0.46 inches	25.40 x 25.40 x 11.70 mm	
	With optional -ST mounting plate:	2.99 x 1.24 x 0.84 inches	76.00 x 31.50 x 21.20 mm	
	With optional -STD mounting plate:	2.99 x 1.24 x 1.02 inches	76.00 x 31.50 x 25.80 mm	
	With optional -K Pin mountable	1 x 1 x 0.64 inches	25.40 x 25.40 x 16.20 mm	
	With optional -ST-K mounting plate:	2.99 x 1.24 x 0.99 inches	76.00 x 31.50 x 25.20 mm	
	With optional -STD-K mounting plate:	2.99 x 1.24 x 1.17 inches	76.00 x 31.50 x 29.80 mm	
MTBF	>1,000,000 hours (MIL-HDBK -217F, Ground Benign, t=+25°C)			
Maximum soldering temperature	1.5mm from case for 10 sec		300	°C

Safety Specifications

Parameters	
Agency approvals	CE EN62368-1; cULus UL62368-1 (✗ with exception of dual output models)
	CISPR32 / EN 55032, Class A / Class B with the recommended EMC circuit
Information technology Equipment	Designed to meet IEC62368-1
Electrostatic Discharge Immunity	IEC 61000-4-2, Contact ±6KV, Air ±8KV, Criteria B
RF, Electromagnetic Field Immunity	IEC 61000-4-3, 10V/m, Criteria A
Electrical Fast Transient / Burst Immunity	IEC 61000-4-4, ±2KV with the recommended EMC circuit, Criteria A

Surge Immunity	IEC 61000-4-5, L-L ±2KV with the recommended EMC circuit, Criteria B
RF, Conducted Disturbance Immunity	IEC 61000-4-6, 3 Vrms, Criteria A

Dimensions

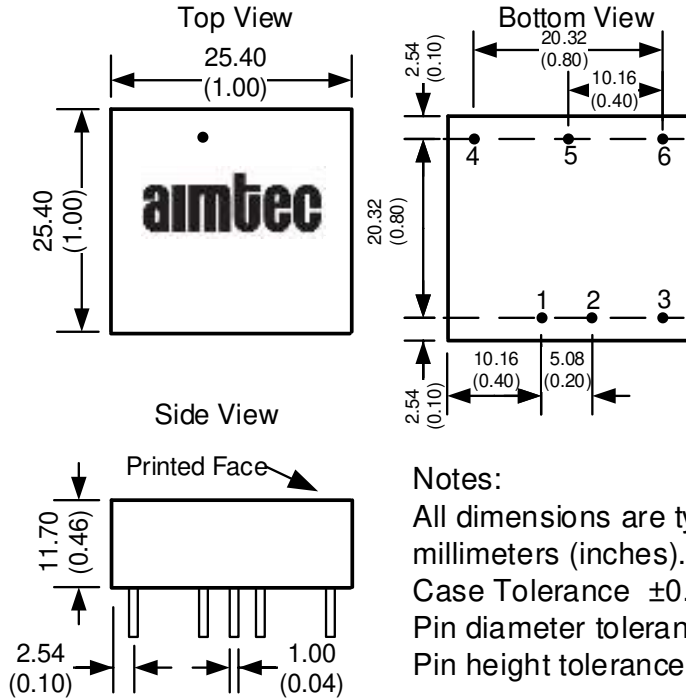

Notes:

- All dimensions are typical in millimeters (inches).
- Case Tolerance ± 0.25 (± 0.01)
- Pin diameter tolerance ± 0.1 (± 0.004)
- Pin height tolerance ± 0.5 (± 0.02)

Pin Out Specifications

Pin	Single	Dual
1	+V Input	+V Input
2	-V Input	-V Input
3	On/Off Control	On/Off Control
4	+V Output	+V Output
5	Trim	Common
6	-V Output	-V Output

Heatsink Option: AM15CW-NZ-K

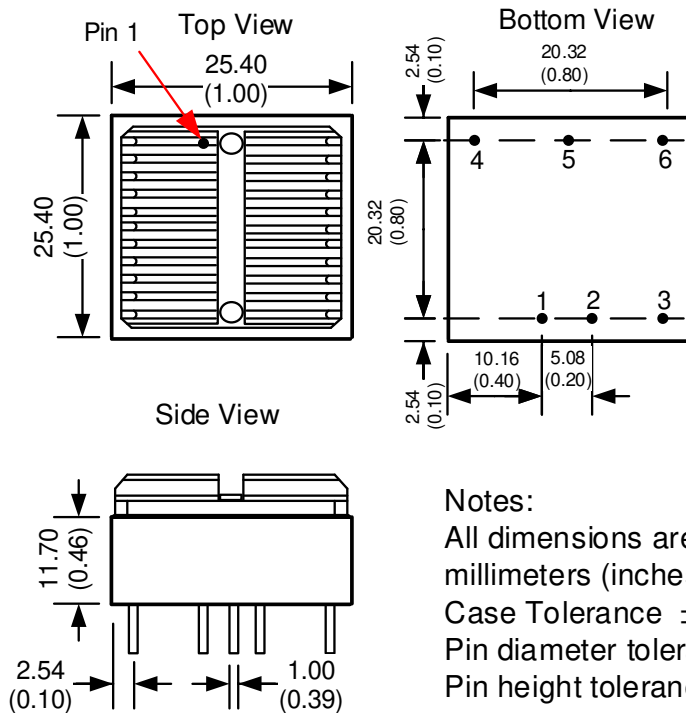

Notes:

- All dimensions are typical in millimeters (inches).
- Case Tolerance ± 0.25 (± 0.01)
- Pin diameter tolerance ± 0.1 (± 0.004)
- Pin height tolerance ± 0.5 (± 0.02)

Screw Terminal Option: AM15CW-NZ-ST

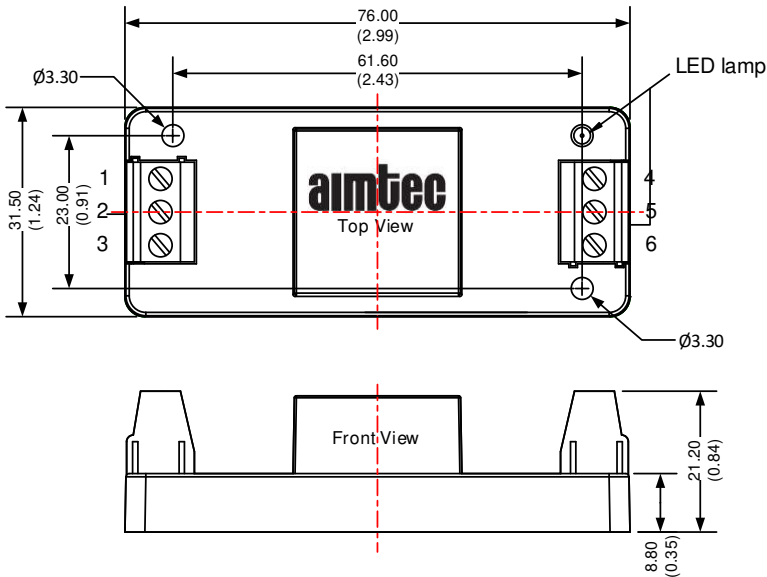

Pin Out Specifications

Pin	Single	Dual
1	On/off Ctrl	On/off Ctrl
2	-V Input	-V Input
3	+V Input	+V Input
4	-V Output	-V Output
5	Trim	Common
6	+V Output	+V Output

Note:
Unit: mm (inch)
Wire range: 24-12 AWG
Tightening torque: Max 0.4 N*m
General tolerances: ±0.50 (±0.02)

Screw Terminal with heatsink Option: AM15CW-NZ-K-ST

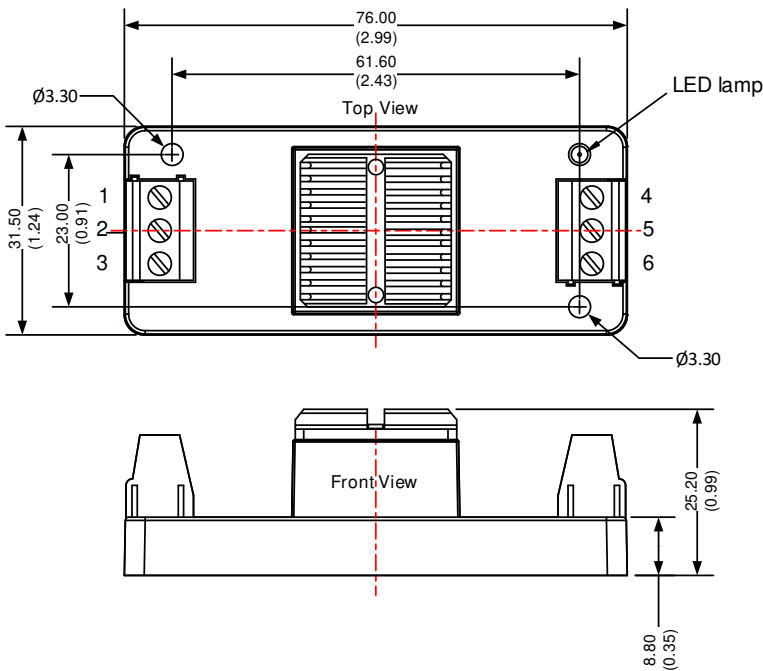

Note:
Unit: mm (inch)
Wire range: 24-12 AWG
Tightening torque: Max 0.4 N*m
General tolerances: ±0.50 (±0.02)

DIN-RAIL Option: AM15CW-NZ-STD

Pin Out Specifications

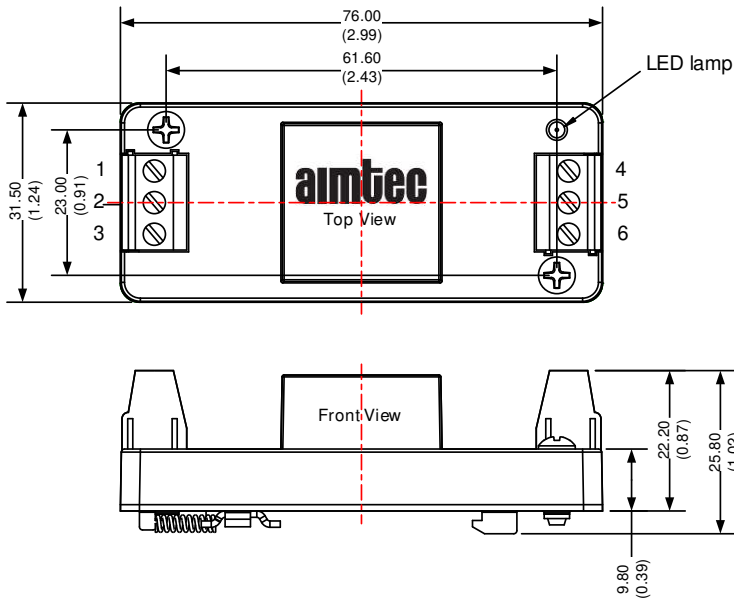

Pin	Single	Dual
1	On/off Ctrl	On/off Ctrl
2	-V Input	-V Input
3	+V Input	+V Input
4	-V Output	-V Output
5	Trim	Common
6	+V Output	+V Output

Note:
Unit: mm (inch)
Mounting rail: TS35
Wire range: 24-12 AWG
Tightening torque: Max 0.4 N*m
General tolerances: ± 0.50 (± 0.02)

DIN-RAIL with heatsink Option: AM15CW-NZ-K-STD

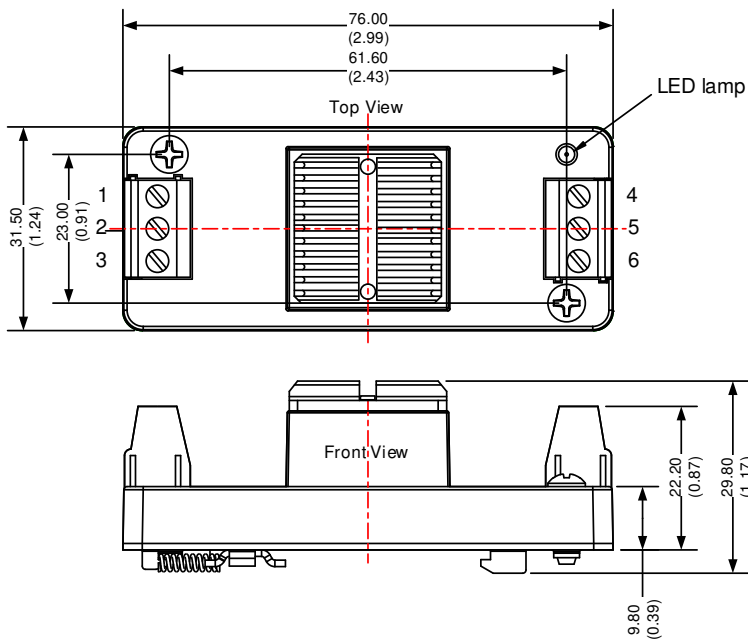

Note:
Unit: mm (inch)
Mounting rail: TS35
Wire range: 24-12 AWG
Tightening torque: Max 0.4 N*m
General tolerances: ± 0.50 (± 0.02)

Derating

Single output

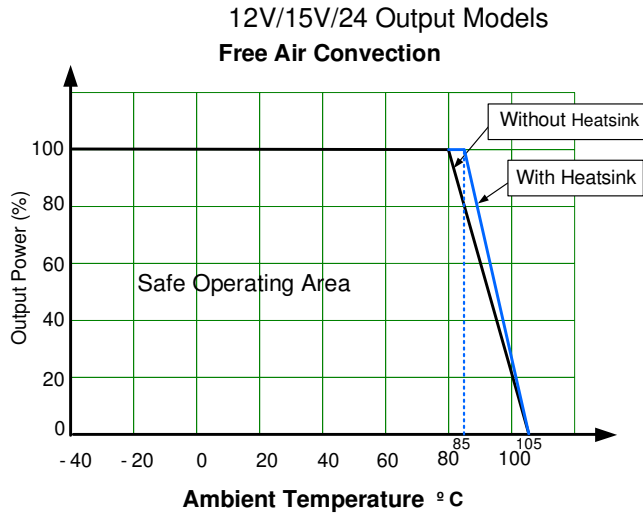
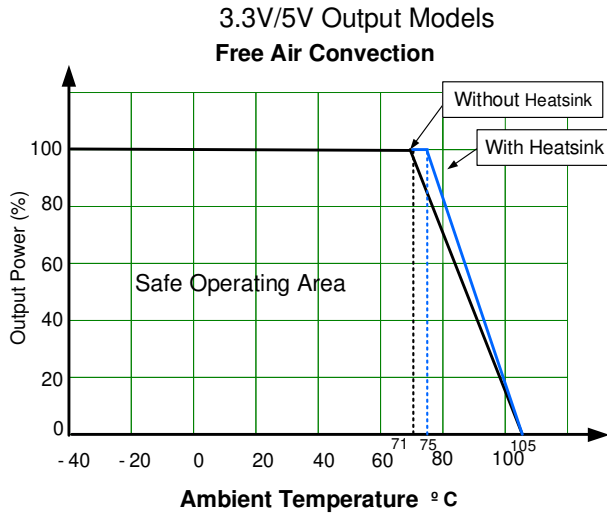

Dual output

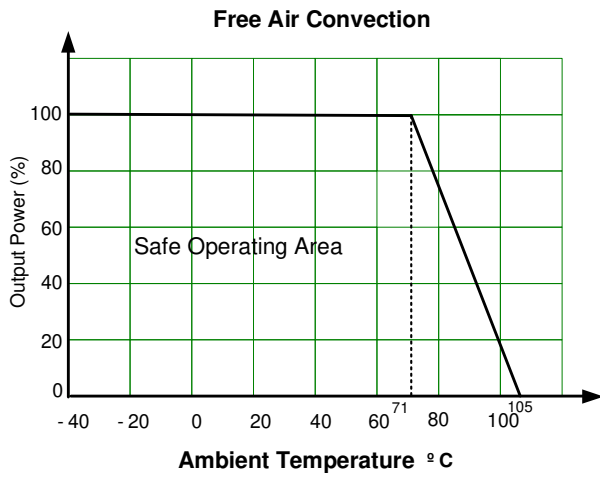

Typical Application Circuits

Single output

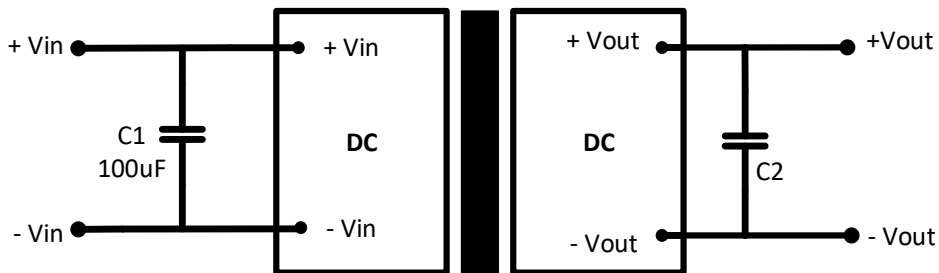

Model	3.3V/5V/12V/15V Vout	24V Vout
C2	100µF	47µF

Dual output

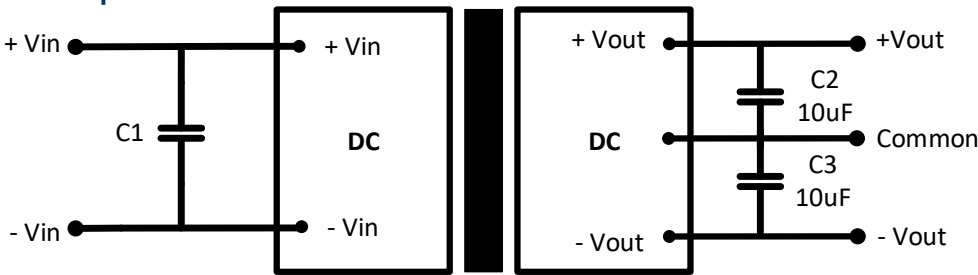

Model	12V/24V Vin	48V Vin
C1	100μF	10μF - 47μF

Recommended EMC Circuits

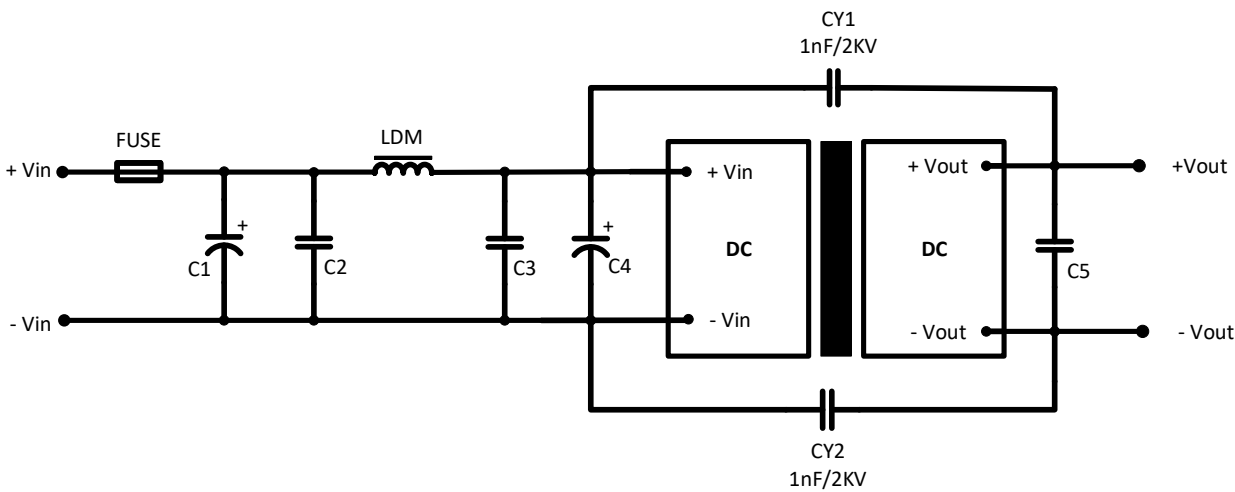

Single output

Model	12V/24V Vin	48V Vin
FUSE	Choose based on actual input current	
C1, C4	330μF/50V	330μF/100V
C2, C3	4.7μF/50V	4.7μF/100V
LDM	2.2μH/4A	2.2μH/2A
C5	Refer to the C2 in typical application circuit	

Dual output

Model	12V/24V Vin	48V Vin
FUSE	Choose based on actual input current	
C1, C4	330μF/50V	330μF/100V
C2, C3	4.7μF/50V	4.7μF/100V
LDM	4.7μH	
C5	Refer to the C2/C3 in typical application circuit	

Trimming (Single output)

Output voltage can be externally trimmed by utilizing the methods as shown below

Fixed Resistor

Variable Potentiometer

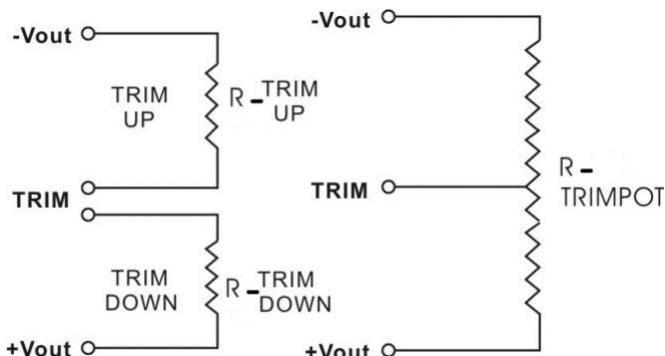

Leave open if not used.

3.3V output models

Trim down %	1	2	3	4	5	6	7	8	9	10
Vout (VDC)	3.267	3.234	3.201	3.168	3.135	3.102	3.069	3.036	3.003	2.97
Rt down (KΩ)	190.744	104.218	68.096	48.270	35.741	27.108	20.797	15.983	12.190	9.124
Trim up %	1	2	3	4	5	6	7	8	9	10
Vout (VDC)	3.333	3.366	3.399	3.432	3.465	3.498	3.531	3.564	3.597	3.63
Rt up (KΩ)	303.349	100.149	55.286	35.580	24.504	17.407	12.472	8.842	6.058	3.857

5V output models

Trim down %	1	2	3	4	5	6	7	8	9	10
Vout (VDC)	4.95	4.9	4.85	4.8	4.75	4.7	4.65	4.6	4.55	4.5
Rt down (KΩ)	89.996	47.446	29.793	20.131	14.036	9.840	6.775	4.439	2.598	1.111
Trim up %	1	2	3	4	5	6	7	8	9	10
Vout (VDC)	5.05	5.1	5.15	5.2	5.25	5.3	5.35	5.4	5.45	5.5
Rt up (KΩ)	238.676	81.473	46.044	30.398	21.581	15.923	11.985	9.085	6.861	5.101

12V output models

Trim down %	1	2	3	4	5	6	7	8	9	10
Vout (VDC)	11.88	11.76	11.64	11.52	11.4	11.28	11.16	11.04	10.92	10.8
Rt down (KΩ)	493.692	299.052	210.127	159.185	126.173	103.042	85.932	72.764	62.316	53.823
Trim up %	1	2	3	4	5	6	7	8	9	10
Vout (VDC)	12.12	12.24	12.36	12.48	12.6	12.72	12.84	12.96	13.08	13.2
Rt up (KΩ)	704.035	156.520	81.479	51.675	35.677	25.695	18.874	13.917	10.152	7.195

15V output models

Trim down %	1	2	3	4	5	6	7	8	9	10
Vout (VDC)	14.85	14.7	14.55	14.4	14.25	14.1	13.95	13.8	13.65	13.5
Rt down (KΩ)	632.483	398.237	286.114	220.359	177.137	146.560	123.787	106.169	92.132	80.687
Trim up %	1	2	3	4	5	6	7	8	9	10
Vout (VDC)	15.15	15.3	15.45	15.6	15.75	15.9	16.05	16.2	16.35	16.5
Rt up (KΩ)	1457.699	190.174	94.242	58.954	40.616	29.381	21.791	16.321	12.190	8.961

24V output models

Trim down %	1	2	3	4	5	6	7	8	9	10
Vout (VDC)	23.76	23.52	23.28	23.04	22.8	22.56	22.32	22.08	21.84	21.6
Rt down (KΩ)	1284.000	789.923	563.667	433.904	349.754	290.763	247.115	213.514	186.847	165.170
Trim up %	1	2	3	4	5	6	7	8	9	10
Vout (VDC)	24.24	24.48	24.72	24.96	25.2	25.44	25.68	25.92	26.16	26.4
Rt up (KΩ)	814.689	177.714	92.138	58.264	40.107	28.788	21.057	15.440	11.176	7.827

NOTE: 1. Datasheets are updated as needed and as such, specifications are subject to change without notice. Once printed or downloaded, datasheets are no longer controlled by Aimtec; refer to www.aimtec.com for the most current product specifications. 2. Product labels shown, including safety agency certifications on labels, may vary based on the date manufactured. 3. Mechanical drawings and specifications are for reference only. 4. All specifications are measured at an ambient temperature of 25°C, humidity<75%, nominal input voltage and at rated output load unless otherwise specified. 5. Aimtec may not have conducted destructive testing or chemical analysis on all internal components and chemicals at the time of publishing this document. CAS numbers and other limited information are considered proprietary and may not be available for release. 6. This product is not designed for use in critical life support systems, equipment used in hazardous environments, nuclear control systems or other such applications which necessitate specific safety and regulatory standards other the ones listed in this datasheet. 7. Warranty is in accordance with Aimtec's standard Terms of Sale available at www.aimtec.com.