

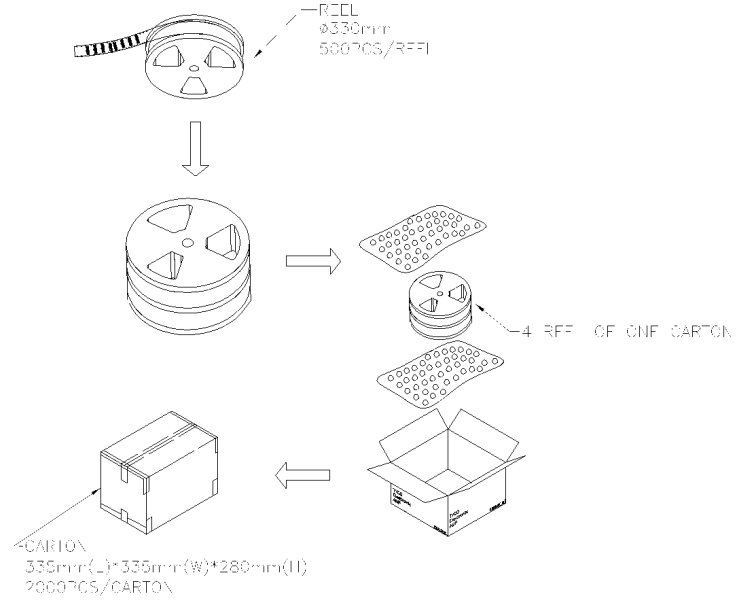

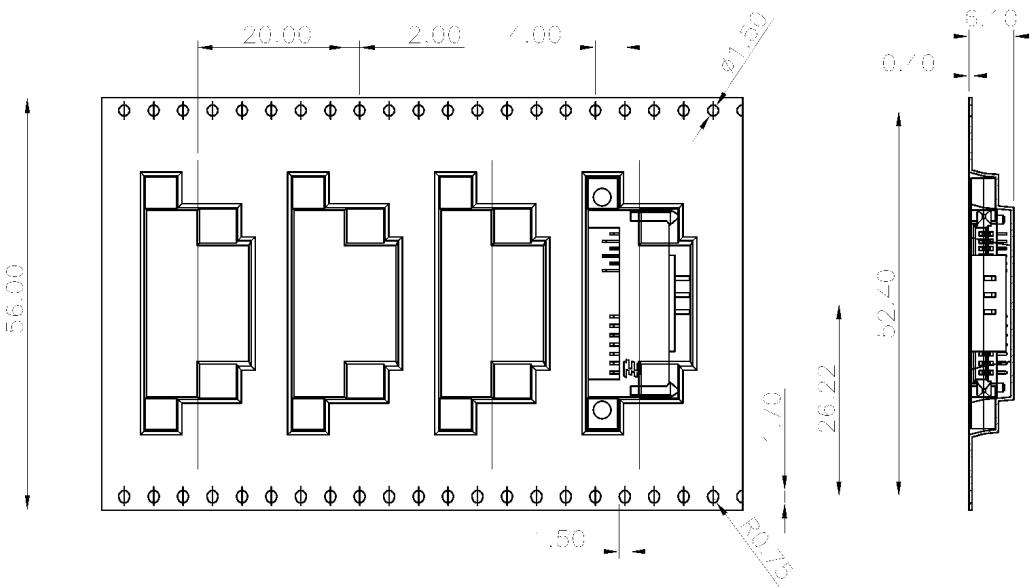

THIS DRAWING IS UNPUBLISHED. RELEASED FOR PUBLICATION AUG ,2006.  
 © COPYRIGHT BY TYCO ELECTRONICS CORPORATION. ALL RIGHTS RESERVED.

LOC	DIST	REVISIONS					
DW		P	LTR	DESCRIPTION	DATE	DWN	APVD
				SEE SHEET 1.			

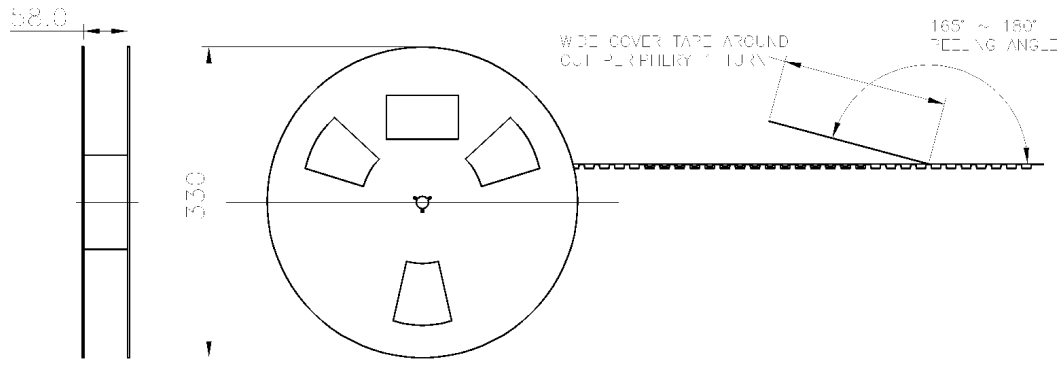

SCALE 2:1

4.9(Kg)	2.1(Kg)	500	2000
G/W	N/W	PCS/REEL	PCS/CARTON

THIS DRAWING IS A CONTROLLED DOCUMENT.		DWN	<b>STE</b> TE Connectivity			
DIMENSIONS: MM		CHK				
TOLERANCES UNLESS OTHERWISE SPECIFIED:		APVD	NAME			
0 PLC ±		PRODUCT SPEC	SLIMLINE SATA RECEPTACLE, RIGHT ANGLE, TH, 1.55H TOP MOUNT			
1 PLC ±		APPLICATION SPEC				
2 PLC ±		WEIGHT	SIZE	CAGE CODE	DRAWING NO	RESTRICTED TO
3 PLC ±		CUSTOMER DRAWING	A3	00779	C-1735777	
4 PLC ±			SCALE	SHEET	3 of 3	REV
4 PLC ANGLES ±						
MATERIAL						
FINISH						