

REVISION HISTORY			
REV	DESCRIPTION	DATE	APPROVED
-	NRN 34839	07/08	STW

PRODUCT DATA DRAWING

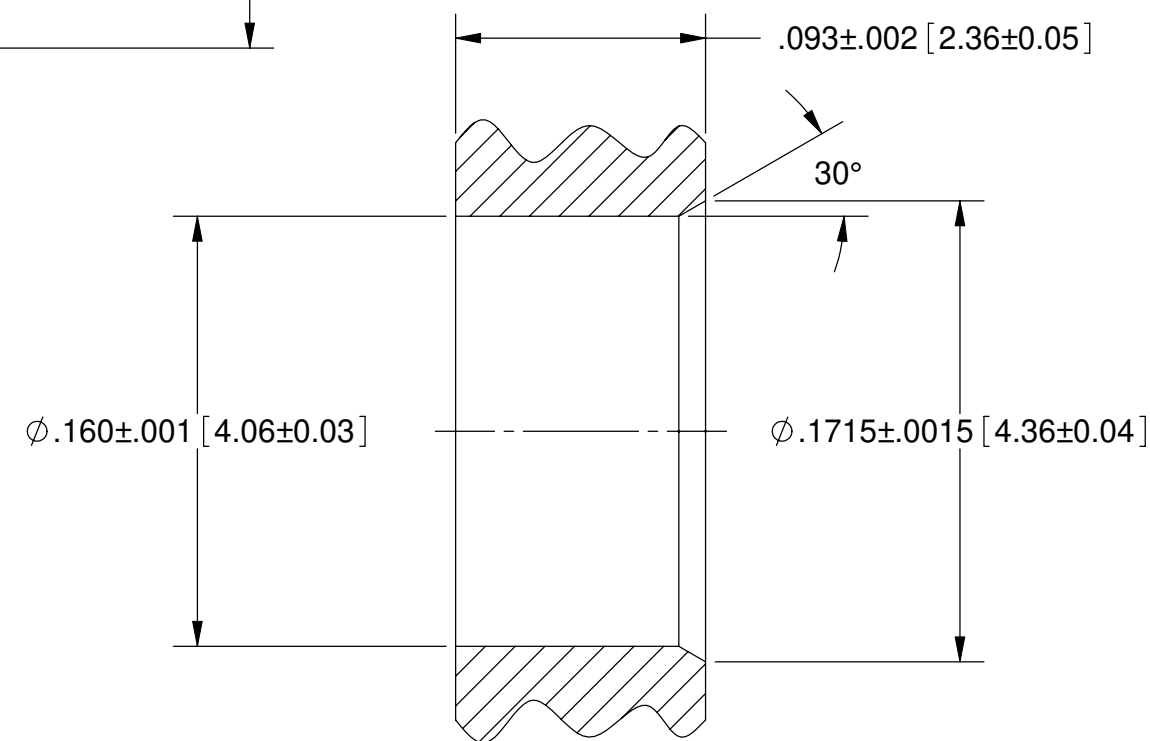
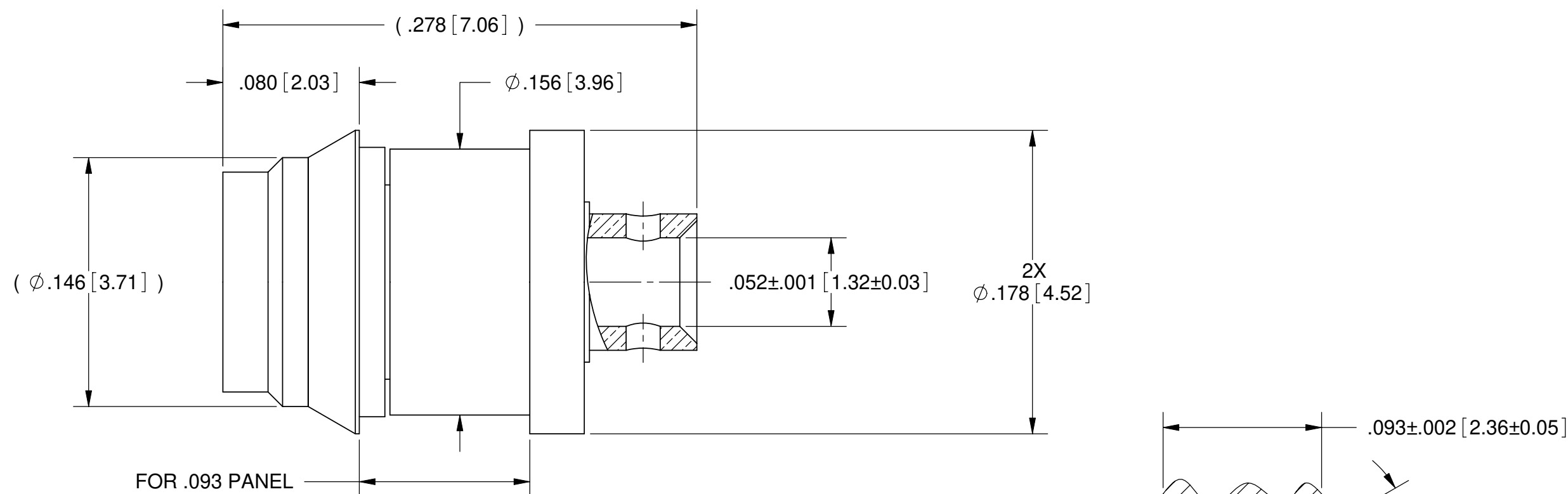

RECOMMENDED PANEL HOLE

MATERIAL:

BODY: STAINLESS STEEL PER AMS-5640, UNS S30300 (TYPE 1)

SLEEVE, CONTACT & RETAINING RING: BERYLLIUM COPPER PER ASTM B196, ALLOY No. UNS C17300, TD04

INSULATOR: PTFE PER ASTM D1710, TYPE I, GRADE 1, CLASS B

FINISH:

BODY: PASSIVATED PER AMS-QQ-P-35, TYPE II

SLEEVE, CONTACT & RETAINING RING: GOLD PER ASTM B 488, TYPE II, CODE C, CLASS 1.27; OVER NICKEL PER AMS-QQ-N-290, CLASS 1, .00005" MIN.

PERFORMANCE:

IMPEDANCE: 50 OHMS
 FREQ. RANGE: DC TO 40.0 GHz
 VSWR: 1.25:1 DC TO 26.5 GHz
 1.35:1 DC TO 40.0 GHz

DWV: 325 VRMS
 OPERATING TEMP.: -55°C TO +125°C

REMOVAL TOOL P/N 500-32-028

MATERIAL: SEE NOTES	DIMENSIONS ARE IN INCHES TOLERANCES: FRACTIONAL: ±1/64 ANGULAR: X° ±1'0" X"X' ±15'	UNLESS OTHERWISE SPECIFIED 1) ALL DIMENSIONS ARE IN INCHES (MILLIMETERS) 2) ALL DIMENSIONS ARE AFTER PLATING. 3) BREAK CORNERS & EDGES .005 R. MAX. 4) CHAM. 1ST & LAST THREADS. 5) SURFACE ROUGHNESS 63-MIL-STD-10. 6) DIA.'S ON COMMON CENTERS TO BE CONCENTRIC WITHIN .005 T.I.R. 7) REMOVE ALL BURRS	SV Microwave, Inc. 2400 Centrepark West Drive, Suite 100 West Palm Beach, FL 33409
FINISH: SEE NOTES	DECIMAL: .X ±.030 .XX ±.010 .XXX ±.005	INTERPRET DIMENSIONS AND TOLERANCES PER ASME Y14.5M - 1994	TITLE: SMPM MALE SB SNAP-IN FOR .093 PANEL FOR Ø.047 S.R. CABLE
SURFACE AREA: N/A	THIRD ANGLE PROJECTION	DRAWN: DAL 08/06/08 CHECKED: STW 08/06/08 APPROVED: STW 08/06/08	SIZE: B CAGE CODE: 95077 DWG. NO.: 3211-40003
PROPRIETARY THE INFORMATION CONTAINED IN THIS DRAWING IS THE SOLE PROPERTY OF SV MICROWAVE, INC. ANY REPRODUCTION IN PART OR AS A WHOLE WITHOUT THE WRITTEN PERMISSION OF SV MICROWAVE, INC IS PROHIBITED.			SCALE: 14:1 SHEET 1 OF 1