

RECOMMENDED LAND PATTERN (SCALE:FREE)

(RECOMMENDED METAL MASK THICKNESS:10:1)

NOTE 1 LEAD CO-PLANARITY INCLUDING REINFORCED METAL FITTINGS SHALL BE 0.1 MAX.

2. TO BE DELIVERED WITH TAPE AND REEL PACKAGES.

SEE ATTACHED PACKAGING SPECIFICATIONS FOR DETAILS.

3. NOTE THAT PREVENTIVE HOLE FOR SINK MARK COULD BE ADDED FOR IMPROVEMENT.
 THE QUALITY REMAINS GOOD, EVEN WITH THE DARK SPOTS, WHICH COULD OCCASIONALLY OCCUR ON MOLDED PLASTIC.

5	PHOSPHOR BRONZE (PLATED MATERIAL)	TIN PLATING (REFLOW FINISHED) 1μm MIN OVER COPPER 0.5μm MIN	10 (CONNECTOR)
4	PHOSPHOR BRONZE	GOLD PLATING 0.05μmMIN OVER NIOBEL 1μmMIN	9 POLYSTYRENE
3	PHOSPHOR BRONZE	GOLD PLATING 0.05μmMIN OVER NIOBEL 1μmMIN	8 POLYESTER
2	PA	DEEP BROWN UL94V-0	7 POLYSTYRENE
1	LCP	BLACK UL94V-0	6 PHOSPHOR BRONZE (PLATED MATERIAL)
			14μm MIN OVER COPPER 0.5μm MIN

UNITS	SCALE	COUNT	DESCRIPTION OF REVISIONS	DESIGNED	CHECKED	DATE
mm	7:1	27	DIS-F-006028	TY: M0G1	NM: NISHIMATSU	12.02.16
MATERIAL		FINISH . REMARKS		FINISH . REMARKS		
NO.		NO.		NO.		
APPROVED: MO. ISHIDA		05.01.05		DRAWING		EDC3-154381-03
CHECKED: YN. TAKASHITA		05.01.05		PART		FH26-**-S-0.3SHW(05)
DESIGNED: SJ. OKAMURA		05.01.05		CODE		CL580
DRAWN: SJ. OKAMURA		05.01.05		NO.		

RECOMMENDED FPC(FREE)
 (SCALE:FREE)

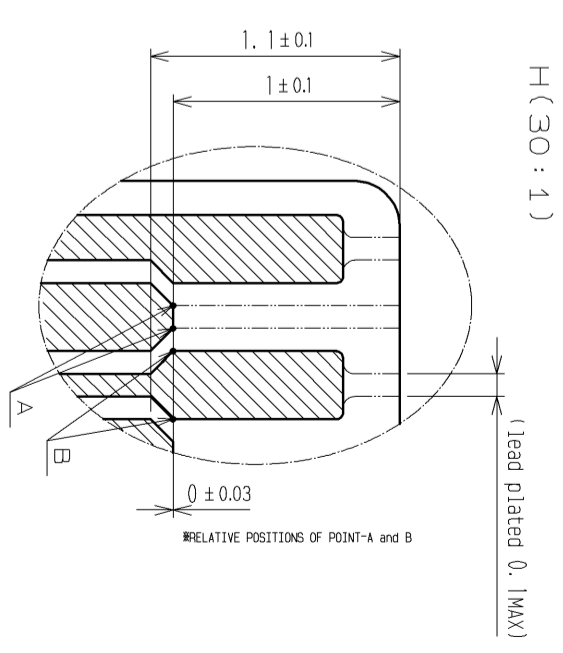
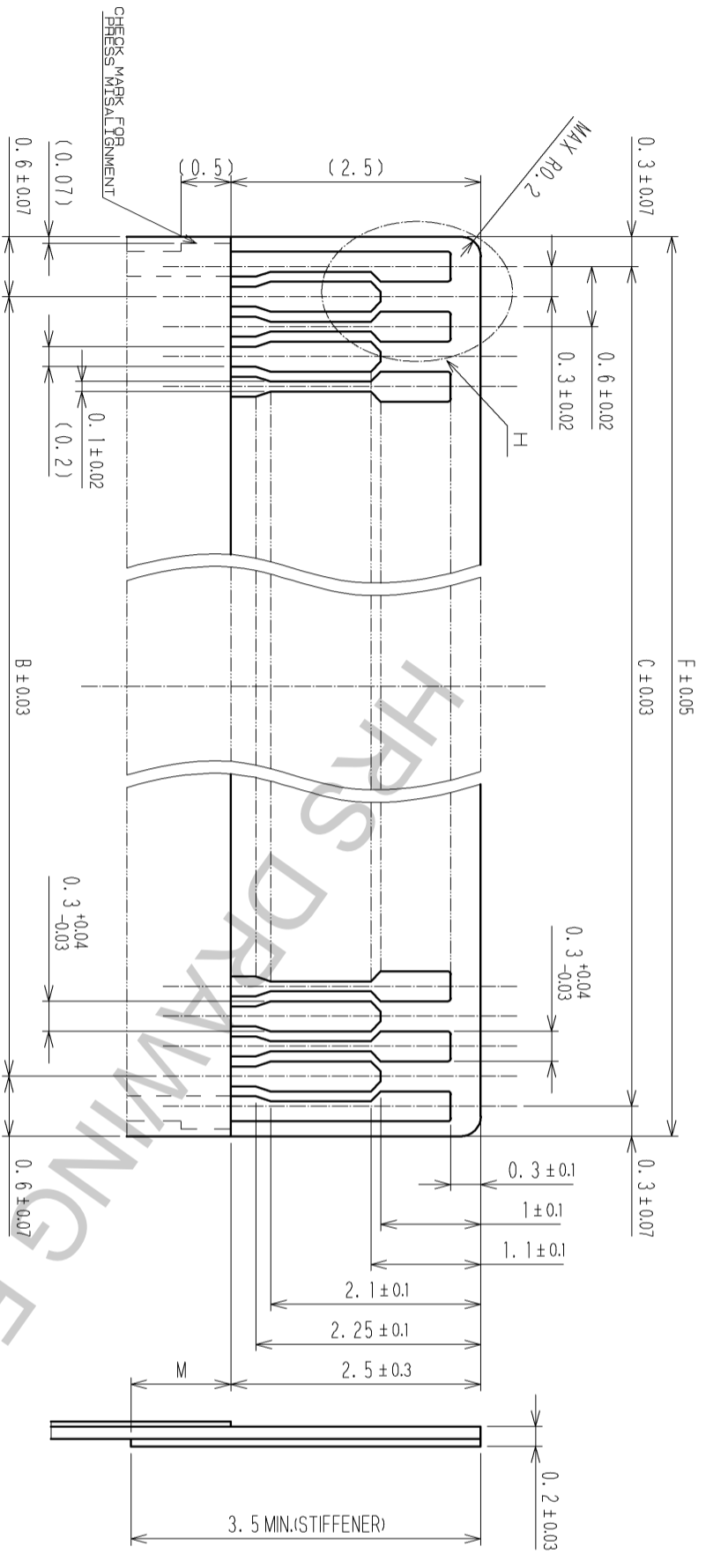

△ DIMENSION M MUST BE 0.5mm MIN WHEN THE STIFFENER IS SHORTER THAN 3.5mm

FPC CONSTRUCTION Recommended Specifications

MATERIAL NAME	MATERIAL	THICKNESS(mm)
COVERING FILM LAYER.	POLYIMIDE 1mil thick.	25
COVER ADHESIVE		25
SURFACE TREATMENT	1 μm TO 5 μm NICKEL, UNDERPLATED 0.2 μm GOLD PLATED.	(3)
COPPER FOIL	CU 1 OZ	35
BASE ADHESIVE	HEAT-HARDENED ADHESIVE	25
BASE FILM	POLYIMIDE 1mil thick	25
REINFORCEMENT MATERIAL ADHESIVE	HEAT-HARDENED ADHESIVE	40
STIFFENER	POLYIMIDE 3mil thick	75

● 24mmMAX.

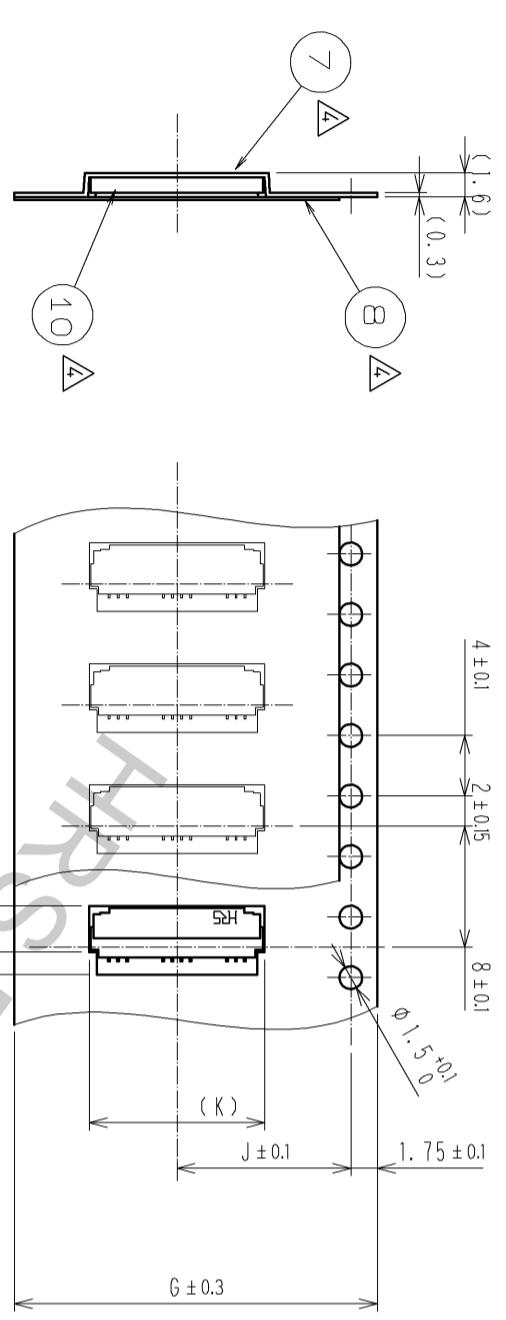

△ EMBOSSED CARRIER TAPE DIMENSION (2:1)

● 32mmMIN.

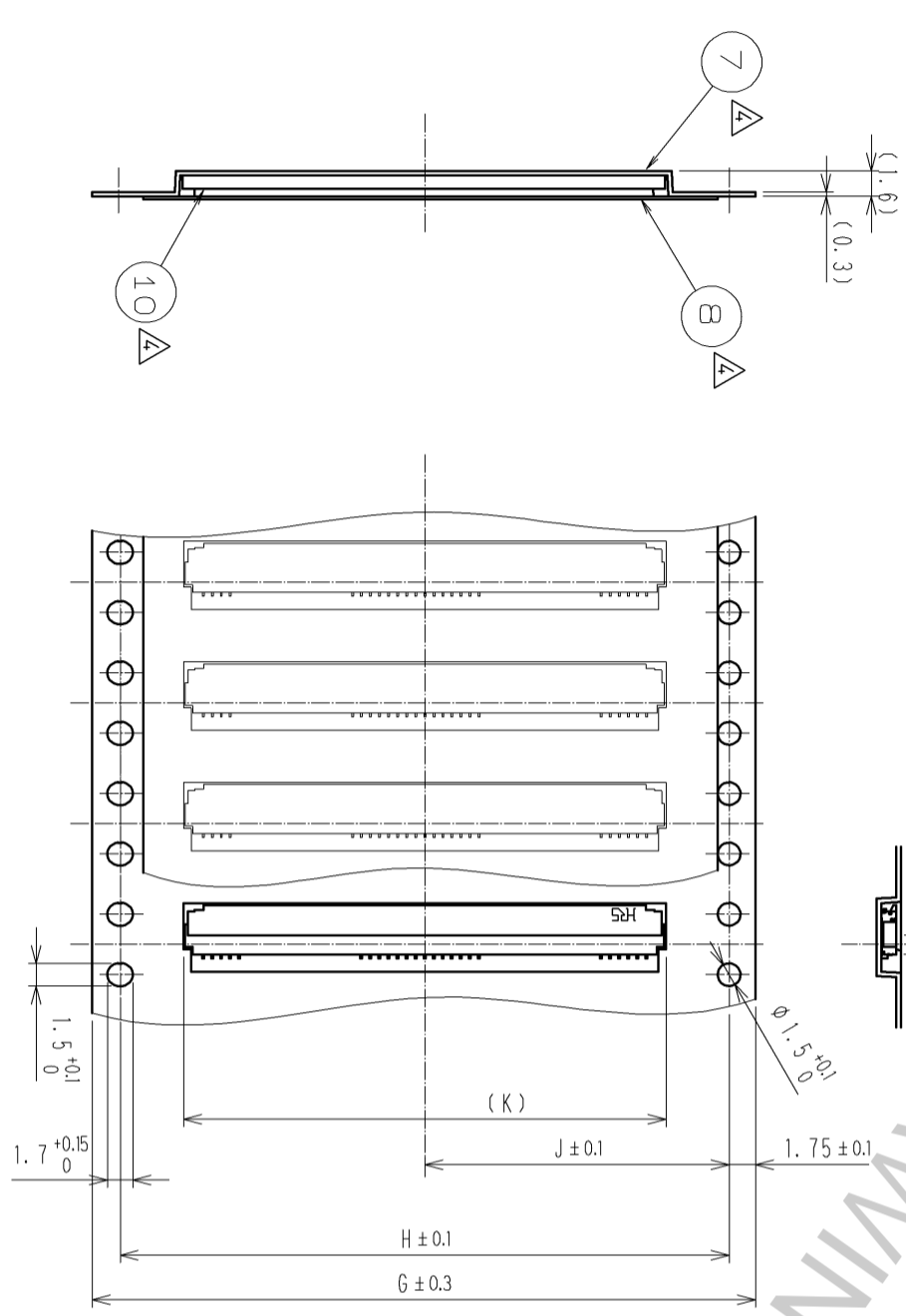

REEL DIMENSION (FREE)

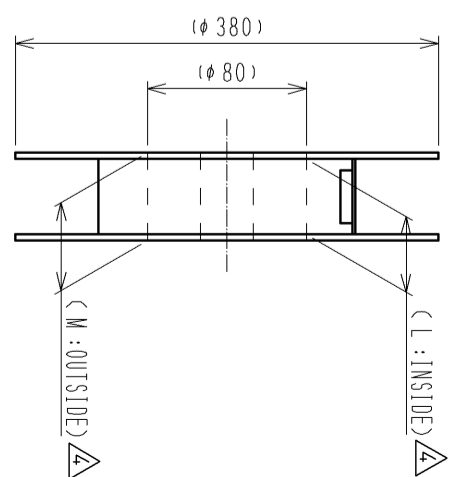
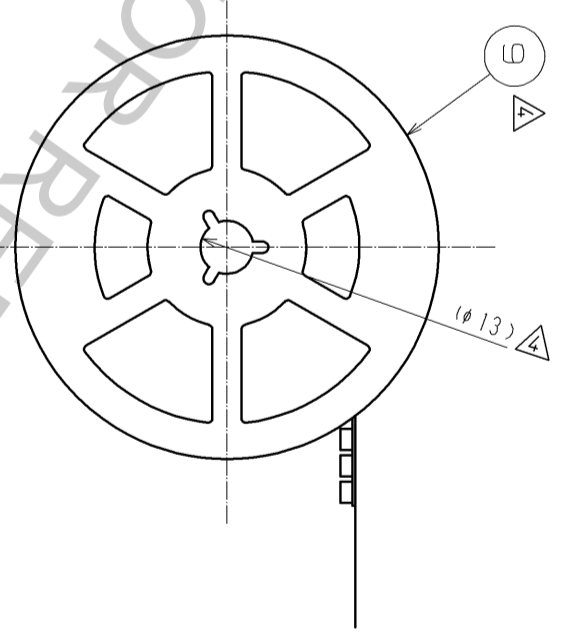

NOTE △4 THE DIMENSIONS IN PARENTHESES ARE FOR REFERENCE.
 △5 PER REEL : 5000 CONNECTORS.
 △6 REFER TO JIS C 0806 (PACKAGING OF COMPONENTS FOR AUTOMATIC HANDLING.)

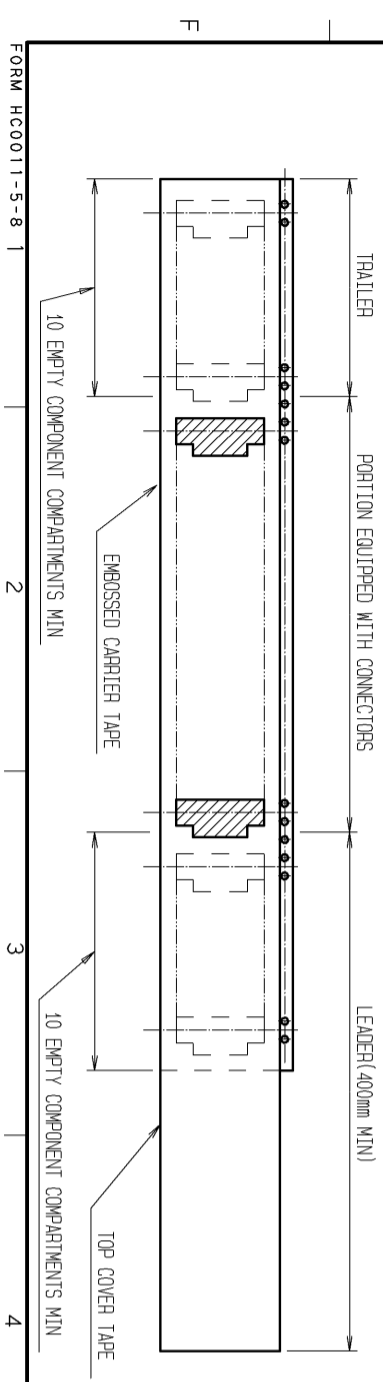

HR5	DRAWING NO.	EDC3-154381-03
	PART NO.	FH26-**-S-0.3SHW(05)
	CODE NO.	CL0580

FORM HC0011-5-8

2

3

4

5

6

7

8

PART NUMBER	CL	NUMBER OF CONTACT	DIMENSION OF CONNECTOR, FPC PATTERN AND METAL MASK						DIMENSION OF DRAWING FOR PACKING					
			A	B	C	D	E	F	G	H	J	K	L	M
FH26-13S-0.3SHW(05)	CL580-0209-3-05	13	5.4	3.0	3.6	4.23	4.9	4.2	16	-	7.5	5.6	17.4	21.4
FH26-15S-0.3SHW(05)	CL580-0218-4-05	15	6.0	3.6	4.2	4.83	5.5	4.8	16	-	7.5	6.2	17.4	21.4
FH26-17S-0.3SHW(05)	CL580-0217-1-05	17	6.6	4.2	4.8	5.43	6.1	5.4	16	-	7.5	6.8	17.4	21.4
FH26-21S-0.3SHW(05)	CL580-0207-8-05	21	7.8	5.4	6.0	6.63	7.3	6.6	16	-	7.5	8.0	17.4	21.4
FH26-23S-0.3SHW(05)	CL580-0203-7-05	23	8.4	6.0	6.6	7.23	7.9	7.2	16	-	7.5	8.6	17.4	21.4
FH26-25S-0.3SHW(05)	CL580-0208-0-05	25	9.0	6.6	7.2	7.83	8.5	7.8	16	-	7.5	9.2	17.4	21.4
FH26-27S-0.3SHW(05)	CL580-0204-0-05	27	9.6	7.2	7.8	8.43	9.1	8.4	16	-	7.5	9.8	17.4	21.4
FH26-29S-0.3SHW(05)	CL580-0216-9-05	29	10.2	7.8	8.4	9.03	9.7	9.0	24	-	11.5	10.4	25.4	29.4
FH26-31S-0.3SHW(05)	CL580-0214-3-05	31	10.8	8.4	9.0	9.63	10.3	9.6	24	-	11.5	11.0	25.4	29.4
FH26-33S-0.3SHW(05)	CL580-0210-2-05	33	11.4	9.0	9.6	10.23	10.9	10.2	24	-	11.5	11.6	25.4	29.4
FH26-35S-0.3SHW(05)	CL580-0205-2-05	35	12.0	9.6	10.2	10.83	11.5	10.8	24	-	11.5	12.2	25.4	29.4
FH26-37S-0.3SHW(05)	CL580-0224-7-05	37	12.6	10.2	10.8	11.43	12.1	11.4	24	-	11.5	12.8	25.4	29.4
FH26-39S-0.3SHW(05)	CL580-0201-1-05	39	13.2	10.8	11.4	12.03	12.7	12.0	24	-	11.5	13.4	25.4	29.4
FH26-41S-0.3SHW(05)	CL580-0206-5-05	41	13.8	11.4	12.0	12.63	13.3	12.6	24	-	11.5	14.0	25.4	29.4
FH26-45S-0.3SHW(05)	CL580-0211-5-05	45	15.0	12.6	13.2	13.83	14.5	13.8	24	-	11.5	15.2	25.4	29.4
FH26-51S-0.3SHW(05)	CL580-0200-9-05	51	16.8	14.4	15.0	15.63	16.3	15.6	24	-	11.5	17.0	25.4	29.4
FH26-55S-0.3SHW(05)	CL580-0221-9-05	55	18.0	15.6	16.2	16.83	17.5	16.8	32	28.4	14.2	18.2	33.4	37.4
FH26-57S-0.3SHW(05)	CL580-0212-8-05	57	18.6	16.2	16.8	17.43	18.1	17.4	32	28.4	14.2	18.8	33.4	37.4
FH26-61S-0.3SHW(05)	CL580-0213-0-05	61	19.8	17.4	18.0	18.63	19.3	18.6	32	28.4	14.2	20.0	33.4	37.4
FH26-71S-0.3SHW(05)	CL580-0202-4-05	71	22.8	20.4	21.0	21.63	22.3	21.6	44	40.4	20.2	23.0	45.4	49.4

REFERENCE

HRS	
DRAWING NO. EDC3-154381-03	PART NO. FH26-**-S-0.3SHW(05)
PART CODE CL0580	CL0580

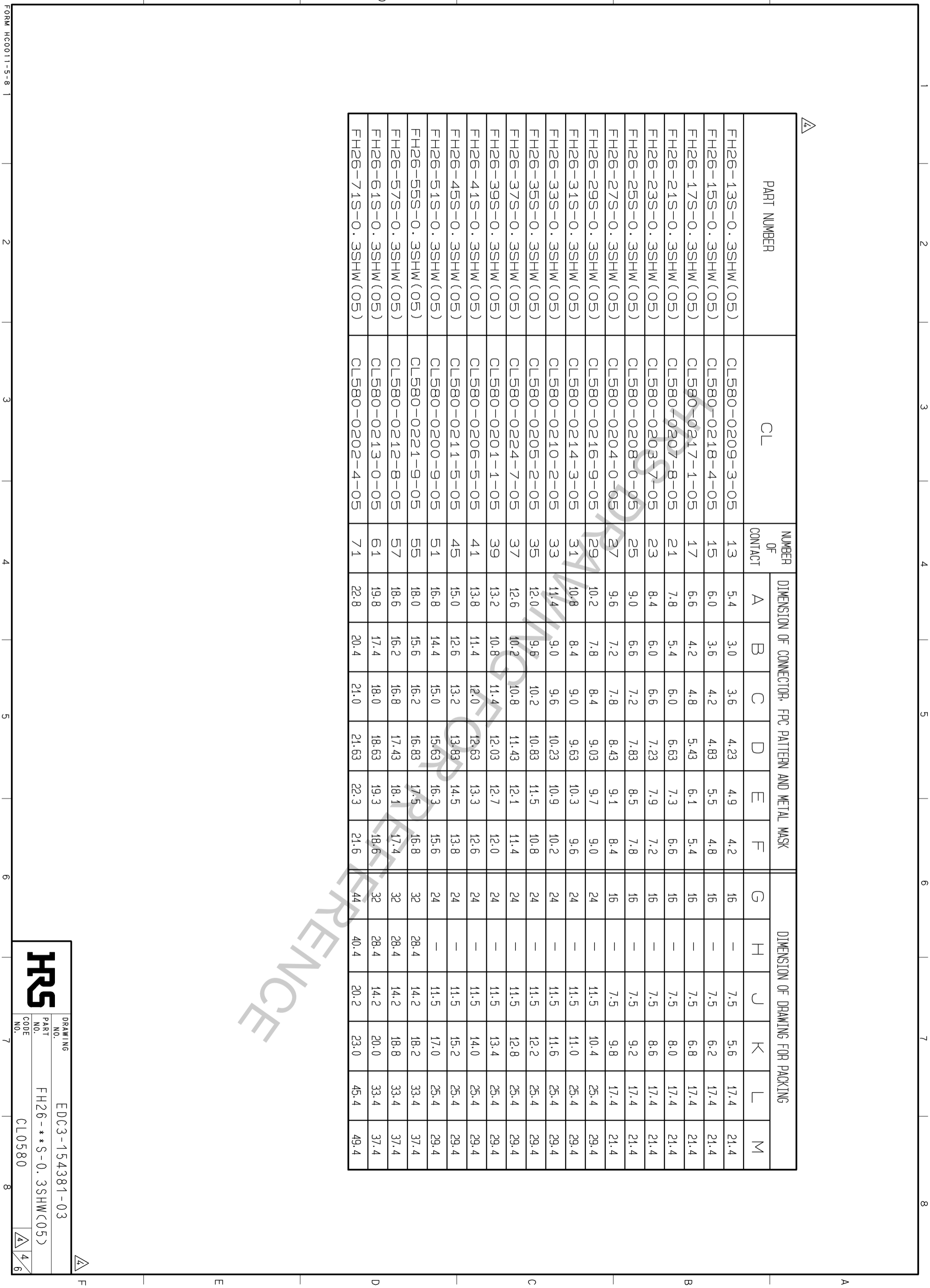

FORM HC0011-5-8

This connector is small and thin and requires delicate and careful handling.
 Read through the instructions shown below and handle the connector properly.
 Each values indicating here are for reference and may differ from standard value.

[INSTRUCTIONS FOR MOUNTING ON THE BOARD]

- ◆Warp of Board
 Minimize warp of the board as much as possible.
 Lead co-planarity including reinforced metal fittings is 0.1 mm or less.
 Too much warp of the board may result in a soldering failure.

- △Flexible board design
 Please make sure to put a stiffener on the backside of the flexible board.
 We recommend a glass epoxy material with the thickness of 0.3mm MIN.

- △Load to Connector
 Do not add 0.5N or greater external force when unreeel or pick and place the connector etc.
 or it may get broken.
 In addition, do not insert the FPC or operate the connector before mounting it.

△INSTRUCTIONS FOR PCB HANDLING AFTER MOUNTING THE CONNECTOR]

- ◆Load to Board
 .Splitting a large board into several pieces
 .Screwing the board
 Avoid the handling described above so that no force is exerted on the board during the assembly process.
 Otherwise, the connector may become defective.

- ◆Amount of Warp
 The warp of a 100-mm wide board should be 0.5 mm or less.
 The warp of board suffers stress on connector and the connector may become defective.

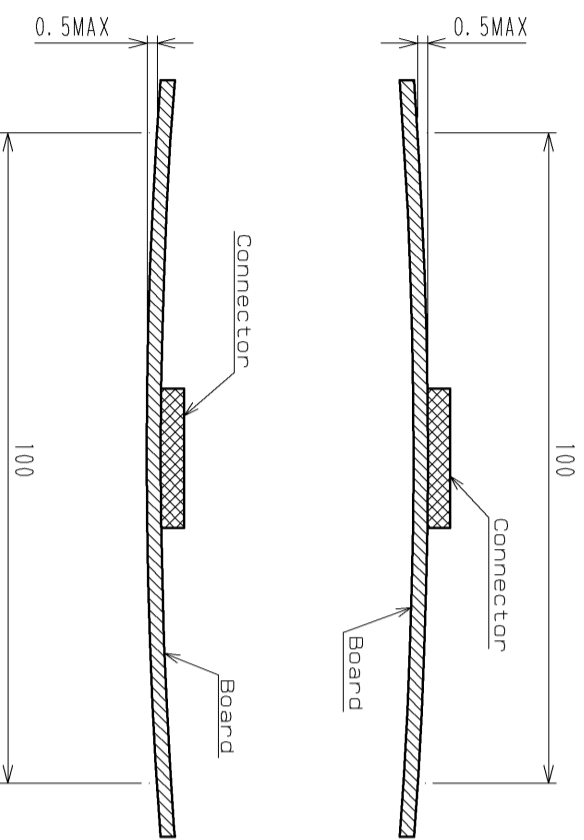

[INSTRUCTIONS ON INSERTING FPC AND CONNECTION]

- ◆ Use of the Lock Lever
 1. Be very careful not to apply excessive force when releasing the lock lever
 in the initial position (with no FPC inserted).
 If you use your nail or finger as shown below, the terminals may be deformed.

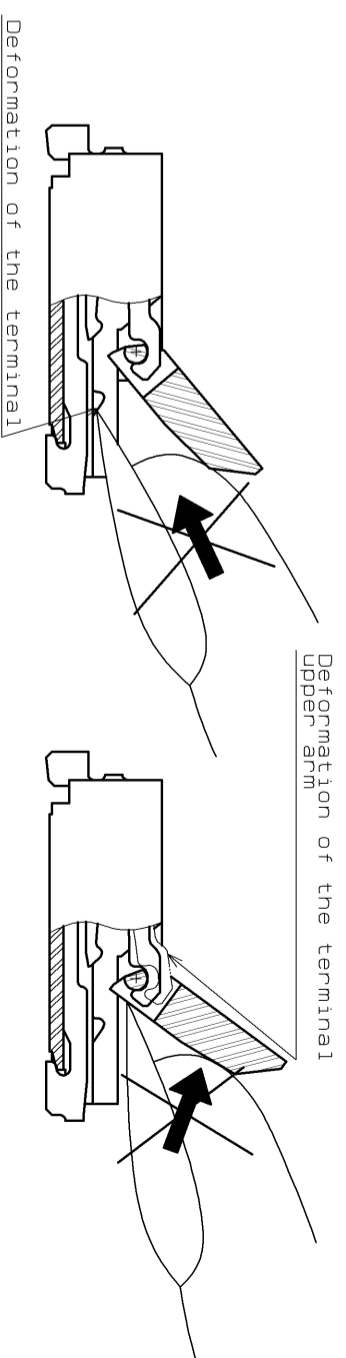

Example 1

Example 2

- 2. The lock lever rotates around the rotational axis as shown below.
 Rotate the lock lever.

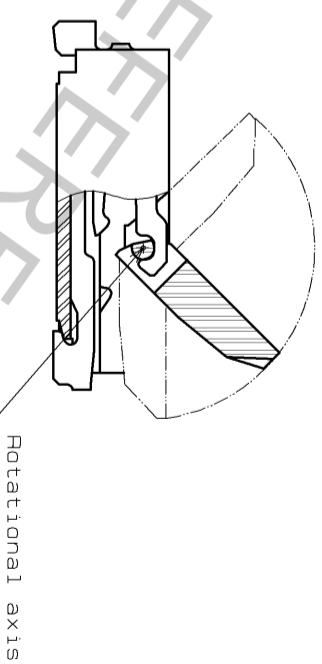

- 3. The lock lever will not open more than 135°. Do not apply any force backward beyond this point. Otherwise, the lock lever may come off or break.

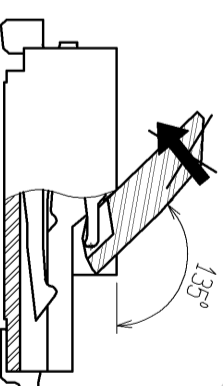

4. Move the lock lever at approximately the center.
 5. Do not pinch or pick the lock lever to lift it as shown below. Otherwise, it may break.
 (Do not carry out any operation other than rotating the lever as shown in 2 above.)

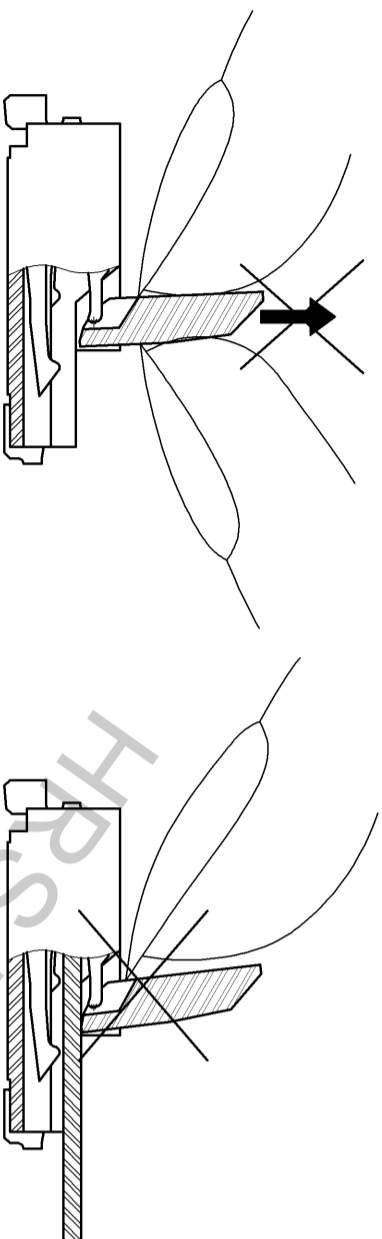

◆Direction of Contacts
 This connector has contacts on the bottom. Thus, insert the FPC with the exposed conductors' face down.

- ◆Inserting the FPC
 1. Insert the FPC horizontally along the surface and at a right angle to the connector.
 Insert it properly to the very end.
 If the FPC is inserted at a slant (incorrectly), the conductors may short-circuit due to pitch shift or the edge of the FPC may catch in the terminals, resulting in deformation of the terminals.
 This connector has a ZIF structure, and its effective engagement length is 0.35 mm (when the recommended FPC nominal is used).
 Use the lock lever carefully to prevent the FPC from dislocating after inserting it.

2. Do not insert the FPC diagonally from above.
 If the FPC is inserted at a slant (incorrectly) as shown below in the FPC insertion process, the FPC may bend and patterns may break or the FPC may not insert completely, resulting in improper conduction.

✳Keep a sufficient FPC insertion space in the stage of the layout in order to avoid incorrect FPC insertion.
 Besides, it is not difficult to insert FPC correctly all the way to the end.
 Design the proper layout of parts.

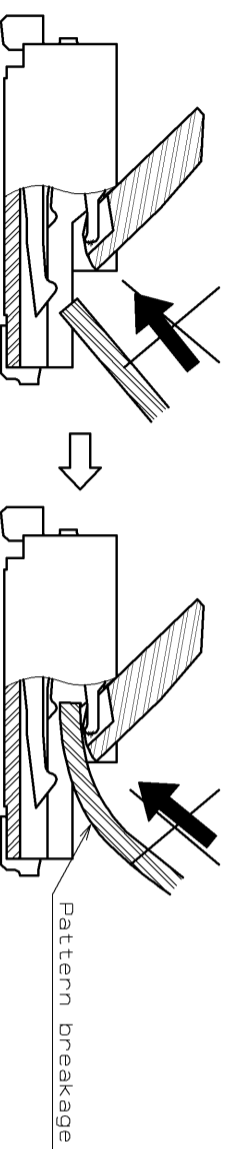

◆Checking the Locking Condition

In the locked condition, make sure that the lock lever is horizontal on the board surface.
 Do not apply excessive force to it near the 0° position of the lever.
 Otherwise, the terminals may be deformed. (Allowable force: 1 N or less)

INSTRUCTIONS ON FPC LAYOUT AFTER CONNECTION

◆Load to FPC
 Be very careful not to apply any force to the FPC after inserting it.
 Otherwise, the connector may become unlocked or the FPC may break.
 Fix the FPC, in particular, when loads are applied to it continuously.
 Design the FPC layout with care not to bend it sharply near the insertion opening.

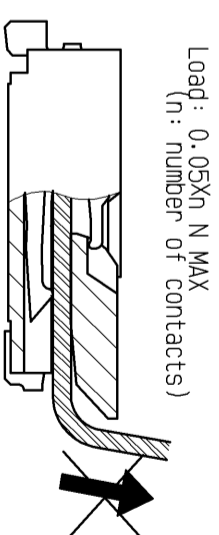

INSTRUCTIONS ON REMOVING FPC

◆Release the lock lever to remove the FPC.

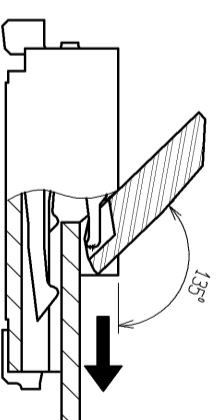

OTHER INSTRUCTIONS

◆Instructions on Manual Soldering
 Follow the instructions shown below when soldering the connector manually during repair work, etc.
 1. Do not perform reflow soldering or manual soldering with the FPC inserted into the connector.
 2. Do not heat the connector excessively. Be very careful not to let the soldering iron contact any parts other than connector leads. Otherwise, the connector may be deformed or melt.
 3. Do not use excessive solder (or flux).
 If excessive solder (or flux) is used on the terminals, solder or flux may adhere to the contacts or rotating parts of the lock lever, resulting in poor contact or a rotation failure of the lock lever.
 Supplying excessive solder to the reinforcing bracket may hinder lock lever rotation, resulting in breakage of the connector.