

ISL8225M

Dual 15A/Single 30A Step-Down Power Module

FN7822  
Rev 2.00  
December 8, 2014

The ISL8225M is a fully-encapsulated step-down switching power supply that can deliver up to 100W output power from a small 17mm square PCB footprint. The two 15A outputs may be used independently or combined to deliver a single 30A output. Designing a high-performance board mounted power supply has never been simpler – only a few external components are needed to create a very dense and reliable power solution.

Automatic current sharing and phase interleaving allow up to six modules to be paralleled for 180A output capability. 1.5% output voltage accuracy, differential remote voltage sensing and fast transient response create a very high-performance power system. Built-in output overvoltage, overcurrent and over-temperature protection enhance system reliability.

The ISL8225M is available in a thermally-enhanced QFN package. Excellent efficiency and low thermal resistance permit full power operation without heat sinks or fans. In addition, the QFN package with external leads permits easy probing and visual solder inspection.

**Related Literature**

- [AN1789](#) “ISL8225MEVAL2Z Evaluation Board User Guide”
- [AN1790](#) “ISL8225MEVAL3Z Evaluation Board User Guide”
- [AN1793](#), “ISL8225MEVAL4Z Evaluation Board User Guide”
- [ISL8225M 110A Thermal Performance Video](#)

**Features**

- Fully-encapsulated dual step-down switching power supply
- Up to 100W output from a 17mmx17mm square PCB footprint
- Dual 15A or single 30A output
- Up to 95% conversion efficiency
- 4.5V to 20V input voltage range
- 0.6V to 7.5V output voltage range
- 1.5% output voltage accuracy with differential remote sensing
- Up to six modules may be paralleled to support 180A output current
- Output overvoltage, overcurrent and over-temperature protection
- Full power operation without heat sinks or fans
- QFN package with exposed leads permits easy probing and visual solder inspection

**Applications**

- Computing, networking and telecom infrastructure equipment
- Industrial and medical equipment
- General purpose point-of-load (POL) power

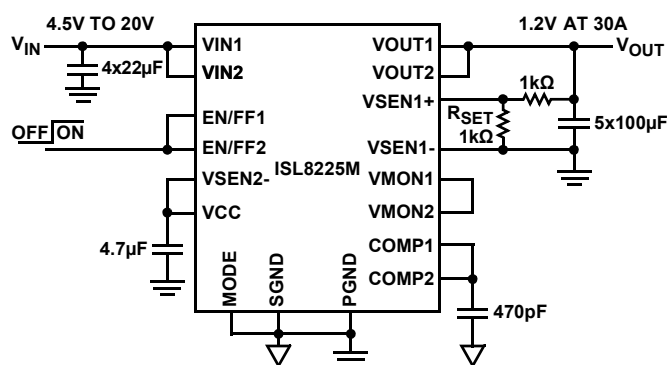

NOTE: ALL PINS NOT SHOWN ARE FLOATING.

FIGURE 1. COMPLETE 30A STEP-DOWN POWER SUPPLY

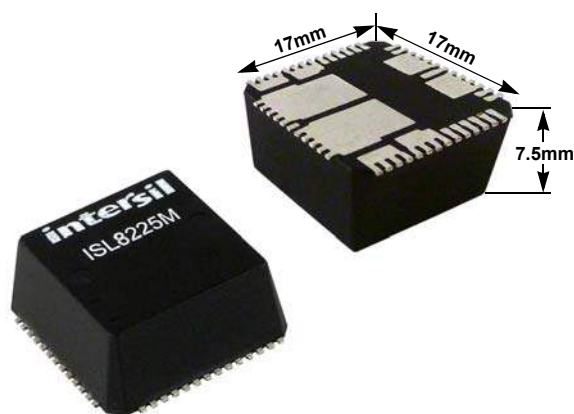
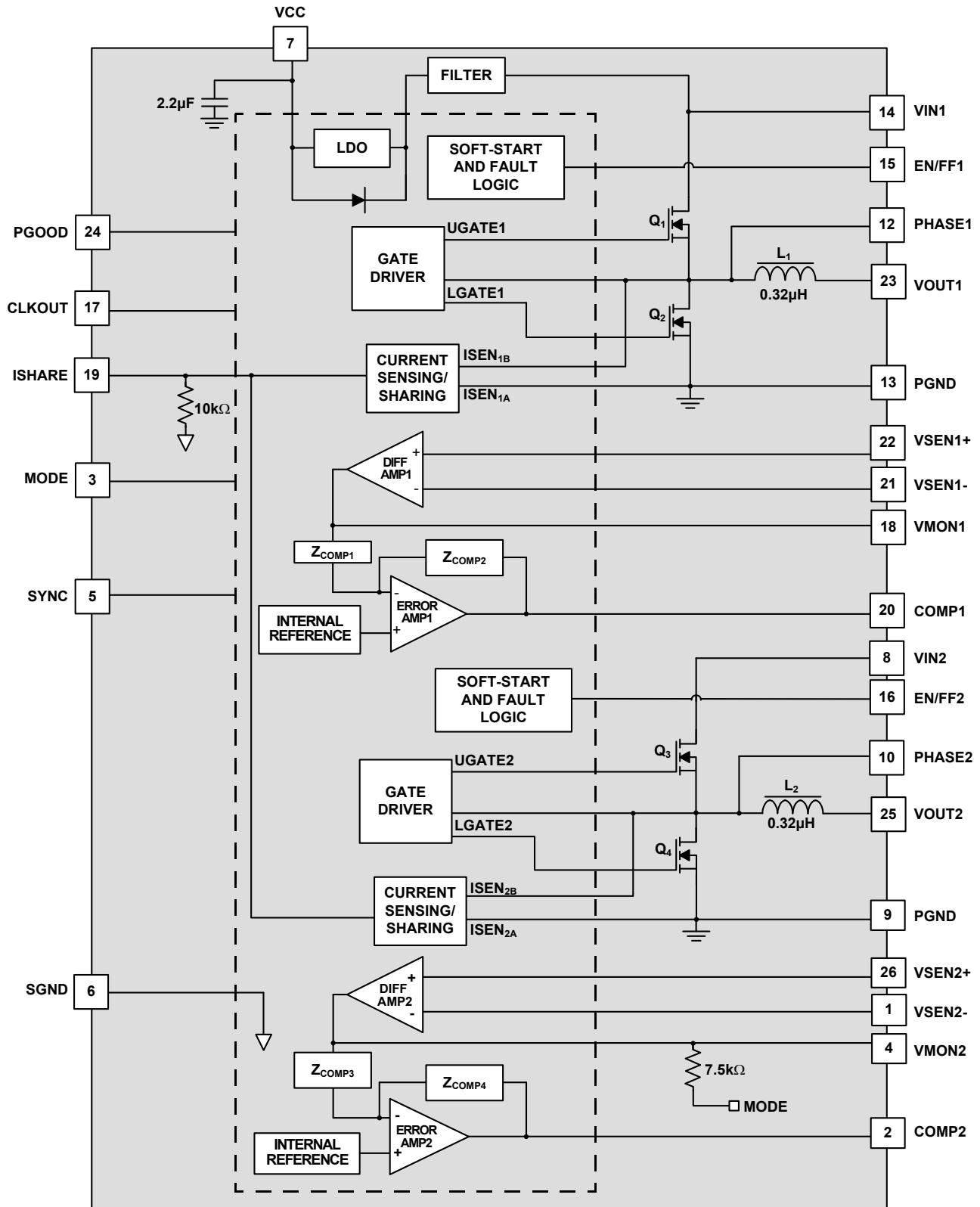

FIGURE 2. SMALL FOOTPRINT WITH HIGH POWER DENSITY

# Table of Contents

|   |           |
|---|-----------|
| <b>Pinout Internal Circuit</b> .....                | <b>3</b>  |
| <b>Ordering Information</b> .....                   | <b>4</b>  |
| <b>Pin Descriptions</b> .....                       | <b>6</b>  |
| <b>Absolute Maximum Ratings</b> .....               | <b>7</b>  |
| <b>Thermal Information</b> .....                    | <b>7</b>  |
| <b>Recommended Operating Conditions</b> .....       | <b>7</b>  |
| <b>Electrical Specifications</b> .....              | <b>7</b>  |
| <b>Typical Performance Characteristics</b> .....    | <b>10</b> |
| Efficiency Performance .....                        | 10        |
| Transient Response Performance .....                | 11        |
| Start-up and Short Circuit Performance .....        | 12        |
| <b>Typical Application Circuits</b> .....           | <b>13</b> |
| <b>Application Information</b> .....                | <b>22</b> |
| Programming the Output Voltage .....                | 22        |
| Selection of Input Capacitor .....                  | 22        |
| Selection of Output Capacitors .....                | 23        |
| EN/FF Turn ON/OFF .....                             | 23        |
| Thermal Considerations .....                        | 23        |
| <b>Functional Description</b> .....                 | <b>23</b> |
| Initialization .....                                | 23        |
| Enable and Voltage Feed-forward .....               | 23        |
| Soft-Start .....                                    | 24        |
| Power-Good .....                                    | 24        |
| Current Share .....                                 | 25        |
| Overvoltage Protection (OVP) .....                  | 25        |
| Over-Temperature Protection (OTP) .....             | 25        |
| Overcurrent Protection (OCP) .....                  | 25        |
| Frequency Synchronization and Phase Lock Loop ..... | 25        |
| Tracking Function .....                             | 26        |
| Mode Programming .....                              | 26        |
| Two Phase Parallel Mode Operation .....             | 27        |
| Layout Guide .....                                  | 27        |
| Current Derating .....                              | 28        |
| <b>Package Description</b> .....                    | <b>28</b> |
| PCB Layout Pattern Design .....                     | 28        |
| Thermal Vias .....                                  | 28        |
| Stencil Pattern Design .....                        | 28        |
| <b>Derating Curves</b> .....                        | <b>29</b> |
| Reflow Parameters .....                             | 31        |
| <b>Revision History</b> .....                       | <b>32</b> |
| <b>About Intersil</b> .....                         | <b>32</b> |
| <b>Package Outline Drawing</b> .....                | <b>33</b> |

# Pinout Internal Circuit



## Ordering Information

| PART NUMBER<br>(Notes 2, 3) | PART<br>MARKING                                   | TEMP RANGE (°C)<br>(Note 4) | PACKAGE<br>(RoHS Compliant) | PKG.<br>DWG. # |
|-----------------------------|---|-----------------------------|-----------------------------|----------------|
| ISL8225MIRZ                 | ISL8225M  | -40 to +125                 | 26 Ld QFN                   | L26.17x17      |
| ISL8225MIRZ-T (Note 1)      | ISL8225M  | -40 to +125                 | 26 Ld QFN                   | L26.17x17      |
| ISL8225MEVAL2Z              | 6 Phase 90A Evaluation Board                      |                             |                             |                |
| ISL8225MEVAL3Z              | Dual Phase Single Output 30A Evaluation Board     |                             |                             |                |
| ISL8225MEVAL4Z              | Dual 15A/optional 30A Cascadable Evaluation Board |                             |                             |                |

### NOTES:

1. Please refer to [TB347](#) for details on reel specifications.
2. These Intersil plastic packaged products are RoHS compliant by EU exemption 7C-I and employ special Pb-free material sets, molding compounds/die attach materials, and 100% matte tin plate plus anneal (e3) termination finish which is compatible with both SnPb and Pb-free soldering operations. Intersil RoHS compliant products are MSL classified at Pb-free peak reflow temperatures that meet or exceed the Pb-free requirements of IPC/JEDEC J STD-020.
3. For Moisture Sensitivity Level (MSL), please see device information page for [ISL8225M](#). For more information on MSL, please see tech brief [TB363](#)
4. The ISL8225M is guaranteed over the full -40 °C to +125 °C internal junction temperature range. Note that the allowed ambient temperature consistent with these specifications is determined by specific operating conditions, including board layout, cooling scheme and other environmental factors.

# Pin Configuration

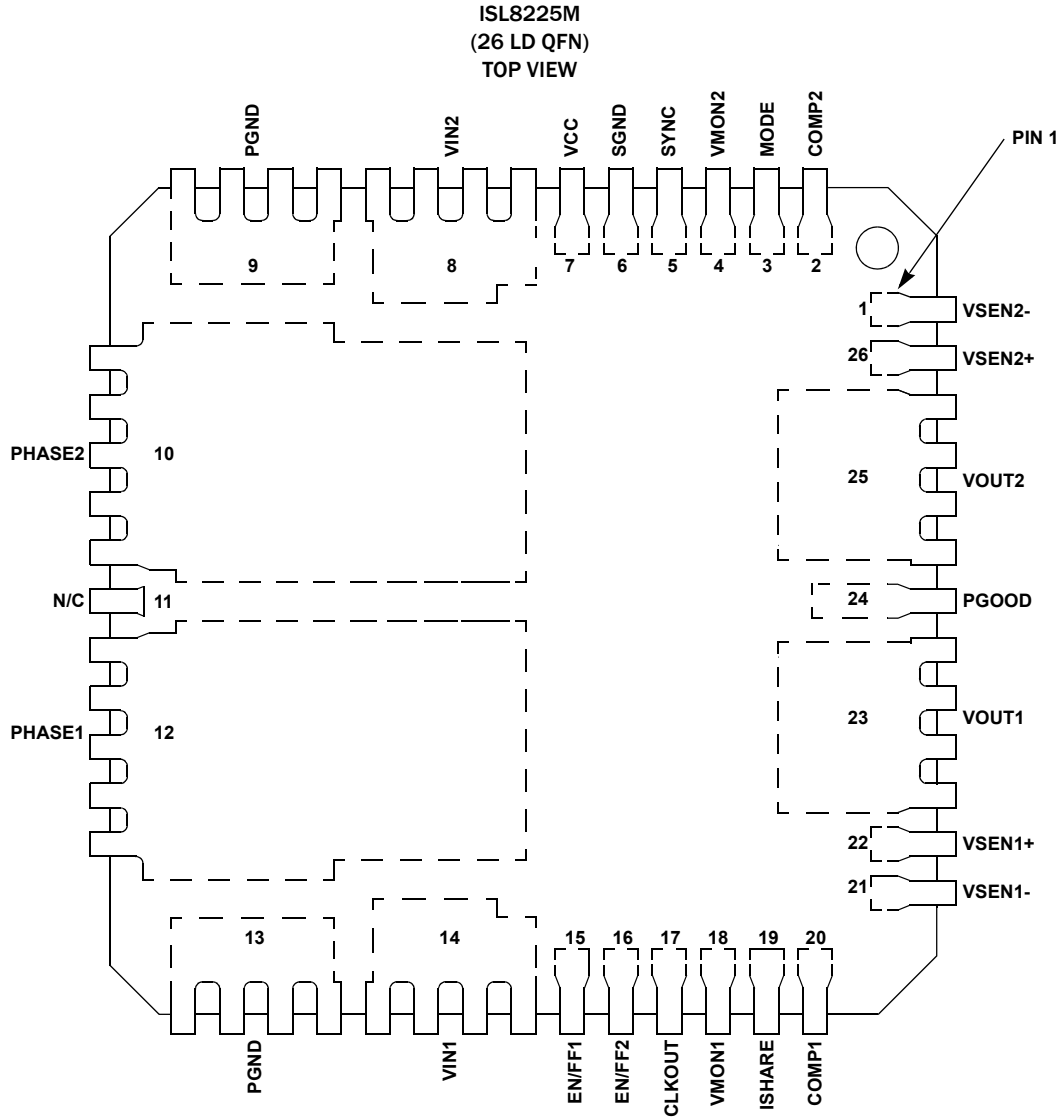

## Pin Descriptions

| PIN#   | PIN NAME       | TYPE | DESCRIPTION   |
|--------|----------------|------|---|
| 21, 1  | VSEN1-, VSEN2- | I    | <b>Output voltage negative feedback.</b> Negative input of the differential remote sense for the regulator. Connect to the negative rail or ground of the load/processor, as shown in <a href="#">Figure 19</a> . The negative feedback pins can be used to program the module operation conditions. See <a href="#">Tables 3</a> and <a href="#">5</a> for details.  |
| 20, 2  | COMP1, COMP2   | I/O  | <b>Error amplifier outputs.</b> Typically floating for dual-output use. For parallel use, a 470pF~1nF capacitor is recommended on the COMP pins of each SLAVE phase to eliminate the coupling noise. All COMP pins of SLAVE phases need to tie to MASTER phase COMP1 pin (first phase). Internal compensation networks are implemented for working in the full range of I/O conditions.   |
| 3      | MODE           | I    | <b>Mode setting.</b> Typically floating for dual-output use; tie to SGND for parallel use. See <a href="#">Tables 3</a> and <a href="#">5</a> for details. When VSEN2- is pulled within 700mV of VCC, the 2nd channel's remote sensing amplifier is disabled. The MODE pin, as well as the VSEN2+ pin, determine relative phase-shift between the two channels and the CLKOUT signal output.  |
| 18, 4  | VMON1, VMON2   | I/O  | <b>Remote sensing amplifier outputs.</b> These pins are connected internally to OV/UV/PGOOD comparators, so they can't be floated when the module works in multi-phase operation. When VSEN1-, VSEN2- are pulled within 700mV of VCC, the corresponding remote sensing amplifier is disabled; the output (VMON pin) is in high impedance. In this event, the VMON pins can be used as an additional monitor of the output voltage, with a resistor divider to protect the system against single point of failure. The default setting voltage is 0.6V. See <a href="#">Table 3</a> for details.   |
| 5      | SYNC           | I    | <b>Signal synchronization.</b> An optional external resistor ( $R_{SYNC}$ ) connected from this pin to SGND increases oscillator switching frequency ( <a href="#">Figure 33</a> and <a href="#">Table 1</a> ). The internal default frequency is 500kHz with this pin floating. Also, the internal oscillator can lock to an external frequency source or the CLKOUT signal from another ISL8225M. Input voltage range for external source: 3V to 5V square wave. No capacitor is recommended on this pin.   |
| 6      | SGND           | PWR  | <b>Control signal ground.</b> Connect to PGND under the module in the quiet inner layer. Make sure to have the single location for the connection between SGND and PGND to avoid noise coupling. See " <a href="#">Layout Guide</a> " on <a href="#">page 27</a> .  |
| 7      | VCC            | PWR  | <b>5V internal linear regulator output.</b> Voltage range: 3V to 5.6V. The decoupling ceramic capacitor for the VCC pin is recommended to be 4.7 $\mu$ F.   |
| 14, 8  | VIN1, VIN2     | PWR  | <b>Power inputs.</b> Input voltage range: 4.5V to 20V. Tie directly to the input rail. VIN1 provides power to the internal linear drive circuitry. When the input is 4.5V to 5.5V, VIN should be tied directly to VCC.  |
| 9, 13  | PGND           | PWR  | <b>Power ground.</b> Power ground pins for both input and output returns.   |
| 12, 10 | PHASE1, PHASE2 | PWR  | <b>Phase node.</b> Use for monitoring switching frequency. Phase pins should be floating or used for snubber connections. To achieve better thermal performance, the phase planes can also be used for heat removal with thermal vias connected to large inner layers. See " <a href="#">Layout Guide</a> " on <a href="#">page 27</a> .  |
| 11     | N/C            | -    | <b>Non-connection pin.</b> This pin is floating with no connection inside.  |
| 15, 16 | EN/FF1, EN/FF2 | I/O  | <b>Enable and feed-forward control.</b> Tie a resistor divider to VIN or use the system enable signal for this pin. The voltage turn-on threshold is 0.8V. With a voltage lower than the threshold, the corresponding channel can be disabled independently. By connecting to VIN with a resistor divider, the input voltage can be monitored for UVLO (undervoltage lockout) function. The voltage on each EN/FF pin is also used to adjust the internal control loop gain independently to realize the feed-forward function. Please set the EN/FF between 1.25V to 5V. A 1nF capacitor is recommended on each EN/FF pin. Please see <a href="#">Table 1</a> to select resistor divider and application details in " <a href="#">EN/FF Turn ON/OFF</a> " on <a href="#">page 23</a> . |
| 17     | CLKOUT         | I/O  | <b>Clock out.</b> Provide the clock signal for the input synchronization signal of other ISL8225Ms. Typically tied to VCC for dual-output use with 180° phase-shift. See <a href="#">Tables 3</a> and <a href="#">5</a> when using more than one ISL8225M. When the module is in dual-output mode, the clock-out signal is disabled. By programming the voltage level of this CLKOUT pin, the module can work for DDR/tracking or as two independent outputs with selectable phase-shift (see <a href="#">Table 6</a> ).  |
| 19     | ISHARE         | O    | <b>Current sharing control.</b> Tie all ISHARE pins together when multiple modules are configured for current sharing and share a common current output. The ISHARE voltage represents the average current of all active and connected channels. A 470pF capacitor is recommended for each ISHARE pin for multiple phase applications. Typically, the ISHARE pin should be floating for dual-output or single module application.   |
| 22, 26 | VSEN1+, VSEN2+ | I    | <b>Output voltage positive feedback.</b> Positive inputs of differential remote sense for the regulator. A resistor divider can be connected to this pin to program the output voltage. It is recommended to put the resistor divider close to the module and connect the kelvin sensing traces of VOUT and VSEN- to the sensing points of the load/processor (see <a href="#">Figure 19</a> ). The VSEN2+ pin can be used to program the module operation conditions. See <a href="#">Tables 3</a> and <a href="#">5</a> for details.  |
| 23, 25 | VOUT1, VOUT2   | PWR  | <b>Power Output.</b> Apply output load between these pins and PGND pins. Output voltage range: 0.6V to 7.5V.  |
| 24     | PGOOD          | O    | <b>Power good.</b> Provide open-drain power-good signal when the output is within 9% of the nominal output regulation point with 4% hysteresis (13%/9%) and soft-start complete. PGOOD monitors the outputs (VMON) of the internal differential amplifiers.   |

## Absolute Maximum Ratings

|  |                          |
|--|--------------------------|
| Input Voltage, $V_{IN}$                          | -0.3V to +25V            |
| Driver Bias Voltage, $V_{CC}$                    | -0.3V to +6.5V           |
| Phase Voltage, $V_{PHASE}$                       | -0.3V to +30V            |
| Input, Output or I/O Control Voltage             | -0.3V to $V_{CC} + 0.3V$ |
| ESD Rating                                       |                          |
| Human Body Model (Tested per JESD22-A114E)       | 2kV                      |
| Machine Model (Tested per JESD22-A115-A)         | 200V                     |
| Charge Device Model (Tested per JESD22-C101C)    | 750V                     |
| Latch-up (Tested per JESD-78B; Class 2, Level A) | 100mA                    |

## Thermal Information

|                                   |                                     |                                 |
|-----------------------------------|-------------------------------------|---------------------------------|
| Thermal Resistance (Typical)      | $\theta_{JA}$ ( $^{\circ}C/W$ )     | $\theta_{JC}$ ( $^{\circ}C/W$ ) |
| QFN Package (Notes 5, 6)          | 10.0                                | 0.9                             |
| Maximum Storage Temperature Range | -55 $^{\circ}C$ to +150 $^{\circ}C$ |                                 |
| Pb-free Reflow Profile            | Refer to <a href="#">Figure 48</a>  |                                 |

## Recommended Operating Conditions

|   |                                     |
|---|-------------------------------------|
| Input Voltage, $V_{IN1}$ and $V_{IN2}$    | 4.5V to 20.0V                       |
| Output Voltage, $V_{OUT1}$ and $V_{OUT2}$ | 0.6V to 7.5V                        |
| Junction Temperature Range                | -40 $^{\circ}C$ to +125 $^{\circ}C$ |

**CAUTION:** Do not operate at or near the maximum ratings listed for extended periods of time. Exposure to such conditions may adversely impact product reliability and result in failures not covered by warranty.

### NOTES:

- $\theta_{JA}$  is measured in free air with the component mounted on a high effective thermal conductivity test board with “direct attach” features. See Tech Brief [TB379](#).
- For  $\theta_{JC}$ , the “case temp” location is the center of the phase exposed metal pad on the package underside.

## Electrical Specifications $T_A = +25^{\circ}C$ , $V_{IN} = 12V$ , unless otherwise noted. Boldface limits apply across the internal junction temperature range, -40 $^{\circ}C$ to +125 $^{\circ}C$ (Note 4).

| PARAMETER                                 | SYMBOL         | TEST CONDITIONS  | MIN<br>(Note 7) | TYP<br>(Note 8) | MAX<br>(Note 7) | UNITS    |
|---|----------------|--|-----------------|-----------------|-----------------|----------|
| <b>VCC SUPPLY CURRENT</b>                 |                |  |                 |                 |                 |          |
| Nominal Supply $V_{IN}$ Current           | $I_{Q\_VIN}$   | $V_{IN} = 20V$ ; no load; EN1 = EN2 = high   |                 | 131             |                 | mA       |
|   |                | $V_{IN1} = 20V$ ; no load; EN1 = high, EN2 = low   |                 | 72              |                 | mA       |
|   |                | $V_{IN2} = 20V$ ; no load; EN1 = 0, EN2 = high   |                 | 71              |                 | mA       |
|   |                | $V_{IN1} = 12V$ ; no load; EN1 = high, EN2 = high  |                 | 134             |                 | mA       |
|   |                | $V_{IN} = 4.5V$ ; no load; EN1 = EN2 = high  |                 | 136             |                 | mA       |
|   |                | $V_{IN1} = 4.5V$ ; no load; EN1 = high, EN2 = low  |                 | 73              |                 | mA       |
|   |                | $V_{IN2} = 4.5V$ ; no load; EN1 = 0, EN2 = high  |                 | 70              |                 | mA       |
| <b>INTERNAL LINEAR REGULATOR (Note 9)</b> |                |  |                 |                 |                 |          |
| Maximum Current                           | $I_{PVCC}$     | $V_{CC} = 4V$ to 5.6V  |                 | 250             |                 | mA       |
| Saturated Equivalent Impedance            | $R_{LDO}$      | P-Channel MOSFET ( $V_{IN} = 5V$ )   |                 | 1               |                 | $\Omega$ |
| $V_{CC}$ Voltage Level                    | $V_{CC}$       | $I_{VCC} = 0mA$  | <b>5.1</b>      | 5.4             | <b>5.6</b>      | V        |
| <b>POWER-ON RESET (Note 9)</b>            |                |  |                 |                 |                 |          |
| Rising $V_{CC}$ Threshold                 |                | 0 $^{\circ}C$ to +75 $^{\circ}C$   |                 | 2.85            | 2.97            | V        |
|   |                | -40 $^{\circ}C$ to +85 $^{\circ}C$   |                 | 2.85            | <b>3.05</b>     | V        |
| Falling $V_{CC}$ Threshold                |                |  |                 | 2.65            | <b>2.75</b>     | V        |
| System Soft-start Delay                   | $t_{SS\_DLY}$  | After PLL and $V_{CC}$ PORs, and EN above their thresholds                                     |                 | 384             |                 | Cycles   |
| <b>ENABLE (Note 9)</b>                    |                |  |                 |                 |                 |          |
| Turn-on Threshold Voltage                 |                |  | <b>0.75</b>     | 0.8             | <b>0.86</b>     | V        |
| Hysteresis Sink Current                   | $I_{EN\_HYS}$  |  | <b>23</b>       | 30              | <b>35</b>       | $\mu A$  |
| Undervoltage Lockout Hysteresis           | $V_{EN\_HYS}$  | $V_{EN\_RTH} = 10.6V$ ; $V_{EN\_FTH} = 9V$ , $R_{UP} = 53.6k\Omega$ , $R_{DOWN} = 5.23k\Omega$ |                 | 1.6             |                 | V        |
| Sink Current                              | $I_{EN\_SINK}$ | $V_{ENFF} = 1V$  | <b>15.4</b>     |                 |                 | mA       |
| Sink Impedance                            | $R_{EN\_SINK}$ | $I_{EN\_SINK} = 5mA$ , $V_{ENFF} = 1V$   |                 |                 | <b>64</b>       | $\Omega$ |

**Electrical Specifications**  $T_A = +25^\circ\text{C}$ ,  $V_{IN} = 12\text{V}$ , unless otherwise noted. **Boldface limits apply across the internal junction temperature range,  $-40^\circ\text{C}$  to  $+125^\circ\text{C}$  (Note 4).** (Continued)

| PARAMETER  | SYMBOL                         | TEST CONDITIONS  | MIN<br>(Note 7) | TYP<br>(Note 8) | MAX<br>(Note 7) | UNITS             |
|--|--------------------------------|--|-----------------|-----------------|-----------------|-------------------|
| <b>OSCILLATOR</b>  |                                |  |                 |                 |                 |                   |
| Oscillator Frequency   | $f_{OSC}$                      | SYNC pin is open   |                 | 510             |                 | kHz               |
| Total Variation (Note 9)   |                                | $V_{CC} = 5\text{V}; -40^\circ\text{C} < T_A < +85^\circ\text{C}$  | <b>-9</b>       |                 | <b>+9</b>       | %                 |
| <b>FREQUENCY SYNCHRONIZATION AND PHASE LOCK LOOP (Note 9)</b>        |                                |  |                 |                 |                 |                   |
| Synchronization Frequency  |                                | $V_{CC} = 5\text{V}$   | <b>300</b>      |                 | <b>1500</b>     | kHz               |
| PLL Locking Time   |                                | $V_{CC} = 5.4\text{V}, f_{SW} = 500\text{kHz}$   |                 | 130             |                 | $\mu\text{s}$     |
| Input Signal Duty Cycle Range  |                                |  | <b>10</b>       |                 | <b>90</b>       | %                 |
| <b>PWM (Note 9)</b>  |                                |  |                 |                 |                 |                   |
| Minimum PWM OFF Time   | $t_{MIN\_OFF}$                 |  | <b>310</b>      | 345             | <b>410</b>      | ns                |
| Current Sampling Blanking Time                                       | $t_{BLANKING}$                 |  |                 | 175             |                 | ns                |
| <b>OUTPUT CHARACTERISTICS</b>  |                                |  |                 |                 |                 |                   |
| Output Continuous Current Range                                      | $I_{OUT(DC)}$                  | $V_{IN} = 12\text{V}, V_{OUT1} = 1.5\text{V}$  | <b>0</b>        |                 | <b>15</b>       | A                 |
|  |                                | $V_{IN} = 12\text{V}, V_{OUT2} = 1.5\text{V}$  | <b>0</b>        |                 | <b>15</b>       | A                 |
|  |                                | $V_{IN} = 12\text{V}, V_{OUT} = 1.5\text{V}$ , in Parallel mode  | <b>0</b>        |                 | <b>30</b>       | A                 |
| Line Regulation Accuracy   | $\Delta V_{OUT}/\Delta V_{IN}$ | $V_{IN} = 4.5\text{V to } 20\text{V}$<br>$V_{OUT1} = 1.5\text{V}, I_{OUT1} = 0\text{A}$<br>$V_{OUT2} = 1.5\text{V}, I_{OUT2} = 0\text{A}$  |                 | 0.0065          |                 | %                 |
|  |                                | $V_{IN} = 4.5\text{V to } 20\text{V}$<br>$V_{OUT1} = 1.5\text{V}, I_{OUT1} = 15\text{A}$<br>$V_{OUT2} = 1.5\text{V}, I_{OUT2} = 15\text{A}$  |                 | 0.01            |                 | %                 |
|  |                                | $V_{IN} = 4.5\text{V to } 20\text{V}$<br>$V_{OUT1} = 1.5\text{V}, I_{OUT1} = 15\text{A}$<br>$V_{OUT2} = 1.5\text{V}, I_{OUT2} = 15\text{A}$  |                 | 0.01            |                 | %                 |
|  |                                | $V_{IN} = 4.5\text{V to } 20\text{V}$<br>$V_{OUT1} = 1.5\text{V}, I_{OUT1} = 15\text{A}$<br>$V_{OUT2} = 1.5\text{V}, I_{OUT2} = 15\text{A}$  |                 | 0.01            |                 | %                 |
| Load Regulation Accuracy   | $\Delta V_{OUT}/V_{OUT}$       | $V_{IN} = 12\text{V}, 5 \times 22\mu\text{F}$ ceramic capacitor and $1 \times 330\mu\text{F}$ POSCAP<br>$I_{OUT1} = 0\text{A to } 15\text{A}, V_{OUT1} = 1.5\text{V}$<br>$I_{OUT2} = 0\text{A to } 15\text{A}, V_{OUT2} = 1.5\text{V}$                           |                 | 0.3             | <b>1</b>        | %                 |
|  |                                | $V_{IN} = 12\text{V}, 5 \times 22\mu\text{F}$ ceramic capacitor and $1 \times 330\mu\text{F}$ POSCAP<br>$I_{OUT1} = 0\text{A to } 15\text{A}, V_{OUT1} = 1.5\text{V}$<br>$I_{OUT2} = 0\text{A to } 15\text{A}, V_{OUT2} = 1.5\text{V}$                           |                 | 0.3             | <b>1</b>        | %                 |
| Output Ripple Voltage  | $\Delta V_{OUT}$               | $V_{IN} = 12\text{V}, 3 \times 100\mu\text{F}$ ceramic capacitor and $1 \times 330\mu\text{F}$ POSCAP<br>$I_{OUT1} = 0\text{A}, V_{OUT1} = 1.5\text{V}$<br>$I_{OUT2} = 0\text{A}, V_{OUT2} = 1.5\text{V}$  |                 | 11              |                 | mV <sub>P-P</sub> |
|  |                                | $V_{IN} = 12\text{V}, 3 \times 100\mu\text{F}$ ceramic capacitor and $1 \times 330\mu\text{F}$ POSCAP<br>$I_{OUT1} = 0\text{A}, V_{OUT1} = 1.5\text{V}$<br>$I_{OUT2} = 0\text{A}, V_{OUT2} = 1.5\text{V}$  |                 | 11              |                 | mV <sub>P-P</sub> |
|  |                                | $V_{IN} = 12\text{V}, 3 \times 100\mu\text{F}$ ceramic capacitor and $1 \times 330\mu\text{F}$ POSCAP<br>$I_{OUT1} = 15\text{A}, V_{OUT1} = 1.5\text{V}$<br>$I_{OUT2} = 15\text{A}, V_{OUT2} = 1.5\text{V}$  |                 | 14              |                 | mV <sub>P-P</sub> |
|  |                                | $V_{IN} = 12\text{V}, 3 \times 100\mu\text{F}$ ceramic capacitor and $1 \times 330\mu\text{F}$ POSCAP<br>$I_{OUT1} = 15\text{A}, V_{OUT1} = 1.5\text{V}$<br>$I_{OUT2} = 15\text{A}, V_{OUT2} = 1.5\text{V}$  |                 | 14              |                 | mV <sub>P-P</sub> |
| <b>DYNAMIC CHARACTERISTICS</b>                                       |                                |  |                 |                 |                 |                   |
| Voltage Change for Positive Load Step                                | $\Delta V_{OUT-DP}$            | Current slew rate = $2.5\text{A}/\mu\text{s}$<br>$V_{IN} = 12\text{V}, V_{OUT} = 1.5\text{V}, 2 \times 47\mu\text{F}$ ceramic capacitor and $1 \times 330\mu\text{F}$ POSCAP<br>$I_{OUT1} = 0\text{A to } 7.5\text{A}$<br>$I_{OUT2} = 0\text{A to } 7.5\text{A}$ |                 | 75              |                 | mV <sub>P-P</sub> |
|  |                                | Current slew rate = $2.5\text{A}/\mu\text{s}$<br>$V_{IN} = 12\text{V}, V_{OUT} = 1.5\text{V}, 2 \times 47\mu\text{F}$ ceramic capacitor and $1 \times 330\mu\text{F}$ POSCAP<br>$I_{OUT1} = 0\text{A to } 7.5\text{A}$<br>$I_{OUT2} = 0\text{A to } 7.5\text{A}$ |                 | 75              |                 | mV <sub>P-P</sub> |
| Voltage Change for Negative Load Step                                | $\Delta V_{OUT-DN}$            | Current slew rate = $2.5\text{A}/\mu\text{s}$<br>$V_{IN} = 12\text{V}, V_{OUT} = 1.5\text{V}, 2 \times 47\mu\text{F}$ ceramic capacitor and $1 \times 330\mu\text{F}$ POSCAP<br>$I_{OUT1} = 7.5\text{A to } 0\text{A}$<br>$I_{OUT2} = 7.5\text{A to } 0\text{A}$ |                 | 70              |                 | mV <sub>P-P</sub> |
|  |                                | Current slew rate = $2.5\text{A}/\mu\text{s}$<br>$V_{IN} = 12\text{V}, V_{OUT} = 1.5\text{V}, 2 \times 47\mu\text{F}$ ceramic capacitor and $1 \times 330\mu\text{F}$ POSCAP<br>$I_{OUT1} = 7.5\text{A to } 0\text{A}$<br>$I_{OUT2} = 7.5\text{A to } 0\text{A}$ |                 | 70              |                 | mV <sub>P-P</sub> |
| <b>REFERENCE (Note 9)</b>  |                                |  |                 |                 |                 |                   |
| Reference Voltage (Include Error and Differential Amplifier Offsets) | $V_{REF1}$                     | $T_A = -40^\circ\text{C to } +85^\circ\text{C}$  | <b>0.5958</b>   | 0.6             | <b>0.6042</b>   | V                 |
|  |                                |  | <b>-0.7</b>     |                 | <b>0.7</b>      | %                 |
| Reference Voltage (Include Error and Differential Amplifier Offsets) | $V_{REF2}$                     | $T_A = -40^\circ\text{C to } +85^\circ\text{C}$  | <b>0.5955</b>   | 0.6             | <b>0.6057</b>   | V                 |
|  |                                |  | <b>-0.75</b>    |                 | <b>0.95</b>     | %                 |



**Electrical Specifications**  $T_A = +25^\circ\text{C}$ ,  $V_{IN} = 12\text{V}$ , unless otherwise noted. **Boldface limits apply across the internal junction temperature range,  $-40^\circ\text{C}$  to  $+125^\circ\text{C}$  (Note 4).** (Continued)

| PARAMETER  | SYMBOL                      | TEST CONDITIONS  | MIN<br>(Note 7) | TYP<br>(Note 8)       | MAX<br>(Note 7)             | UNITS |
|--|-----------------------------|--|-----------------|-----------------------|-----------------------------|-------|
| <b>DIFFERENTIAL AMPLIFIER (Note 9)</b>                               |                             |  |                 |                       |                             |       |
| DC Gain  | UG_DA                       | Unity gain amplifier   |                 | 0                     |                             | dB    |
| Unity Gain Bandwidth   | UGBW_DA                     |  |                 | 5                     |                             | MHz   |
| VSEN+ Pin Sourcing Current   | I <sub>VSEN+</sub>          |  | <b>0.2</b>      | 1                     | <b>2.5</b>                  | μA    |
| Maximum Source Current for Current Sharing                           | I <sub>VSEN1-</sub>         | VSEN1- Source Current for Current Sharing when parallel multiple modules, each of which has its own voltage loop |                 | 350                   |                             | μA    |
| Input Impedance  | R <sub>VSEN+_to_VSEN-</sub> | V <sub>VSEN+</sub> /I <sub>VSEN+</sub> , V <sub>VSEN+</sub> = 0.6V   |                 | -600                  |                             | kΩ    |
| Output Voltage Swing   |                             |  | <b>0</b>        |                       | <b>V<sub>CC</sub> - 1.8</b> | V     |
| Input Common Mode Range  |                             |  | <b>-0.2</b>     |                       | <b>V<sub>CC</sub> - 1.8</b> | V     |
| Disable Threshold  | V <sub>VSEN-</sub>          | V <sub>MON1, 2</sub> = tri-state   |                 | V <sub>CC</sub> - 0.4 |                             | V     |
| <b>OVERCURRENT PROTECTION (Note 9)</b>                               |                             |  |                 |                       |                             |       |
| Channel Overcurrent Limit  | I <sub>limit1</sub>         | V <sub>IN</sub> = 12V, V <sub>OUT1</sub> = 1.5V, R <sub>SYNC</sub> = Open  |                 | 20                    |                             | A     |
|  | I <sub>limit2</sub>         | V <sub>IN</sub> = 12V, V <sub>OUT2</sub> = 1.5V, R <sub>SYNC</sub> = Open  |                 | 20                    |                             | A     |
| Share Pin OC Threshold   | V <sub>OC_SET</sub>         | V <sub>CC</sub> = 5V<br>(comparator offset included)   | <b>1.16</b>     | 1.20                  | <b>1.22</b>                 | V     |
| <b>CURRENT SHARE</b>   |                             |  |                 |                       |                             |       |
| Current Share Accuracy   | ΔI/I <sub>OUT</sub>         | V <sub>IN</sub> = 12V, V <sub>OUT</sub> = 1.5V<br>I <sub>OUT</sub> = 30A, V <sub>SEN2-</sub> = high              |                 | ±10                   |                             | %     |
| <b>POWER-GOOD MONITOR (Note 9)</b>                                   |                             |  |                 |                       |                             |       |
| Undervoltage Falling Trip Point                                      | V <sub>UVF</sub>            | Percentage below reference point   | <b>-15</b>      | -13                   | <b>-11</b>                  | %     |
| Undervoltage Rising Hysteresis                                       | V <sub>UVR_HYS</sub>        | Percentage above UV trip point   |                 | 4                     |                             | %     |
| Overvoltage Rising Trip Point  | V <sub>OVR</sub>            | Percentage above reference point   | <b>11</b>       | 13                    | <b>15</b>                   | %     |
| Overvoltage Falling Hysteresis                                       | V <sub>OVF_HYS</sub>        | Percentage below OV trip point   |                 | 4                     |                             | %     |
| PGOOD Low Output Voltage   |                             | I <sub>PGOOD</sub> = 2mA   |                 |                       | <b>0.35</b>                 | V     |
| Sinking Impedance  |                             | I <sub>PGOOD</sub> = 2mA   |                 |                       | <b>70</b>                   | Ω     |
| Maximum Sinking Current  |                             | V <sub>PGOOD</sub> < 0.8V  |                 | 10                    |                             | mA    |
| <b>OVERVOLTAGE PROTECTION (Note 9)</b>                               |                             |  |                 |                       |                             |       |
| OV Latching-up Trip Point  |                             | EN/FF = UGATE = LATCH Low, LGATE = High  | <b>118</b>      | 120                   | <b>122</b>                  | %     |
| OV Non Latching-up Trip Point  |                             | EN = Low, UGATE = Low, LGATE = High  |                 | 113                   |                             | %     |
| LGATE Release Trip Point   |                             | EN = Low/HIGH, UGATE = Low, LGATE = Low  |                 | 87                    |                             | %     |
| <b>OVER-TEMPERATURE PROTECTION (Note 9)</b>                          |                             |  |                 |                       |                             |       |
| Over-Temperature Trip (Controller Junction Temperature)              |                             |  |                 | 150                   |                             | °C    |
| Over-Temperature Release Threshold (Controller Junction Temperature) |                             |  |                 | 125                   |                             | °C    |

## NOTES:

- Compliance to datasheet limits is assured by one or more methods: production test, characterization and/or design.
- Parameters with TYP limits are not production tested, unless otherwise specified.
- Parameters are 100% tested for internal IC prior to module assembly.

## Typical Performance Characteristics

**Efficiency Performance**  $T_A = +25^\circ\text{C}$ , if not specified, as shown in [Figure 18](#) with 2nd phase disabled. The efficiency equation is as follows:

$$\text{Efficiency} = \frac{\text{Output Power}}{\text{Input Power}} = \frac{P_{\text{OUT}}}{P_{\text{IN}}} = \frac{(V_{\text{OUT}} \times I_{\text{OUT}})}{(V_{\text{IN}} \times I_{\text{IN}})}$$

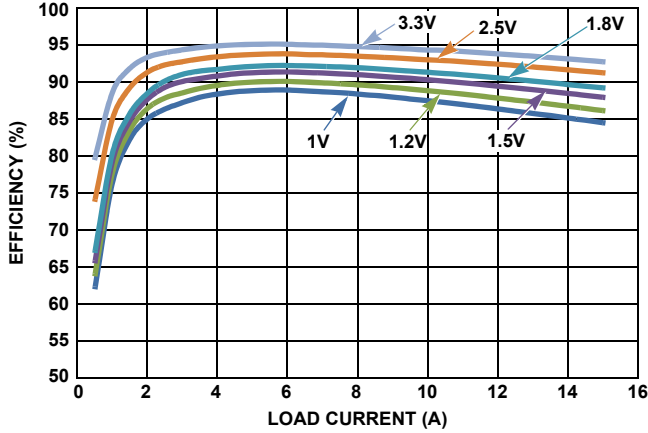

FIGURE 3. EFFICIENCY vs LOAD CURRENT ( $5V_{\text{IN}}$  AT 500kHz)

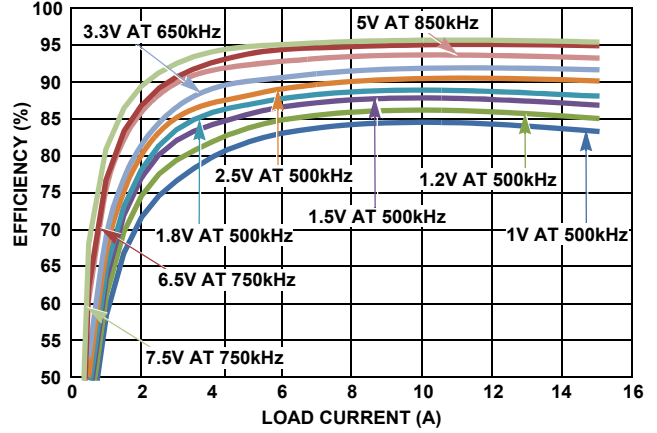

FIGURE 4. EFFICIENCY vs LOAD CURRENT ( $12V_{\text{IN}}$ )

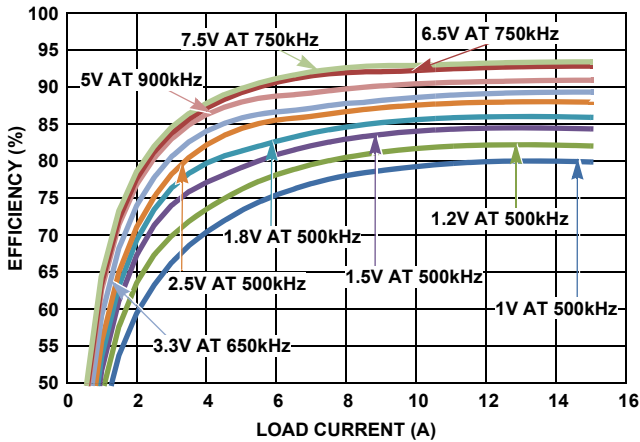

FIGURE 5. EFFICIENCY vs LOAD CURRENT ( $20V_{\text{IN}}$ )

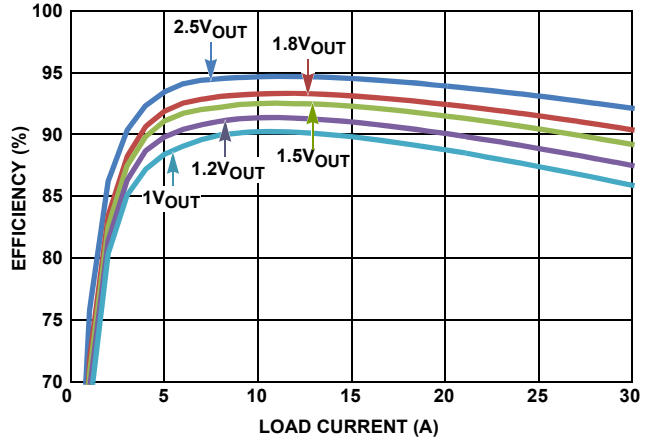

FIGURE 6. EFFICIENCY vs LOAD CURRENT (PARALLEL SINGLE OUTPUT, AS SHOWN IN [Figure 19](#) AT  $5V_{\text{IN}}/500\text{kHz}$ )

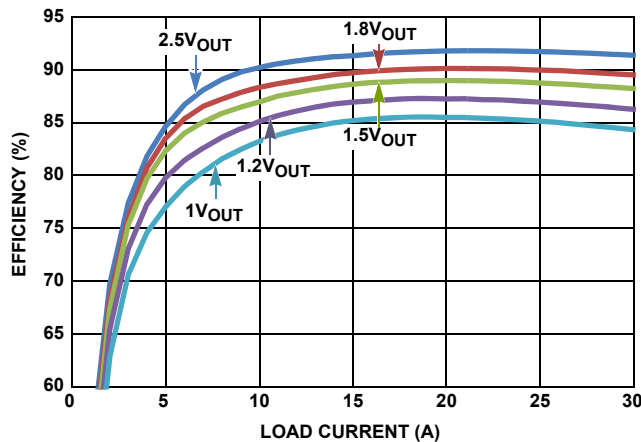

FIGURE 7. EFFICIENCY vs LOAD CURRENT (PARALLEL SINGLE OUTPUT, AS SHOWN IN [Figure 19](#) AT  $12V_{\text{IN}}/500\text{kHz}$ )

## Typical Performance Characteristics (Continued)

**Transient Response Performance**  $V_{IN} = 12V$ ,  $C_{OUT} = 1 \times 10\mu F$  and  $3 \times 100\mu F$  ceramic capacitors,  $I_{OUT} = 0A$  to  $7.5A$ , current slew rate =  $2.5A/\mu s$ .  $T_A = +25^\circ C$ , if not specified, as shown in [Figure 18](#) with 2nd phase disabled.

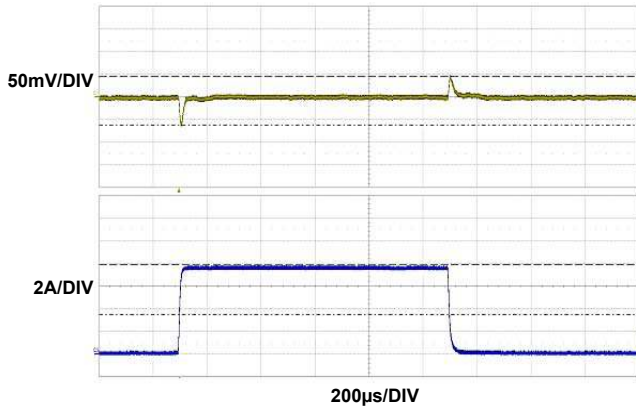

FIGURE 8. 1V<sub>OUT</sub> TRANSIENT RESPONSE

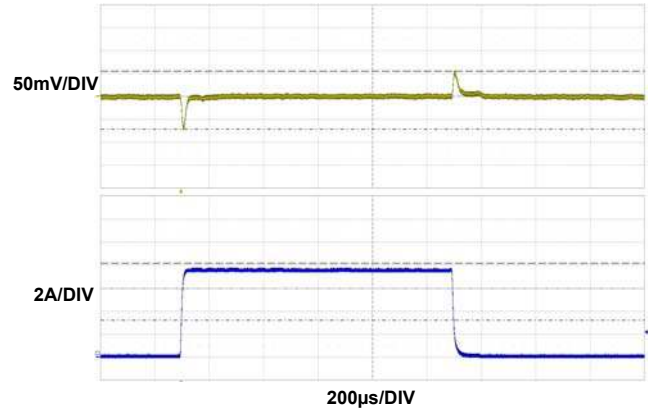

FIGURE 9. 1.2V<sub>OUT</sub> TRANSIENT RESPONSE

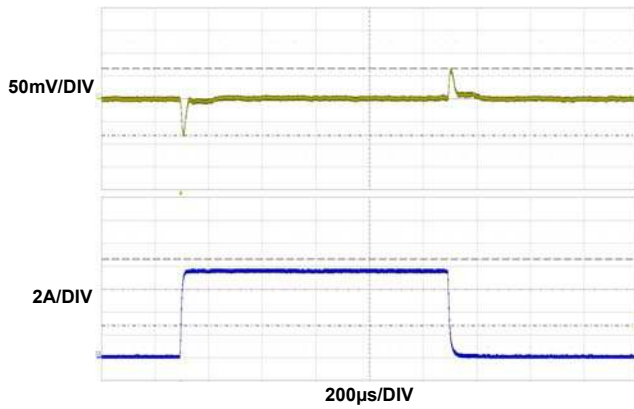

FIGURE 10. 1.5V<sub>OUT</sub> TRANSIENT RESPONSE

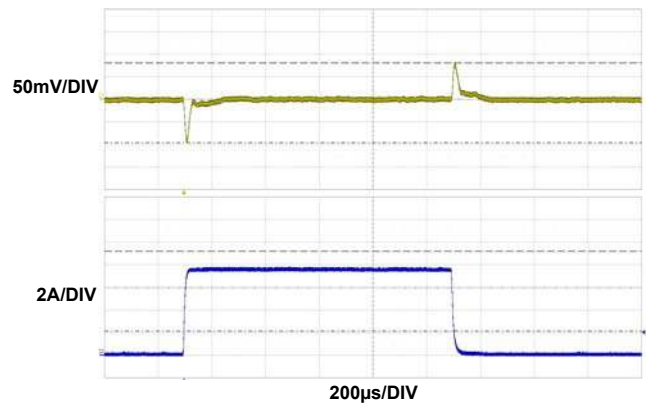

FIGURE 11. 1.8V<sub>OUT</sub> TRANSIENT RESPONSE

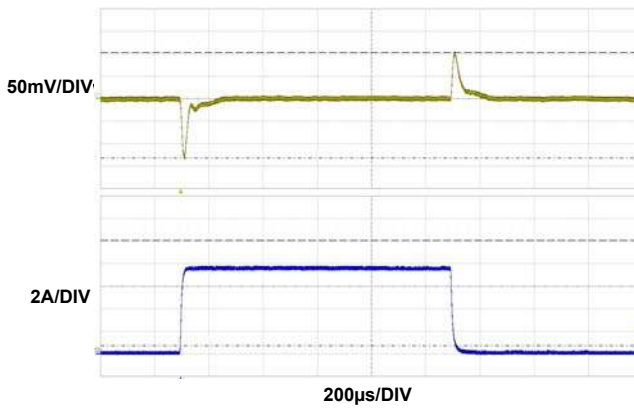

FIGURE 12. 2.5V<sub>OUT</sub> TRANSIENT RESPONSE

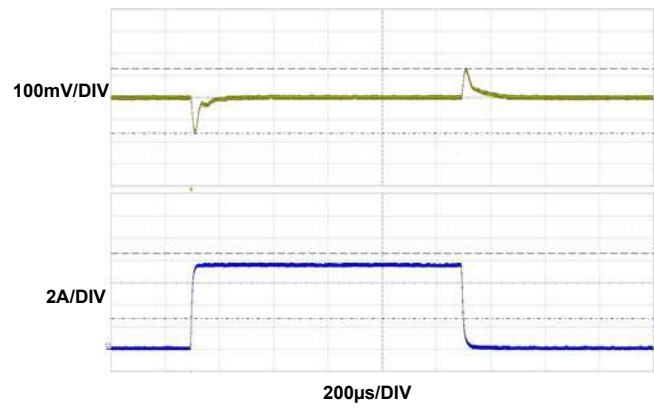

FIGURE 13. 3.3V<sub>OUT</sub> TRANSIENT RESPONSE

## Typical Performance Characteristics (Continued)

**Start-up and Short Circuit Performance**  $V_{IN} = 12V$ ,  $V_{OUT} = 1.5V$ ,  $C_{IN} = 1 \times 180\mu F$ ,  $2 \times 10\mu F$ /Ceramic,  $C_{OUT} = 2 \times 47\mu F$  and  $1 \times 330\mu F$  POSCAP.  $T_A = +25^\circ C$ , if not specified, as shown in [Figure 18](#) with 2nd phase disabled.

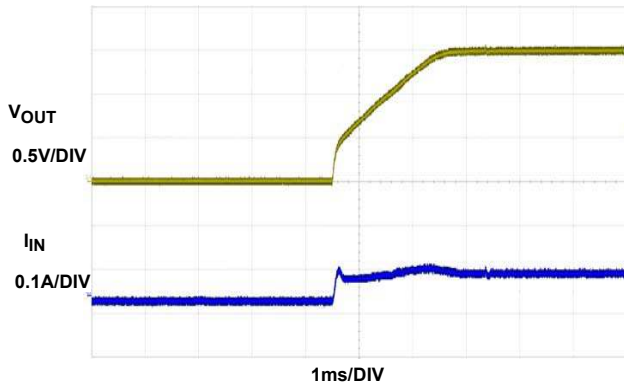

FIGURE 14. START-UP AT 0A

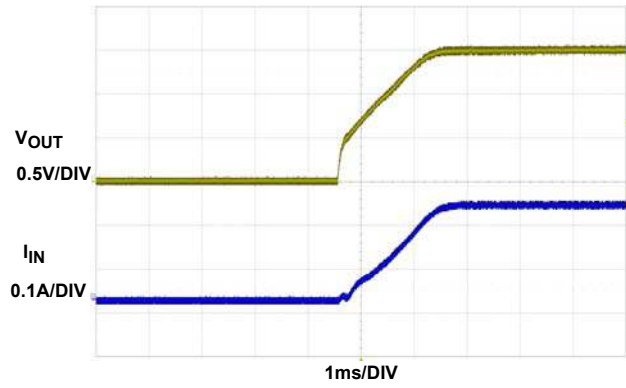

FIGURE 15. START-UP AT 15A

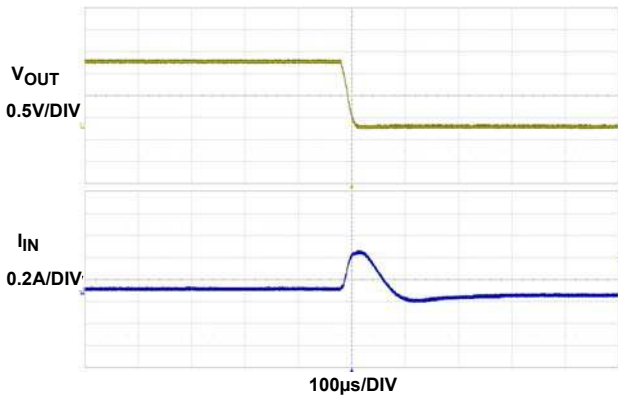

FIGURE 16. SHORT CIRCUIT AT 0A

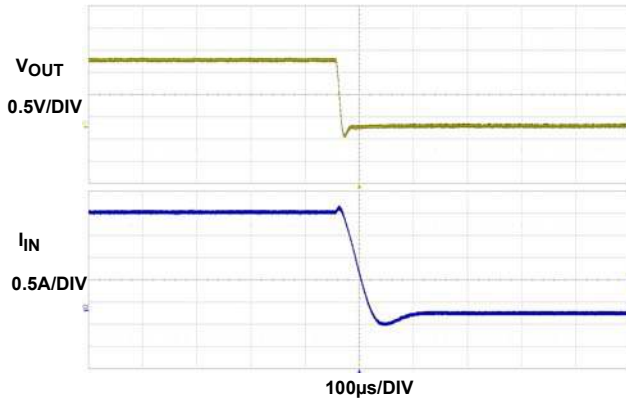
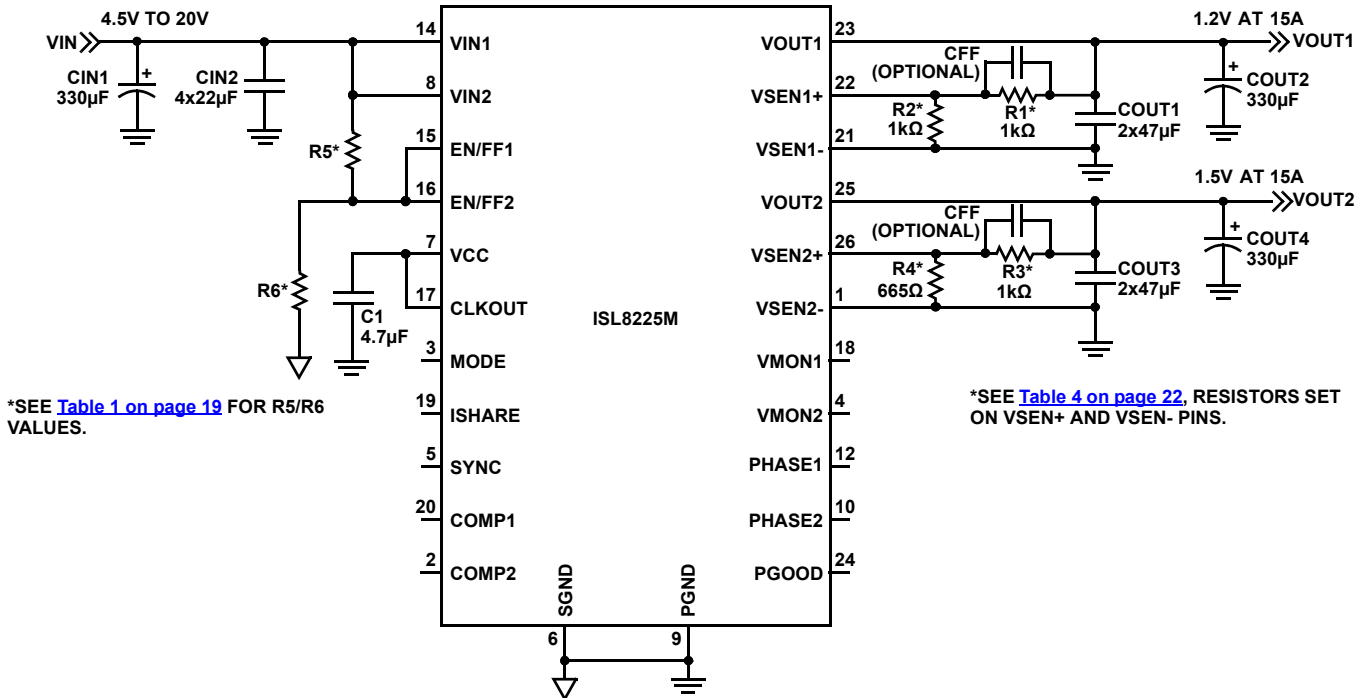

FIGURE 17. SHORT CIRCUIT AT 15A

# Typical Application Circuits



\*SEE Table 1 on page 19 FOR R5/R6 VALUES.

\*SEE Table 4 on page 22, RESISTORS SET ON VSEN+ AND VSEN- PINS.

SEE "LAYOUT GUIDE" ON PAGE 27 FOR SHORTING SGND TO PGND  
 FIGURE 18. DUAL OUTPUTS FOR 1.2V/15A AND 1.5V/15A

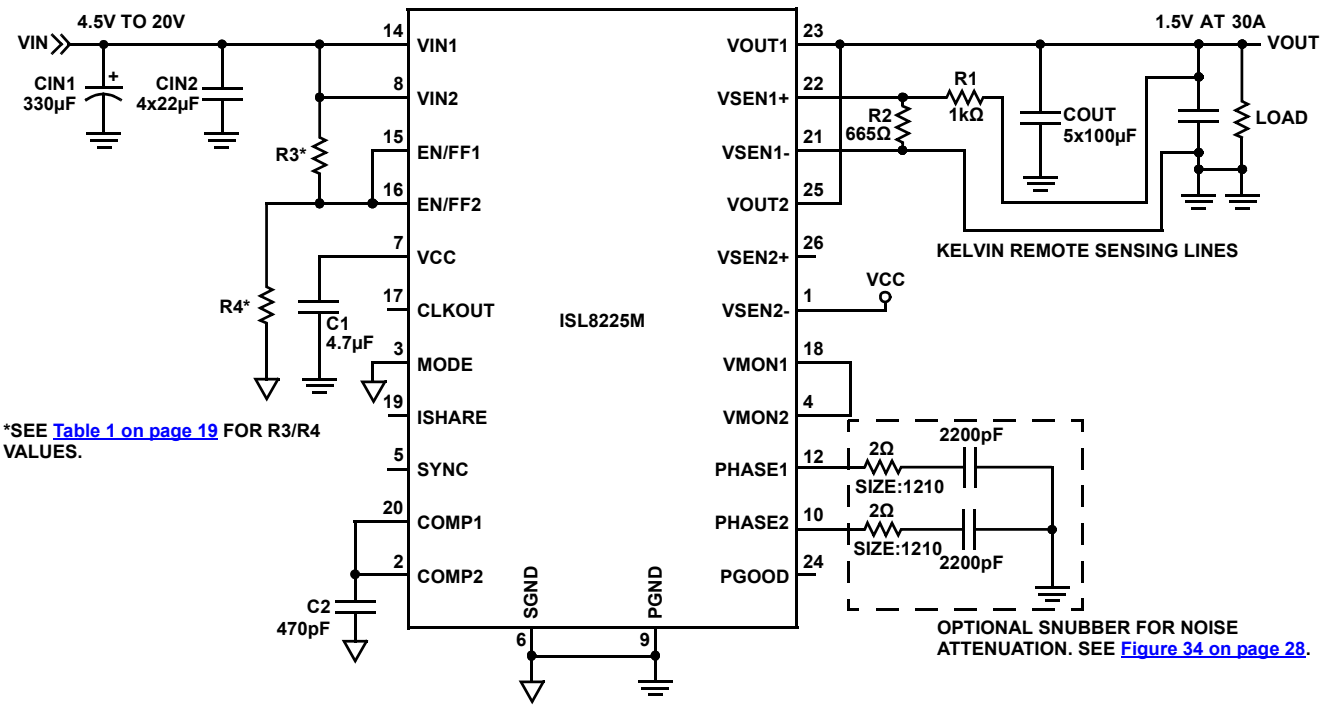

\*SEE Table 1 on page 19 FOR R3/R4 VALUES.

OPTIONAL SNUBBER FOR NOISE ATTENUATION. SEE Figure 34 on page 28.

SEE "LAYOUT GUIDE" ON PAGE 27 FOR SHORTING SGND TO PGND  
 FIGURE 19. PARALLEL USE FOR SINGLE 1.5V/30A OUTPUT WITH 180° INTERLEAVING

## Typical Application Circuits (Continued)

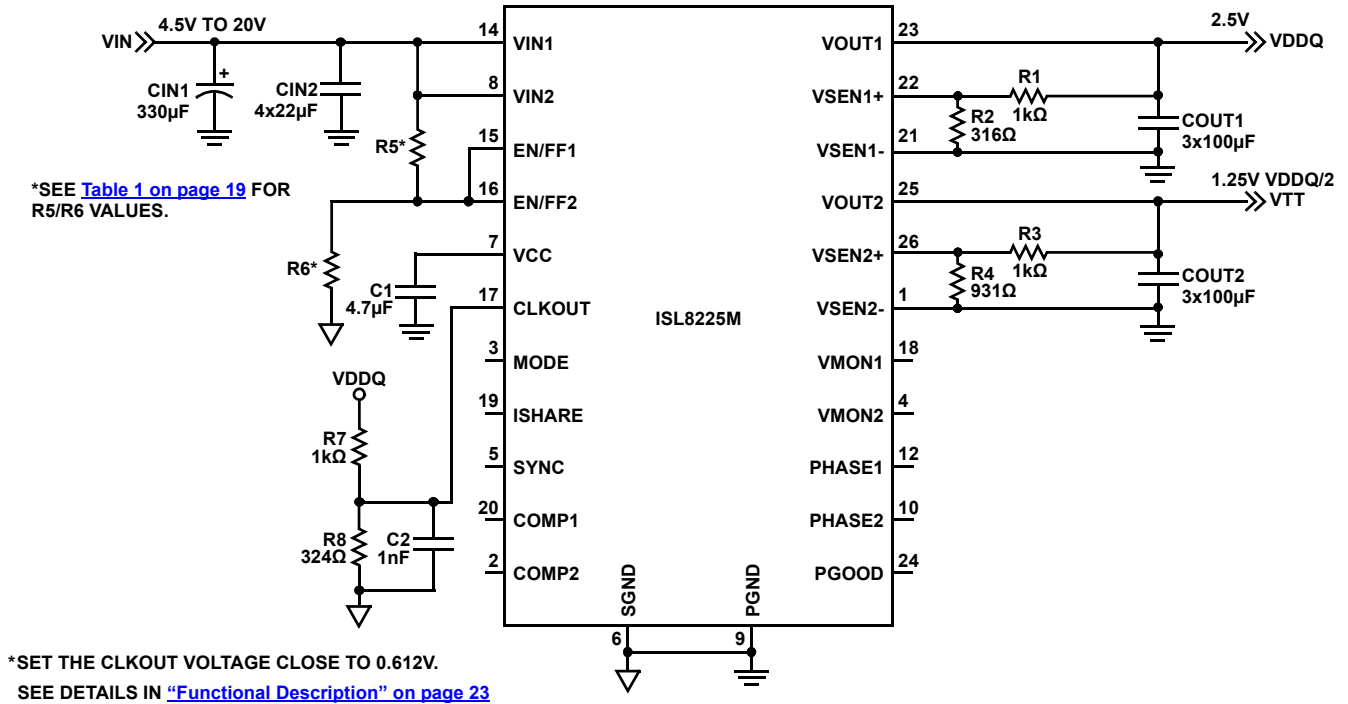

FIGURE 20. DDR/TRACKING USE

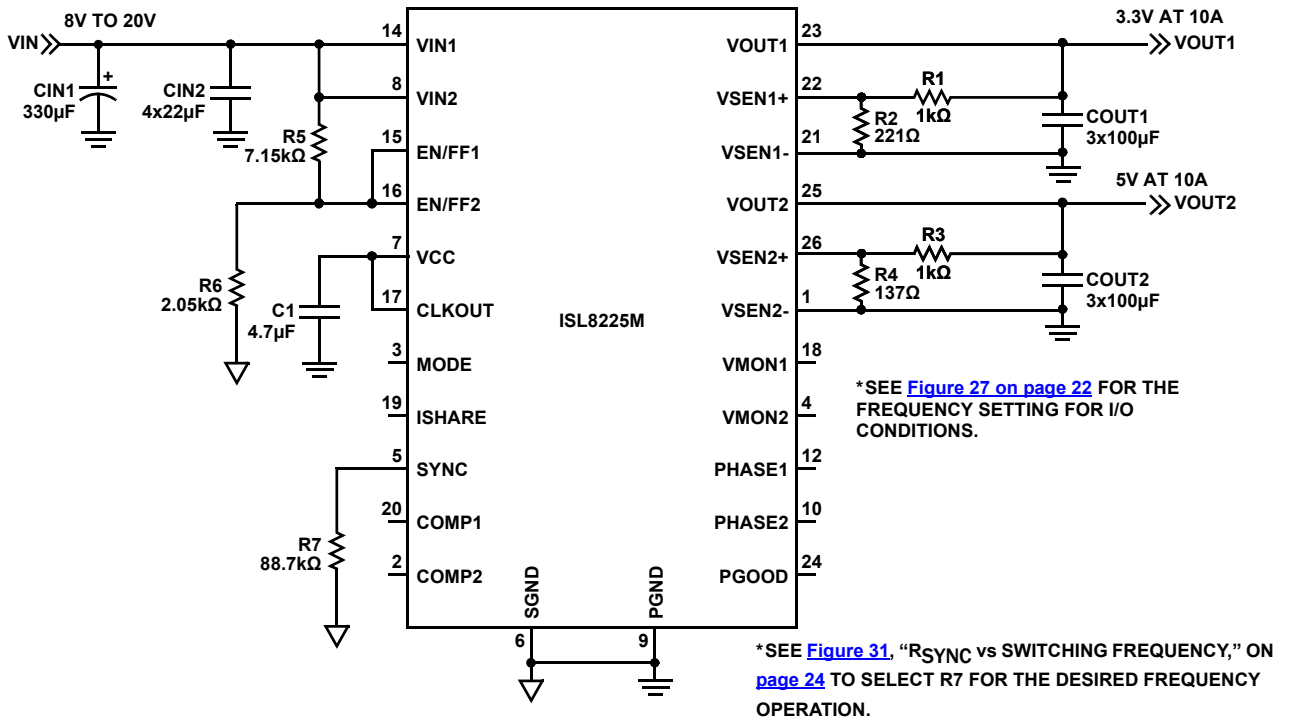
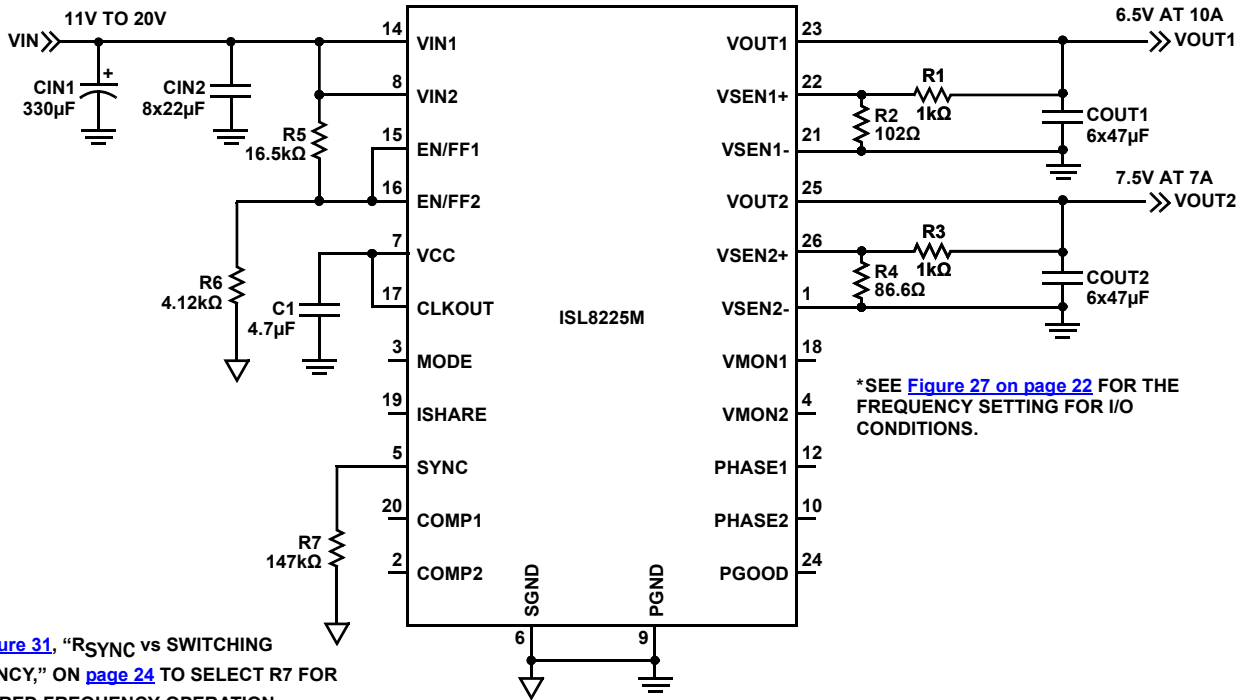

FIGURE 21. 3.3V/5V VOLTAGE APPLICATION WITH THE FREQUENCY SET AT 900kHz

# Typical Application Circuits (Continued)



\*SEE Figure 31, "RSYNC vs SWITCHING FREQUENCY," ON page 24 TO SELECT R7 FOR THE DESIRED FREQUENCY OPERATION.

FIGURE 22. HIGH OUTPUT VOLTAGE APPLICATION WITH THE FREQUENCY SET AT 750kHz

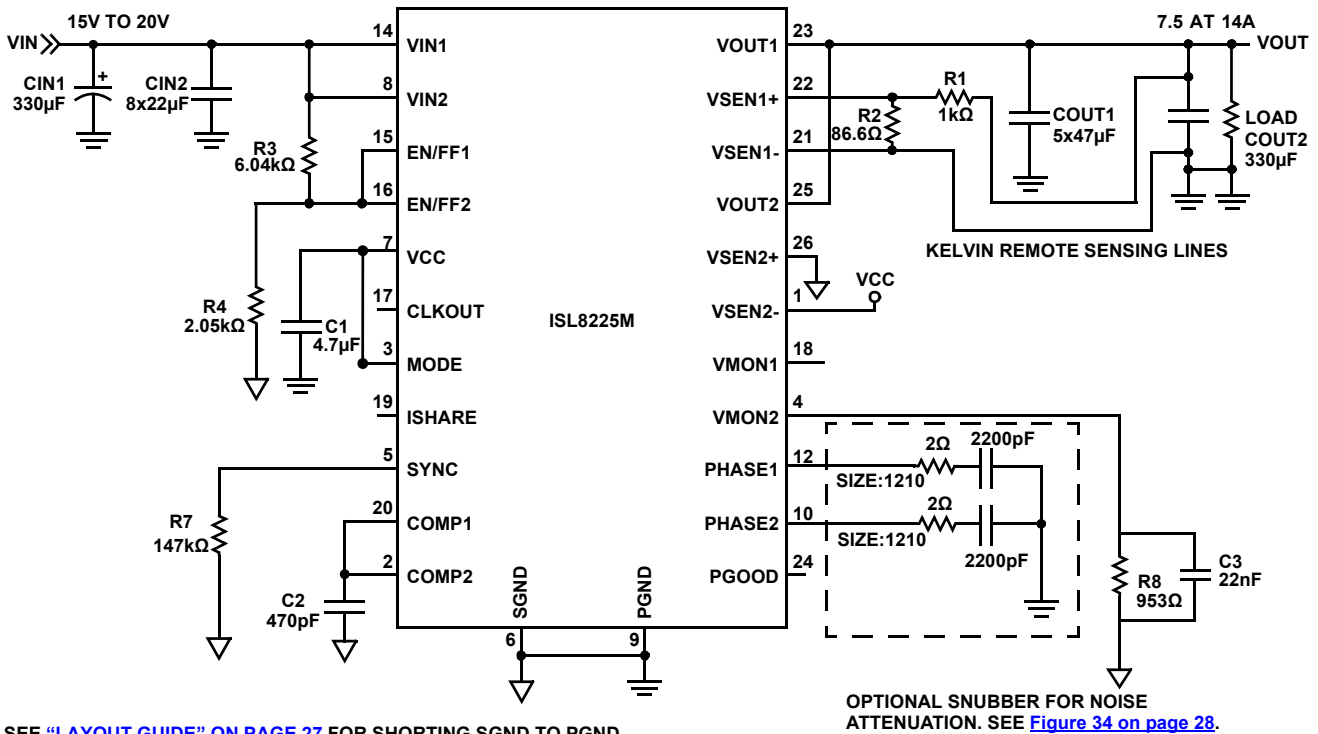

SEE "LAYOUT GUIDE" ON PAGE 27 FOR SHORTING SGND TO PGND

FIGURE 23. PARALLEL USE FOR SINGLE OUTPUT WITH 240° INTERLEAVING

**Typical Application Circuits** (Continued)

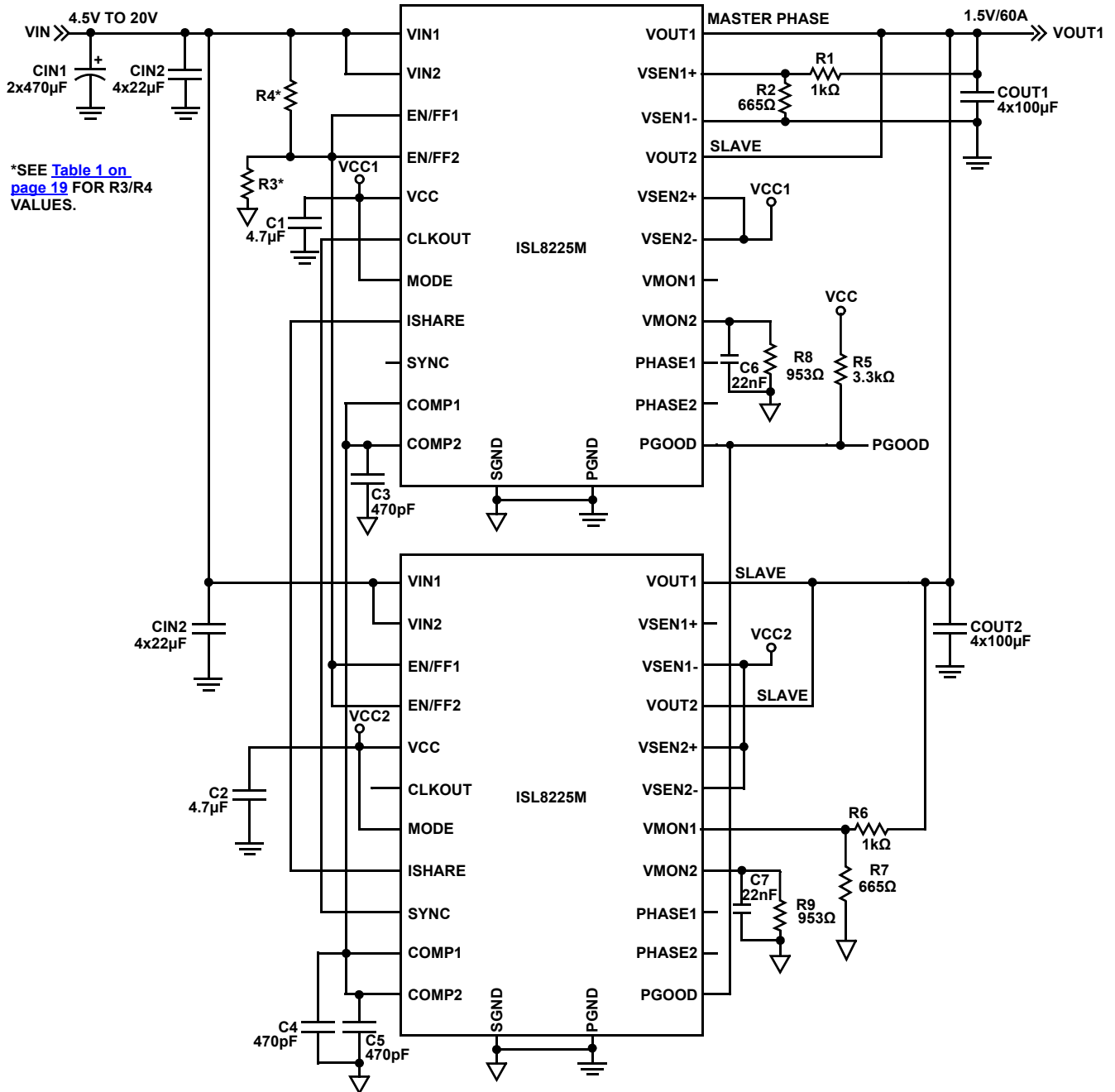

FIGURE 24. 4-PHASE PARALLELED AT 1.5V/60A WITH 90° INTERLEAVING



**Typical Application Circuits** (Continued)

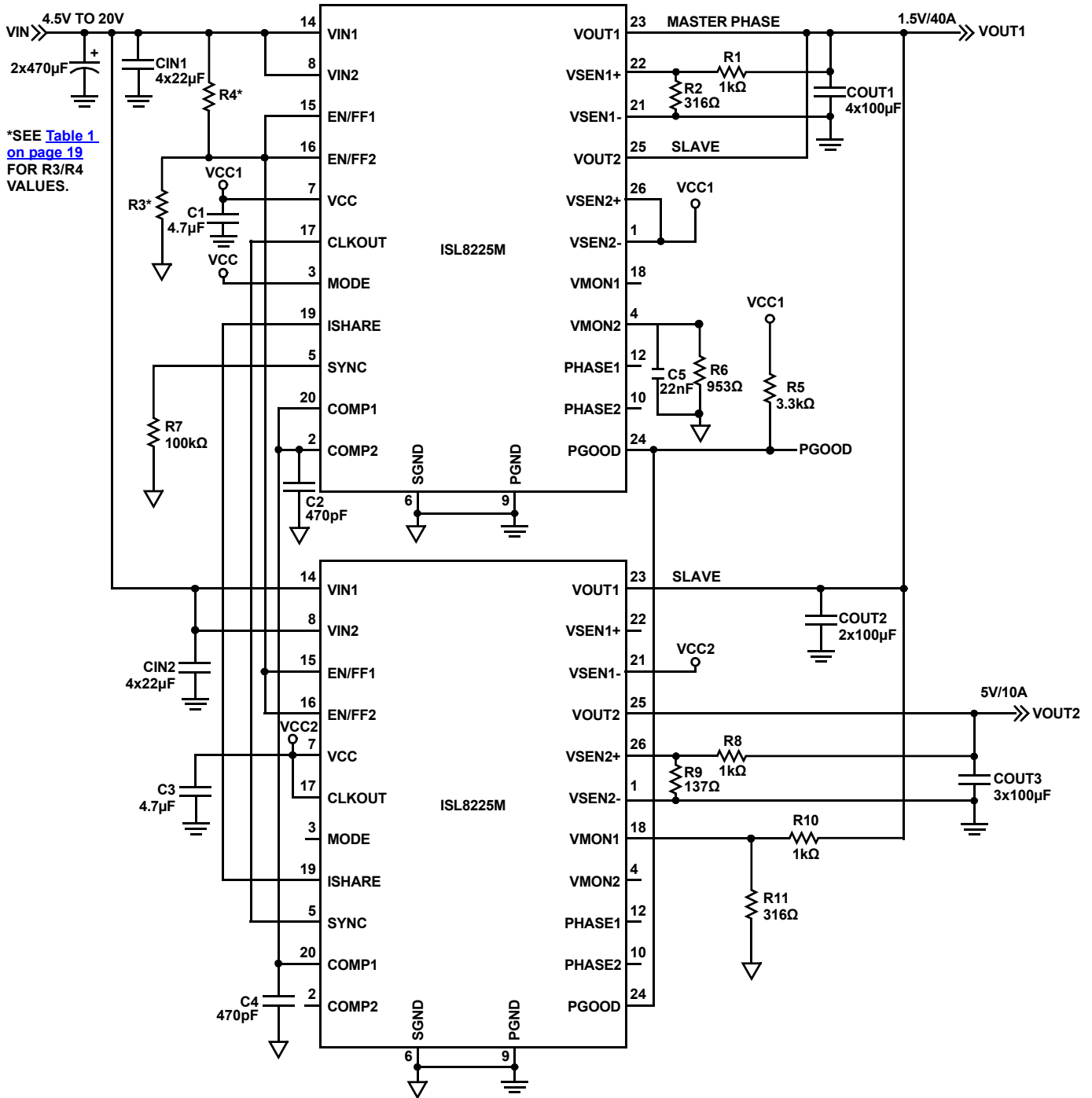

FIGURE 25. 3-PHASE PARALLELED AT 1.5V/40A AND 1-PHASE AT 5V/10A OUTPUT WITH 90° INTERLEAVING

**Typical Application Circuits** (Continued)

\*SEE Table 1 on page 19 FOR R3/R4 VALUES.

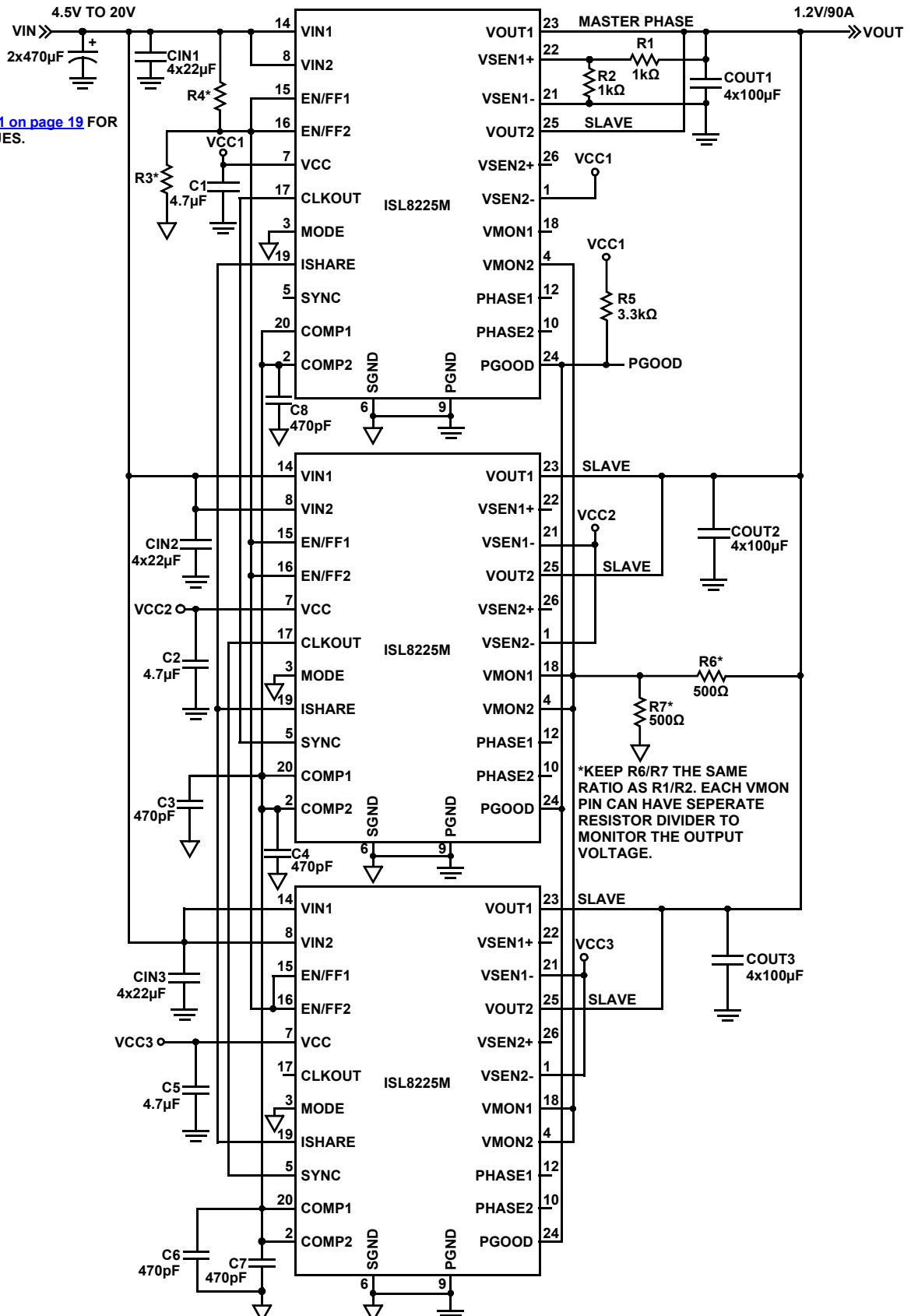

FIGURE 26. SIX-PHASE 90A 1.2V OUTPUT CIRCUIT

TABLE 1. ISL8225M DESIGN GUIDE MATRIX (REFER TO [Figure 18](#))

| CASE | V <sub>IN</sub> (V) | V <sub>OUT</sub> (V) | R2 or R4 (Ω) | CIN1 (BULK) (μF) (Note 10) | CIN2 (CERAMIC) (μF) | COUT1 (CERAMIC) (μF) | COUT2 (BULK) (μF) | CFF (nF) | EN/FF (kΩ) R5/R6 (Note 11) | FREQ. (kHz) | R <sub>SYNC</sub> (kΩ) | LOAD (A) (Note 12) |
|------|---------------------|----------------------|--------------|----------------------------|---------------------|----------------------|-------------------|----------|----------------------------|-------------|------------------------|--------------------|
| 1    | 5                   | 1                    | 1.5k         | 1x330                      | 1x100               | 1x100                | 1x330             | None     | 6.04/3.01                  | 500         | None                   | 15                 |
| 2    | 5                   | 1                    | 1.5k         | 1x330                      | 1x100               | 3x100                | None              | 3.3      | 6.04/3.01                  | 500         | None                   | 15                 |
| 3    | 12                  | 1                    | 1.5k         | 1x330                      | 2x22                | 1x100                | 1x330             | None     | 6.04/1.50                  | 500         | None                   | 15                 |
| 4    | 12                  | 1                    | 1.5k         | 1x330                      | 2x22                | 3x100                | None              | 3.3      | 6.04/1.50                  | 500         | None                   | 15                 |
| 5    | 5                   | 1.2                  | 1.0k         | 1x330                      | 1x100               | 1x100                | 1x330             | None     | 6.04/3.01                  | 500         | None                   | 15                 |
| 6    | 5                   | 1.2                  | 1.0k         | 1x330                      | 1x100               | 3x100                | None              | 3.3      | 6.04/3.01                  | 500         | None                   | 15                 |
| 7    | 12                  | 1.2                  | 1.0k         | 1x330                      | 2x22                | 1x100                | 1x330             | None     | 6.04/1.50                  | 500         | None                   | 15                 |
| 8    | 12                  | 1.2                  | 1.0k         | 1x330                      | 2x22                | 3x100                | None              | 3.3      | 6.04/1.50                  | 500         | None                   | 15                 |
| 9    | 20                  | 1.2                  | 1.0k         | 1x330                      | 2x22                | 1x100                | 1x330             | 3.3      | 6.04/1.50                  | 500         | None                   | 15                 |
| 10   | 20                  | 1.2                  | 1.0k         | 1x330                      | 2x22                | 3x100                | None              | 4.7      | 6.04/1.50                  | 500         | None                   | 15                 |
| 11   | 5                   | 1.5                  | 665          | 1x330                      | 1x100               | 1x100                | 1x330             | None     | 6.04/3.01                  | 500         | None                   | 15                 |
| 12   | 5                   | 1.5                  | 665          | 1x330                      | 1x100               | 3x100                | None              | 3.3      | 6.04/3.01                  | 500         | None                   | 15                 |
| 13   | 12                  | 1.5                  | 665          | 1x330                      | 2x22                | 1x100                | 1x330             | None     | 6.04/1.50                  | 500         | None                   | 15                 |
| 14   | 12                  | 1.5                  | 665          | 1x330                      | 2x22                | 3x100                | None              | 3.3      | 6.04/1.50                  | 500         | None                   | 15                 |
| 15   | 20                  | 1.5                  | 665          | 1x330                      | 2x22                | 1x100                | 1x330             | None     | 6.04/1.50                  | 500         | None                   | 15                 |
| 16   | 20                  | 1.5                  | 665          | 1x330                      | 2x22                | 3x100                | None              | 3.3      | 6.04/1.50                  | 500         | None                   | 15                 |
| 17   | 5                   | 2.5                  | 316          | 1x330                      | 1x100               | 1x100                | 1x330             | None     | 6.04/3.01                  | 500         | None                   | 15                 |
| 18   | 5                   | 2.5                  | 316          | 1x330                      | 1x100               | 3x100                | None              | 3.3      | 6.04/3.01                  | 500         | None                   | 15                 |
| 19   | 12                  | 2.5                  | 316          | 1x330                      | 2x22                | 1x100                | 1x330             | None     | 6.04/1.50                  | 650         | 249                    | 15                 |
| 20   | 12                  | 2.5                  | 316          | 1x330                      | 2x22                | 3x100                | None              | 3.3      | 6.04/1.50                  | 650         | 249                    | 15                 |
| 21   | 20                  | 2.5                  | 316          | 1x330                      | 2x22                | 1x100                | 1x330             | None     | 6.04/1.50                  | 750         | 147                    | 14                 |
| 22   | 20                  | 2.5                  | 316          | 1x330                      | 2x22                | 3x100                | None              | 3.3      | 6.04/1.50                  | 750         | 147                    | 14                 |
| 23   | 5                   | 3.3                  | 221          | 1x330                      | 1x100               | 1x100                | 1x330             | None     | 6.04/3.01                  | 500         | None                   | 15                 |
| 24   | 5                   | 3.3                  | 221          | 1x330                      | 1x100               | 3x100                | None              | None     | 6.04/3.01                  | 500         | None                   | 15                 |
| 25   | 12                  | 3.3                  | 221          | 1x330                      | 2x22                | 1x100                | 1x330             | None     | 6.04/1.50                  | 800         | 124                    | 14                 |
| 26   | 12                  | 3.3                  | 221          | 1x330                      | 2x22                | 3x100                | None              | None     | 6.04/1.50                  | 800         | 124                    | 14                 |
| 27   | 20                  | 3.3                  | 221          | 1x330                      | 2x22                | 1x100                | 1x330             | None     | 6.04/1.50                  | 850         | 107                    | 13                 |
| 28   | 20                  | 3.3                  | 221          | 1x330                      | 2x22                | 3x100                | None              | 3.3      | 6.04/1.50                  | 850         | 107                    | 13                 |
| 29   | 12                  | 5                    | 137          | 1x330                      | 2x22                | 1x100                | 1x330             | None     | 6.04/1.50                  | 950         | 82.5                   | 12                 |
| 30   | 12                  | 5                    | 137          | 1x330                      | 2x22                | 3x100                | None              | None     | 6.04/1.50                  | 950         | 82.5                   | 12                 |
| 31   | 20                  | 5                    | 137          | 1x330                      | 2x22                | 1x100                | 1x330             | None     | 6.04/1.50                  | 950         | 82.5                   | 10                 |
| 32   | 20                  | 5                    | 137          | 1x330                      | 2x22                | 3x100                | None              | 3.3      | 6.04/1.50                  | 950         | 82.5                   | 10                 |
| 33   | 12                  | 6.5                  | 102          | 1x330                      | 4x22                | 2x47                 | 1x330             | None     | 16.5/4.12                  | 750         | 147                    | 10                 |
| 34   | 12                  | 6.5                  | 102          | 1x330                      | 4x22                | 6x47                 | None              | 3.3      | 16.5/4.12                  | 750         | 147                    | 10                 |
| 35   | 20                  | 6.5                  | 102          | 1x330                      | 4x22                | 2x47                 | 1x330             | None     | 16.5/4.12                  | 750         | 147                    | 10                 |
| 36   | 20                  | 6.5                  | 102          | 1x330                      | 4x22                | 6x47                 | None              | 3.3      | 16.5/4.12                  | 750         | 147                    | 10                 |
| 37   | 12                  | 7.5                  | 86.6         | 1x330                      | 4x22                | 2x47                 | 1x330             | None     | 16.5/4.12                  | 750         | 147                    | 7                  |

TABLE 1. ISL8225M DESIGN GUIDE MATRIX (REFER TO [Figure 18](#)) (Continued)

| CASE | V <sub>IN</sub><br>(V) | V <sub>OUT</sub><br>(V) | R2 or R4<br>(Ω) | CIN1<br>(BULK)<br>μF<br>( <a href="#">Note 10</a> ) | CIN2<br>(CERAMIC)<br>(μF) | COU1<br>(CERAMIC)<br>(μF) | COU2<br>(BULK)<br>(μF) | CFF<br>(nF) | EN/FF (kΩ)<br>R5/R6<br>( <a href="#">Note 11</a> ) | FREQ.<br>(kHz) | R <sub>SYNC</sub><br>(kΩ) | LOAD<br>(A)<br>( <a href="#">Note 12</a> ) |
|------|------------------------|-------------------------|-----------------|---|---------------------------|---------------------------|------------------------|-------------|--|----------------|---------------------------|--|
| 38   | 12                     | 7.5                     | 86.6            | 1x330   | 4x22                      | 6x47                      | None                   | 3.3         | 16.5/4.12  | 750            | 147                       | 7  |
| 39   | 20                     | 7.5                     | 86.6            | 1x330   | 4x22                      | 2x47                      | 1x330                  | None        | 16.5/4.12  | 750            | 147                       | 7  |
| 40   | 20                     | 7.5                     | 86.6            | 1x330   | 4x22                      | 6x47                      | None                   | 3.3         | 16.5/4.12  | 750            | 147                       | 7  |

## NOTES:

10. CIN bulk capacitor is optional only for decoupling noise due to the long input cable. CIN2 and COU1 ceramic capacitors are listed for one phase only. Please double the capacitor quantity for dual-phase operations.
11. EN/FF resistor divider is tied directly to VIN. The resistors listed here are for two channels' EN/FF pins tied together. If the separate resistor divider is used for each channel, the resistor value needs to be doubled.
12. MAX load current listed in the table is for conditions at +25°C and no air flow on a typical Intersil 4-layer evaluation board.

TABLE 2. RECOMMENDED I/O CAPACITOR IN [Table 1](#)

| VENDOR                           | VALUE             | PART NUMBER        |
|----------------------------------|-------------------|--------------------|
| TDK, Input and Output Ceramic    | 100μF, 6.3V, 1210 | C3225X5R0J107M     |
| Murata, Input and Output Ceramic | 100μF, 6.3V, 1210 | GRM32ER60J107M     |
| AVX, Input and Output Ceramic    | 100μF, 6.3V, 1210 | 12106D107MAT2A     |
| Murata, Input Ceramic            | 22μF, 25V, 1210   | GRM32ER61E226KE15L |
| Taiyo Yuden, Input Ceramic       | 22μF, 25V, 1210   | TMK325BJ226MM-T    |
| AVX, Input Ceramic               | 22μF, 25V, 1210   | 12103D226KAT2A     |
| Panasonic POSCAP, Output Bulk    | 330μF, 10V        | 10TPB330M          |
| Panasonic SMT, Input Bulk        | 330μF, 25V        | EEVHA1E331UP       |
| Murata, Input and Output Ceramic | 47μF, 10V, 1210   | GRM32ER71A476KE15L |

TABLE 3. ISL8225M OPERATION MODES

| 1ST MODULE (I = INPUT; O = OUTPUT; I/O = INPUT AND OUTPUT, BI-DIRECTION) |  |             |                        |                 |                 |   |                  |   |   | MODES OF OPERATION                       |  | OUTPUT (SEE DESCRIPTION FOR DETAILS)          |
|--|--|-------------|------------------------|-----------------|-----------------|---|------------------|---|---|--|--|---|
| MODE   | EN1/FF1 (I)  | EN2/FF2 (I) | VSEN2- (I)             | MODE (I)        | VSEN2+ (I)      | CLKOUT/REFIN WRT 1 <sup>ST</sup> (I OR O) | VMON2 (Note 14)  | VMON1 OF 2 <sup>ND</sup> MODULE (Note 14) | 2 <sup>ND</sup> CHANNEL WRT 1 <sup>ST</sup> (O) (Note 13) | OPERATION MODE OF 2 <sup>ND</sup> MODULE | OPERATION MODE OF 3 <sup>RD</sup> MODULE |   |
| 1  | 0  | 0           | -                      | -               | -               | -   | -                | -   | -   | -  | -  | Disabled                                      |
| 2A   | 0  | 1           | Active                 | Active          | Active          | -   | Active           | -   | VMON1 = VMON2 to Keep PGOOD Valid                         | -  | -  | Single Phase                                  |
| 2B   | 1  | 0           | -                      | -               | -               | -   | -                | -   | VMON1 = VMON2 to Keep PGOOD Valid                         | -  | -  | Single Phase                                  |
| 3A   | 1  | 1           | <V <sub>CC</sub> -0.7V | Active          | Active          | 29% to 45% of V <sub>CC</sub> (I)         | Active           | -   | 0°  | -  | -  | Dual Regulator                                |
| 3B   | 1  | 1           | <V <sub>CC</sub> -0.7V | Active          | Active          | 45% to 62% of V <sub>CC</sub> (I)         | Active           | -   | 90°   | -  | -  | Dual Regulator                                |
| 3C   | 1  | 1           | <V <sub>CC</sub> -0.7V | Active          | Active          | >62% of V <sub>CC</sub> (I)               | Active           | -   | 180°  | -  | -  | Dual Regulator                                |
| 4  | 1  | 1           | <V <sub>CC</sub> -0.7V | Active          | Active          | <29% of V <sub>CC</sub> (I)               | Active           | -   | -60°  | -  | -  | DDR Mode                                      |
| 5A   | 1  | 1           | V <sub>CC</sub>        | GND             | -               | 60°                                       | VMON1 or Divider | -   | 180°  | -  | -  | 2-Phase                                       |
| 5B   | 1  | 1           | V <sub>CC</sub>        | GND             | -               | 60°                                       | Divider          | Divider                                   | 180°  | 5B                                       | 5B                                       | 6-Phase                                       |
| 5C   | 1  | 1           | V <sub>CC</sub>        | GND             | -               | 60°                                       | VMON1 or Divider | Active                                    | 180°  | 5C                                       | 5C                                       | 3 Outputs                                     |
| 6  | 1  | 1           | V <sub>CC</sub>        | V <sub>CC</sub> | GND             | 120°                                      | 953Ω//22nF       | Active                                    | 240°  | 2B                                       | -  | 3-Phase                                       |
| 7A   | 1  | 1           | V <sub>CC</sub>        | V <sub>CC</sub> | V <sub>CC</sub> | 90°                                       | 953Ω//22nF       | Divider                                   | 180°  | 7A                                       | -  | 4-Phase                                       |
| 7B   | 1  | 1           | V <sub>CC</sub>        | V <sub>CC</sub> | V <sub>CC</sub> | 90°                                       | 953Ω//22nF       | Active                                    | 180°  | 7B                                       | -  | 2 Outputs (1 <sup>st</sup> module in Mode 7A) |
| 7C   | 1  | 1           | V <sub>CC</sub>        | V <sub>CC</sub> | V <sub>CC</sub> | 90°                                       | 953Ω//22nF       | Active                                    | 180°  | 3, 4                                     | -  | 3 Outputs (1 <sup>st</sup> module in Mode 7A) |
| 8  | Cascaded Module Operation MODEs 5B+5B+7A+5B+5B+5B/7A, No External Clock Required |             |                        |                 |                 |   |                  |   |   |  |  | 12-Phase                                      |
| 9  | External Clock or External Logic Circuits Required for Equal Phase Interval      |             |                        |                 |                 |   |                  |   |   |  |  | 5, 7, 8, 9, 10, 11, or (PHASE >12)            |

## NOTE:

13. "2<sup>ND</sup> CHANNEL WRT 1<sup>ST</sup>" means "second channel with respect to first;" in other words, Channel 2 lags Channel 1 by the degrees specified in this column. For example, 90° means Channel 2 lags Channel 1 by 90°; -60° means Channel 2 leads Channel 1 by 60°.
14. "VMON1" means that the pin is tied to the VMON1 pin of the same module.  
 "Divider" means that there is a resistor divider from VOUT to SGND; refer to [Figure 26](#).  
 "953Ω//22nF" means that there are 953Ω resistor and 22nF connecting the pin to SGND; refer to [Figure 24](#).

## Application Information

### Programming the Output Voltage

The ISL8225M has an internal  $0.6V \pm 0.7\%$  reference voltage. Programming the output voltage requires a resistor divider (R1 and R2) between the VOUT, VSEN+, and VSEN- pins, as shown in [Figure 18](#). Please note that the output voltage accuracy is also dependent on the resistor accuracy of R1 and R2. The user needs to select a high accuracy resistor (i.e. 0.5%) in order to achieve the overall output accuracy. The output voltage can be calculated as shown in [Equation 1](#):

$$V_{OUT} = 0.6 \times \left(1 + \frac{R1}{R2}\right) \quad (\text{EQ. 1})$$

NOTE: It is recommended to use a  $1k\Omega$  value for the top resistor, R1. The value of the bottom resistor for different output voltages is shown in [Table 4](#).

TABLE 4. VALUE OF BOTTOM RESISTOR FOR DIFFERENT OUTPUT VOLTAGES (V<sub>OUT</sub> vs R2)

| R1 (Ω) | V <sub>OUT</sub> (V) | R2 (Ω) |
|--------|----------------------|--------|
| 1k     | 0.6                  | Open   |
| 1k     | 0.8                  | 3.01k  |
| 1k     | 1.0                  | 1.50k  |
| 1k     | 1.2                  | 1.00k  |
| 1k     | 1.5                  | 665    |
| 1k     | 1.8                  | 491    |
| 1k     | 2.0                  | 422    |
| 1k     | 2.5                  | 316    |
| 1k     | 3.3                  | 221    |
| 1k     | 5.0                  | 137    |
| 1k     | 6.0                  | 110    |
| 1k     | 6.5                  | 102    |
| 1k     | 7.5                  | 86.6   |

Due to the minimum off-time limit of 410ns, the module has a maximum output voltage, depending on input voltage. Refer to [Figure 27](#) for the 5V input voltage limitation.

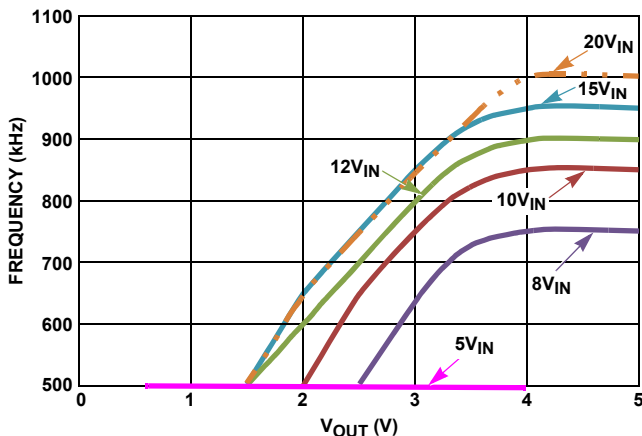

FIGURE 27. RECOMMENDED FREQUENCY vs V<sub>IN</sub> AT V<sub>OUT</sub>

At higher output voltage, the inductor ripple increases, which makes both output ripple and inductor power loss higher. Therefore, higher switching frequency can be used to reduce the inductor ripple. However, higher switching frequency results in higher switching loss and higher gate driving loss, so the overall efficiency may suffer. Because of thermal and efficiency concerns, the optimal switching frequency is 750kHz for 6.5V and 7.5V output. With 750kHz switching frequency, the minimum input voltage is 10V for 6.5V output and 11V for 7.5V. Please refer to [Figure 27](#) for frequency selection at different operating conditions, then refer to [Figure 31](#) to choose R<sub>SYNC</sub>.

### Selection of Input Capacitor

Selection of the input filter capacitor is based on how much ripple the supply can tolerate on the DC input line. The larger the capacitor, the less ripple expected, however, consideration should be given to the higher surge current during power-up. The ISL8225M provides a soft-start function that controls and limits the current surge. The value of the input capacitor can be calculated as shown in [Equation 2](#):

$$C_{IN(MIN)} = \frac{I_O \cdot D(1-D)}{V_{P-P} \cdot f_{SW}} \quad (\text{EQ. 2})$$

where:

- C<sub>IN(MIN)</sub> is the minimum required input capacitance (μF)
- I<sub>O</sub> is the output current (A)
- D is the duty cycle
- V<sub>P-P</sub> is the allowable peak-to-peak voltage (V)
- f<sub>SW</sub> is the switching frequency (Hz)

In addition to the bulk capacitance, some low Equivalent Series Resistance (ESR) ceramic capacitance is recommended to decouple between the VIN and PGND of each channel. [Table 2](#) shows for some recommended capacitors. This capacitance reduces voltage ringing created by the switching current across parasitic circuit elements. All these ceramic capacitors should be placed as closely as possible to the module pins. The estimated RMS current should be considered in choosing ceramic capacitors.

$$I_{IN(RMS)} = \frac{I_{O,AVG} \sqrt{D(1-D)}}{\eta} \quad (\text{EQ. 3})$$

Each 10μF X5R or X7R ceramic capacitor is typically good for 2A to 3A of RMS ripple current. Refer to the capacitor vendor to check the RMS current ratings. In a typical 15A output application for one channel, if the duty cycle is 0.5, it needs at least three 10μF X5R or X7R ceramic input capacitors.

## Selection of Output Capacitors

The ISL8225M is designed for low output voltage ripple. The output voltage ripple and transient requirements can be met with bulk output capacitors ( $C_{OUT}$ ) that have adequately low ESR.  $C_{OUT}$  can be a low ESR tantalum capacitor, a low ESR polymer capacitor, or a ceramic capacitor. The typical capacitance is 330 $\mu$ F, and decoupled ceramic output capacitors are used for each phase. See [Tables 1](#) and [2](#) for more capacitor information. Internally optimized loop compensation provides sufficient stability margins for all ceramic capacitor applications, with a recommended total value of 300 $\mu$ F per phase. Additional output filtering may be needed if further reduction of output ripple or dynamic transient spike is required.

## EN/FF Turn ON/OFF

Each output of the ISL8225M can be turned on/off independently through the EN/FF pins. For parallel use, tie all EN/FF pins together. Since this pin has the feed-forward function, the voltage on this pin can actively adjust the loop gain to be constant for variable input voltage. Please refer to [Table 1](#) to select the resistor divider for commonly used conditions. Otherwise, use the following procedures to finish the EN/FF design:

1. A resistor divider from  $V_{IN}$  to GND is recommended to set the EN/FF voltage between 1.25V to 5.0V. The resistor divider ratio is recommended to be between 3/1 to 4/1 (as shown in [Figure 21](#)) with a resistor divider at 7.15k $\Omega$ /2.05k $\Omega$ .
2. Check EN turn-on hysteresis (Recommend  $V_{EN\_HYS} > 0.3V$ ):

$$V_{EN\_HYS} = N \cdot R_{UP} \cdot 3 \times 10^{-5} \quad (\text{EQ. 4})$$

where:

- $R_{UP}$  is the top resistor of the resistor divider
  - $N$  is the total number of the EN/FF pins tied to the resistor divider
3. Set the maximum current flowing through the top pull-up resistor  $R_{UP}$  to below 7mA (considering EN/FF is pulled to ground ( $V_{EN/FF} = 0$ )). Refer to [Figure 25](#); a 3.01k $\Omega$ /1k $\Omega$  resistor is used to allow for the input voltage from 5V to 20V operation. In addition, the maximum current flowing through  $R_5$  is 6.6mA (<7mA).
  4. If the EN/FF is controlled by system EN signal instead of the input voltage, we recommend setting the fixed EN/FF voltage to about 1/3.5 of the input voltage. If the input voltage is 12V, a 3.3V system EN signal can be tied to EN/FF pin directly.
  5. If the input voltage is below 5.5V, it is recommended to have EN/FF voltage >1.5V to have better stability. The input voltage can be directly tied to the VCC pin to disable the internal LDO.
  6. A 1nF capacitor is recommended on the EN/FF pin to avoid the noise injecting into the feed-forward loop.

## Thermal Considerations

The ISL8225M QFN package offers typical junction to ambient thermal resistance  $\theta_{JA}$  of approximately 10 $^{\circ}$ C/W at natural convection (~5.8 $^{\circ}$ C/W at 400LFM) with a typical 4-layer PCB. Therefore, use [Equation 5](#) to estimate the module junction temperature:

$$T_{\text{junction}} = P \times \theta_{JA} + T_{\text{ambient}} \quad (\text{EQ. 5})$$

where:

- $T_{\text{junction}}$  is the module internal maximum temperature ( $^{\circ}$ C)
- $T_{\text{ambient}}$  is the system ambient temperature ( $^{\circ}$ C)
- $P$  is the total power loss of the module package (W)
- $\theta_{JA}$  is the thermal resistance of module junction to ambient

If the calculated temperature,  $T_{\text{junction}}$ , is over the required design target, the extra cooling scheme is required. Please refer to [“Current Derating” on page 28](#) for adding air flow.

## Functional Description

### Initialization

Initially, the Power-On Reset (POR) circuits continuously monitor bias voltages ( $V_{CC}$ ) and voltage at the EN/FF pin. The POR function initiates soft-start operation 384 clock cycles after: (1) the EN pin voltage is pulled above 0.8V, (2) all input supplies exceed their POR thresholds, and (3) the PLL locking time expires. The Enable pin can be used as a voltage monitor and to set the desired hysteresis, with an internal 30 $\mu$ A sinking current going through an external resistor divider. The sinking current is disengaged after the system is enabled. This feature is specially designed for applications that require higher input rail POR for better undervoltage protection. For example, in 12V applications,  $R_{UP} = 53.6k\Omega$  and  $R_{DOWN} = 5.23k\Omega$  sets the turn-on threshold ( $V_{EN\_RTH}$ ) to 10.6V and the turn-off threshold ( $V_{EN\_FTH}$ ) to 9V, with 1.6V hysteresis ( $V_{EN\_HYS}$ ).

During shutdown or fault conditions, soft-start is quickly reset, and the gate driver immediately changes state (<100ns) when input drops below POR.

### Enable and Voltage Feed-forward

Voltage applied to the EN/FF pin is fed to adjust the sawtooth amplitude of the channel. Sawtooth amplitude is set to 1.25 times the corresponding FF voltage when the module is enabled. This configuration helps maintain a constant gain. This configuration also helps maintain input voltage to achieve optimum loop response over a wide input voltage range.

A 384-cycle delay is added after the system reaches its rising POR and prior to soft-start. The RC timing at the FF pin should be small enough to ensure that the input bus reaches its static state and that the internal ramp circuitry stabilizes before soft-start. A large RC could cause the internal ramp amplitude not to synchronize with the input bus voltage during output start-up or when recovering from faults. A 1nF capacitor is recommended as a starting value for typical applications.

In a multi-module system, with the EN pins are wired together, all modules can immediately turn off, at one time, when a fault condition occurs in one or more modules. A fault pulls the EN pin low, disabling all modules, and does not create current bounce; thus, no single channel is overstressed when a fault occurs.

Because the EN pins are pulled down under fault conditions, the pull-up resistor ( $R_{UP}$ ) should be scaled to sink no more than 7mA current from the EN pin. Essentially, the EN pins cannot be directly connected to VCC.

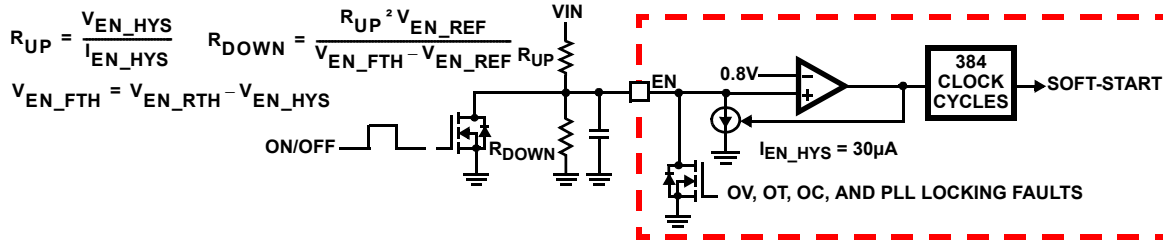

FIGURE 28. SIMPLIFIED ENABLE AND VOLTAGE FEED-FORWARD CIRCUIT

### Soft-Start

The ISL8225M has an internal, digital, precharged soft-start circuitry (Figures 29 to 31). The circuitry has a rise time inversely proportional to the switching frequency. Rise time is determined by a digital counter that increments with every pulse of the phase clock. The full soft-start time from 0V to 0.6V can be estimated as shown in Equation 6. The typical soft-start time is ~2.5ms.

$$t_{SS} = \frac{1280}{f_{SW}} \quad (EQ. 6)$$

The ISL8225M is able to work under a precharged output. The PWM outputs do not feed to the drivers until the first PWM pulse is seen. The low-side MOSFET is on for the first clock cycle, to provide charge for the bootstrap capacitor. If the precharged output voltage is greater than the final target level but less than the 113% set point, switching does not start until the output voltage is reduced to the target voltage and the first PWM pulse is generated. The maximum allowable precharged level is 113%. If the precharged level is above 113% but below 120%, the output hiccups between 113% (LGATE turns on) and 87% (LGATE turns off), while EN is pulled low. If the precharged load voltage is above 120% of the targeted output voltage, then the controller is latched off and cannot power up.

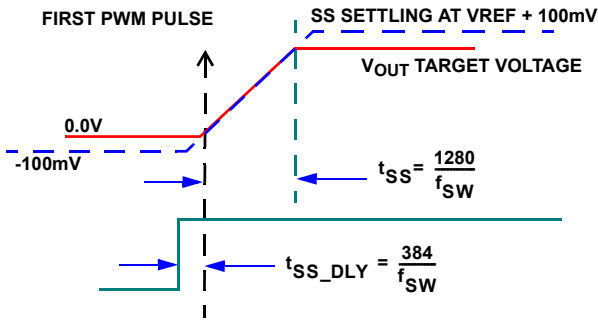

FIGURE 29. SOFT-START WITH  $V_{OUT} = 0V$

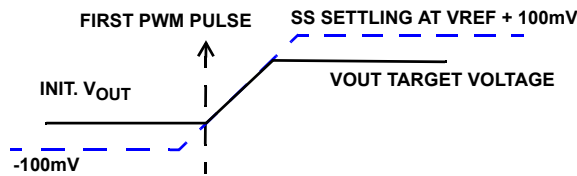

FIGURE 30. SOFT-START WITH  $V_{OUT} < TARGET VOLTAGE$

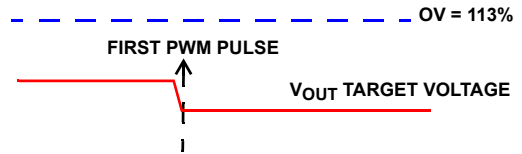

FIGURE 31. SOFT-START WITH  $V_{OUT}$  BELOW 113% BUT ABOVE FINAL TARGET VOLTAGE

### Power-Good

Power-good comparators monitor voltage on the VMON pin. Trip points are shown in Figure 32. PGOOD is not asserted until the soft-start cycle is complete. PGOOD pulls low upon both ENs disabling it or when the VMON voltage is out of the threshold window. PGOOD does not pull low until the fault presents for three consecutive clock cycles.

UV indication is not enabled until the end of soft-start. In a UV event, if the output drops below -13% of the target level due to a reason other than OV, OC, OT, or PLL faults (cases when EN is not pulled low), PGOOD is pulled low.

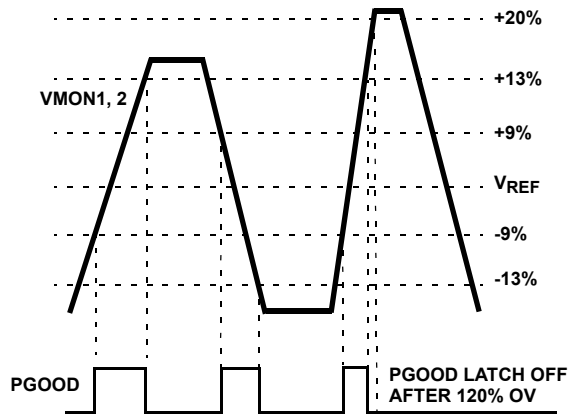
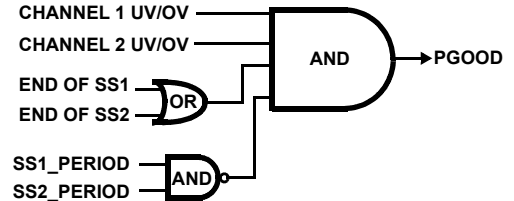

FIGURE 32. POWER-GOOD THRESHOLD WINDOW



## Current Share

In parallel operations, the share bus voltages ( $I_{SHARE}$ ) of different modules must tie together. The  $I_{SHARE}$  pin voltage is set by an internal resistor and represents the average current of all active modules. The average current signal is compared with the local module current, and the current share error signal is fed into the current correction block to adjust each module's PWM pulse accordingly. The current share function provides at least 10% overall accuracy between modules. The current share bus works for up to 12 phases without requiring an external clock. A 470pF ~1nF capacitor is recommended for each  $I_{SHARE}$  pin.

In current sharing scheme, all slave channels have the feedback loops disabled with the  $V_{SEN-}$  pin tied to VCC. The master channel can control all modules with  $COMP$  and  $I_{SHARE}$  pins tied together. For phase-shift setting, all  $V_{MON}$  pins of slave channels are needed to set 0.6V for monitoring use only. Typically, the slaved  $V_{MON}$  pins can be tied together with a resistor divider to  $V_{OUT}$ . However, if the  $MODE$  pin is tied to VCC for mode setting, the related  $V_{MON2}$  pin is needed to tie to  $SGND$  with a 953 $\Omega$  resistor and 22nF capacitor, as shown in [Figure 25](#) on [page 17](#). If there are multiple modules paralleled with the  $MODE$  pins tied to VCC, each  $V_{MON2}$  pin of the slave module needs to have a 953 $\Omega$  resistor to  $GND$  while all  $V_{MON1}$  pins of the slave modules can be tied together with a resistor divider from  $V_{OUT}$  to  $GND$ , as shown in [Figure 26](#) on [page 18](#). Also see [Table 3](#) for  $V_{MON}$  settings.

Because of the typical 5.4V VCC and 7.5k $\Omega$  resistor between  $MODE$  pin and  $V_{MON2}$  pin, the 953 $\Omega$  resistor maintains  $V_{MON2}$  pin voltage close to 0.6V, so output OVP/UVP (caused by  $V_{MON2}$  voltage too high or too low) will not be triggered falsely by part to part tolerance at mass production. The 22nF capacitor is used to avoid output UVP/OVP triggered during input start-up.

## Overvoltage Protection (OVP)

The overvoltage (OV) protection indication circuitry monitors voltage on the  $V_{MON}$  pin. OV protection is active from the beginning of soft-start. An OV condition (>120%) would latch the IC off. In this condition, the high-side MOSFET (Q1 or Q3) latches off permanently. The low-side MOSFET (Q2 or Q4) turns on immediately at the time of OV trip and then turns off permanently after the output voltage drops below 87%.  $EN$  and  $PGOOD$  are also latched low in an OV event. The latch condition can be reset only by recycling  $V_{CC}$ .

There is another non-latch OV protection (113% of target level). When  $EN$  is low and output is over 113% OV, the low-side MOSFET turns on until output drops below 87%. This action protects the power trains when even a single channel of a multi-module system detects OV. The low-side MOSFET always turns on when  $EN = LOW$  and the output voltage rises above 113% (all  $EN$  pins are tied together) and turns off after the output drops below 87%. Thus, in a high phase count application (multi-module mode), all cascaded modules can latch off simultaneously via the  $EN$  pins ( $EN$  pins are tied together in multi-phase mode). Each channel shares the same sink current to reduce stress and eliminate bouncing among phases.

## Over-Temperature Protection (OTP)

When the junction temperature of the internal controller is greater than +150 °C (typically), the  $EN$  pin is pulled low to inform

other cascaded channels via their  $EN$  pins. All connected  $EN$ s stay low and then release after the module's junction temperature drops below +125 °C (typically), a +25 °C hysteresis (typically).

## Overcurrent Protection (OCP)

The OCP peak level is set to about 20A for each channel, but the OC trip point can vary, due mainly to MOSFET  $r_{DS(ON)}$  variations (over process, current, and temperature). The OCP can be increased by increasing the switching frequency since the inductor ripple is reduced. However, the module efficiency drops accordingly with more switching loss. When OCP is triggered, the controller pulls  $EN$  low immediately to turn off all switches. The OCP function is enabled at start-up and has a 7-cycle delay before it triggers.

In multi-module operation,  $I_{SHARE}$  pins can be connected to create  $V_{I_{SHARE}}$ , which represents the average current of all active channels. Total system currents are compared with a precision threshold to determine the overcurrent condition. Each channel also has an additional overcurrent set point with a 7-cycle delay. This scheme helps protect modules from damage in multi-module mode by having each module carry less current than the set point.

For overload and hard short conditions, overcurrent protection reduces the regulator RMS output current to much less than full load by putting the controller into hiccup mode. A delay equal to three soft-start intervals is entered to allow time to clear the disturbance. After the delay time, the controller initiates a soft-start interval. If the output voltage comes up and returns to regulation,  $PGOOD$  transitions high. If the OC trip is exceeded during the soft-start interval, the controller pulls  $EN$  low again. The  $PGOOD$  signal remains low, and the soft-start interval is allowed to expire. Another soft-start interval is initiated after the delay interval. If an overcurrent trip occurs again, this same cycle repeats until the fault is removed. Since the output voltage may trigger the OVP if the output current changes too fast, the module can go into latch-off mode. In this case, the module needs to be restarted.

## Frequency Synchronization and Phase Lock Loop

The  $SYNC$  pin has two primary capabilities: fixed frequency operation and synchronized frequency operation. The ISL8225M has an internally set fixed frequency of 500kHz. By tying a resistor ( $R_{SYNC}$ ) to  $SGND$  from the  $SYNC$  pin, the switching frequency can be set to be more than 500kHz. To increase the switching frequency, select an externally connected resistor,  $R_{SYNC}$ , from  $SYNC$  to  $SGND$  according to the frequency setting curve shown in [Figure 33](#). See [Table 1](#) for  $R_{SYNC}$  at commonly used frequency.

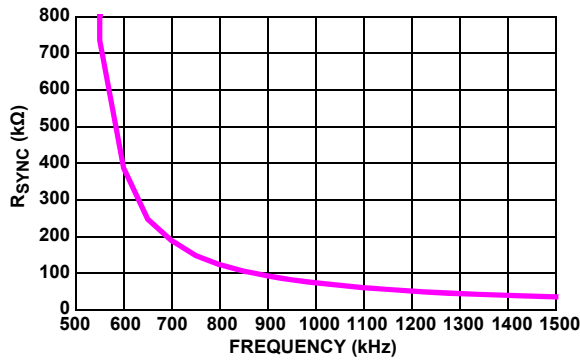
FIGURE 33.  $R_{SYNC}$  vs SWITCHING FREQUENCY

Connecting the SYNC pin to an external square-pulse waveform (such as the CLKOUT signal, typically 50% duty cycle from another ISL8225M) synchronizes the ISL8225M switching frequency to the fundamental frequency of the input waveform. The synchronized frequency can be from 300kHz to 1500kHz. The applied square-pulse recommended high level voltage range is  $3V$  to  $V_{CC}+0.3V$ . The frequency synchronization feature synchronizes the leading edge of the CLKOUT signal with the falling edge of Channel 1's PWM signal. CLKOUT is not available until PLL locks. No capacitor is recommended on the SYNC pin.

Locking time is typically  $130\mu s$ . EN is not released for a soft-start cycle until SYNC is stabilized and PLL is locking. Connecting all EN pins together in a multi-phase configuration is recommended.

Loss of a synchronization signal for 13 clock cycles causes the module to be disabled until PLL returns locking, at which point, a soft-start cycle is initiated and normal operation resumes. Holding SYNC low disables the module.

NOTE: That the quick change of the synchronization signal can cause module shutdown.

## Tracking Function

If CLKOUT is less than 800mV, an external soft-start ramp (0.6V) can be in parallel with the Channel 2 internal soft-start ramp for tracking applications. Therefore, the Channel 2's output voltage can track the output voltage of Channel 1.

The tracking function can be applied to a typical Double Data Rate (DDR) memory application, as shown in [Figure 20](#) on [page 14](#). The output voltage (typical VTT output) of Channel 2 tracks with the input voltage [typical  $VDDQ/(1+k)$  from Channel 1] at the CLKOUT pin. As for the external input signal and the internal reference signal (ramp and 0.6V), the one with the lowest voltage is used as the reference for comparing with the FB signal. In DDR configuration, VTT channel should start up later, after its internal soft-start ramp, such that VTT tracks the voltage on the CLKOUT pin derived from VDDQ. This configuration can be achieved by adding more filtering at EN/FF1 than at EN/FF2.

It is suggested to scale the target CLKOUT voltage to 0.612V (2% above 0.6V reference) with an external resistor divider. After start-up, the internal reference takes over to maintain the good regulation of VTT. The resistor divider ratio (k) of R7/R8 in [Figure 20](#) is Based on the feedback divider of VDDQ

(R1 and R2) together with the 0.612V target CLKOUT voltage as shown in [Equation 7](#):

$$k = \left(1 + \frac{R1}{R2}\right) \div 1.02 - 1 \quad (\text{EQ. 7})$$

For [Figure 20](#),  $R1 = 1k\Omega$ ,  $R2 = 316\Omega$ . The resistor divider ratio of R7/R8 is calculated as 3.083, so R8 is  $324\Omega$  with  $1k\Omega$  used as R7.

## Mode Programming

ISL8225M can be programmed for dual-output, paralleled single-output or mixed outputs (Channel 1 in parallel and Channel 2 in dual-output). With multiple ISL8225Ms, up to 6 modules using its internal cascaded clock signal control, the modules can supply large current up to 180A. For complete operation, please refer to [Table 3](#) on [page 21](#). Commonly used settings are listed in [Table 5](#).

TABLE 5. PHASE-SHIFT SETTING

| OPERATION                                 | PHASE-SHIFT BETWEEN PHASES | VSEN2- | VSEN2+ | CLKOUT | MODE |
|---|----------------------------|--------|--------|--------|------|
| Dual Output ( <a href="#">Figure 18</a> ) | 180°                       | N/C    | N/C    | VCC    | N/C  |
| 30A ( <a href="#">Figure 19</a> )         | 180°                       | VCC    | N/C    | N/C    | SGND |
| 30A ( <a href="#">Figure 23</a> )         | 240°                       | VCC    | SGND   | N/C    | VCC  |
| 60A ( <a href="#">Figure 24</a> )         | 90°                        | VCC    | VCC    | N/C    | VCC  |
| 90A ( <a href="#">Figure 26</a> )         | 60°                        | VCC    | N/C    | N/C    | SGND |

When the module is in the dual-output condition, depending upon the voltage level at CLKOUT (which is set by the  $V_{CC}$  resistor divider output), ISL8225M operates with phase shifted as the CLKOUT voltage shown in [Table 6](#). The phase shift is latched as  $V_{CC}$  rises above POR; it cannot be changed on the fly.

TABLE 6. CLKOUT TO PROGRAM PHASE SHIFT AT DUAL-OUTPUT

| CLKOUT VOLTAGE SETTING | PHASE FOR CHANNEL 2 WRT CHANNEL 1 | RECOMMENDED CLKOUT VOLTAGE |
|------------------------|-----------------------------------|----------------------------|
| <29% of $V_{CC}$       | -60°                              | 15% $V_{CC}$               |
| 29% to 45% of $V_{CC}$ | 0°                                | 37% $V_{CC}$               |
| 45% to 62% of $V_{CC}$ | 90°                               | 53% $V_{CC}$               |
| 62% of $V_{CC}$        | 180°                              | $V_{CC}$                   |

## Two Phase Parallel Mode Operation

TABLE 7. OPERATION MODE SETTING FOR 6.5V AND 7.5V OUTPUT APPLICATION

| V <sub>IN</sub> (V) | V <sub>O</sub> (V) | OPERATION MODE | PHASE SHIFT BETWEEN PHASES | VSEN2- | VSEN2+ | CLKOUT | VMON2            | MODE |
|---------------------|--------------------|----------------|----------------------------|--------|--------|--------|------------------|------|
| 11 to 13.9          | 6.5                | 5A             | 180°                       | VCC    | N/C    | N/C    | VMON1 OR DIVIDER | SGND |
| 13.9 to 15.6        | 6.5                | 6              | 240°                       | VCC    | SGND   | N/C    | 953Ω//22nF       | VCC  |
| 15.6 to 20          | 6.5                | 5A             | 180°                       | VCC    | N/C    | N/C    | VMON1 OR DIVIDER | SGND |
| 11 to 15            | 7.5                | 5A             | 180°                       | VCC    | N/C    | N/C    | VMON1 OR DIVIDER | SGND |
| 15 to 20            | 7.5                | 6              | 240°                       | VCC    | SGND   | N/C    | 953Ω//22nF       | VCC  |

When ISL8225M operates in 2-phase mode, the current sensing and sharing circuit keeps each channel's current in balance. After a typical 175nS blanking period, with respect to the falling edge of the PWM pulse of each channel, the voltage developed across  $r_{DS(ON)}$  of the low side MOSFETs is filtered and sampled as the sensed current. If the other phase's high-side MOSFET is turned on right at the moment when current is sensed, the switching noise can distort the sensed current signal, which may result in low frequency output ripple. For high output voltage of >5V, the low frequency ripple is worse due to higher switching noise at higher input voltage. Because of the 175ns current sensing blanking time, if the second channel has 180° phase lag with respect to the first channel, the low frequency ripple typically appears when the module operates at around 40% duty cycle depending upon switching frequency. To solve this problem, 240° phase shift (Mode 6 of [Table 3](#)) can be used instead of the 180° phase shift (Mode 5A of [Table 3](#)). [Figure 23](#) shows a typical application with 240° phase shift.

All other conditions equal, the module with 180° phase shift has lower input ripple and output ripple than the module with 240° phase shift, thus the selection of the optimum operation mode should be based on the input voltage. [Table 7](#) shows the operation mode selection to avoid low frequency for 6.5V and 7.5V output applications with 750kHz switching frequency. Please refer to [Table 3](#) on [page 21](#) for more information about each operation mode.

### Layout Guide

To achieve stable operation, low losses, and good thermal performance, some layout considerations are necessary ([Figure 34](#)).

- VOUT1, VOUT2, PHASE1, PHASE2, PGND, VIN1 and VIN2 should have large, solid planes. Place enough thermal vias to

connect the power planes in different layers under or around the module.

- Place high-frequency ceramic capacitors between VIN, VOUT, and PGND, as closely to the module as possible in order to minimize high-frequency noise.
- Use remote sensed traces to the regulation point to achieve tight output voltage regulation, and keep the sensing traces close to each other in parallel.
- PHASE1 and PHASE2 pads are switching nodes that generate switching noise. Keep these pads under the module. For noise-sensitive applications, it is recommended to keep phase pads only on the top and inner layers of the PCB. Also, do not place phase pads exposed to the outside on the bottom layer of the PCB.
- Avoid routing any noise-sensitive signal traces, such as the VSEN+, VSEN-, ISHARE, COMP and VMON sensing points, near the PHASE pins.
- Use a separated SGND ground copper area for components connected to signal ground pins. Connect SGND to PGND with multiple vias underneath the unit in one location to avoid the noise coupling, as shown in [Figure 34](#). Don't ground vias surrounded by the noisy planes of VIN, PHASE and VOUT. For dual output applications, the SGND to PGND vias are preferred to be as close as possible to SGND pin.
- Optional snubbers can be put on the bottom side of the board layout, connecting the PHASE to PGND planes, as shown in [Figure 34](#).

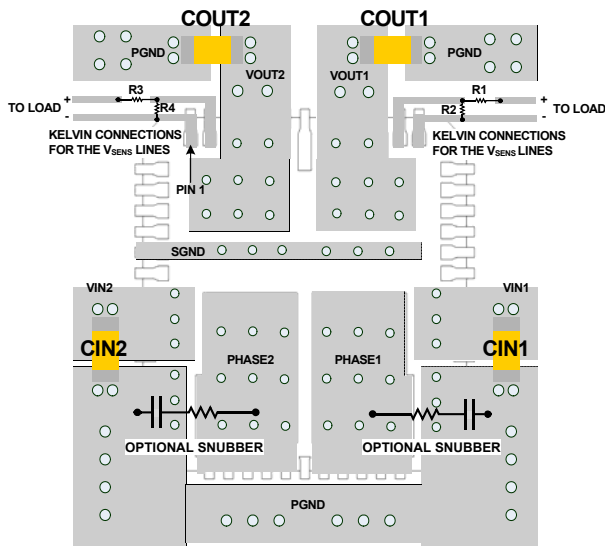

FIGURE 34. RECOMMENDED LAYOUT

## Current Derating

Experimental power loss curves (Figures 35 and 36), along with  $\theta_{JA}$  from thermal modeling analysis, can be used to evaluate the thermal consideration for the module. Derating curves are derived from the maximum power allowed while maintaining temperature below the maximum junction temperature of +120 °C (Figures 37 through 42). The maximum +120 °C junction temperature is considered for the module to load the current consistently and it provides the 5 °C margin of safety from the rated junction temperature of +125 °C. If necessary, customers can adjust the margin of safety according to the real applications. All derating curves are obtained from the tests on the ISL8225MEVAL4Z evaluation board. In the actual application, other heat sources and design margins should be considered.

## Package Description

The ISL8225M is integrated into a quad flatpack no lead package (QFN). This package has such advantages as good thermal and electrical conductivity, low weight, and small size. The QFN package is applicable for surface mounting technology and is becoming more common in the industry. The ISL8225M contains several types of devices, including resistors, capacitors, inductors, and control ICs. The ISL8225M is a copper lead-frame based package with exposed copper thermal pads, which have good electrical and thermal conductivity. The copper lead frame and multi-component assembly are over-molded with polymer mold compound to protect these devices.

The package outline, typical PCB layout pattern, and typical stencil pattern design are shown in the L26.17x17 package outline drawing on page 28. Figure 48 shows typical reflow profile parameters. These guidelines are general design rules. Users can modify parameters according to specific applications.

## PCB Layout Pattern Design

The bottom of ISL8225M is a lead-frame footprint, which is attached to the PCB by surface mounting. The PCB layout pattern is shown in the L26.17x17 package outline drawing on page 33. The PCB layout pattern is essentially 1:1 with the QFN exposed pad and the I/O termination dimensions, except that the PCB lands are slightly longer than the QFN terminations by about 0.2mm (0.4mm max). This extension allows for solder filletting around the package periphery and ensures a more complete and inspectable solder joint. The thermal lands on the PCB layout should match 1:1 with the package exposed die pads.

## Thermal Vias

A grid of 1.0mm to 1.2mm pitched thermal vias, which drops down and connects to buried copper planes, should be placed under the thermal land. The vias should be about 0.3mm to 0.33mm in diameter, with the barrel plated to about 2.0 ounce copper. Although adding more vias (by decreasing pitch) improves thermal performance, it also diminishes results as more vias are added. Use only as many vias as are needed for the thermal land size and as your board design rules allow.

## Stencil Pattern Design

Reflowed solder joints on the perimeter I/O lands should have about a 50µm to 75µm (2mil to 3mil) standoff height. The solder paste stencil design is the first step in developing optimized, reliable solder joints. The stencil aperture size to land size ratio should typically be 1:1. Aperture width may be reduced slightly to help prevent solder bridging between adjacent I/O lands.

To reduce solder paste volume on the larger thermal lands, an array of smaller apertures instead of one large aperture is recommended. The stencil printing area should cover 50% to 80% of the PCB layout pattern. A typical solder stencil pattern is shown in the L26.17x17 package outline drawing on page 33. The gap width between pads is 0.6mm. Consider the symmetry of the whole stencil pattern when designing the pads.

A laser-cut, stainless-steel stencil with electropolished trapezoidal walls is recommended. Electropolishing smooths the aperture walls, resulting in reduced surface friction and better paste release, which reduces voids. Using a trapezoidal section aperture (TSA) also promotes paste release and forms a brick-like paste deposit, which assists in firm component placement. A 0.1mm to 0.15mm stencil thickness is recommended for this large-pitch (1.0mm) QFN.

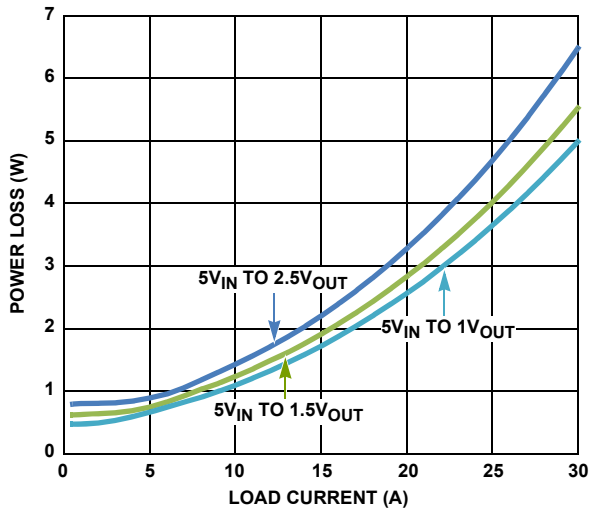

FIGURE 35. POWER LOSS CURVES OF 5V<sub>IN</sub>

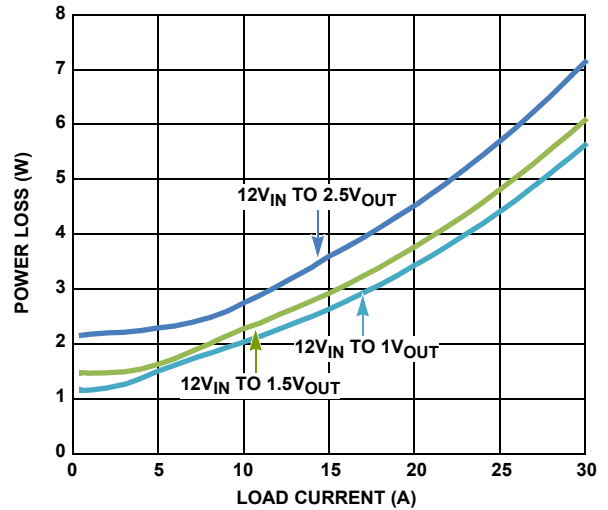

FIGURE 36. POWER LOSS CURVES OF 12V<sub>IN</sub>

**Derating Curves** All of the following curves were plotted at T<sub>J</sub> = +125°C.

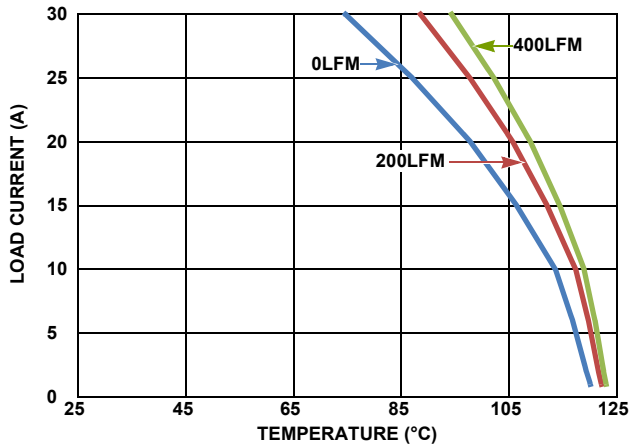

FIGURE 37. DERATING CURVE 5V TO 1V

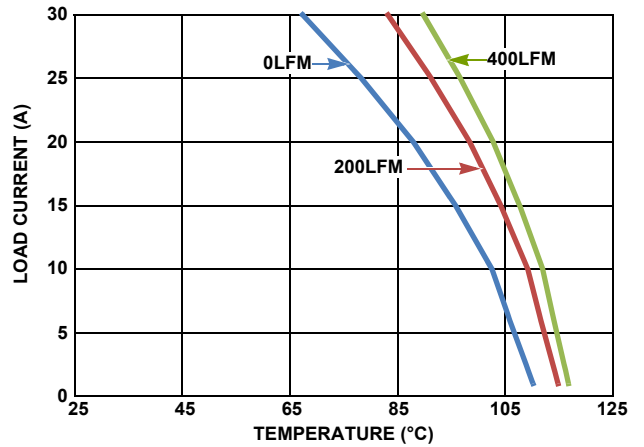

FIGURE 38. DERATING CURVE 12V TO 1V

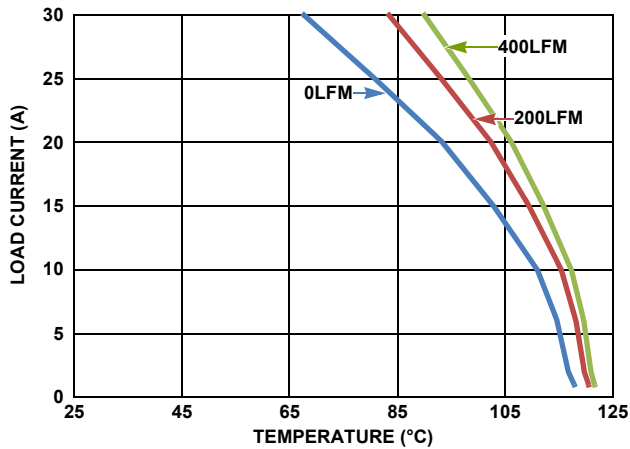

FIGURE 39. DERATING CURVE 5V TO 1.5V

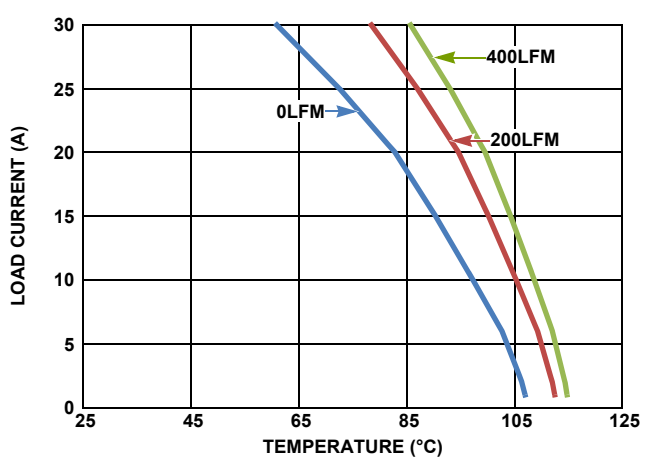

FIGURE 40. DERATING CURVE 12V TO 1.5V

**Derating Curves** All of the following curves were plotted at  $T_j = +125^\circ\text{C}$ . (Continued)

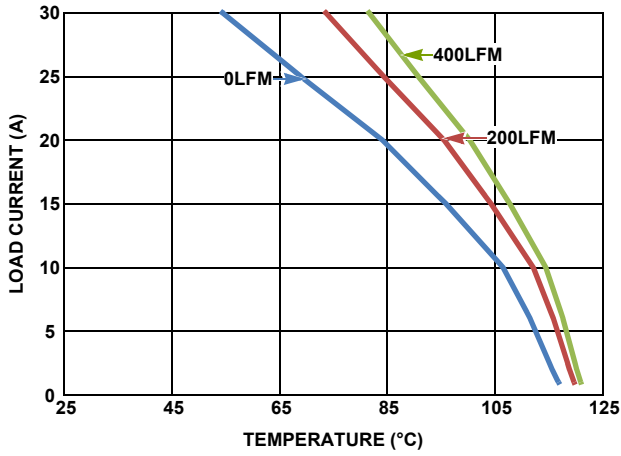

FIGURE 41. DERATING CURVE 5V TO 2.5V

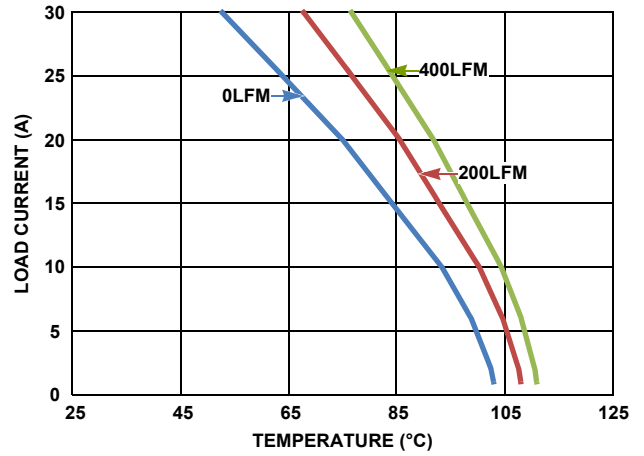

FIGURE 42. DERATING CURVE 12V TO 2.5V

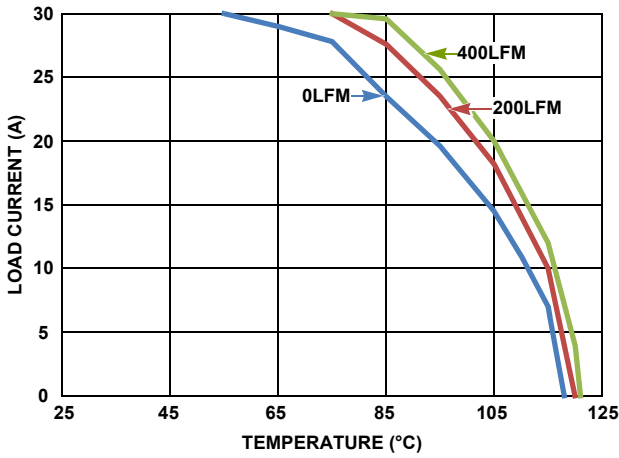

FIGURE 43. DERATING CURVE 5V/3.3V

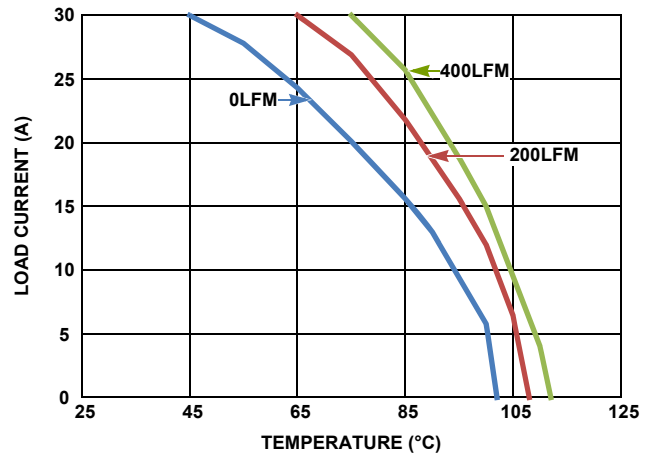

FIGURE 44. DERATING CURVE 12V/3.3V

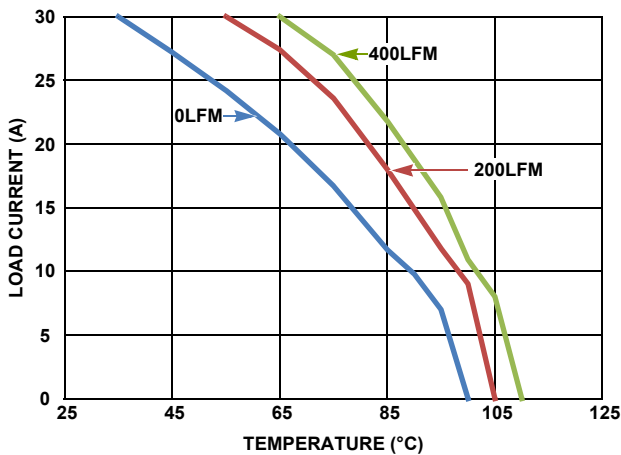

FIGURE 45. DERATING CURVE 12V/5V

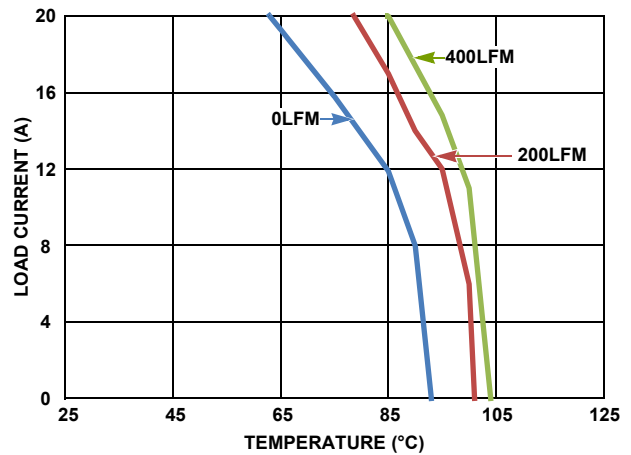

FIGURE 46. DERATING CURVE 12V/6.5V

**Derating Curves** All of the following curves were plotted at  $T_J = +125^\circ\text{C}$ . (Continued)

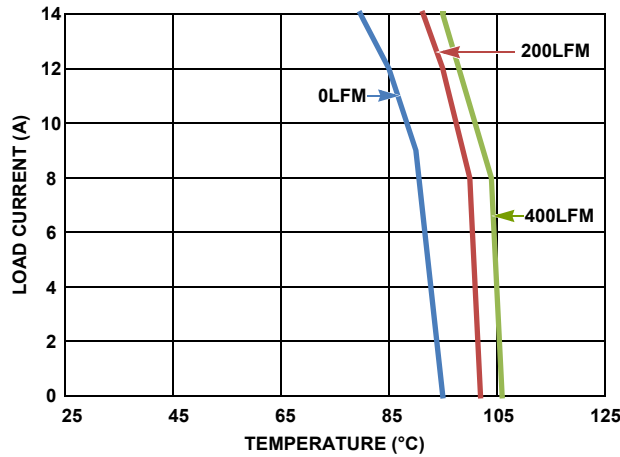

FIGURE 47. DERATING CURVE 12V/7.5V

**Reflow Parameters**

Due to the low mount height of the QFN, "No Clean" Type 3 solder paste, per ANSI/J-STD-005, is recommended. Nitrogen purge is also recommended during reflow. A system board reflow profile depends on the thermal mass of the entire populated board, so it is not practical to define a specific soldering profile just for the QFN. The profile given in Figure 43 is provided as a guideline to customize for varying manufacturing practices and applications.

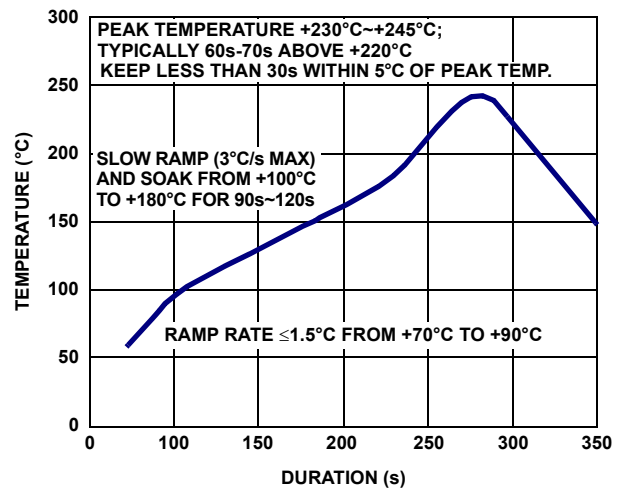

FIGURE 48. TYPICAL REFLOW PROFILE

© Copyright Intersil Americas LLC 2012-2014. All Rights Reserved.  
 All trademarks and registered trademarks are the property of their respective owners.

For additional products, see [www.intersil.com/en/products.html](http://www.intersil.com/en/products.html)

Intersil products are manufactured, assembled and tested utilizing ISO9001 quality systems as noted in the quality certifications found at [www.intersil.com/en/support/qualandreliability.html](http://www.intersil.com/en/support/qualandreliability.html)

*Intersil products are sold by description only. Intersil may modify the circuit design and/or specifications of products at any time without notice, provided that such modification does not, in Intersil's sole judgment, affect the form, fit or function of the product. Accordingly, the reader is cautioned to verify that datasheets are current before placing orders. Information furnished by Intersil is believed to be accurate and reliable. However, no responsibility is assumed by Intersil or its subsidiaries for its use; nor for any infringements of patents or other rights of third parties which may result from its use. No license is granted by implication or otherwise under any patent or patent rights of Intersil or its subsidiaries.*

For information regarding Intersil Corporation and its products, see [www.intersil.com](http://www.intersil.com)

## Revision History

The revision history provided is for informational purposes only and is believed to be accurate, but not warranted. Please go to web to make sure you have the latest revision.

| DATE             | REVISION | CHANGE   |
|------------------|----------|--|
| December 8, 2014 | FN7822.2 | <ul style="list-style-type: none"> <li>-Features on page 1: changed the output voltage range: from: "0.6V to 6V to: "0.6V to 7.5V.</li> <li>-Features on page 1: Updated 17mm square PCB footprint to: 17mmx17mm square PCB footprint.</li> <li>-Ordering information table on page 4 added part numbers: ISL8225MEVAL2Z, ISL8225MEVAL3Z, ISL8225MEVAL4Z.</li> <li>-Pin description on page 6, updated the output voltage range for pin numbers 23, 25: from: 0.6V to 6V To: 0.6V to 7.5V.</li> <li>-Recommended Operation table on page 7, updated output voltage range: from 0.6V to 6V to: 0.6V to 7.5V.</li> <li>-Electrical spec table on page 7 under "VCC voltage level" section, updated Min from 5.15V to 5.1V and Max from 5.95V to 5.6V.</li> <li>-Electrical spec table on page 8 as follow:<br/>"Synchronization frequency s" section: Updated Min from 150kHz to 300kHz.<br/>Under Load Regulation Accuracy: Added a 0.3 typ value to IOUT1 and IOUT2 sections.<br/>Under REFERENCE section: Added Min 0.5958 and Max 0.6042 to VREF1.<br/>Under REFERENCE section: Added Min 0.5955 and Max 0.6057 to VREF2.</li> <li>-Typical performance characteristics on page 10: Update Figures 4 and 5 with 6.5V/7.5V data.</li> <li>-Updated the title for Figure 19 on page 13.</li> <li>-Updated the title for Figures 21 on page 14.</li> <li>-Added Figure 22 and 23 on page 15.</li> <li>-Updated Table 1 on page 19: Added rows 33, 34, 35, 36, 37, 38, 39, 40.</li> <li>-Table 2 on page 20: Added a row for 47µF 10V ceramic cap.</li> <li>-Table 3 on page 21 under Vmon2 section: Updated mode 6, 7A, 7B and 7C: from 1kΩ to 0.953Ω/ 22nF and updated note 14.<br/>Updated Table 4 on page 22: Added two rows for 6.5V and 7.5V values.</li> <li>-"Programming the Output Voltage" on page 22: Added a text with 6.5V and 7.5V information.</li> <li>-"Current Share" on page 25: changed the VMON2 value, From: 1.0k to 953Ω.</li> <li>-Section "Tracking Function" on page 26: Updated equation 7.</li> <li>-Table 5 on page 26: Added a row with 240°.</li> <li>-Table 6 on page 26 by Adding "CHANNEL 2" to checkout WRT and updated: "29% to 45% of VCC" section from 90° to 0° and "45% to 62% of VCC" section from 120° to 90°.</li> <li>On page 27: Added "Two Phase Parallel Mode" operation section.</li> <li>-Added Table 7 on page 27.</li> <li>-Updated Derating Curves on page 29.</li> <li>-On page 29 the title for "Derating Curves" updated: <math>T_J = +120^\circ\text{C}</math> to <math>T_J = +125^\circ\text{C}</math>.</li> </ul> |
| January 4, 2013  | FN7822.1 | <p>"Thermal Information" on page 7:<br/>Changed "Maximum Storage Temperature Range" from "-40°C to +150°C" to "-55°C to +150°C"</p> <p>"Selection of Input Capacitor" on page 22:<br/>Added "<math>f_{SW}</math>" to Equation 2. Added "<math>f_{SW}</math> is the switching frequency (Hz)"</p>   |
| December 3, 2012 | FN7822.0 | Initial Release  |

## About Intersil

Intersil Corporation is a leading provider of innovative power management and precision analog solutions. The company's products address some of the largest markets within the industrial and infrastructure, mobile computing and high-end consumer markets.

For the most updated datasheet, application notes, related documentation and related parts, please see the respective product information page found at [www.intersil.com](http://www.intersil.com).

You may report errors or suggestions for improving this datasheet by visiting [www.intersil.com/ask](http://www.intersil.com/ask).

Reliability reports are also available from our website at [www.intersil.com/support](http://www.intersil.com/support)



# Package Outline Drawing

## L26.17x17

26 LEAD QUAD FLAT NO-LEAD PLASTIC PACKAGE (PUNCH QFN)

Rev 4, 10/12

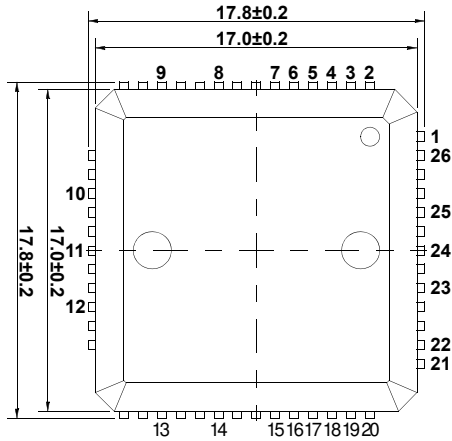

TOP VIEW

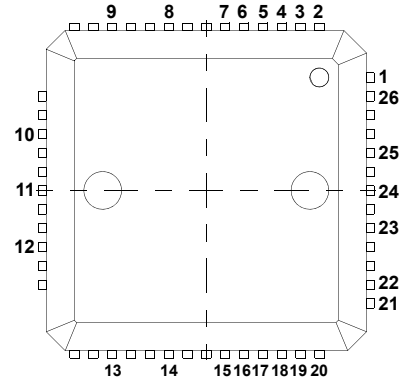

PIN NO. DEFINITION (TOP VIEW)

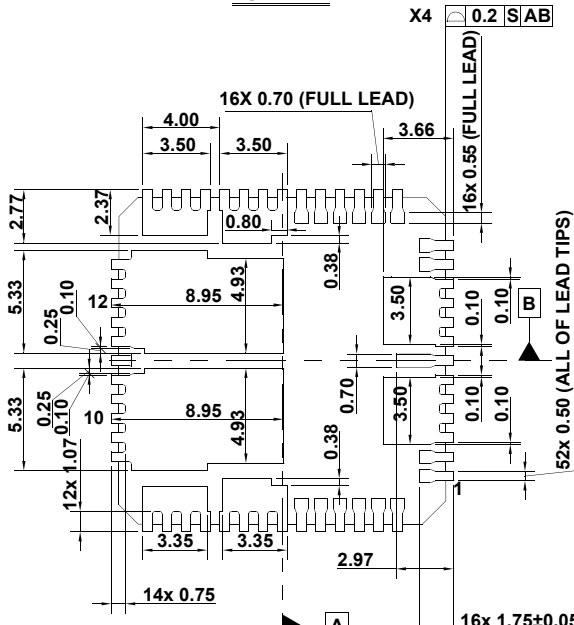

BOTTOM VIEW

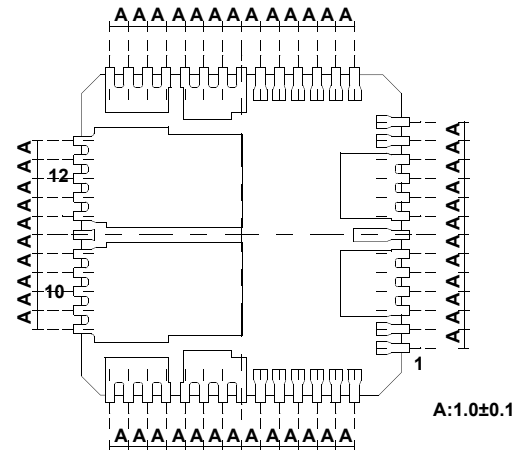

PIN-TO-PIN DISTANCE (BOTTOM VIEW)

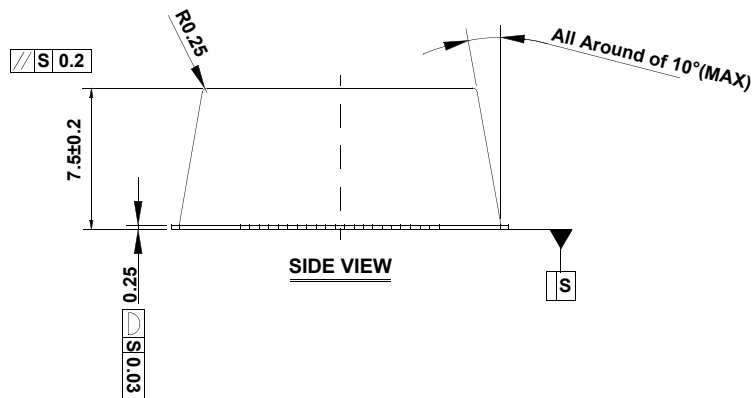

SIDE VIEW

