



# STMPE1601

## 16-bit enhanced port expander with keypad and PWM controller Xpander Logic™

### Features

- 16 GPIOs (8 operate at core supply  $V_{CC}$ , 8 operate at IO supply  $V_{IO}$ )
- Operating voltage 1.8 –3.3 V
- Hardware keypad controller (8\*8 matrix with 4 optional dedicated keys max)
- Keypad controller capable of detecting key-press in hibernation mode
- 4 basic PWM controllers for LED brightness control
- Interrupt output (open drain) pin
- Optional 32 kHz clock input
- 8-channel programmable level translator
- Advanced power management system
- Ultra-low standby-mode current
- Package TFBGA25 (3 x 3 mm)

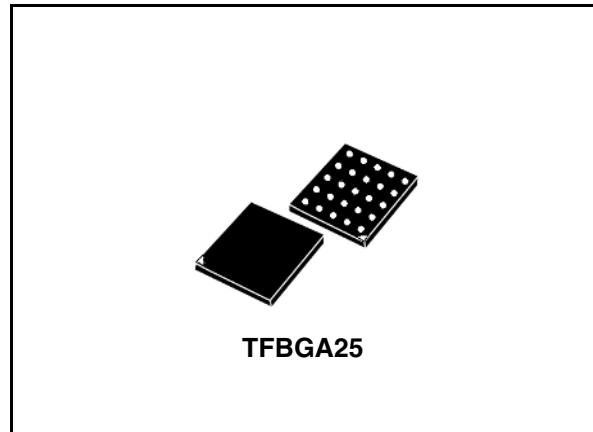

### Description

The STMPE1601 is a GPIO (general purpose input/output) port expander able to interface a main digital ASIC via the two-line bidirectional bus ( $I^2C$ ). A separate GPIO expander IC is often used in mobile multimedia platforms to solve the problems of the limited number of GPIOs typically available on the digital engine.

The STMPE1601 offers great flexibility, as each I/O can be configured as input, output or specific functions. The device is able to scan a keyboard, also provides PWM outputs for brightness control in backlight, and GPIO function. This device has been designed to include very low quiescent current, and a wake-up feature for each I/O, to optimize the power consumption of the IC.

Potential applications of the STMPE1601 include portable media players, game consoles, mobile and smart phones.

Table 1. Device summary

Order code	Package	Packaging
STMPE1601TBR	TFBGA25	Tape and reel

# Contents

- 1      Block diagram ..... 4**
- 2      Pin settings ..... 5**
  - 2.1 Pin connection ..... 5
  - 2.2 Pin assignment and TFBGA ball location ..... 5
  - 2.3 Ball mapping to TFBGA (top through view) ..... 6
  - 2.4 GPIO pin functions ..... 7
- 3      Maximum rating ..... 8**
  - 3.1 Absolute maximum rating ..... 8
  - 3.2 Thermal data ..... 8
- 4      Electrical specification ..... 9**
  - 4.1 DC electrical characteristics ..... 9
  - 4.2 Input/Output DC electrical characteristics ..... 10
- 5      Register map ..... 11**
- 6      I2C interface ..... 12**
  - 6.1 Minimizing current drain on I2C address lines ..... 13
  - 6.2 Start condition ..... 14
  - 6.3 Stop condition ..... 14
  - 6.4 Acknowledge bit (ACK) ..... 14
  - 6.5 Data input ..... 14
  - 6.6 Slave device address ..... 14
  - 6.7 Memory addressing ..... 14
  - 6.8 Operating modes ..... 15
  - 6.9 General call address ..... 16
- 7      System controller ..... 17**
  - 7.1 States of operation ..... 20
  - 7.2 Autosleep ..... 21
  - 7.3 Keypress detect in the hibernate mode ..... 21

<b>8</b>	<b>Clocking system</b> .....	<b>22</b>
8.1	Clock source .....	22
8.2	Power mode programming sequence .....	23
<b>9</b>	<b>Interrupt system</b> .....	<b>24</b>
9.1	Interrupt system register map .....	24
9.1.1	Interrupt latency .....	25
9.2	Programming sequence .....	30
<b>10</b>	<b>GPIO controller</b> .....	<b>31</b>
10.1	GPIO control registers .....	32
10.2	GPIO alternate function registers .....	33
10.3	Hotkey feature .....	34
10.3.1	Programming sequence for Hotkey .....	34
10.3.2	Minimum pulse width .....	34
10.4	Level translator feature .....	35
<b>11</b>	<b>Basic PWM controller</b> .....	<b>36</b>
11.1	Interrupt on basic PWM controller .....	42
11.2	Trigger feature .....	42
<b>12</b>	<b>Keypad controller</b> .....	<b>43</b>
12.1	Keypad configurations .....	44
12.2	Keypad controller registers .....	46
<b>13</b>	<b>Data registers</b> .....	<b>50</b>
<b>14</b>	<b>Keypad combination key registers</b> .....	<b>53</b>
<b>15</b>	<b>Miscellaneous features</b> .....	<b>56</b>
15.1	Reset .....	56
<b>16</b>	<b>Package mechanical data</b> .....	<b>57</b>
<b>17</b>	<b>Revision history</b> .....	<b>61</b>

# 1 Block diagram

Figure 1. STMPE1601 block diagram

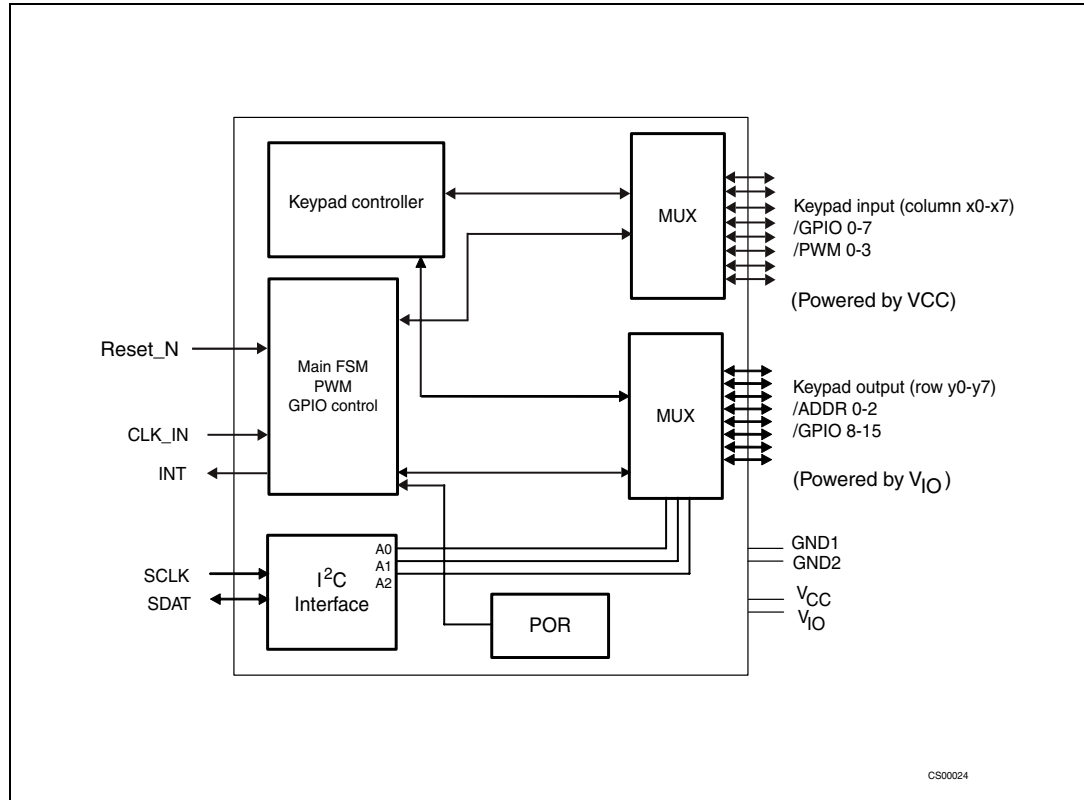

## 2 Pin settings

### 2.1 Pin connection

Figure 2. Pin connection (top-through view)

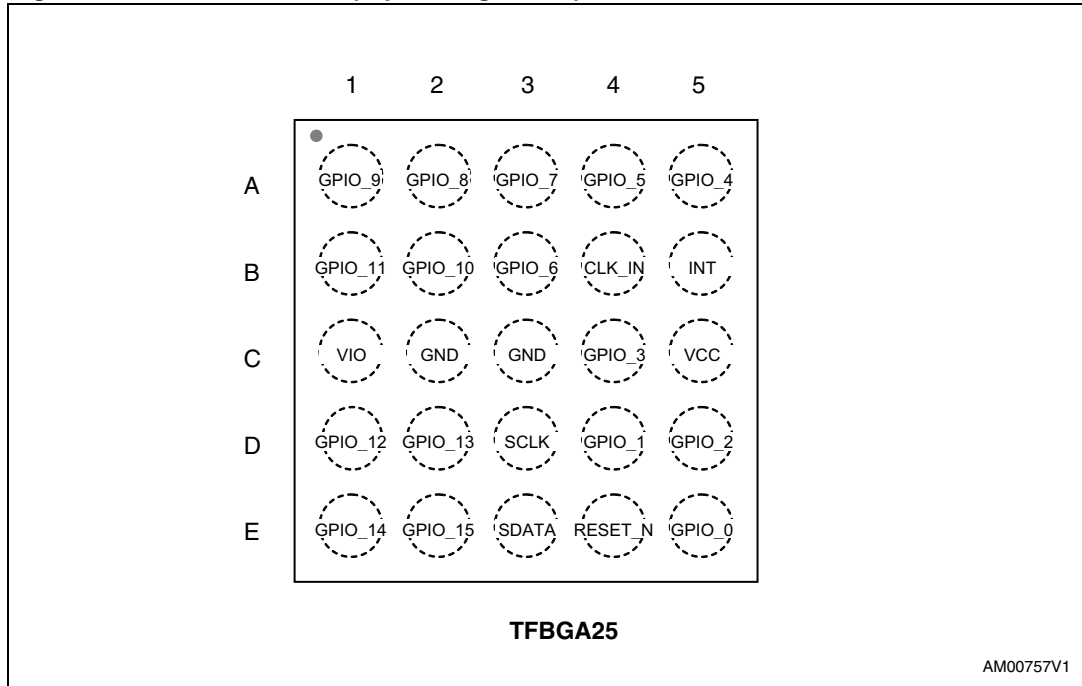

### 2.2 Pin assignment and TFBGA ball location

Table 2. Pin assignment

Ball name	Name	Type	Domain	Description
E5	GPIO_0	I/O	V <sub>CC</sub>	GPIO 0/ KP_X0/ PWM_0
D4	GPIO_1	I/O	V <sub>CC</sub>	GPIO 1/ KP_X1/ PWM_1
D5	GPIO_2	I/O	V <sub>CC</sub>	GPIO 2/ KP_X2/ PWM_2
C4	GPIO_3	I/O	V <sub>CC</sub>	GPIO 3/ KP_X3/ PWM_3
A5	GPIO_4	I/O	V <sub>CC</sub>	GPIO 4/ KP_X4
A4	GPIO_5	I/O	V <sub>CC</sub>	GPIO 5/ KP_X5
B3	GPIO_6	I/O	V <sub>CC</sub>	GPIO 6/ KP_X6
A3	GPIO_7	I/O	V <sub>CC</sub>	GPIO 7/ KP_X7
A2	GPIO_8	I/O	V <sub>IO</sub>	GPIO 8/ KP_Y0
A1	GPIO_9	I/O	V <sub>IO</sub>	GPIO 9/ KP_Y1
B2	GPIO_10	I/O	V <sub>IO</sub>	GPIO 10/ KP_Y2

Table 2. Pin assignment (continued)

Ball Name	Name	Type	Domain	Description
B1	GPIO_11	IO	V <sub>IO</sub>	GPIO 11/ KP_Y3
D1	GPIO_12	IO	V <sub>IO</sub>	GPIO 12/ KP_Y4
D2	GPIO_13	IO	V <sub>IO</sub>	GPIO 13/ KP_Y5/ ADDR0
E1	GPIO_14	IO	V <sub>IO</sub>	GPIO 14/ KP_Y6/ ADDR1
E2	GPIO_15	IO	V <sub>IO</sub>	GPIO 15/ KP_Y7/ ADDR2
B5	INT	O	V <sub>CC</sub>	Open drain interrupt output pin. INT pin to be externally pulled up to V <sub>CC</sub> (or > V <sub>CC</sub> , < 3.6 V), or pulled down to GND, depending on polarity of interrupt (must not be left floating).
E4	Reset_N	I	V <sub>CC</sub>	External reset input, active LOW. Reset_N pulse width must be ≥ 20 μs. This pin is internally pulled up to V <sub>CC</sub> .
E3	SDATA	A	V <sub>CC</sub>	I <sup>2</sup> C DATA (tolerant to 3.6 V)
D3	SCLK	A	V <sub>CC</sub>	I <sup>2</sup> C clock (tolerant to 3.6 V)
B4	CLK_IN	A	V <sub>CC</sub>	32 kHz input. To be pulled-up to V <sub>CC</sub> with 10 k resistor if clock is not used. This pin is internally pulled to V <sub>CC</sub> .
C5	VCC	–	–	1.8 –3.3 V input for I <sup>2</sup> C module and digital core
C1	VIO	–	–	1.8 –3.3 V input for GPIO. The VIO must be ≥ V <sub>CC</sub> .
C2	GND	–	–	Ground
C3	GND	–	–	Ground

## 2.3 Ball mapping to TFBGA (top through view)

Table 3. Pin mapping

	1	2	3	4	5
A	GPIO_9	GPIO_8	GPIO_7	GPIO_5	GPIO_4
B	GPIO_11	GPIO_10	GPIO_6	CLK_IN	INT
C	VIO	GND	GND	GPIO_3	VCC
D	GPIO_12	GPIO_13	SCLK	GPIO_1	GPIO_2
E	GPIO_14	GPIO_15	SDATA	RESET_N	GPIO_0

## 2.4 GPIO pin functions

Table 4. GPIO pin functions

Name	Primary function	Alternate function 1	Alternate function 2	Note
GPIO_0	GPIO	Keypad	PWM	–
GPIO_1	GPIO	Keypad	PWM	–
GPIO_2	GPIO	Keypad	PWM	–
GPIO_3	GPIO	Keypad	PWM	–
GPIO_4	GPIO	Keypad	–	–
GPIO_5	GPIO	Keypad	–	–
GPIO_6	GPIO	Keypad	–	–
GPIO_7	GPIO	Keypad	–	–
GPIO_8	GPIO	Keypad	–	–
GPIO_9	GPIO	Keypad	–	–
GPIO_10	GPIO	Keypad	–	–
GPIO_11	GPIO	Keypad	–	–
GPIO_12	GPIO	Keypad	–	–
GPIO_13	GPIO	Keypad	–	I <sup>2</sup> C ADDR during RESET
GPIO_14	GPIO	Keypad	–	I <sup>2</sup> C ADDR during RESET
GPIO_15	GPIO	Keypad	–	I <sup>2</sup> C ADDR during RESET

### 3 Maximum ratings

Stressing the device above the rating listed in the “Absolute maximum ratings” table may cause permanent damage to the device. These are stress ratings only and operation of the device at these or any other conditions above those indicated in the Operating sections of this specification is not implied. Exposure to absolute maximum rating conditions for extended periods may affect device reliability.

#### 3.1 Absolute maximum ratings

**Table 5. Absolute maximum ratings**

Symbol	Parameter	Value	Unit
$V_{CC}$	Supply voltage	4.5	V
$V_{IN}$	Input voltage on GPIO pin	4.5	V
VESD (HBM)	ESD protection on each GPIO pin	2	kV

#### 3.2 Thermal data

**Table 6. Thermal data**

Symbol	Parameter	Min	Typ	Max	Unit
$R_{thJA}$	Thermal resistance junction-ambient	-	100	-	°C/W
$T_A$	Operating ambient temperature	-40	25	85	°C
$T_J$	Operating junction temperature	-40	25	125	°C



## 4 Electrical specification

### 4.1 DC electrical characteristics

Table 7. DC electrical characteristics

Symbol	Parameter	Test conditions	Value			Unit
			Min	Typ	Max	
$V_{CC}$	1.8 V supply voltage		1.65	–	3.6	V
$V_{IO}$	IO supply voltage		1.65	–	3.6	V
$I_{CC}$	Active current	$V_{IO} V_{CC} = 1.8\text{ V}$ $T = 25\text{ }^{\circ}\text{C}$	–	1.2	1.6	mA
$I_{SLEEP}$	Sleep current		–	18	25	$\mu\text{A}$
$I_{HIBERNATE}$	Hibernate current		–	0.5	1.5	$\mu\text{A}$
$I_{CC}$	Active current	$V_{IO} V_{CC} = 3.3\text{ V}$ $T = 25\text{ }^{\circ}\text{C}$	–	3.0	3.8	mA
$I_{SLEEP}$	Sleep current		–	50	60	$\mu\text{A}$
$I_{HIBERNATE}$	Hibernate current <sup>(1)</sup>		–	1.2	3	$\mu\text{A}$
$I_{CC}$	Active current	$V_{IO} V_{CC} = 1.8\text{ V}$ $T = 85\text{ }^{\circ}\text{C}$	–	–	2	mA
$I_{SLEEP}$	Sleep current		–	–	32	$\mu\text{A}$
$I_{HIBERNATE}$	Hibernate current		–	–	2	$\mu\text{A}$
$I_{CC}$	Active current	$V_{IO} V_{CC} = 3.3\text{ V}$ $T = 85\text{ }^{\circ}\text{C}$	–	–	4.8	mA
$I_{SLEEP}$	Sleep current		–	–	75	$\mu\text{A}$
$I_{HIBERNATE}$	Hibernate current <sup>(1)</sup>		–	–	5	$\mu\text{A}$
INT	Open drain output current		–	4	–	mA

1. If only the basic GPIO function is required, the STMPE1601 can be designed to work mostly in hibernate mode. Active mode is used only when there are changes in the I/O status.

## 4.2 Input/Output DC electrical characteristics

The 1.8 V I/O complies to the EIA/JEDEC standard JESD8-7.

**Table 8. I/O DC electrical characteristic**

Symbol	Parameter		Value			Unit
			Min	Typ	Max	
$V_{il}$	Low level input voltage	$V_{IO} = 1.8 \text{ V}$	–	–	0.63	V
$V_{ih}$	High level input voltage	$V_{IO} = 1.8 \text{ V}$	1.17	–	–	V
$V_{hyst}$	Schmitt trigger hysteresis	$V_{IO} = 1.8 \text{ V}$	–	0.10	–	V
$V_{il}$	Low level input voltage	$V_{IO} = 3.3 \text{ V}$	–	–	1.15	V
$V_{ih}$	High level input voltage	$V_{IO} = 3.3 \text{ V}$	2.14	–	–	V
$V_{hyst}$	Schmitt trigger hysteresis	$V_{IO} = 3.3 \text{ V}$	–	0.20	–	V

**Table 9. DC input specification ( $1.55 \text{ V} < V_{CC} < 1.95 \text{ V}$ )**

Symbol	Parameter	Test conditions	Value			Unit
			Min	Typ	Max	
$V_{ol}$	Low level output voltage	$I_{ol} = 4 \text{ mA}$ $V_{IO} = 1.8 \text{ V}$	–	–	0.45	V
$V_{oh}$	High level output voltage	$I_{oh} = 4 \text{ mA}$ $V_{IO} = 1.8 \text{ V}$	1.35	–	–	V
$V_{ol}$	Low level output voltage	$I_{ol} = 4 \text{ mA}$ $V_{IO} = 3.3 \text{ V}$	–	–	0.83	V
$V_{oh}$	High level output voltage	$I_{oh} = 4 \text{ mA}$ $V_{IO} = 3.3 \text{ V}$	2.48	–	–	V

**Table 10. DC output specification ( $1.55 \text{ V} < V_{CC} < 1.95 \text{ V}$ )**

Symbol	Parameter	Test conditions	Value			Unit
			Min	Typ	Max	
$I_{pu}$	Pull-up current	$V_I = 0 \text{ V}$	15	35	65	$\mu\text{A}$
$R_{up}^{(1)}$	Equivalent pull-up resistance	$V_{CC} = 3.3 \text{ V}$	30	60	90	$\text{k}\Omega$
		$V_{CC} = 1.8 \text{ V}$	50	100	150	$\text{k}\Omega$
$R_{up}^{(2)}$	Equivalent pull-up resistance	$V_{IO} = 3.3 \text{ V}$	30	60	90	$\text{k}\Omega$
		$V_{IO} = 1.8 \text{ V}$	50	100	150	$\text{k}\Omega$

1. Applicable to GPIO\_0 to GPIO\_7.

2. Applicable to GPIO\_8 to GPIO\_15.

## 5 Register map

All the registers have the size of 8-bit. For each of the module, their registers are residing within the given address range.

**Table 11. Register map summary table**

Address	Module register	Description	Auto-increment (during read/write)
0x00 – 0x07 0x80 – 0x81	Clock and power manager module	Clock and power manager register range	Yes
0x10 – 0x1F	Interrupt controller module	Interrupt controller register range	Yes
0x40 – 0x5F	PWM controller module	PWM controller register range	Yes
0x60 – 0x6F	Keypad controller module	Keypad controller register range	Yes
0x70 – 0x77	Rotator controller module	Rotator controller register range	Yes
0x80 – 0xBF	GPIO controller module	GPIO controller register range	Yes

## 6 I<sup>2</sup>C interface

The features supported by the I<sup>2</sup>C interface are listed below:

- I<sup>2</sup>C slave device
- Operates at V<sub>CC</sub> (1.8 - 3.3 V)
- Compliant to Philips I<sup>2</sup>C specification version 2.1
- Supports standard (up to 100kbps) and fast (up to 400 kbps) modes
- 7-bit and 10-bit device addressing modes
- General Call
- Start/Restart/Stop
- Address up to 8 STMPE1601 devices via the I<sup>2</sup>C interface

The address is selected by the state of 3 pins. The state of the pins is read upon reset and then the pins can be configured for normal operation. The pins have a pull-up or pull-down to set the address. The I<sup>2</sup>C interface module allows the connected host system to access the registers in the STMPE1601.

**Table 12. I<sup>2</sup>C addresses**

A2	A1	A0	7-bit address
0	0	0	40h
0	0	1	41h
0	1	0	42h
0	1	1	43h
1	0	0	44h
1	0	1	45h
1	1	0	46h
1	1	1	47h

## 6.1 Minimizing current drain on I<sup>2</sup>C address lines

The GPIOs 13-15 are used as I<sup>2</sup>C address input during POR. Pull-up/down resistor of 500 kΩ - 1.5 MΩ is recommended for these address lines. In the case that these pins are driven to an opposite logic level during device operation, there would be a current drain of  $V_{IO}/R$ . This amounts to a significant current drain for portable devices.

To minimize the current drain on I<sup>2</sup>C lines, two methods are recommended:

1. If maximum keypad size is not required, these shared lines should not be used for keypad operation.
2. If the maximum keypad size is required, choose I<sup>2</sup>C address 0x40, as this requires all 3 address lines to be pulled to ground, minimizing the current drain in the keypad operation. In this mode of operation, the recommended pull up/down resistors on the I<sup>2</sup>C lines are listed in [Table 13](#).

A reset circuit with longer RC is used to ensure enough time for the address lines to settle to the final values.

3. In system-controlled idle state, all the keypad pins are to be configured as hotkey with interrupt function enabled. If any key is pressed, the system initiates the keypad controller for scanning operation.

**Table 13. Recommended pull up/down resistors on the I<sup>2</sup>C lines**

Pull up/down resistor	V <sub>IO</sub>			Reset RC or pulse width <sup>(1)</sup>	Note
	1.8 V	2.5 V	3.3 V		
R <sub>PU</sub> /R <sub>PD</sub>	1.5 MΩ	1.2 MΩ	1 MΩ	270 kΩ/0.47 μF 120 ms	All 3 address lines are used for keypad controller
R <sub>PU</sub> /R <sub>PD</sub>	1.0 MΩ	800 kΩ	660 kΩ	180 kΩ/0.47 μF 80 ms	2 address lines are used for keypad controller
R <sub>PU</sub> /R <sub>PD</sub>	500 kΩ	400 kΩ	330 kΩ	90kΩ/0.47 μF 40 ms	1 address line is used for keypad controller

1. Recommended values are chosen to minimize leakage current.

## 6.2 Start condition

A Start condition is identified by a falling edge of SDATA while SCLK is stable at high state. A Start condition must precede any data/command transfer. The device continuously monitors for a Start condition and does not respond to any transaction unless one is encountered.

## 6.3 Stop condition

A Stop condition is identified by a rising edge of SDATA while SCLK is stable at high state. A Stop condition terminates the communication between the slave device and bus master. A read command that is followed by NoAck can be followed by a Stop condition to force the slave device into idle mode. When the slave device is in idle mode, it is ready to receive the next I<sup>2</sup>C transaction. A Stop condition at the end of a write command stops the write operation to the registers.

## 6.4 Acknowledge bit (ACK)

The acknowledge bit is used to indicate a successful byte transfer. The bus transmitter releases the SDATA after sending eight bits of data. During the ninth bit, the receiver pulls the SDATA low to acknowledge the receipt of the eight bits of data. The receiver may leave the SDATA in high state if it would to not acknowledge the receipt of the data.

## 6.5 Data input

The device samples the data input on SDATA on the rising edge of the SCLK. The SDATA signal must be stable during the rising edge of SCLK and the SDATA signal must change only when SCLK is driven low.

## 6.6 Slave device address

The slave device address is a 7 or 10-bit address, where the least significant 3-bit are programmable. These 3-bit values will be loaded in once upon reset and after that these 3 pins no longer be needed with the exception during General Call. Up to 8 STMPE1601 devices can be connected on a single I<sup>2</sup>C bus.

## 6.7 Memory addressing

For the bus master to communicate to the slave device, the bus master must initiate a Start condition and followed by the slave device address. Accompanying the slave device address, there is a Read/Write bit ( $\overline{R/W}$ ). The bit is set to 1 for Read and 0 for Write operation.

If a match occurs on the slave device address, the corresponding device gives an acknowledgement on the SDA during the 9<sup>th</sup> bit time. If there is no match, it deselects itself from the bus by not responding to the transaction.

## 6.8 Operating modes

Table 14. Operating modes

Mode	Bytes	Programming sequence
Read	≥1	START, Device address, R/W = 0, Register address to be read
		reSTART, Device address, R/W = 1, Data Read, STOP
		If no STOP is issued, the Data Read can be continuously performed. If the register address falls within the range that allows address auto-increment, then register address auto-increments internally after every byte of data being read. For register address that falls within a non-incremental address range, the address will be kept static throughout the entire read operations. Refer to the <a href="#">Table 11: Register map summary table on page 11</a> for the address ranges that are auto and non-increment. An example of such a non-increment address is FIFO.
Write	≥1	START, Device address, R/W = 0, Register address to be written, Data Write, STOP.
		If no STOP is issued, the Data Write can be continuously performed. If the register address falls within the range that allows address auto-increment, then register address auto-increments internally after every byte of data being written. For those register addresses that fall within a non-incremental address range, the address will be kept static throughout the all write operations. Refer to the memory map table for the address ranges that are auto and non-increment. An example of a non-increment address is Data Port for initializing the PWM commands.

Figure 3. I<sup>2</sup>C transaction

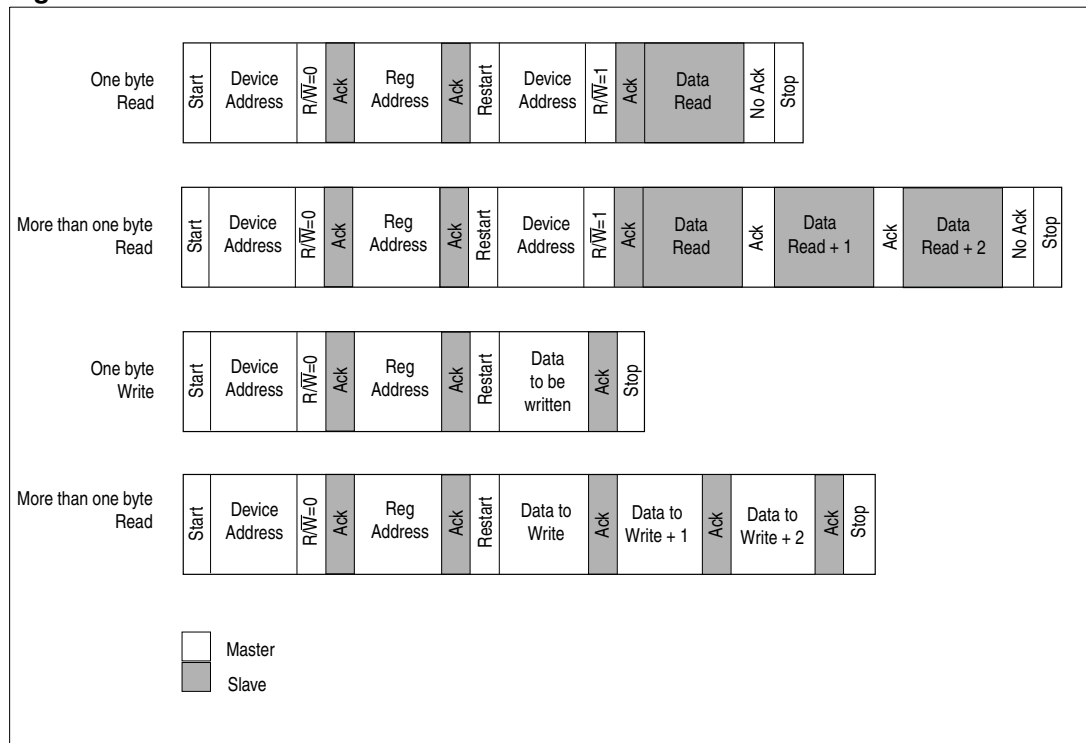

## 6.9 General call address

A general call address is a transaction with the slave address of 0x00 and  $R/\overline{W} = 0$ . When a general call address is made, the STMPE1601 responds to this transaction with an acknowledgement and behaves as a slave-receiver mode. The meaning of a general call address is defined in the second byte sent by the master-transmitter.

**Table 15. General call address**

$R/\overline{W}$	Second byte value	Definition
0	0x06	A 2-byte transaction in which the second byte tells the slave device to reset and write (or latch in) the 2-bit programmable part of the slave address.
0	0x04	A 2-byte transaction in which the second byte tells the slave device not to reset and write (or latch in) the 2-bit programmable part of the slave address.
0	0x00	Not allowed as second byte.

*Note:* All other second byte values will be ignored.



## 7 System controller

The system controller is the heart of the STMPE1601. It contains the registers for power control and chip identification.

The system registers are:

**Table 16. System registers**

Address	Register name
0x80	CHIP_ID
0x81	VERSION_ID
0x02	SYS_CTRL
0x03	SYS_CTRL_2

### CHIP\_ID

### Chip identification register

7	6	5	4	3	2	1	0
8-bit CHIP_ID							
R	R	R	R	R	R	R	R
0	0	0	0	0	0	1	0

### VERSION\_ID

### Version identification register

7	6	5	4	3	2	1	0
8-bit VERSION_ID							
R	R	R	R	R	R	R	R
0	0	0	1	0	0	1	0

**SYS\_CTRL****System control register**

7	6	5	4	3	2	1	0
SOFT_RESET	CLOCK SOURCE	DIS_32KHz	SLEEP	EN_GPIO	RESERVED	EN_KPC	EN_SPWM
W	RW	RW	RW	RW	R	RW	RW
0	0	0	0	1	1	1	1

**Address:** 0x02

**Type:** R/W

**Reset:** 0x0F

**Description:** System control register.

[7] **SOFT\_RESET**

Writing a '1' to this bit will do a soft reset of the device. Once the reset is done, this bit will be cleared to '0' by the HW.

[6] **CLOCK\_SOURCE**

Set to '1' if external 32 kHz clock were to be used. '0' by default.

[5] **DIS\_32 kHz:**

Set this bit to disable the 32 kHz OSC, thus putting the device in hibernate mode.

[4] **SLEEP:**

Writing a '1' to this bit will put the device in sleep mode. On going to sleep mode, this mode is reset internally. When in sleep mode, the internal RC oscillator will output a slower sleep clock which will be used in the device.

[3] **EN\_GPIO:**

Writing a '0' to this bit will gate off the clock to the GPIO module, thus stopping its operation

[2] **RESERVED**

[1] **EN\_KPC:**

Writing a '0' to this bit will gate off the clock to the keypad controller module, thus stopping its operation

[0] **EN\_SPWM**

Writing a '0' to this bit will gate off the clock to the simple PWM controller module, thus stopping its operation

**SYS\_CTRL\_2**

**System control register 2**

7	6	5	4	3	2	1	0
RESERVED		VIO_OFF		AUTOSLEEP_EN	SLEEP_2	SLEEP_1	SLEEP_0
R		R		RW	RW	RW	RW
0		0		0	0	0	0

**Address:** 0x03

**Type:** R/W

**Reset:** 0x00

**Description:** System control register.

[7] **RESERVED**

[6] **RESERVED**

[5] **RESERVED**

[4] **VIO\_OFF:**

Writing a '1' to this bit is mandatory before shutting off the V<sub>IO</sub> supply while maintaining the V<sub>CC</sub> supply.

This ensure that the level shifters for GPIOs 15-8 are properly powered down so as not to induce high current and also not to affect the integrity of any external signals that are on the bus where these GPIOs are connected.

[3] **AUTOSLEEP\_EN:**

"1" to enable auto-sleep feature. "0" to disable auto-sleep.

[2:0] **SLEEP:**

- 000 for 4 ms delay
- 001 for 16 ms delay
- 010 for 32 ms delay
- 011: for 64 ms delay
- 100: for 128 ms delay
- 101: for 256 ms delay
- 110: for 512 ms delay
- 111: for 1024 ms delay

## 7.1 States of operation

Figure 4. Modes of operation

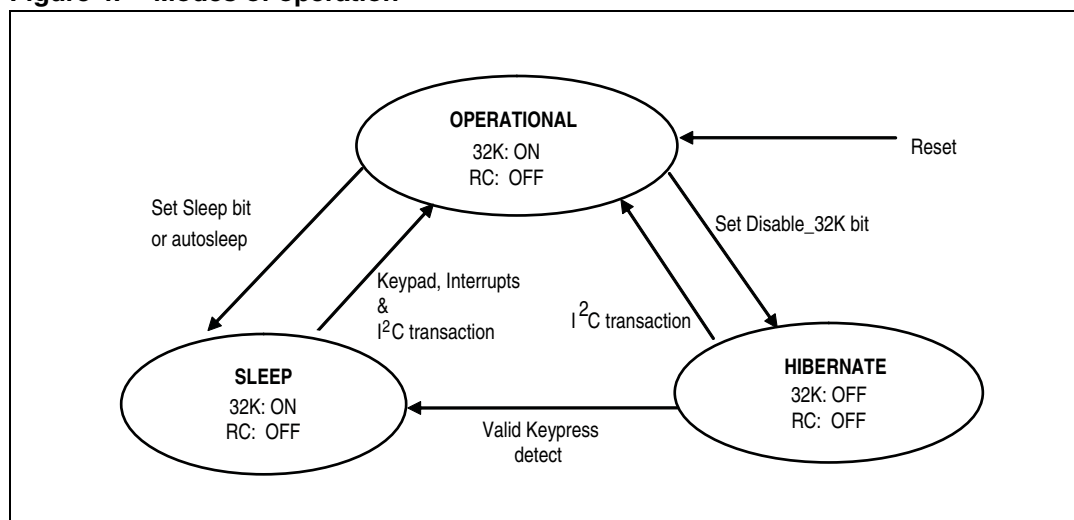

The device has three main modes of operation:

- **Operational mode:** This is the mode, whereby normal operation of the device takes place. In this mode, the RC clock is available and the main FSM unit routes this clock and the 32 kHz clock to all the device blocks that are enabled. In this mode, individual blocks that need not to be working can be turned off by the master by programming the bits 3 to 0 of the SYS\_CTRL register.
- **Sleep mode:** In this low-power mode, the RC oscillator is powered down. All the blocks which need clocks derived from the 32 kHz clock will continue getting a 32 kHz clock. In this mode also, individual blocks can be turned off by the master by programming the bits 3 to 0 of the SYS\_CTRL register. However, the master needs to program the SYS\_CTRL register before coming into this mode, as in the sleep mode, the I<sup>2</sup>C interface is not active except to detect traffic for wakeup. Any activity on the I<sup>2</sup>C port (intended I<sup>2</sup>C transaction for the device) or Wakeup pin or Hotkey activity will cause the device to leave this mode and go into the Operational mode. When leaving this mode, the I<sup>2</sup>C will need to hold the SCLK till the RC clock is ready.
- **Hibernate mode:** This mode is entered when the system writes a '1' to bit 5 of the SYS\_CTRL register. In this mode, the device is completely inactive as there is absolutely no clock. Only a Reset or a wakeup on I<sup>2</sup>C will bring back the system to operational mode. A keypress detect will bring the system to Sleep mode, in which the debounce of the key will take place.

*Note:* The 32 kHz clock mentioned in this section can be (1) an externally fed 32 kHz clock, or (2) an internally generated (from RC OSC) clock. In case the internal clock is used, the clock has a range of 25 to 45 kHz.

## 7.2 Autosleep

The host system may configure the STMPE1601 to go into sleep mode automatically whenever there is a period of inactivity following a complete I<sup>2</sup>C transaction with the STMPE1601. This inactivity means there is no intended I<sup>2</sup>C transaction for the device. For example, if there is an I<sup>2</sup>C transaction sent by the host to other slave devices, the STMPE1601 device will still be counting down for the auto-sleep. The STMPE1601 device resets the autosleep time-out counter only when it receives an I<sup>2</sup>C transaction meant for the device itself. This autosleep feature is controlled by the SYS\_CTRL\_2 (system control register 2).

All those events that trigger an interrupt (KPC, hot-key) would result in a transition from Sleep state to Operational state automatically. The wakeup can also be performed through the I<sup>2</sup>C transaction intended for the device.

## 7.3 Keypress detect in the hibernate mode

When in Hibernate mode, a keypress detect causes the system to go into sleep mode. The sleep clock (32 kHz) is then used to debounce the key to detect a valid key. If the keypress is detected to be valid, the system stays in sleep mode. If the key is detected to be invalid, the system goes back into Hibernate mode.

## 8 Clocking system

Figure 5. Clocking system

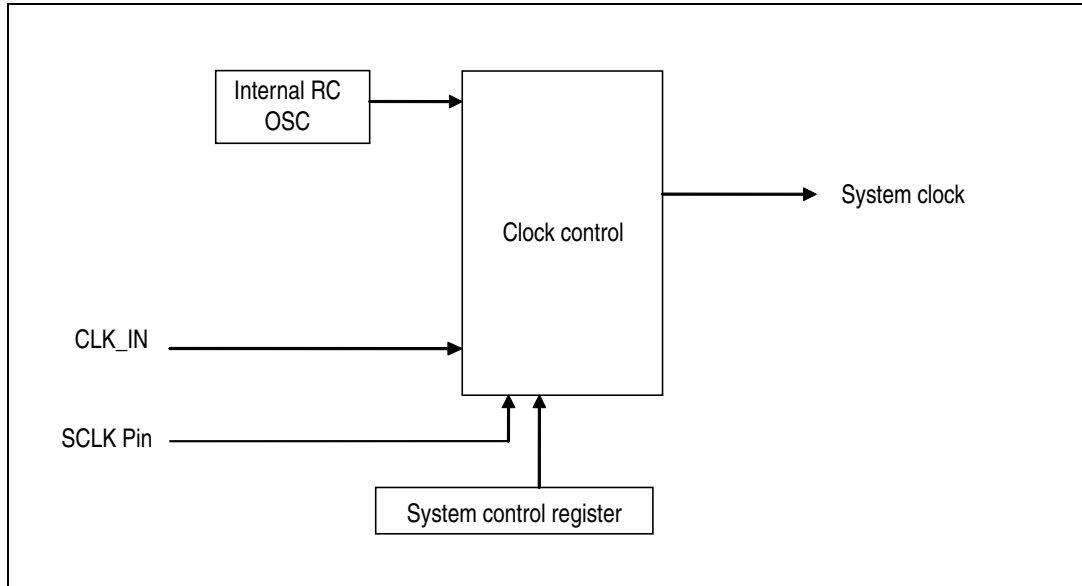

The decision on clocks is based on the bits written into the SYS\_CTRL registers. Bits 0 to 3 of the SYS\_CTRL register allow to control the gating of clocks to the keypad controller, PWM and GPIO in the operational mode.

### 8.1 Clock source

By default, when the STMPE1601 powers up, it derives a 32 kHz clock from the internal RC oscillator for its operation. If an external clock source is available, it must be configured to accept an external clock through the SYS\_CTRL register.

There are 4 sources of reset:

- Reset\_N pin
- Low voltage detect (LVD) reset
- Soft reset bit of the SYS\_CTRL register
- I<sup>2</sup>C reset from the I<sup>2</sup>C block.

## 8.2 Power mode programming sequence

To put the device in sleep mode, the following needs to be done by the host:

- Write a '1' to bit 4 of the SYS\_CTRL register.

To wake up the device, the host is required to:

- Assert a wakeup routine on the I<sup>2</sup>C bus by sending the Start bit, followed by the device address and the Write bit. Subsequently, proceed with sending the Base Register address and continue with a normal I<sup>2</sup>C transaction. The device wakes up upon receiving the correct device address and in Write direction. In other words, the procedure of waking up the device is performed by just sending an I<sup>2</sup>C transaction to the device. This procedure can be extended to wake up the device that is in hibernate mode.

To do a soft reset to the device, the host needs to do the following:

- Write a '1' to bit 7 of the SYS\_CTRL register. This bit is automatically cleared upon reset.

To go into Hibernate mode, the following needs to be done by the host:

- Set the Disable\_32K bit to '1'

To come out of the Hibernate mode, the following needs to be done by the host:

- Assert a system reset
- or put a wakeup on the I<sup>2</sup>C

## 9 Interrupt system

The STMPE1601 uses a highly flexible interrupt system. It allows the host system to configure the type of system events that should result in an interrupt, and pinpoints the source of interrupt by status register. The INT pin can be configured as ACTIVE HIGH, or ACTIVE LOW.

Once asserted, the INT pin would de-assert only if the corresponding bit in the interrupt status register is cleared.

**Figure 6. Interrupt system**

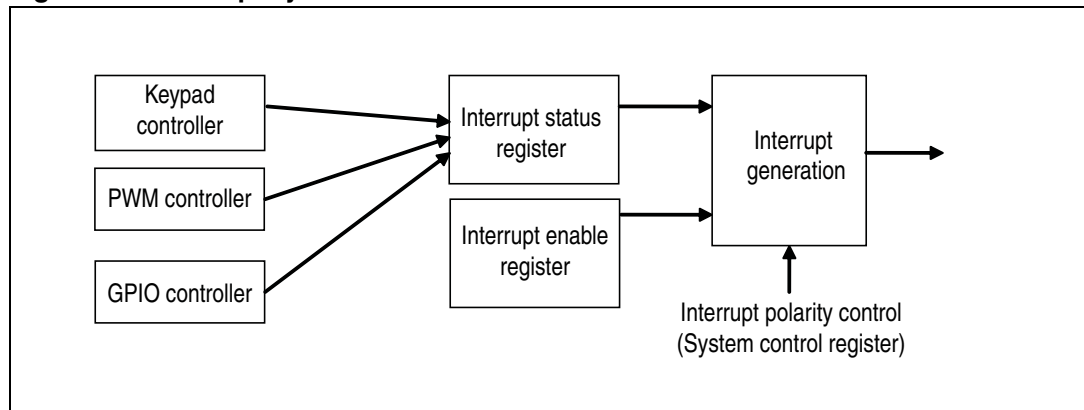

### 9.1 Interrupt system register map

**Table 17. Register map**

Address	Register name	Description	Auto-increment (during sequential R/W)
0x10	INT_CTRL_MSB	Interrupt control register	Yes
0x11	INT_CTRL_LSB		Yes
0x12	INT_EN_MASK_MSB	Interrupt enable mask register	Yes
0x13	INT_EN_MASK_LSB		Yes
0x14	INT_STA_MSB	Interrupt status register	Yes
0x15	INT_STA_LSB		Yes
0x16	INT_EN_GPIO_MASK_MSB	Interrupt enable GPIO mask register	Yes
0x17	INT_EN_GPIO_MASK_LSB		Yes
0x18	INT_STA_GPIO_MSB	Interrupt status GPIO register	Yes
0x19	INT_STA_GPIO_LSB		Yes



### 9.1.1 Interrupt latency

When the generation of interrupts by the GPIO as input is enabled, the latency (time taken from actual transition at GPIO to time of INT pin assertion) is shown in the following table:

**Table 18. Interrupt latency**

State of operation	Interrupt latency
Hibernation	10 μs max
Sleep	5 μs max
Active	2 μs max

### INT\_CTRL

### Interrupt control register

15	14	13	12	11	10	9	8	7	6	5	4	3	2	1	0
INT_CTRL_msb								INT_CTRL_lsb							
Reserved													IC2	IC1	IC0
R	R	R	R	R	R	R	R	R	R	R	R	R	RW	RW	RW
0	0	0	0	0	0	0	0	0	0	0	0	0	0	0	0

**Address:** 0x10, 0x11

**Type:** R, R/W

**Reset:** 0x00

**Description:** The interrupt control register is used to configure the interrupt controller. It has a global enable interrupt mask bit that controls the interruption to the host.

[15:3] RESERVED

[2] **IC2:** Output Interrupt polarity  
 '0' = Active low/falling edge  
 '1' = Active high/rising edge

[1] **IC1:** Output Interrupt Type  
 '0' = Level interrupt  
 '1' = Edge interrupt

[0] **IC0:** Global Interrupt Mask bit

When this bit is written a '1', it will allow interruption to the host. If it is written with a '0', then, it disables all interruption to the host. Writing to this bit does not affect the INT\_EN\_MASK value.

**INT\_EN\_MASK**

**Interrupt enable mask register**

15	14	13	12	11	10	9	8	7	6	5	4	3	2	1	0
INT_EN_MASK_msb								INT_EN_MASK_lsb							
R	R	R	R	R	R	R	RW	IE7	IE6	IE5	IE4	IE3	IE2	IE1	IE0
0	0	0	0	0	0	0	0	0	0	0	0	0	0	0	0

**Address:** 0x12, 0x13

**Type:** R, R/W

**Reset:** 0x00

**Description:** The interrupt enable mask register is used to enable the interruption from a particular interrupt source to the host.

[15:9] **RESERVED**

[8] **IE[x]:**

Interrupt Enable Mask (where x = 8 to 0)

IE0: Wake-up interrupt mask

IE1: Keypad controller interrupt mask

IE2: Keypad controller FIFO overflow interrupt mask

IE3: Reserved

IE4: Basic PWM controller 0 interrupt mask

IE5: Basic PWM controller 1 interrupt mask

IE6: Basic PWM controller 2 interrupt mask

IE7: Basic PWM controller 3 interrupt mask

IE8: GPIO controller interrupt mask

Writing a '1' to the IE[x] bit enables the interruption to the host.

**INT\_STA**

**Interrupt status register**

15	14	13	12	11	10	9	8	7	6	5	4	3	2	1	0
ISR_msb								ISR_lsb							
							IS8	IS7	IS6	IS5	IS4	IS3	IS2	IS1	IS0
R	R	R	R	R	R	R	RW	RW	RW	RW	RW	RW	RW	RW	RW
0	0	0	0	0	0	0	0	0	0	0	0	0	0	0	0

**Address:** 0x14, 0x15

**Type:** R, R/W

**Reset:** 0x00

**Description:** The interrupt status register monitors the status of the interruption from a particular interrupt source to the host. Regardless whether the INT\_EN bits are enabled or not, the INT\_STA bits are still updated.

[15:9] **RESERVED**

[8:0] **IS[x]:**

Interrupt status (where x = 8 to 0)

Read:

IS0: Wake-up Interrupt Status

IS1: Keypad controller interrupt status

IS2: Keypad controller FIFO overflow interrupt status

IS3: Reserved

IS4: Basic PWM controller 0 interrupt status

IS5: Basic PWM controller 1 interrupt status

IS6: Basic PWM controller 2 Interrupt status

IS7: Basic PWM controller 3 interrupt status

IS8: GPIO Controller Interrupt Status

Write: a write to a IS[x] bit with a value of '1' will clear the interrupt and a write with a value of '0' has no effect on the IS[x] bit.

**INT\_EN\_GPIO\_MASK**

**Interrupt enable GPIO mask register**

15	14	13	12	11	10	9	8	7	6	5	4	3	2	1	0
INT_EN_GPIO_MASK_msb								INT_EN_GPIO_MASK_lsb							
IEG15	IEG14	IEG13	IEG12	IEG11	IEG10	IEG9	IEG8	IEG7	IEG6	IEG5	IEG4	IEG3	IEG2	IEG1	IEG0
RW	RW	RW	RW	RW	RW	RW	RW	RW	RW	RW	RW	RW	RW	RW	RW
0	0	0	0	0	0	0	0	0	0	0	0	0	0	0	0

**Address:** 0x16, 0x17

**Type:** R/W

**Reset:** 0x00

**Description:** The interrupt enable GPIO mask register is used to enable the interruption from a particular GPIO interrupt source to the host. The IEG[15:0] bits are the interrupt enable mask bits correspond to the GPIO[15:0] pins

[15:0] **IEG[x]**: interrupt enable GPIO mask (where x = 15 to 0)  
 Writing a '1' to the IE[x] bit will enable the interruption to the host.

**INT\_STA\_GPIO**

**Interrupt status GPIO register**

15	14	13	12	11	10	9	8	7	6	5	4	3	2	1	0
INT_STA_GPIOR_msb								INT_STA_GPIOR_lsb							
ISG15	ISG14	ISG13	ISG12	ISG11	ISG10	ISG9	ISG8	ISG7	ISG6	ISG5	ISG4	ISG3	ISG2	ISG1	ISG0
RW	RW	RW	RW	RW	RW	RW	RW	RW	RW	RW	RW	RW	RW	RW	RW
0	0	0	0	0	0	0	0	0	0	0	0	0	0	0	0

**Address:** 0x18, 0x19

**Type:** R/W

**Reset:** 0x00

**Description:** The interrupt status GPIO register monitors the status of the interruption from a particular GPIO pin interrupt source to the host. Regardless whether the INT\_EN\_GPIO\_MASK bits are enabled or not, the INT\_STA\_GPIO bits are still updated. The INT\_STA\_G[15:0] bits are the interrupt status bits correspond to the GPIO[15:0] pins.

[15:0] **ISG[x]**  
 Interrupt status GPIO (where x = 15 to 0)

**Read:**  
 Interrupt status of the GPIO[x].

**Write:**  
 A write to a ISG[x] bit with a value of '1' will clear the interrupt and a write with a value of '0' has no effect on the ISG[x] bit.

## 9.2 Programming sequence

To configure and initialize the interrupt controller to allow interruption to host, observe the following steps:

1. Set the INT\_EN\_MASK and INT\_EN\_GPIO\_MASK registers to the desired values to enable the interrupt sources that are to be expected to receive from.
2. Configure the output interrupt type and polarity and enable the global interrupt mask by writing to the INT\_CTRL.
3. Wait for interrupt.
4. Upon receiving an interrupt, the INT pin is asserted.
5. The host comes to read the INT\_STA register through the I<sup>2</sup>C interface. A '1' in the INT\_STA bits indicates that the corresponding interrupt source is triggered.
6. If the IS8 bit in INT\_STA register is set, the interrupt is coming from the GPIO controller. Then, a subsequent read is performed on the INT\_STA\_GPIO register to obtain the interrupt status of all 16 GPIOs to locate the GPIO that triggers the interrupt. This is a feature so-called 'Hot Key'.
7. After obtaining the interrupt source that triggers the interrupt, the host performs the necessary processing and operations related to the interrupt source.
8. If the interrupt source is from the GPIO Controller, two write operations with value of '1' are performed to the ISG[x] bit (INT\_STA\_GPIO) and the IS[8] (INT\_STA) to clear the corresponding GPIO interrupt.
9. If the interrupt source is from other module, a write operation with value of '1' is performed to the IS[x] (INT\_STA) to clear the corresponding interrupt.
10. Once the interrupt is being cleared, the INT pin will also be de-asserted if the interrupt type is level interrupt. An edge interrupt will only assert a pulse width of 250ns.
11. When the interrupt is no longer required, the IC0 bit in INT\_CTRL may be set to '0' to disable the global interrupt mask bit.

# 10 GPIO controller

A total of 16 GPIOs are available in the STMPE1601 port expander device. Most of the GPIOs are sharing physical pins with some alternate functions. The GPIO controller contains the registers that allow the host system to configure each of the pins into either a GPIO, or one of the alternate functions. Unused GPIOs should be configured as outputs to minimize the power consumption.

**Table 19. GPIO controller (Base address = 0 x 80)**

Offset address	Register name	Description	Auto-increment (during sequential R/W)
0x02	GPIO_SET_MSB	GPIO set pin state register	Yes
0x03	GPIO_SET_LSB		Yes
0x04	GPIO_CLR_msb	GPIO clear pin state register	Yes
0x05	GPIO_CLR_LSB		Yes
0x06	GPIO_MP_MSB	GPIO monitor pin state register	Yes
0x07	GPIO_MP_LSB		Yes
0x08	GPIO_SET_DIR_MSB	GPIO set pin direction register	Yes
0x09	GPIO_SET_DIR_LSB		Yes
0x0A	GPIO_ED_MSB	GPIO edge detect status register	Yes
0x0B	GPIO_ED_LSB		Yes
0x0C	GPIO_RE_MSB	GPIO rising edge register	Yes
0x0D	GPIO_RE_LSB		Yes
0x0E	GPIO_FE_MSB	GPIO falling edge register	Yes
0x0F	GPIO_FE_LSB		Yes
0x10	GPIO_PULL_UP_MSB	GPIO pull up register	Yes
0x11	GPIO_PULL_UP_LSB		Yes
0x12	GPIO_AF_U_MSB	GPIO alternate function register (upper word)	Yes
0x13	GPIO_AF_U_LSB		Yes
0x14	GPIO_AF_L_MSB	GPIO alternate function register (lower word)	Yes
0x15	GPIO_AF_L_LSB		Yes
0x16	GPIO_LT_EN	GPIO level translator enable	Yes
0x17	GPIO_LT_DIR	GPIO level translator direction	Yes
0x18-1F	RESERVED	Reserved	Yes

## 10.1 GPIO control registers

A group of registers is used to control the exact function of each of the 16 GPIOs.

All the GPIO registers are named as GPIO\_xxx\_yyy, where:

- xxx represents the functional group
- yyy represents the byte position of the GPIO
- lsb registers control GPIO[7:0]
- msb registers control GPIO[8:15]

**Table 20. Bit description**

	7	6	5	4	3	2	1	0
GPIO_xxx_msb	IO-15	IO-14	IO-13	IO-12	IO-11	IO-10	IO-9	IO-8
GPIO_xxx_lsb	IO-7	IO-6	IO-5	IO-4	IO-3	IO-2	IO-1	IO-0

The function of each bit is shown in the following table:

**Table 21. Register description**

Register name	Description	Function
GPIO_MP_yyy	GPIO monitor pin state	Reading this bit yields the current state of the bit. Writing has no effect.
GPIO_SET_yyy	GPIO set pin state	Writing '1' to this bit causes the corresponding GPIO to go to '1' state. Writing '0' has no effect.
GPIO_CLR_yyy	GPIO clear pin state	Writing '1' to this bit causes the corresponding GPIO to go to '0' state. Writing '0' has no effect.
GPIO_SET_DIR_yyy	GPIO set pin direction	'0' sets the corresponding GPIO to input state, and '1' sets it to output state
GPIO_ED_yyy	GPIO edge detect status	Set to '1' by hardware when there is a rising/falling edge on the corresponding GPIO. Writing '1' clears the bit. Writing '0' has no effect.
GPIO_RE_yyy	GPIO rising edge	Set to '1' to enable rising edge detection on the corresponding GPIO.
GPIO_FE_yyy	GPIO falling edge	Set to '1' to enable falling edge detection on the corresponding GPIO.
GPIO_PULL_UP_yyy	GPIO pull up	Set to '1' to enable internal pull-up resistor



## 10.2 GPIO alternate function registers

Each GPIO may be configured to one or more functions. A 2-bit field for each GPIO is used for the configuration.

**Table 22. GPIO alternate function registers<sup>(a)</sup>**

GPIO alternate function (upper word)	'00' for primary function '01' for Alternate Function 1
GPIO alternate function (lower word)	'10' for Alternate Function 2 '11' - Reserved

### GPIO\_AF\_U\_yyy

### GPIO alternate function register (upper)

15	14	13	12	11	10	9	8	7	6	5	4	3	2	1	0
AF[1:0]	AF[1:0]	AF[1:0]	AF[1:0]	AF[1:0]	AF[1:0]	AF[1:0]	AF[1:0]	AF[1:0]	AF[1:0]	AF[1:0]	AF[1:0]	AF[1:0]	AF[1:0]	AF[1:0]	AF[1:0]
GPIO-15	GPIO-14	GPIO-13	GPIO-12	GPIO-11	GPIO-10	GPIO-9	GPIO-8								

### GPIO\_AF\_L\_yyy

### GPIO alternate function register (lower)

15	14	13	12	11	10	9	8	7	6	5	4	3	2	1	0
AF[1:0]	AF[1:0]	AF[1:0]	AF[1:0]	AF[1:0]	AF[1:0]	AF[1:0]	AF[1:0]	AF[1:0]	AF[1:0]	AF[1:0]	AF[1:0]	AF[1:0]	AF[1:0]	AF[1:0]	AF[1:0]
GPIO-7	GPIO-6	GPIO-5	GPIO-4	GPIO-3	GPIO-2	GPIO-1	GPIO-0								

a. Refer to [Table 4](#) for alternate function selection.

## 10.3 Hotkey feature

A GPIO is known as 'Hotkey' when it is configured to trigger an interruption to the host whenever the GPIO input is being asserted. This feature is applicable in Operational mode (4 MHz clock is present) as well as in Sleep mode (32 kHz clock is present).

### 10.3.1 Programming sequence for Hotkey

1. Configure the GPIO pin into GPIO mode by setting the corresponding bits in the GPIO alternate function register [GPIO\_AF\_x\_yyy].
2. Configure the GPIO pin into input direction by setting the corresponding bit in the GPIO set pin direction registers [GPIO\_SET\_DIR\_yyy].
3. Set the GPIO rising edge registers [GPIO\_RE\_yyy] and GPIO falling edge registers [GPIO\_FE\_yyy] to the desired values to enable the rising edge or falling edge detection.
4. Configure and enable the interrupt controller to allow the interruption to the host.
5. Now, the GPIO expander may be put into Sleep mode if it is desired.
6. Upon any hot-key being asserted, the device will wake up and issue an interrupt to the host.

Below are the conditions to be fulfilled in order to configure a Hot Key:

1. The pin is configured into GPIO mode and as input pin.
2. The global interrupt mask bit is enabled.
3. The corresponding GPIO interrupt mask bit is enabled.

### 10.3.2 Minimum pulse width

The minimum pulse width of the assertion of the Hotkey must be at least 62.5 us. Any pulse width less than the stated value may not be registered.

## 10.4 Level translator feature

Figure 7. Level translator feature

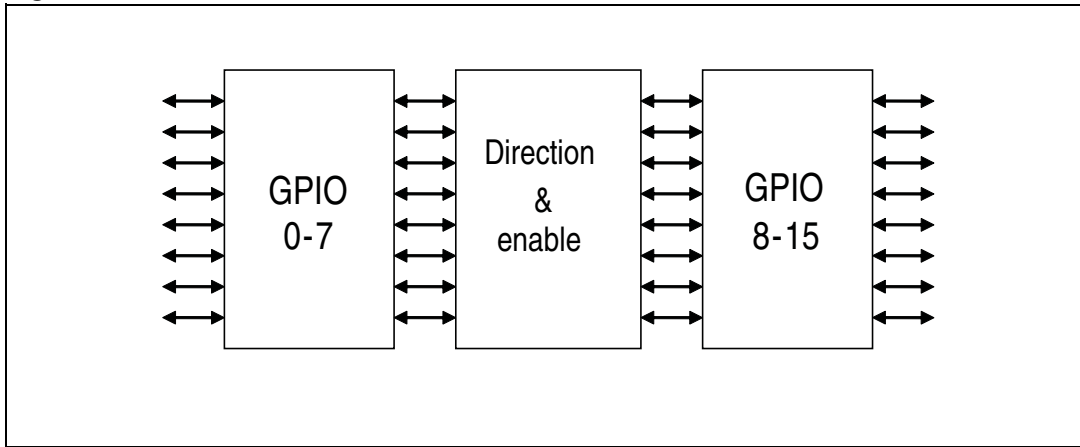

When enabled, the GPIO 0-7 bits are internally mapped to GPIO 8-15 bits. The STMPE1601 becomes an 8-channel level translator where each of the channels may have its direction set individually. As GPIO 0-7 operates from  $V_{CC}$ , and GPIO 8-15 operates from  $V_{IO}$ , this allows the 2 groups of GPIOs to work as a level translator.

---

**Warning:** When the level translator feature is enabled, the “Set pin”, “Clear pin” and “Set direction” bits in the corresponding registers will be ignored. However, the “Monitor pin”, “Edge detect”, “Pull-up” features are still available in the GPIOs used as level translator.

---

## 11 Basic PWM controller

The PWM allows to control the LED brightness and blinking pattern feature.

The STMPE1601 is fitted with a 4-channel basic PWM controller.

**Table 23. Basic PWM controller**

Address	Register name	Description	Auto-increment (during sequential R/W)
0x40	PWM_OFF_OUTPUT	Set the output level when PWM is disabled	Yes
0x41	CHANNEL_FUNCT_EN	Enable/disable individual basic PWM channels	Yes
0x50	PWM_0_SET	PWM_0 brightness and timing setting	Yes
0x51	PWM_0_CTRL	PWM_0 blinking control	Yes
0x52	PWM_0_TRIGGER	Enable use trigger on PWM 0	Yes
0x54	PWM_1_SET	PWM_1 brightness and timing setting	Yes
0x55	PWM_1_CTRL	PWM_1 blinking control	Yes
0x56	PWM_1_TRIGGER	Enable use trigger on PWM 1	Yes
0x58	PWM_2_SET	PWM_2 brightness and timing setting	Yes
0x59	PWM_2_CTRL	PWM_2 blinking control	Yes
0x5A	PWM_2_TRIGGER	Enable use trigger on PWM 2	Yes
0x5C	PWM_3_SET	PWM_3 brightness and timing setting	Yes
0x5D	PWM_3_CTRL	PWM_3 blinking control	Yes
0x5E	PWM_3_TRIGGER	Enable use trigger on PWM 3	Yes

**PWM\_OFF\_OUTPUT**

**PWM off output**

7	6	5	4	3	2	1	0
-	-	-	-	OUT3	OUT2	OUT1	OUT0
RW	RW	RW	RW	RW	RW	RW	RW
0	0	0	0	0	0	0	0

**Address:** 0x40

**Type:** R/W

**Reset:** 0x00

**Description:** Set the output level when the PWM is disabled.

[3:0] **OUTPUT3~0:**

Default is '0'

1: PWM channel outputs '1' when disabled

0: PWM channel outputs '0' when disabled

**CHANNEL\_FUNCT\_EN**

**Channel function enabling**

7	6	5	4	3	2	1	0
ALT_3	ALT_2	ALT_1	ALT_0	EN_3	EN_2	EN_1	EN_0
RW	RW	RW	RW	RW	RW	RW	RW
0	0	0	0	0	0	0	0

**Address:** 0x41

**Type:** R/W

**Reset:** 0x00

**Description:** Enable/disable individual basic PWM channels.

[7:4] **ALT [3:0]:**

Alternate mode

Default is '0'

HW writes to '1' if alternate operating feature (one-shot/watchdog timer) is required

[3:0] **EN [3:0]:**

PWM channel enable

Default is '0'

SW writes '1' to start PWM channel

HW writes '0' when PWM blinking is completed.

SW writes '0' to stop the PWM channel.

**PWM\_n\_TRIGGER**

**PWM trigger register [n = 0 - 3]**

7	6	5	4	3	2	1	0
RESET	Edge	RESERVED	MODE	RELOAD	GS2	GS1	GS0
RW	RW	RW	RW	RW	RW	RW	RW
0	0	0	0	0	0	0	0

**Address:** 0x52, 0x56, 0x5A, 0x5E

**Type:** RW

**Reset:** 0x00

**Description:** Enable use of trigger on PWM\_n.

- [7] **RESET:** Always read '0'  
S/W writes '1' to reset counter in watchdog timer [WDT] mode  
Writing '1' in PWM/one-shot mode has no effect.  
Writing '0' has no effect in all modes.
- [6] **EDGE:** type of logic transition to be detected for trigger source.  
0: low-to-high  
1: hi-to-low
- [5] **RESERVED**
- [4] **MODE:**  
0: one-shot trigger mode  
1: watch-dog timer mode  
This bit is only valid if the ALT bits in the Channel\_function\_En register is set to '1'.
- [3] **RELOAD:**  
'0' for Auto-Reload  
'1' for Manual Reload
- [2:0] **GS2:0:**  
Trigger source select  
000: GPIO-4  
001: GPIO-5  
010: GPIO-6  
011: GPIO-7  
100: GPIO-9  
101: GPIO-10  
110: GPIO-11  
111: GPIO-12

**PWM\_n\_SET**

**PWM setup [n=0-3]**

7	6	5	4	3	2	1	0
Brightness				Timing			
R/W	R/W	R/W	R/W	R/W	R/W	R/W	R/W
0	0	0	0	0	0	0	0

**Address:** 0x50, 0x54, 0x58, 0x5C

**Type:** RW

**Reset:** 0x00

**Description:** PWM blinking control and brightness setting.

[7:4] **BRIGHTNESS:**

- Duty cycle of PWM output during period 0
- 0000: duty cycle ratio 1:15 ( 6.25%, minimum brightness)
- 0001: duty cycle ratio 2:14 (12.50%)
- 0010: duty cycle ratio 3:13 (18.75%)
- 0011: duty cycle ratio 4:12 (25.00%)
- 0100: duty cycle ratio 5:11 (31.25%)
- 0101: duty cycle ratio 6:10 (37.50%)
- 0110: duty cycle ratio 7: 9 (43.75%)
- 0111: duty cycle ratio 8: 8 (50.00%)
- 1000: duty cycle ratio 9: 7 (56.25%)
- 1001: duty cycle ratio 10: 6 (62.50%)
- 1010: duty cycle ratio 11: 5 (68.75%)
- 1011: duty cycle ratio 12: 4 (75.00%)
- 1100: duty cycle ratio 13: 3 (81.25%)
- 1101: duty cycle ratio 14: 2 (87.50%)
- 1110: duty cycle ratio 15: 1 (93.75%)
- 1111: duty cycle ratio 16: 0 (100.00%, maximum brightness)

**[3:0] TIMING:**

In PWM mode: time unit of each ON or OFF period

In watchdog timer mode [WDT]: wait time

In one-shot mode: pulse width

0000 = 5 ms

0001 = 10 ms

0010 = 20 ms

0011 = 40 ms

0100 = 80 ms

0101 = 160 ms

0110 = 320 ms

0111 = 640 ms

1000 = 1280 ms

1001 = 2560 ms

1010 = 5120 ms

1011 = 10 s

1100 = 20 s

1101 = 40 s

1110 = 80 s

1111 = 160 s



**PWM\_n\_CTRL**

**PWM control register [n=0-3]**

7	6	5	4	3	2	1	0
Period 0		Period 1		Repetition		INT_EN	FRAME
RW	RW	RW	RW	RW	RW	RW	RW
0	0	0	0	0	0	0	0

**Address:** 0x51, 0x55, 0x59, 0x5D

**Type:** R/W

**Reset:** 0x00

**Description:** PWM blinking control register

- [7:6] **Period 0:**  
1-4 time units of period 0  
Total length of period 0: (period 0 [1:0] + 1) \* TIMING
- [5:4] **Period 1:**  
0-3 time units of period 1  
Total length of period 1: (period 0 [1:0]) \* TIMING
- [3:2] **Repetition:**  
Number of repetition  
0 for Infinite repetition
- [1] **INT\_EN:**  
"0" to disable interrupt generation on completion of sequence  
"1" to enable interrupt generation on completion of sequence
- [0] **FRAME:**  
'0' will output period 0 first  
'1' will output period 1 first

## 11.1 Interrupt on basic PWM controller

A basic PWM controller can be programmed to generate interrupts at the completion of a blinking sequence. However, there are some limitations:

- a) Each basic PWM controller has its own bit in the interrupt enable/status registers.
- b) If enabled, the completion in any of the PWM controller triggers interrupts. No interrupt will be generated if infinite repetition is set.
- c) In watchdog timer mode [WDT] , an interrupt is generated when timeout occurs
- d) In “one-shot” mode, if “auto-reload”, an interrupt is generated every time a valid trigger is detected. If “non-auto-reload”, an interrupt is generated just once.

## 11.2 Trigger feature

The basic PWM controller can be programmed to be controlled by an external “trigger” signal. This feature can be used to implement:

- One-shot trigger circuits
- Watchdog timers

In one-shot trigger mode, a single pulse whose length is defined by TIMING[3:0] is sent to the PWM output, when a level transition is detected at the trigger source.

In watchdog mode, a 120  $\mu$ s pulse is generated at the PWM output when the programmed timer has elapsed without getting any trigger for the trigger source.

## 12 Keypad controller

The keypad controller consists of:

- 4 dedicated key controllers that support up to 4 simultaneous dedicated key presses;
- a keyscan controller support a maximum of 8 x 8 key matrix with detection of three simultaneous key presses;
- 8 special function key controllers that support up to 8 simultaneous “special function” key presses.

Four of the column inputs can be configured as dedicated keys through the setting of Dkey0~3 bits of the KPC\_CTRL register.

The normal key matrix size can be configured through the setting of KPC\_ROW and KPC\_COL registers. The scanning of each individual row output and column input can be enabled or masked to support a key matrix of variable size from 1 x 1 to 8 x 8. It is allowed to have other 8 special function keys incorporated in the key matrix.

The operation of the keypad controller is enabled by the SCAN bit of KPC\_CTRL register. Every key activity detected will be de-bounced for a period set by the DB\_1~7 bits of KPC\_CTRL register before a key press or key release is confirmed and updated into the output FIFO. The key data, indicating the key coordinates and its status (up or down), is loaded into the FIFO at the end of a specified number of scanning cycles (set by SCAN\_COUNT0~3 bits of KPC\_CTRL\_MSB register). An interrupt will be generated when a new set of key data is loaded. The FIFO has a capacity for ten sets of key data. Each set of key data consists of 5 bytes of information when any of the four dedicated keys is enabled. It is reduced to 4 bytes when no dedicated key is involved. When the FIFO is full before its content is read, an overflow signal will be generated while the FIFO will continue to hold its content but forbid loading of new key data set.

**Figure 8. Keypad controller**

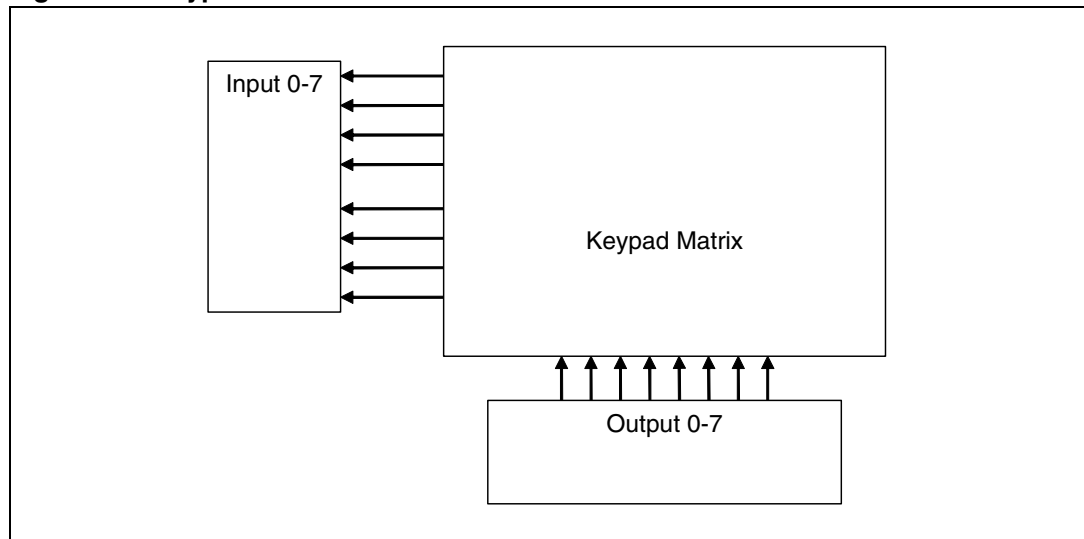

The keypad column inputs enabled by the KPC\_col register are normally 'high', with the corresponding input pins pulled up by resistors internally. After reset, all the keypad row outputs enabled by the KPC\_row register are driven 'low'. If a key is pressed, its corresponding column input will become 'low' after making contact with the 'low' voltage on its corresponding row output.

Once the keyscan controller senses a 'low' input on any of the column inputs, the scanning cycles will then start to determine the exact key that has been pressed. The eight row outputs will be driven 'low' one by one during each scanning cycle. While one row is driven 'low', all other rows are in tri-state and pulled up. If there is any column input sensed as 'low' when a row is driven 'low', the key scan controller will then decode the key coordinates (its corresponding row number and column number), save the key data into a de-bounce buffer if available, confirm if it is a valid key press after de-bouncing, and update the key data into output data FIFO if valid.

## 12.1 Keypad configurations

The keypad controller supports the following types of keys:

- Up to 8 input \* 8 output matrix keys
- Up to 8 special function keys
- Up to 4 dedicated keys

**Figure 9. Maximum configuration**

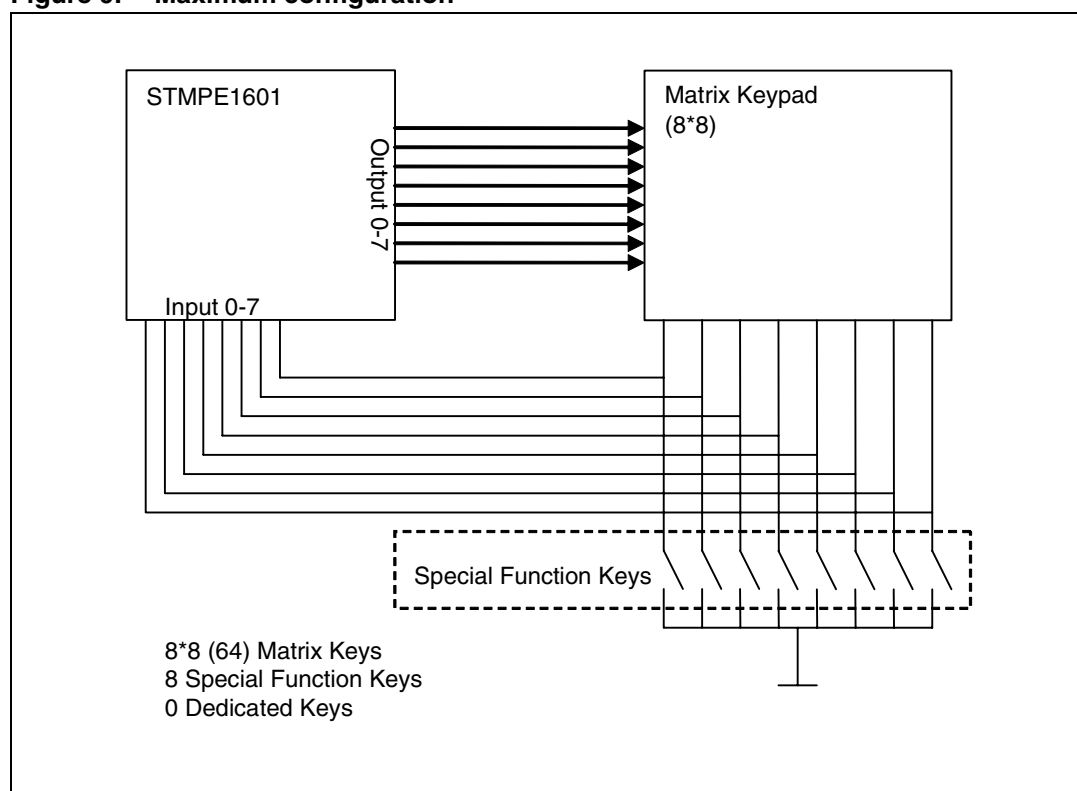
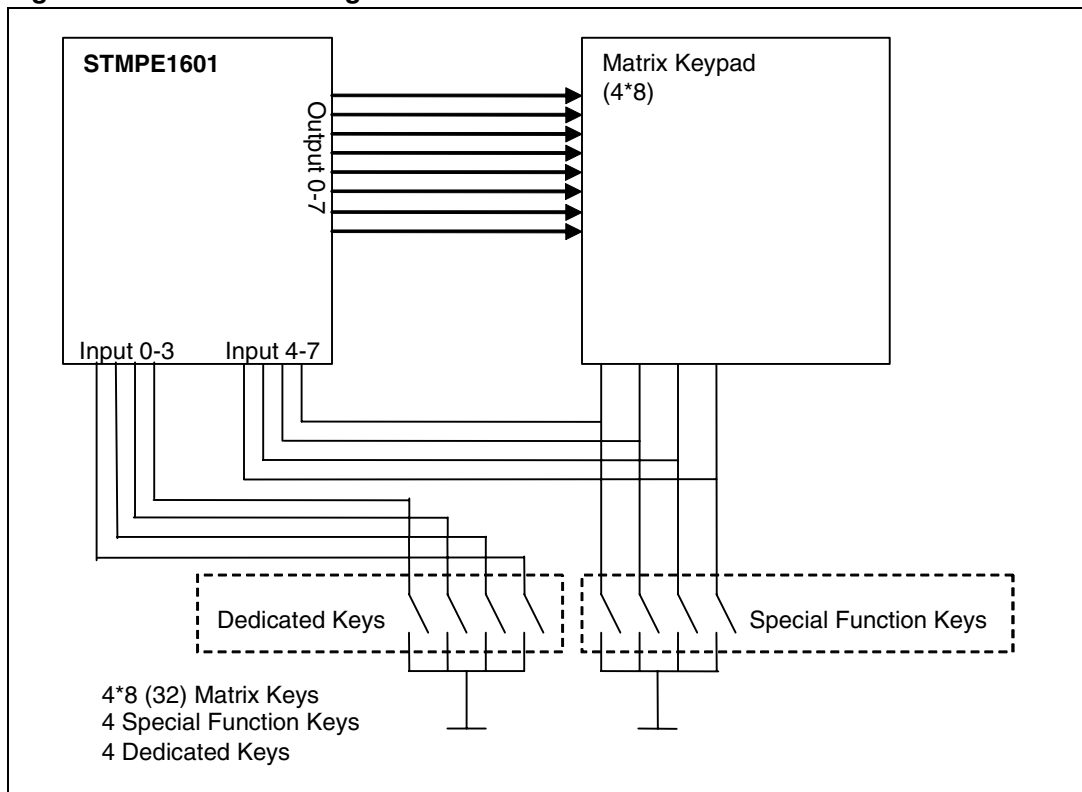

Figure 10. Maximum configuration



## 12.2 Keypad controller registers

**Table 24. Keypad controller registers**

Address	Register name	Description	Auto-increment (during sequential R/W)
0x60	KPC_COL	Keypad column scanning register	Yes
0x61	KPC_ROW_MSB	Keypad row scanning register	Yes
0x62	KPC_ROW_LSB		Yes
0x63	KPC_CTRL_MSB	Keypad control register	Yes
0x64	KPC_CTRL_LSB		Yes
0x65	KPC_COMBI_KEY_0	Keypad combination key mask 0	Yes
0x66	KPC_COMBI_KEY_1	Keypad combination key mask 1	Yes
0x67	KPC_COMBI_KEY_2	Keypad combination key mask 2	Yes
0x68	KPC_DATA_BYTE0	Keypad data register	Yes
0x69	KPC_DATA_BYTE1		Yes
0x6A	KPC_DATA_BYTE2		Yes
0x6B	KPC_DATA_BYTE3		Yes
0x6C	KPC_DATA_BYTE4		Yes

**KPC\_COL**

**Keypad controller column register**

7	6	5	4	3	2	1	0
Input Column 0 ~ 7							
RW	RW	RW	RW	RW	RW	RW	RW
0	0	0	0	0	0	0	0

**Address:** 0x60

**Type:** R/W

**Reset:** 0x00

**Description:** Keypad column scanning

- [7] **INPUT COLUMN:**  
1: turn on scanning of column 7  
0: turn off
- [6] **INPUT COLUMN:**  
1: turn on scanning of column 6  
0: turn off
- [5] **INPUT COLUMN:**  
1: turn on scanning of column 5  
0: turn off
- [4] **INPUT COLUMN:**  
1: turn on scanning of column 4  
0: turn off
- [3] **INPUT COLUMN:**  
1: turn on scanning of column 3  
0: turn off
- [2] **INPUT COLUMN:**  
1: turn on scanning of column 2  
0: turn off
- [1] **INPUT COLUMN:**  
1: turn on scanning of column 1  
0: turn off
- [0] **INPUT COLUMN:**  
1: turn on scanning of column 0  
0: turn off

**KPC\_ROW\_MSB**

**Keypad controller row MSB**

7	6	5	4	3	2	1	0
SCAN_PW1	SCAN_PW0	HIB_WK	-	RESERVED			
R/W	R/W	R/W	R	R	R	R	R
1	1	0	0	0	0	0	0

**Address:** 0x61

**Type:** R/W, R

**Reset:**

**Description:** Keypad row scanning register

[7:6] **SCAN\_PW[1:0]:**

Row output scanning pulse width setting:

00: 1x period of internal clock

01: 16x period of internal clock

10: 64x period of internal clock

11: 128x period of internal clock (default)

(This setting is only applicable during normal operation mode. The scanning pulse width is 1x period of 32 kHz clock during sleep mode.)

[5] **HIB\_WK:**

1: to enable the keypad wake-up from hibernate mode

0: to disable

[4:0] RESERVED

**KPC\_ROW\_LSB**

**Keypad controller row (LSB)**

7	6	5	4	3	2	1	0
OUTPUT ROW 0 ~ 7							
R/W	R/W	R/W	R/W	R/W	R/W	R/W	R/W
0	0	0	0	0	0	0	0

**Address:** 0x62

**Type:**

**Reset:** 0x00

**Description:** Keypad row scanning register.

[7:0] **OUTPUT ROW 0 ~ 7:**

'1' to turn on scanning of the corresponding row;

'0' to turn off



**KPC\_CTRL\_MSB**

**Keypad controller control (MSB)**

7	6	5	4	3	2	1	0
SCAN_COUNT_0 ~ 3				DKEYy_0 ~ 3			
RW	RW	RW	RW	RW	RW	RW	RW
0	0	0	0	0	0	0	0

**Address:** 0x63

**Type:** R/W

**Reset:** 0x00

**Description:** Keypad control register.

- [7:4] **SCAN\_COUNT\_0~ 3:**  
Number of key scanning cycles elapsed before a confirmed key data is updated into output data FIFO (0 ~ 15 cycles)
- [3] **DKEY\_3:**  
Set '1' to use input column 3 as dedicated key
- [2] **DKEY\_2:**  
Set '1' to use input column 2 as dedicated key
- [1] **DKEY\_1:**  
Set '1' to use input column 1 as dedicated key
- [0] **DKEY\_0:**  
Set '1' to use input column 0 as dedicated key

**KPC\_CTRL\_LSB**

**Keypad controller control (LSB)**

7	6	5	4	3	2	1	0
DB[6:0]							SCAN
R/W	R/W	R/W	R/W	R/W	R/W	R/W	R/W
0	0	0	0	0	0	0	0

**Address:** 0x64

**Type:** R/W

**Reset:** 0x00

**Description:** Keypad control register.

- [7:1] **DB\_6:0:**  
0-128 ms of de-bounce time
- [0] **SCAN:**  
1: to start scanning  
0: to stop

## 13 Data registers

The KPC\_DATA register contains five bytes of information. The first three bytes store the key coordinates and status of any three keys from the normal key matrix, while the fourth byte stores the status of special function keys and the fifth byte consists of the the status of dedicated keys.

### KPC\_DATA\_BYTE0

### Keypad data byte 0

7	6	5	4	3	2	1	0
UP/DOWN	R3	R2	R1	R0	C2	C1	C0
R	R	R	R	R	R	R	R
1	1	1	1	1	0	0	0

**Address:** 0x68

**Type:** R

**Reset:** 0xF8

**Description:** Keypad data register.

[7] **UP/DOWN:**

0: key-down

1: key-up

[6:3] **R[3:0]**

Row number of key 1 (valid range: 0-7)

0x1111: No Key

[2:0] **C[2:0]:**

Column number of key 1 (valid range: 0-7)

**KPC\_DATA\_BYTE1**

**Keypad data byte 1**

7	6	5	4	3	2	1	0
Up/Down	R3	R2	R1	R0	C2	C1	C0
R	R	R	R	R	R	R	R
1	1	1	1	1	0	0	0

**Address:** 0x69

**Type:** R

**Reset:** 0xF8

**Description:** Keypad data register.

[7] **UP/DOWN:**

0: key-down

1: key-up

[6:3] **R[3:0]**

Row number of key 2 (valid range: 0-7)

0x1111: No key

[2:0] **C[2:0]:**

Column number of key 2 (valid range: 0-7)

**KPC\_DATA\_BYTE2**

**Keypad data byte 2**

7	6	5	4	3	2	1	0
UP/DOWN	R3	R2	R1	R0	C2	C1	C0
R	R	R	R	R	R	R	R
1	1	1	1	1	0	0	0

**Address:** 0x6A

**Type:** R

**Reset:** 0xF8

**Description:** Keypad data register.

[7] **UP/DOWN:**

0: key-down

1: key-up

[6:3] **R[3:0]**

Row number of key 3 (valid range: 0 - 7)

0x1111: No key

[2:0] **C[2:0]:**

column number of key 3 (valid range: 0 -7)

**KPC\_DATA\_BYTE3**

**Keypad data byte 3**

7	6	5	4	3	2	1	0
SF7	SF6	SF5	SF4	SF3	SF2	SF1	SF0
R	R	R	R	R	R	R	R
1	1	1	1	1	1	1	1

**Address:** 0x6B  
**Type:** R  
**Reset:** 0xFF  
**Description:** Keypad data register.  
 [7:0] **SF[7:0]:**  
 0: key-down  
 1: key-up

**KPC\_DATA\_BYTE4**

**Keypad data byte 4**

	7	6	5	4	3	2	1	0
	RESERVED				Dedicated Key 0 ~ 3			
	R	R	R	R	R	R	R	R
	0	0	0	0	1	1	1	1

**Address:** 0x6C  
**Type:** R  
**Reset:** 0x0F  
**Description:** Keypad data register.

[7:4] **RESERVED**  
 [3:0] **Dedicated key [3:0]:**  
 0: key-down  
 1 key-up

# 14 Keypad combination key registers

The 3 keypad controller mask registers contains the key combination to be used to wake up the KPC and send an interrupt to the host system.

## KPC\_COMB\_KEY\_n

## Keypad combination [n=0-2]

7	6	5	4	3	2	1	0
ACTIVE	ACTIVE	R2	R1	R0	C2	C1	C0
R/W	R/W	R/W	R/W	R/W	R/W	R/W	R/W
1	1	1	1	1	0	0	0

**Address:** 0x65, 0x66, 0x67

**Type:** R/W

**Reset:** 0xF8

**Description:** Keypad combination key mask registers.

[7:6] **ACTIVE:**

00: key defined by bits 5:0 to be used for combination key wakeup

But [7:0] must be "F8" for No key from this register to be used for combination key wakeup

[5:3] **R[2:0]:**

Row number of key *n* (valid range: 0 -7)

[2:0] **C[2:0]:**

Column number of key *n* (valid range : 0-7)

## Resistance

The maximum resistance between keypad outputs and inputs, inclusive of switch resistance, protection circuit resistance and connection, must be less than 3.2 k $\Omega$

## Using the keypad controller

It is not necessary to explicitly enable the internal pull-up and direction by configuring the GPIO control registers. Once a GPIO is enabled for the keypad function, its internal pull-up and direction is controlled automatically.

The scanning of column inputs should then be enabled for those GPIO ports that are configured as keypad inputs by writing '1's to the corresponding bits in the KPC\_COL register. If any of the first four column inputs is to be used as dedicated key input, the corresponding bits in the KPC\_CTRL\_MSB register should be set to '1'. The bits in the KPC\_ROW\_MSB and KPC\_ROW\_LSB registers should also be set correctly to enable the row output scanning for the corresponding GPIO ports programmed as keypad outputs.

The scan count and de-bounce count should also be programmed into the keypad control registers before enabling the keypad controller operation. To enable the keypad controller operation, the EN\_KPC bit in the system control register must be set to '1' to provide the required clock signals. The keypad controller will then start its operation by setting the SCAN bit in the KPC\_CTRL\_LSB register to '1'.

The keypad controller operation can be disabled by setting the SCAN bit back to '0'. To further reduce the power consumption, the clock signals can be cut off from the keypad controller by setting the EN\_KPC bit to '0'.

As long as there is any un-read key-press in the keypad controller buffer, the KPC interrupt will always be asserted.

## Ghost key handling

The ghost key is an inherent in keypad matrix that is not equipped with a diode at each of the keys. While it is not possible to avoid ghost key occurrence, the STMPE1601 allows the detection of possible ghost keys by the capability of detecting 3 simultaneous key-presses in the key matrix.

The ghost key is only possible if 3 keys are pressed and held down together in a keypad matrix. If 3 keys are reported by the STMPE1601 keypad controller, it indicates a potential ghost key situation. The system may check for the possibility of a ghost key by analyzing the coordinates of the 3 keys. If the 3 keys form 3 corners of a rectangle, it could be a ghost key situation.

A ghost key may also occur in the "special function keys". The keypad controller does not attempt to avoid the occurrence of ghost keys. However, the system should be aware that if more than one special function key is reported, then there is a possibility of ghost keys.

### Key detection priority

A dedicated key is always detected, if this is enabled. When a special function key is detected, the matrix key scanning on the same input line is disabled.

Up to 3 matrix keys can be detected. Matrix keys that fall on activated special function keys are not counted.

As a result of these priority rules, a matrix key is ignored by the keypad controller when the special function key on the same input line is detected, even if the matrix key is being pressed down before the special function key. Hence, when a matrix is reported "key-down" and it is being held down while the corresponding special function is being pressed, a "no-key" status will be reported for the matrix key when the special function key is reported "key-down". If the matrix key is released while the special function key is still being held down, no "key-up" will be reported for the matrix key. On the other hand, if the matrix key is released after the special function key is reported "key-up", then a new "key-down" will be reported for the matrix key, followed by "key-up".

### Keypad wakeup from sleep and hibernate modes

The keypad controller is functional in sleep mode as long as it is enabled before entering the sleep mode. It will then wake the system up into operational mode if a valid key press is detected.

In the case of hibernate mode, the 'HIB\_WK' bit in 'KPC\_ROW\_msb' register must be set to '1' in order to enable the system wakeup by means of a valid key press. When this is enabled, an asynchronous detection of the keypad column input activity is turned on during the hibernate mode. If any key activity is detected, the system is expected to enter the sleep mode temporarily to allow a debouncing of key press to take place. If a valid key is detected, the system will then wake up into operational mode; otherwise, the device will go back into hibernate mode.

### Keypad controller combination-key interrupt

The keypad controller (KPC) can be programmed to wake up from sleep mode if a unique combination keys is detected. This combination keys of up to 3 keys is specified in the KPC combination set 0-2 registers. Note that the sequence of the key pressed is not relevant, as long as the 1-3 keys specified in the KPC\_COMB\_KEY registers are detected, the KPC will wake up and interrupt the host.

If any other keys (beside those specified in the KPC\_COMB\_KEY\_N registers) are pressed, it would be considered an invalid combination and no interrupt will be generated.

All the "active" keys must be pressed and held together, for the combi-key interrupt to be generated.

## 15 Miscellaneous features

### 15.1 Reset

The STMPE1601 is equipped with an internal POR circuit that holds the device in reset state, until the clock is steady and  $V_{CC}$  input is valid. The host system may choose to reset the STMPE1601 by asserting the RESET\_N pin.



## 16 Package mechanical data

In order to meet environmental requirements, ST offers these devices in different grades of ECOPACK<sup>®</sup> packages, depending on their level of environmental compliance. ECOPACK<sup>®</sup> specifications, grade definitions and product status are available at: [www.st.com](http://www.st.com). ECOPACK<sup>®</sup> is an ST trademark.

Figure 11. Package outline for TFBGA25

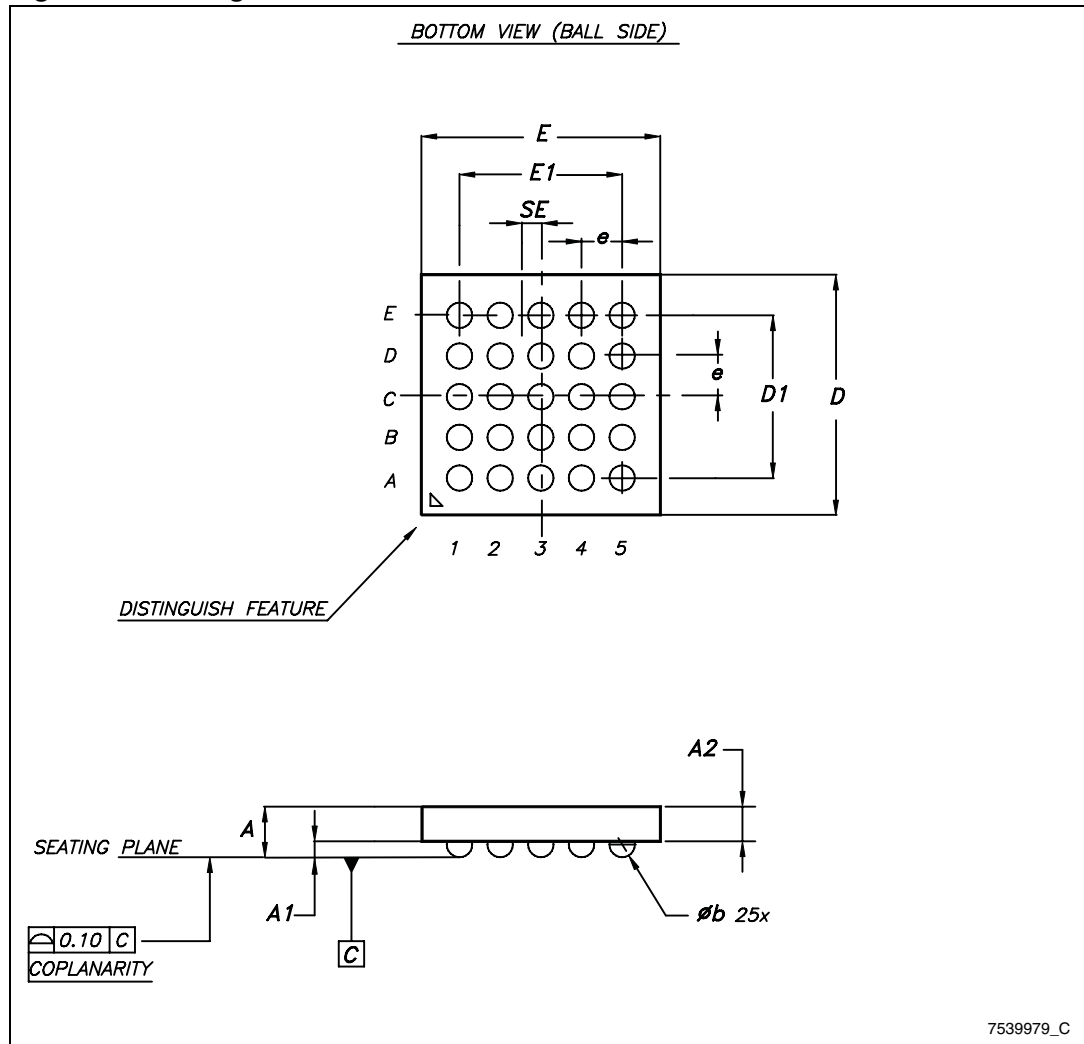

Table 25. Mechanical data for TFBGA25

Symbol	Millimeters		
	Min	Typ	Max
A	1.0	1.1	1.16
A1	–	–	0.25
A2	0.78	–	0.86
b	0.25	0.30	0.35
D	2.9	3.0	3.1
D1	–	2	–
E	2.9	3.0	3.1
E1	–	2	–
e	–	0.5	–
SE	–	0.25	–

Figure 12. Carrier tape information for TFBGA25

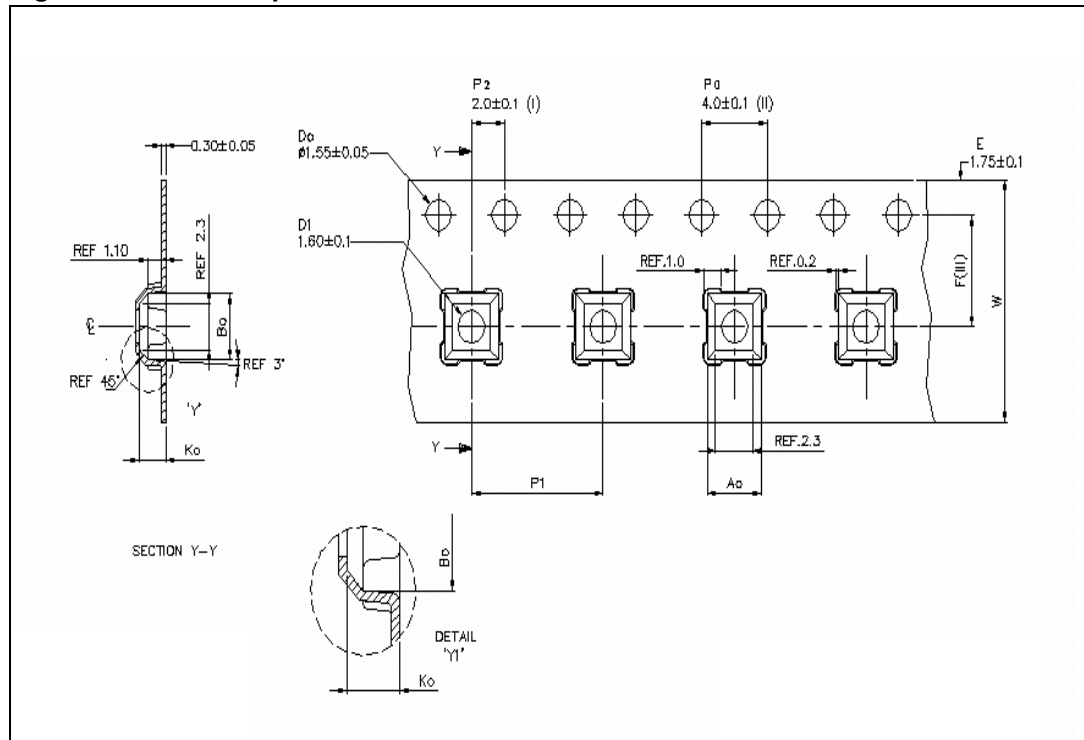

Table 26. Carrier tape mechanical data for TFBGA25

Symbol	Millimeters		
	Min	Typ	Max
Ao	3.2	3.3	3.4
Bo	3.2	3.3	3.4
Ko	1.5	1.6	1.7
F	5.4	5.5	5.6
P <sub>1</sub>	7.9	8.	8.1
W	11.70	12.00	12.30

Figure 13. Reel drawing for TFBGA25

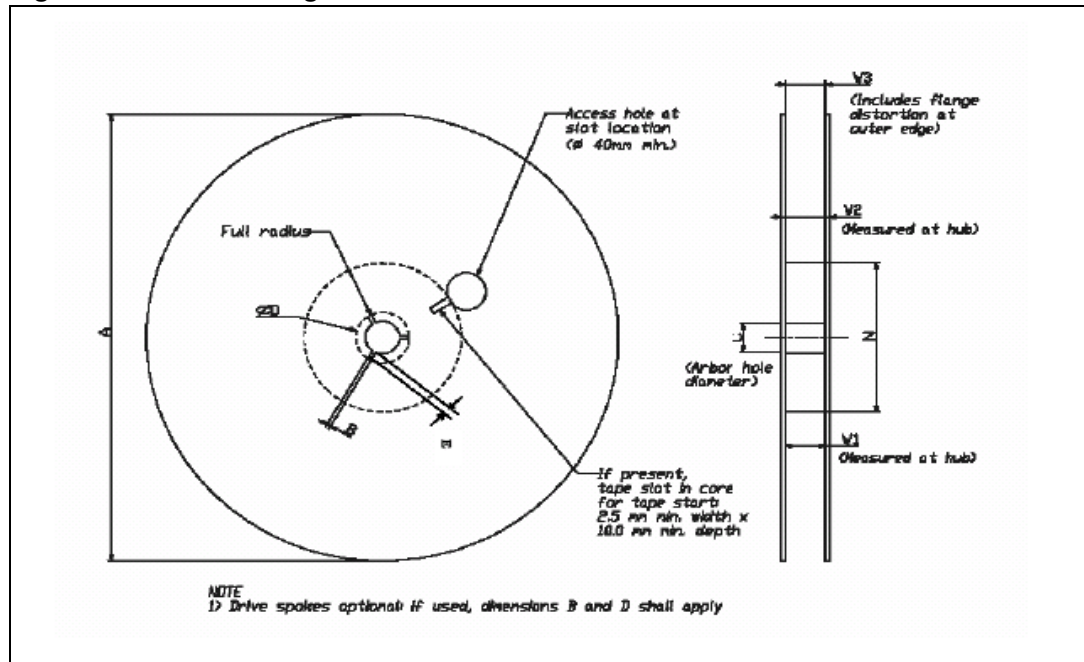

Table 27. Tape and reel dimensions for TFBGA25 (12 mm width)

Symbol	Millimeters		
	Min	Typ	Max
N	173	178	183
W1	-	12.4	12.6
W2	-	-	18.4
C	12.75	13	13.25

## 17 Revision history

**Table 28. Document revision history**

Date	Revision	Changes
10-Jan-2008	1	Initial release.
15-Feb-2008	2	Modified <a href="#">Figure 1 on page 4</a> , added info on register <a href="#">Description: on page 41</a> and <a href="#">Section 6.1: Minimizing current drain on I2C address lines on page 13</a> , updated <a href="#">Table 7: DC electrical characteristics on page 9</a> , minor text changes.
14-Mar-2008	3	Updated <a href="#">Table 7: DC electrical characteristics on page 9</a>
02-June-2008	4	Document status promoted from preliminary data to datasheet. Modified: <a href="#">Figure 1 on page 4</a> , $R_{up}$ values in <a href="#">Table 10</a> , <a href="#">Channel function enabling</a> and <a href="#">PWM trigger register [n = 0 - 3]</a> registers. Updated: <a href="#">Section 6: I2C interface</a> , <a href="#">Section 7: System controller</a> , <a href="#">Section 9: Interrupt system</a> , <a href="#">Section 10: GPIO controller</a> , <a href="#">Section 11: Basic PWM controller</a> , <a href="#">Section 12: Keypad controller</a>
10-Nov-2008	5	Content reworked to improve readability. Updated: keypad controller data registers description, package, carrier tape and reel information.
01-Feb-2010	6	Modified: renamed $\mu$ TFBGA25 to TFBGA25, <a href="#">Figure 1 on page 4</a> , <a href="#">Table 19: GPIO controller (Base address = 0 x 80) on page 31</a> , Updated: <a href="#">Table 2: Pin assignment on page 5</a> , <a href="#">Table 11: Register map summary table on page 11</a> , <a href="#">Section 7: System controller</a>

**Please Read Carefully:**

Information in this document is provided solely in connection with ST products. STMicroelectronics NV and its subsidiaries ("ST") reserve the right to make changes, corrections, modifications or improvements, to this document, and the products and services described herein at any time, without notice.

All ST products are sold pursuant to ST's terms and conditions of sale.

Purchasers are solely responsible for the choice, selection and use of the ST products and services described herein, and ST assumes no liability whatsoever relating to the choice, selection or use of the ST products and services described herein.

No license, express or implied, by estoppel or otherwise, to any intellectual property rights is granted under this document. If any part of this document refers to any third party products or services it shall not be deemed a license grant by ST for the use of such third party products or services, or any intellectual property contained therein or considered as a warranty covering the use in any manner whatsoever of such third party products or services or any intellectual property contained therein.

**UNLESS OTHERWISE SET FORTH IN ST'S TERMS AND CONDITIONS OF SALE ST DISCLAIMS ANY EXPRESS OR IMPLIED WARRANTY WITH RESPECT TO THE USE AND/OR SALE OF ST PRODUCTS INCLUDING WITHOUT LIMITATION IMPLIED WARRANTIES OF MERCHANTABILITY, FITNESS FOR A PARTICULAR PURPOSE (AND THEIR EQUIVALENTS UNDER THE LAWS OF ANY JURISDICTION), OR INFRINGEMENT OF ANY PATENT, COPYRIGHT OR OTHER INTELLECTUAL PROPERTY RIGHT.**

**UNLESS EXPRESSLY APPROVED IN WRITING BY AN AUTHORIZED ST REPRESENTATIVE, ST PRODUCTS ARE NOT RECOMMENDED, AUTHORIZED OR WARRANTED FOR USE IN MILITARY, AIR CRAFT, SPACE, LIFE SAVING, OR LIFE SUSTAINING APPLICATIONS, NOR IN PRODUCTS OR SYSTEMS WHERE FAILURE OR MALFUNCTION MAY RESULT IN PERSONAL INJURY, DEATH, OR SEVERE PROPERTY OR ENVIRONMENTAL DAMAGE. ST PRODUCTS WHICH ARE NOT SPECIFIED AS "AUTOMOTIVE GRADE" MAY ONLY BE USED IN AUTOMOTIVE APPLICATIONS AT USER'S OWN RISK.**

Resale of ST products with provisions different from the statements and/or technical features set forth in this document shall immediately void any warranty granted by ST for the ST product or service described herein and shall not create or extend in any manner whatsoever, any liability of ST.

ST and the ST logo are trademarks or registered trademarks of ST in various countries.

Information in this document supersedes and replaces all information previously supplied.

The ST logo is a registered trademark of STMicroelectronics. All other names are the property of their respective owners.

© 2010 STMicroelectronics - All rights reserved

STMicroelectronics group of companies

Australia - Belgium - Brazil - Canada - China - Czech Republic - Finland - France - Germany - Hong Kong - India - Israel - Italy - Japan - Malaysia - Malta - Morocco - Philippines - Singapore - Spain - Sweden - Switzerland - United Kingdom - United States of America

[www.st.com](http://www.st.com)