

LEAD-FREE P/N	CABLES	∅d1	∅d2	∅d3	∅d4	d5	d6	Remarks
70297-001LF	RG 178B/U, RG196A/U TZC_50126	1.10	1.70	2.20	3.20	7.8	21.00	
70297-002LF	RG188A/U, RG174A/U, RG316/U	1.70	2.50	2.90	3.60	9.0	22.20	
70297-004LF	TZC_75106 (GORE CABLE) 75ohm	1.30	2.00	2.50	3.20	7.8	21.00	see note 2
70297-005LF	RG 179 75ohm	1.70	2.50	2.90	3.60	9.0	22.20	see note 2
70297-006LF	FILOTEX CABLE ALCATEL	1.30	2.00	2.50	3.20	7.8	21.00	see note 2

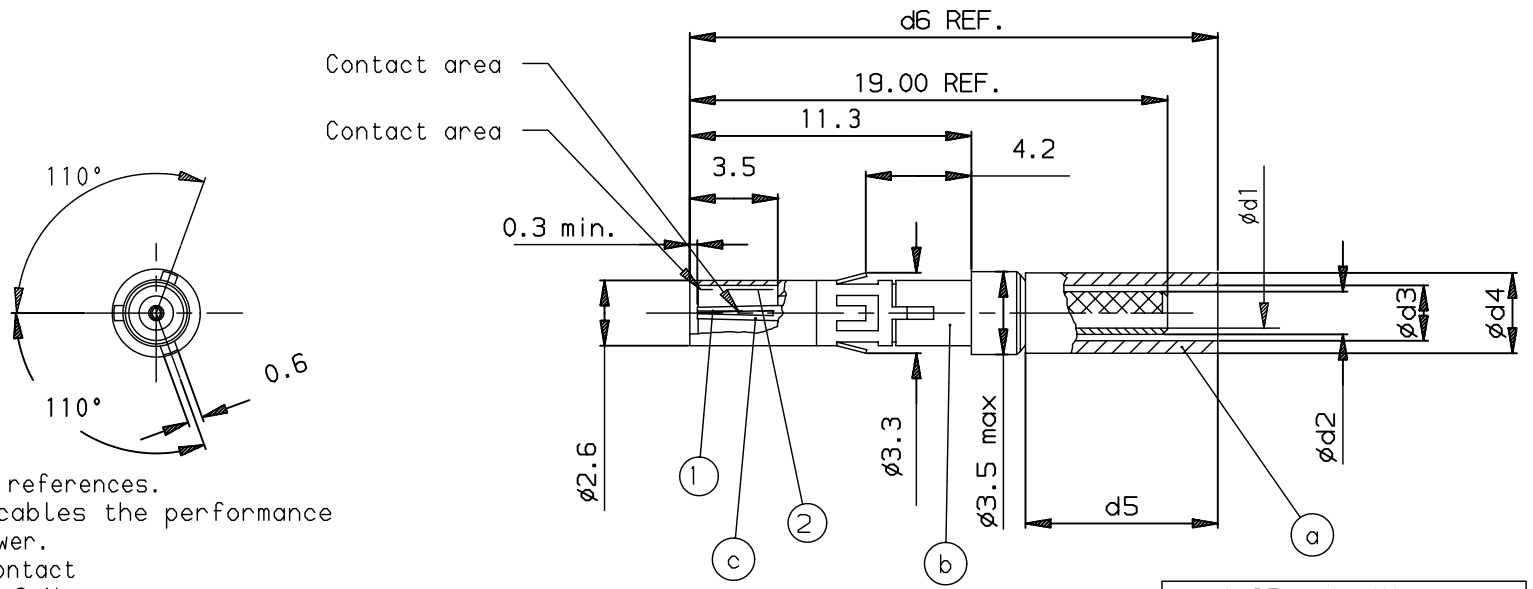

- NOTES:
- All dimensions shown are references.
 - When used with 75 ohm cables the performance of the contact will be lower.
 - Pull out for of center contact must be 0.1 N min. / 0.8 N max.
 - This product will be packed in a small plastic bag containing three lose parts, as follows.
 - Crimp Ferrule
 - Outer Contact
 - Inner Contact
 - Assemble product with tool HT430, use inserts EPL 193460 or EPL 193428.
 - THIS PRODUCT WITH "LF" SUFFIX MEETS EUROPEAN UNION DIRECTIVES AND OTHER COUNTRY REGULATIONS AS DESCRIBED IN GS -22-008.
 - THE PRODUCT IS NOT INTENDED TO BE EXPOSED TO A MANUFACTURING SOLDER PROCESS.
 - PACKAGING SPEC: SEE GS-14-920

1.27µm Au Min.
Positions 1&2
Plating on contact area

www.fciconnect.com		surface ISO 1302 ✓	tolerance std ISO 406 ISO 1101	projection mm
TOLERANCES UNLESS OTHERWISE SPECIFIED				
ANGULAR	LINEAR	0.X	±0.1	size A3
0.X' ±2'	0.XXX	±0.1	Scale 5	ECN LS07-0249
Dr	GOISNARD	2006/03/04	Product family	METRAL
Eng	GOISNARD	2006/03/04	Spec ref	-
Chr	LEGARE	2006/03/04	Rev.	L
Appr	LEGARE	2006/03/04	dwg no	70297
title CRIMP TO CABLE RECEPTACLE MINI COAX			catalog no	CUSTOMER
sheet 1 of 1			sheet 1 of 1	

rev	ecn no	dr	date
J	LS06-0022	LGO	2006/03/04
K	LS07-0214	LGO	2007/08/20
L	LS07-0249	LGO	2007/10/02
-	-	-	-
-	-	-	-
-	-	-	-
-	-	-	-

Copyright FCI. FCI