

# Development Board EPC9147C Quick Start Guide

*Motor Drive Controller Interface Board –  
STMicroelectronics STM32 Nucleo*

Revision 2.2

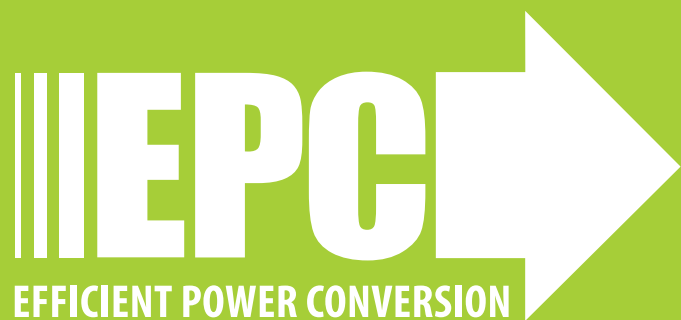

**DESCRIPTION**

The EPC9147C board is an interface board that accepts the STMicroelectronics STM32 NUCLEO-G431RB motor drive development board, that is fitted with the STM32G431RBT6 ARM Digital Controller, and interfaces to a 3-phase eGaN® FET/IC motor drive inverter board. This interface board allows users to utilize the existing STMicroelectronics Integrated Development Environment resources to program the controller board that controls a motor powered by an eGaN FET/IC 3-phase inverter using sensor-less field oriented control with space vector pulse width modulation.

Figure 1 shows an overview of the EPC9147C board detailing connections and various human interfaces that measures 120 mm x 71 mm (L x W).

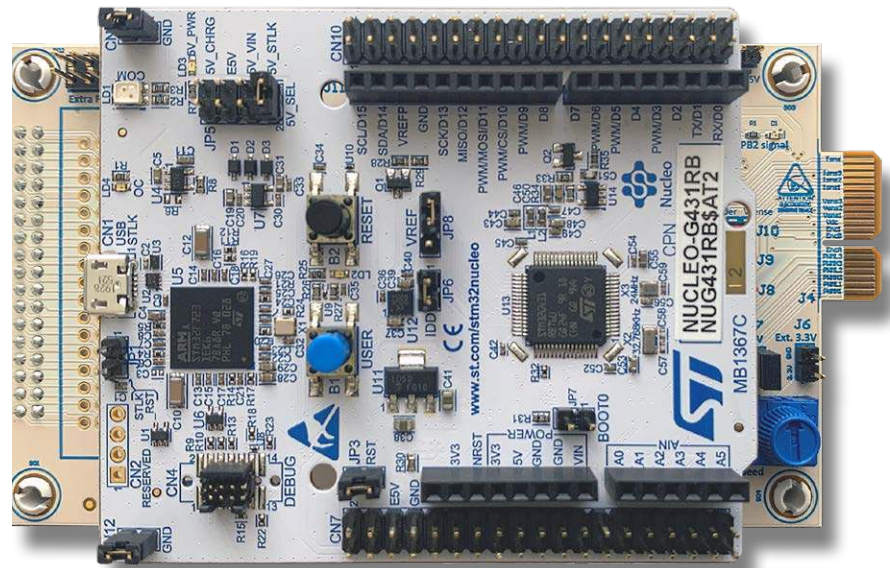

EPC9147C development board

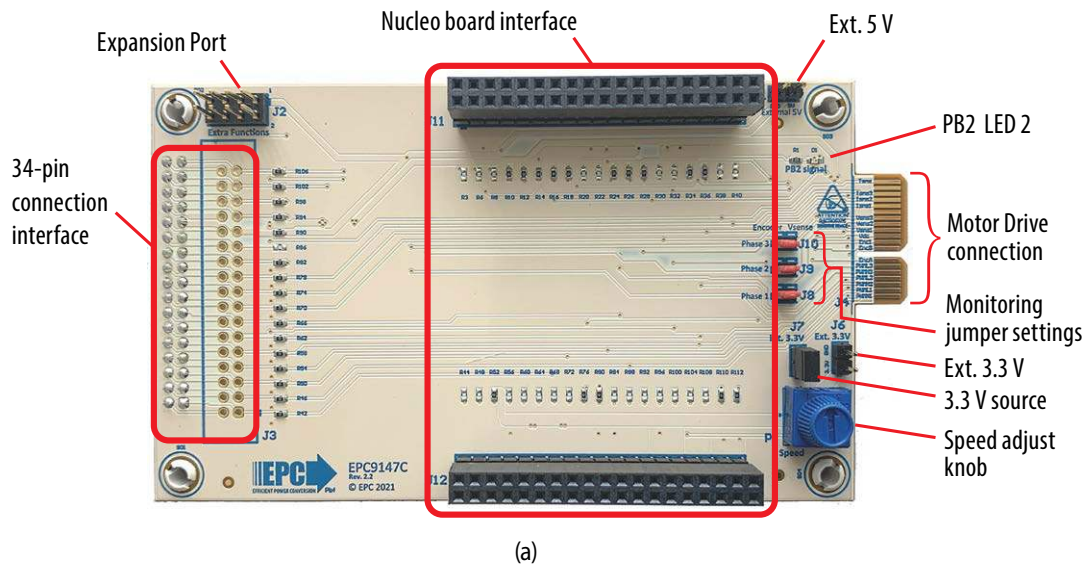

(a)

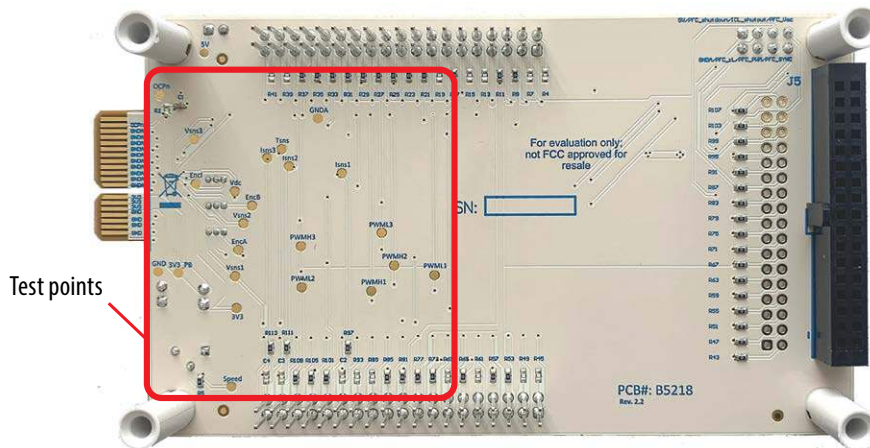

(b)

Figure 1: Overview of the EPC9147C board

The EPC9147C includes a standard STMicroelectronics STM32 NUCLEO-G431RB motor drive development board compatible connector (J11 & J12) that interfaces the PWM, analog feedback signal, errors states and 3.3 V power to the motor drive inverter board as shown in figure 2.

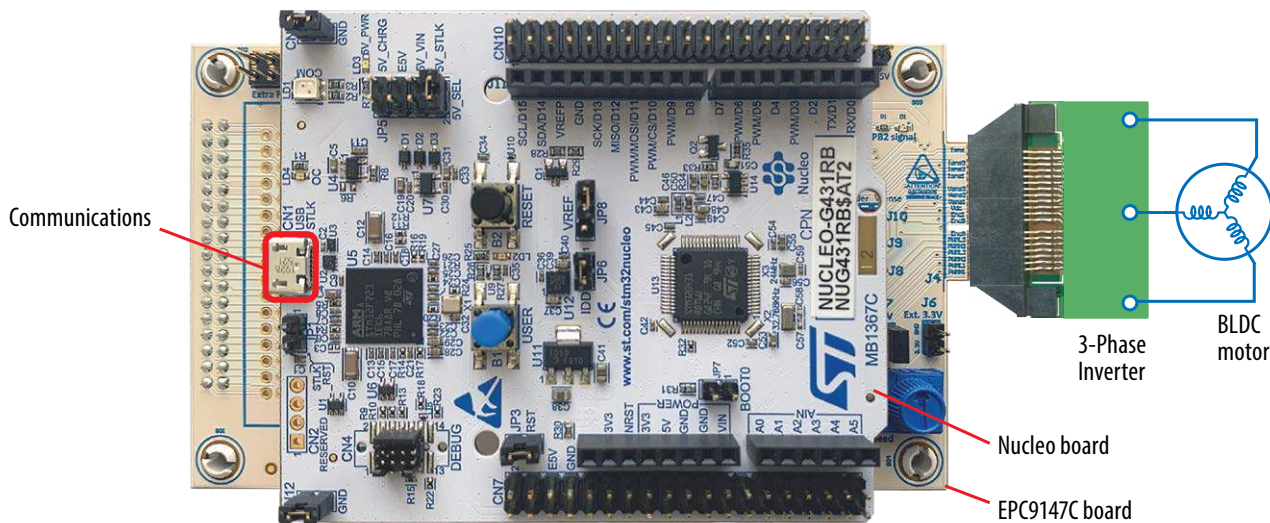

Figure 2: Application overview of the EPC9147C control interface board

**HUMAN INTERFACE CONTROLS AND INDICATORS**

The EPC9147C has a human interface controls and indicators as shown in figure 1.

To operate the motor the following controls are available:

- **Black** button on ST Nucleo board – press this button once after the power supply is set to prepare for motor run.
- **Blue** button on ST Nucleo board – press this button once to start the motor and press it again to stop the motor.
- Speed potentiometer on EPC9147C – This knob can be used to change the motor speed. By default, the potentiometer is not interfaced in original ST firmware, so it is up to the customer to modify the ST firmware to interface the potentiometer to use it as target speed setting analog interface.

There are LED indicators that provide information on the status of the controller:

**On Nucleo board:**

- Power LED (**green**) – The Nucleo board has power. Power is provided by the motor drive inverter, through the EPC9147C board.
- Status LED (**red**) – when it is flashing, the Nucleo board is ready for operation. After power up, press the black button at least once. The blue button is used for starting and stopping the motor.

**On EPC9147C board**

- PB2 signal status (**red**). This LED is not used by the official ST firmware. The user may re-program and customize the Nucleo board firmware and provide driving for this LED.

**Warning: The human interface controls and knob, as well as the entire EPC9147C, and the ST Nucleo board are not isolated. The EPC9147C is referenced to Power Ground and extreme caution must be observed when operating the board at high voltage.**

**Test Points**

Several test-points are available for measurement of various analog, error and PWM signals. Analog signals include voltage and current readings, input DC voltage to the drive, and current sense amplifier voltage reference. The operator is encouraged to read the motor drive inverter drive QSG carefully to determine the correct scaling factors. The locations of the test points are shown in figure 1(b).

**Monitoring Jumper Settings**

The EPC9147C is provided with a set of jumpers that can be used to change the monitoring connections. Table 1 provides a detailed list of the settings mapping and figure 3 shows this graphically.

**Table 1: Monitoring jumper settings mapping**

Jumper	Phase	Position 1-2 (default)	Position 2-3
J8	1	Shaft Encoder A	Motor Phase Voltage 1
J9	2	Shaft Encoder B	Motor Phase Voltage 2
J10	3	Shaft Encoder Index	Motor Phase Voltage 3

Any combination of valid position settings may be selected.

**Internal/External 3.3 V Power Jumper Setting**

The EPC9147C is provided with a jumper (J7) that, when it is mounted (by default), allows the 3.3 V power supply to be fed by the Power Board. If Jumper J7 is not mounted, the EPC9147C 3.3 V (and the ST Nucleo 3.3V) power must be supplied by an external 3.3 V power supply connected to the connector J6.

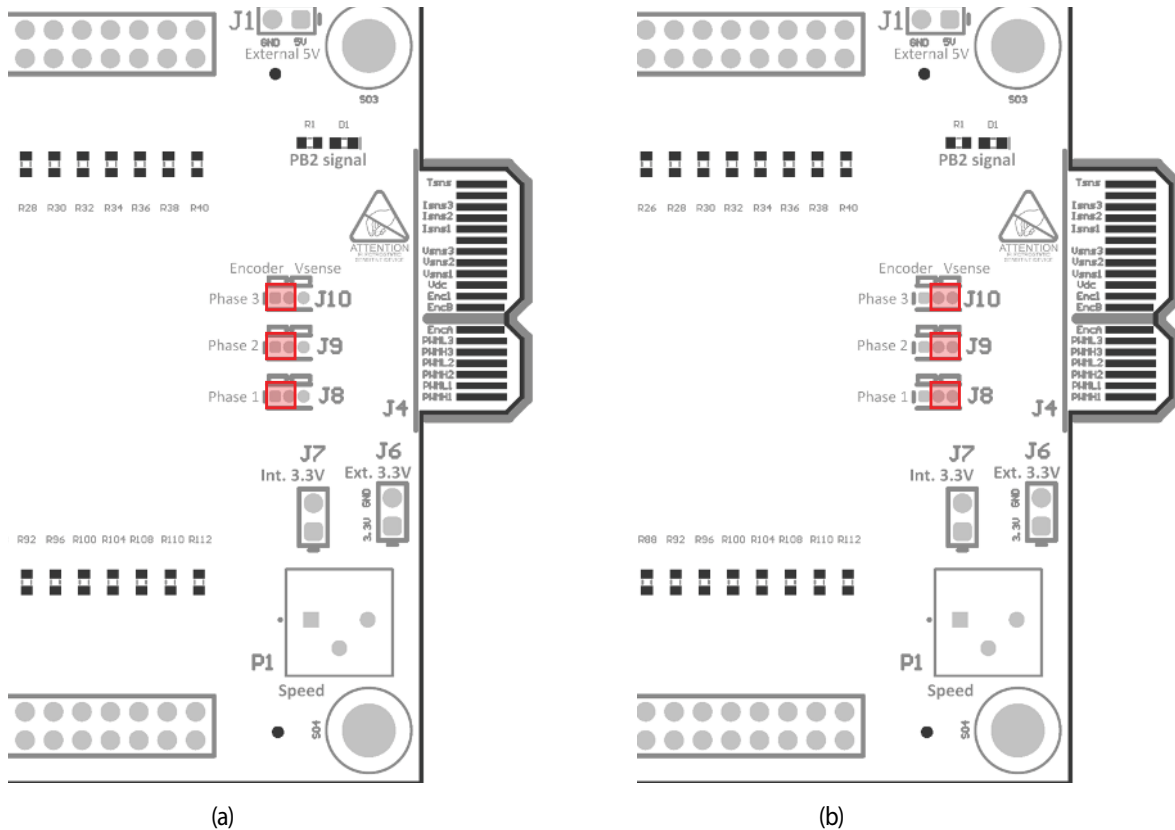

Figure 3: Monitoring jumper settings (a) shaft encoder (default), (b) phases voltage

### Compatible Motor Drive Inverters

A list of motor drive inverter power boards compatible to the EPC9147C is given in table 2.

**Table 2: Compatible eGaN FET/IC motor driver inverters to the EPC9147C**

Motor Drive Inverter Board Number	Basic Specifications	Web Link
EPC9146 Rev. 2.1	400 W, 3-phase BLDC Inverter using EPC2152	<a href="#">EPC9146 – 400 W Motor drive demo board</a>
EPC9145 Rev. 1.1	1000 W, 3-phase BLDC Inverter using EPC2206	<a href="#">EPC9145 – 1000 W Motor drive demo board</a>

### EPC9147C Electrical Specifications

**Table 3: Electrical Specifications (T<sub>A</sub> = 25°C) EPC9147C**

Symbol	Parameter	Conditions	Min	Nominal	Max	Units
V <sub>3.3EXT</sub>	External 3.3 V Operating voltage	J7 is not mounted	3.1	3.3	3.5	V
V <sub>5VEXT</sub>	External 5 V straight to ST board connector		4.9	5.0	5.1	V

### CONNECTION DETAILS

#### Inverter

A 40 pin connector is used to interface power, PWM signals and analog feedback signals between the interface board and the motor drive inverter. Table 4 gives the map (J2) for each signal

**Table 4: Motor interface connection (J2) pin allocation map**

Pin #	Pin Name		Pin #
2	PWMH1	GND	1
4	PWML1	GND	3
6	PWMH2	GND	5
8	PWML2	GND	7
10	PWMH3	3V3	9
12	PWML3	3V3	11
14	EncA	3V3	13
Index			
18	EncB	GND	17
20	EncI	GND	19
22	Vin	GND	21
24	V1	GND	23
26	V2	GND	25
28	V3	GND	27
30	Iin	GND	29
32	I1	GND	31
34	I2	GND	33
36	I3	GND	35
38	EN/Pgood	LEDerr	37
40	Tsns	LEDact	39

### PROGRAMMING

The ST Nucleo board that is connected to the EPC9147C board provides a full programmer and debugger onboard. The user can program the ST Nucleo board by using a USB cable connected to connector CN1 to the ST Nucleo board and by using official ST integrated development environment.

More details on the ST environment can be found at this page: [https://www.st.com/content/st\\_com/en/ecosystems/stm32-motor-control-ecosystem.html](https://www.st.com/content/st_com/en/ecosystems/stm32-motor-control-ecosystem.html)

The flow, as described by ST, can be depicted in Figure 4.

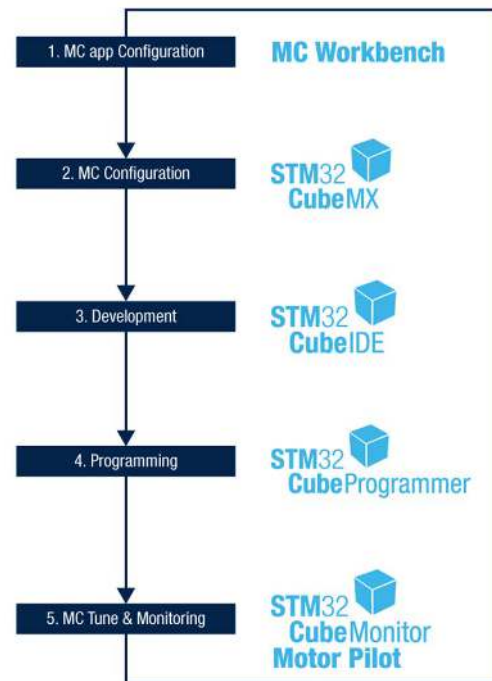

Figure 4 - ST motor control development programs

## PROGRAMMING WITH .elf FILE

The ST Nucleo board comes with an onboard programmer debugger. Connect the CN1 connector to a USB port of your computer and use the STM32 CubeProgrammer software. The CN1 connector requires a Micro B USB male cable. The STM32CubeProgrammer software can be downloaded from ST's website, after registration, at this link: <https://www.st.com/en/development-tools/stm32cubeprog.html>

Verify that the jumpers CN11 and CN12 in ST Nucleo board are mounted and that the selector on the 5V\_SEL is set on 5V\_STLK position. Start the STM32CubeProgrammer, click on **Connect** button by making sure that the ST-LINK option is chosen.

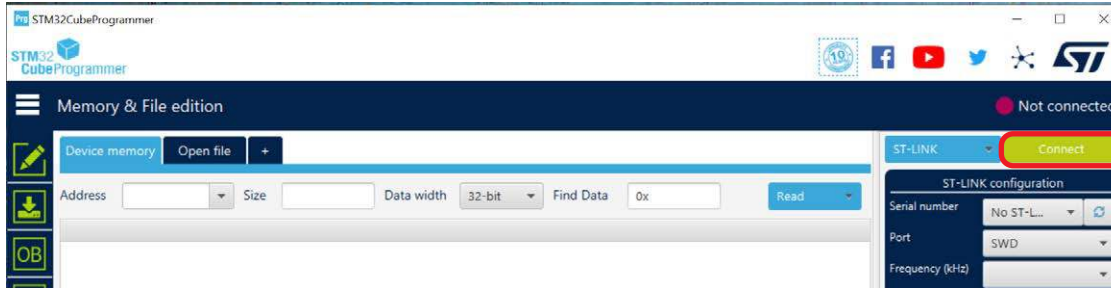

Figure 5: STM32CubeProgrammer

Once connected, click on the **Open File** tab and choose the proper .elf file to be programmed on the board. The original demo .elf file can be downloaded from [EPC website on the EPC9147C web page](#).

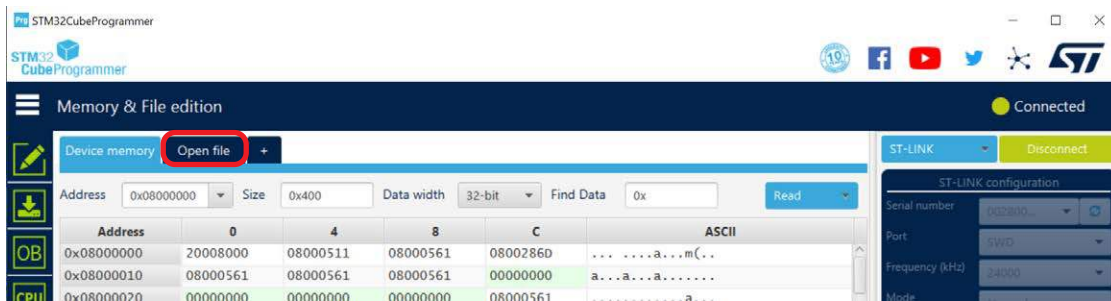

Figure 6: Open file tab

Click on the **filename** tab to bring it in front, so that it is fully visible. **Right-click** on the **filename** tab and choose the **Download** option. This will program the ST Nucleo flash memory. Once programming is done, it is possible to verify the Flash memory content if needed.

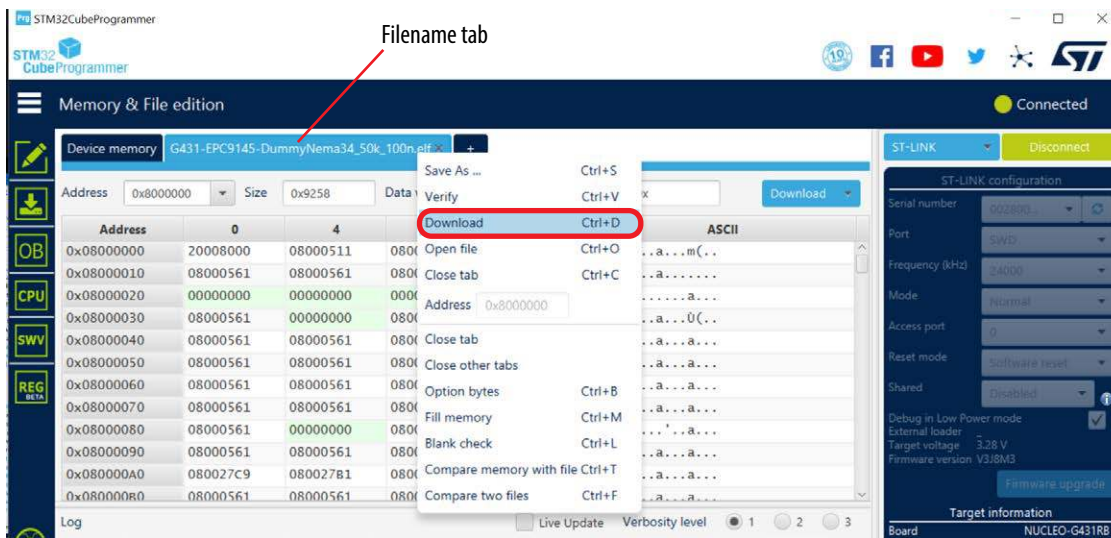

Figure 7: Open .elf file and download it to the flash memory

## EXTRA FUNCTION PORT

The EPC9147C is provided with an extra function port (J2) that can be used to expand functionality to the board. Table 6 provides the pin allocation map for the expansion port. The usage of the expansion port depends on official ST firmware. In the demo provided by EPC, these functions are not used.

**Table 6: Extra Function port (J2) pin allocation map**

Pin #	Connector
1	5 V
2	GND
3	PFC shutdown
4	PFC iL
5	ICL shutout
6	PFC PWM
7	PFC Vac
8	PFC Synce

## QUICK START PROCEDURE

Please check EPC's EPC9147C product page for updates on compatible eGaN FET/IC inverters with reference settings for specific motors:

<https://epc-co.com/epc/Products/DemoBoards/EPC9147c.aspx>

The demo program is set to drive a specific motor: Teknic M-3411P-LN-08D. If a different motor needs to be used, please follow these steps:

1. Verify that the ST Nucleo G431RB is properly mounted on the EPC9147C as shown in Figure 2.
2. Verify that on ST Nucleo board, CN11, CN12, JP6, and JP3 jumpers are mounted. JP8 **must** be in position 2-3, 5V\_SEL **must** be in 5V\_STLK position, and JP1 and JP7 are not mounted.
3. Connect the motor Teknic M-3411P-LN-08D to the power board. Only the three phase wires of the motor are needed, because the firmware is sensor-less.
4. Connect 48 V 3.0 A power supply to the power board connected to the EPC9147C.
5. Power up the 48 V power supply.
6. Press the **black** button once.
7. Press the **blue** button once. Motor start spinning at a fixed speed.
8. Press the **blue** button once again. Motor Stops.

**Warning: The human interface controls and knob, as well as the entire EPC9147C, and the ST Nucleo board are not isolated. The EPC9147C is referenced to Power Ground and extreme caution must be observed when operating the board at high voltage.**

## MOTOR COMMISSIONING PROCEDURE

To commission a new motor, the user **must** install the entire development suite from ST website after registration.

Download and install the following programs:

### ST Motor Control Workbench:

[https://www.st.com/content/st\\_com/en/products/embedded-software/mcu-mpu-embedded-software/stm32-embedded-software/stm32cube-expansion-packages/x-cube-mcsdk.html](https://www.st.com/content/st_com/en/products/embedded-software/mcu-mpu-embedded-software/stm32-embedded-software/stm32cube-expansion-packages/x-cube-mcsdk.html)

### STM32CubeMX

<https://www.st.com/en/development-tools/stm32cubemx.html>

### STM32CubeIDE

<https://www.st.com/en/development-tools/stm32cubeide.html>

For your reference, the page about the ST Nucleo G431RB is at this link:

<https://www.st.com/en/evaluation-tools/nucleo-g431rb.html#tools-software>

Once the software is properly installed, the user **must** follow this procedure:

1. Use the Motor Control Workbench with specific EPC project relevant to the specific EPC power board being used
2. Modify the motor parameters to adapt the system to the desired motor
3. Generate the code
4. Use STM32CubeIDE to compile, link, and flash the generated .elf file to the ST Nucleo board

### ST MOTOR CONTROL WORKBENCH

Download from EPC power board web page the proper .zip archive that contains the ST Motor Control Workbench project. Unzip the archive by placing the .stmcx file and the contained directory in a folder in your computer. E.g., for EPC9145 power board, the project file name is **G431-EPC9145-DummyNema34\_50k\_100n.zip**, and it contains a file **G431-EPC9145-DummyNema34\_50k\_100n.stmcx** and a directory named **G431-EPC9145-DummyNema34\_50k\_100n**. Save these in a specific location folder in your computer, then start the ST Motor Control Workbench program. Click on **Load Project** button (Figure 8) and choose the **G431-EPC9145-DummyNema34\_50k\_100n.stmcx** file. The architecture will be then shown in the program as in Figure 9.



Figure 8: ST Motor Control Workbench Load Project button

Double click on the **motor symbol**.

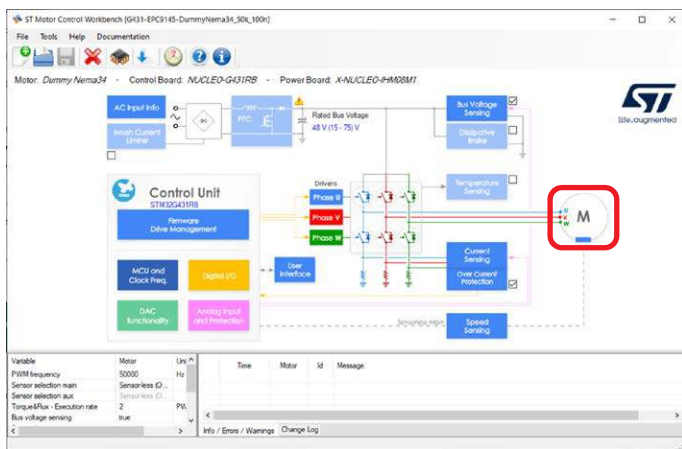

Figure 9: ST Motor Control Workbench

On the **Motor** tab, fill in the Electrical parameters and click the **Done** button:

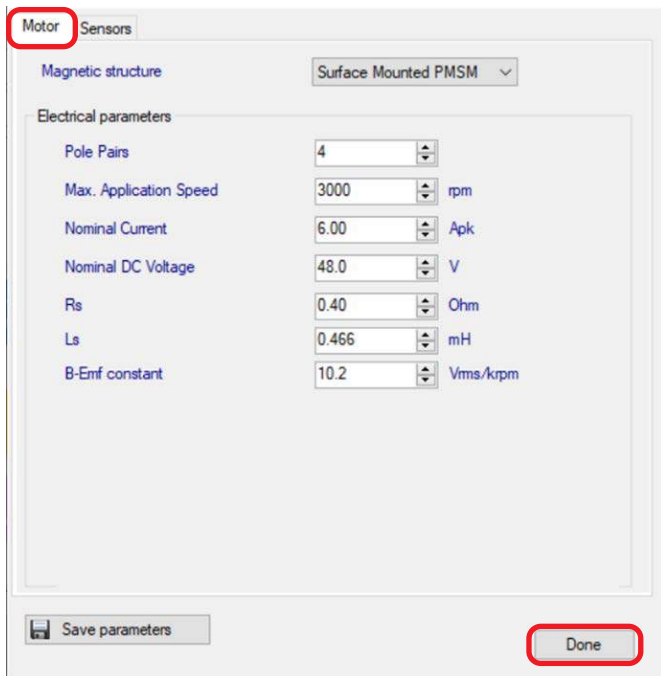

Figure 10: Motor Parameters

Next, click on the **Generation arrow** button:

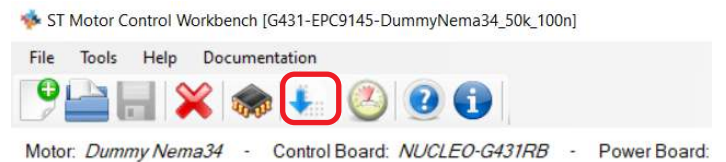

Figure 11: ST Motor Control Workbench Generate Code button



Project generation dialog box will appear. Verify it matches Figure 12's settings and then click **Generate**.

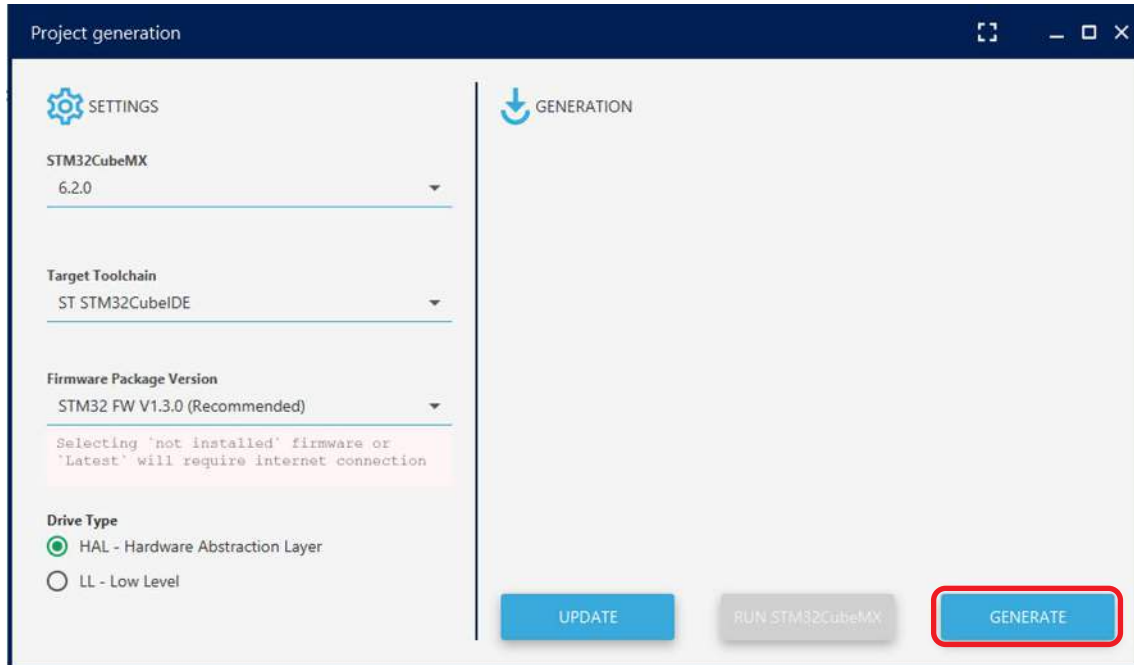

Figure 12: STM32CubeMX Code Generation dialog box

Once the Generation is complete, click **Open Folder** button and then click the **Close** button.

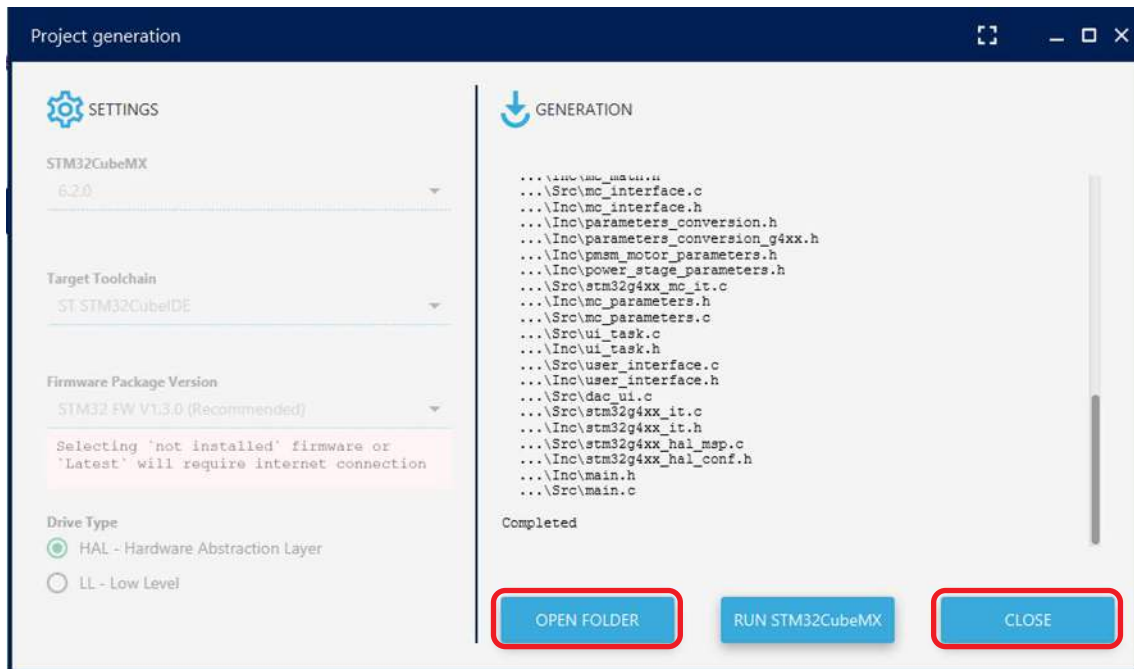

Figure 13: STM32CubeMX Code successfully generated

In the explorer window where the generated code folder is shown, as in Figure 14, open the folder named **STM32CubeIDE**.

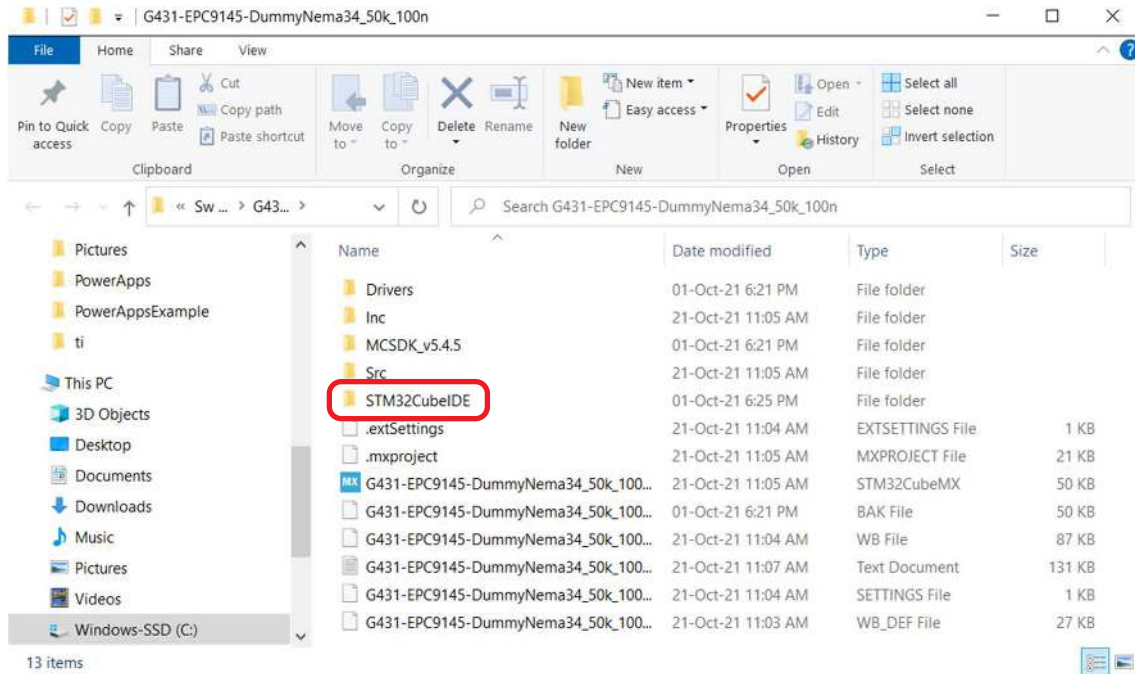

Figure 14: Generated code folder

Inside the STM32CubeIDE folder, double click the **.project** file.

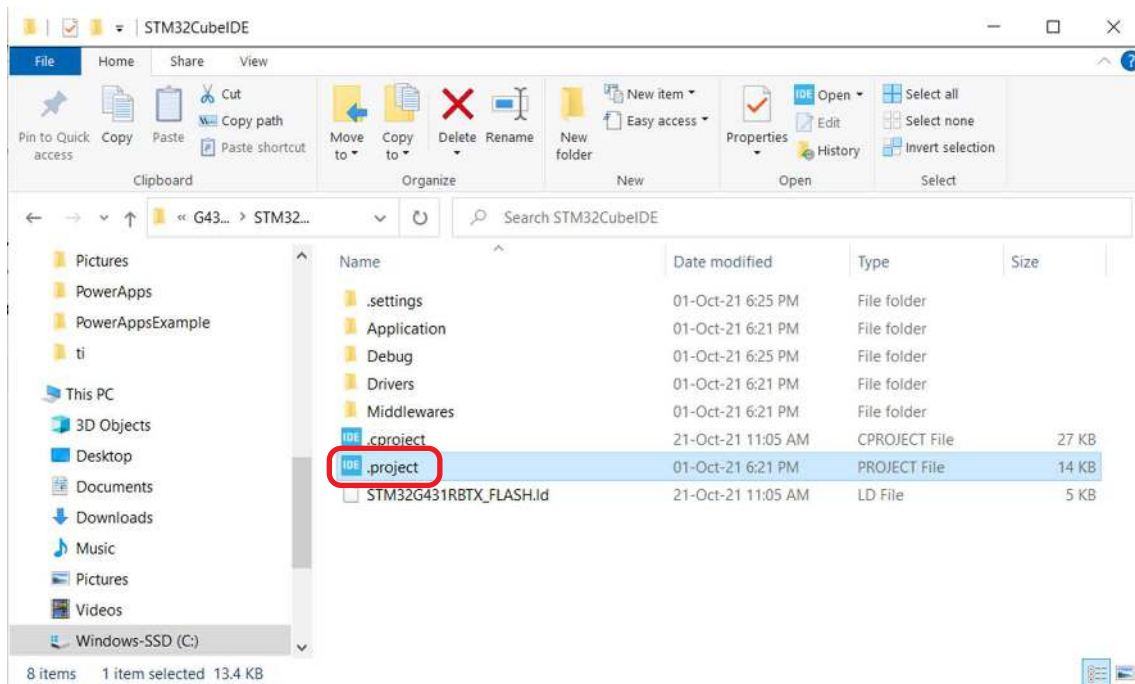

Figure 15: STM32CubeIDE project directory

If this is the first time that the STM32CubeIDE project file is opened, an **Operation completed** dialog box will appear once the installation is completed. Click **OK**. Note: If the project was already imported the following dialog will not appear and the program will open.



Figure 16: Import the .project in the STM32CubeIDE Workspace

Connect the USB cable to the ST Nucleo board on the EPC9147C.

**Highlight the project (1)** in the STM32CubeIDE program and click the **Debug (2)** button as in Figure 17. The entire Compilation, link and flash of the project in the STM32 flash will start (a dialog box may appear, in that case click OK). When the process is finished, the Compiler will enter in Debug mode. Click the **Terminate** button as in Figure 18 and disconnect the USB cable. The STM32CubeIDE program can be closed.

The ST Nucleo Board in the EPC9147C is now ready to run the motor and you can follow the steps described in the quick start procedure paragraph.

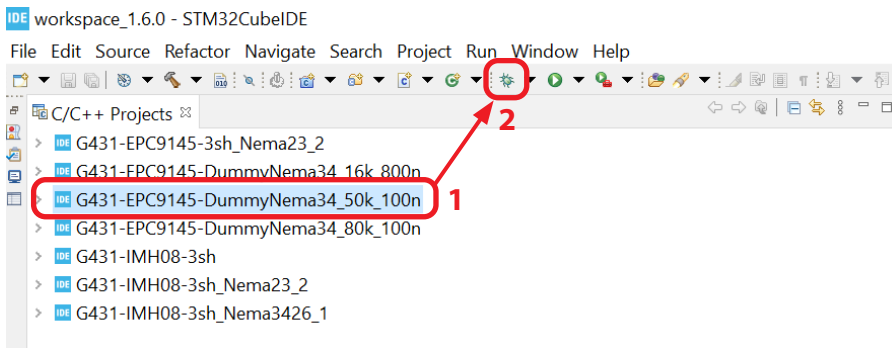

Figure 17: Compile, Build and Flash

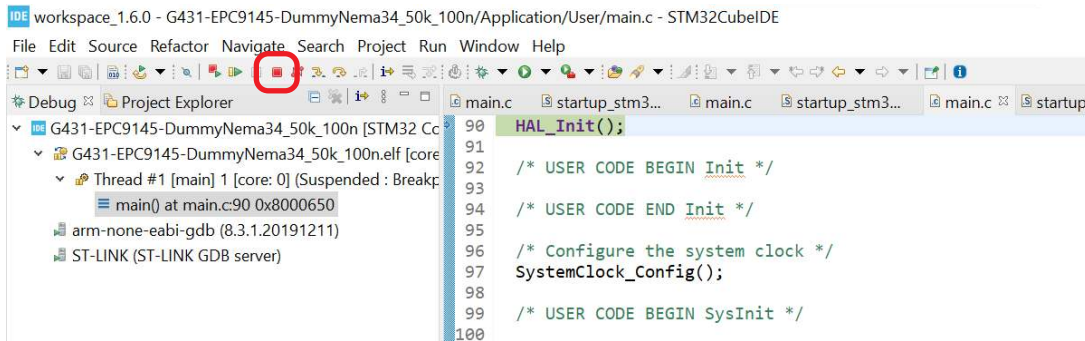

Figure 18: Debugger terminate button

**ST Motor Control Workbench – Advanced Use**

When the ST Nucleo board is properly programmed and connected via the EPC9147C to the proper power board, it is also possible to use the ST Motor Control Workbench GUI to change the speed and the direction of the motor.

Open the **ST Motor Control Workbench** and load the proper **.stmxc** file that is relevant to the project you are working at (e.g. G431-EPC9145-DummyNema34\_50k\_100n.stmxc).

Click on the **Open Monitor** button.

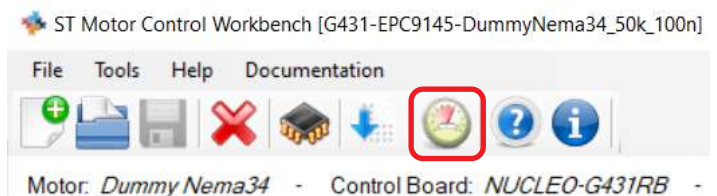

Figure 19: ST Motor Control Workbench Open Monitor button

Connect the USB cable to the PC and power up the 48 V to the power board.

Click on the **Connect** button.



Figure 20: Connect button

Wait for the successful connection message (Figure 21).

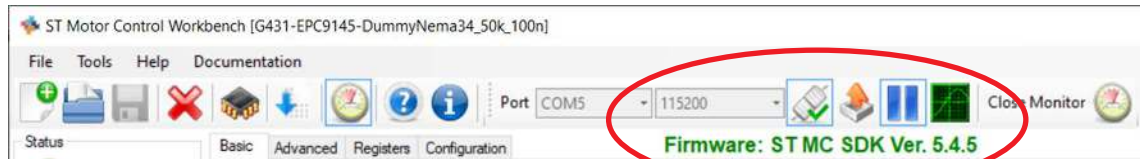

Figure 21: Device successfully connected message

Click **Fault Ack (1)** button if any fault was detected. Then click **Start Motor (2)**. Motor should spin. It is now possible to move the graphic potentiometer on the GUI to change the speed of the motor and to change the motor direction. Refer to [ST user guide manual](#) for more details on how to work with the ST Motor Control Workbench for further customization.

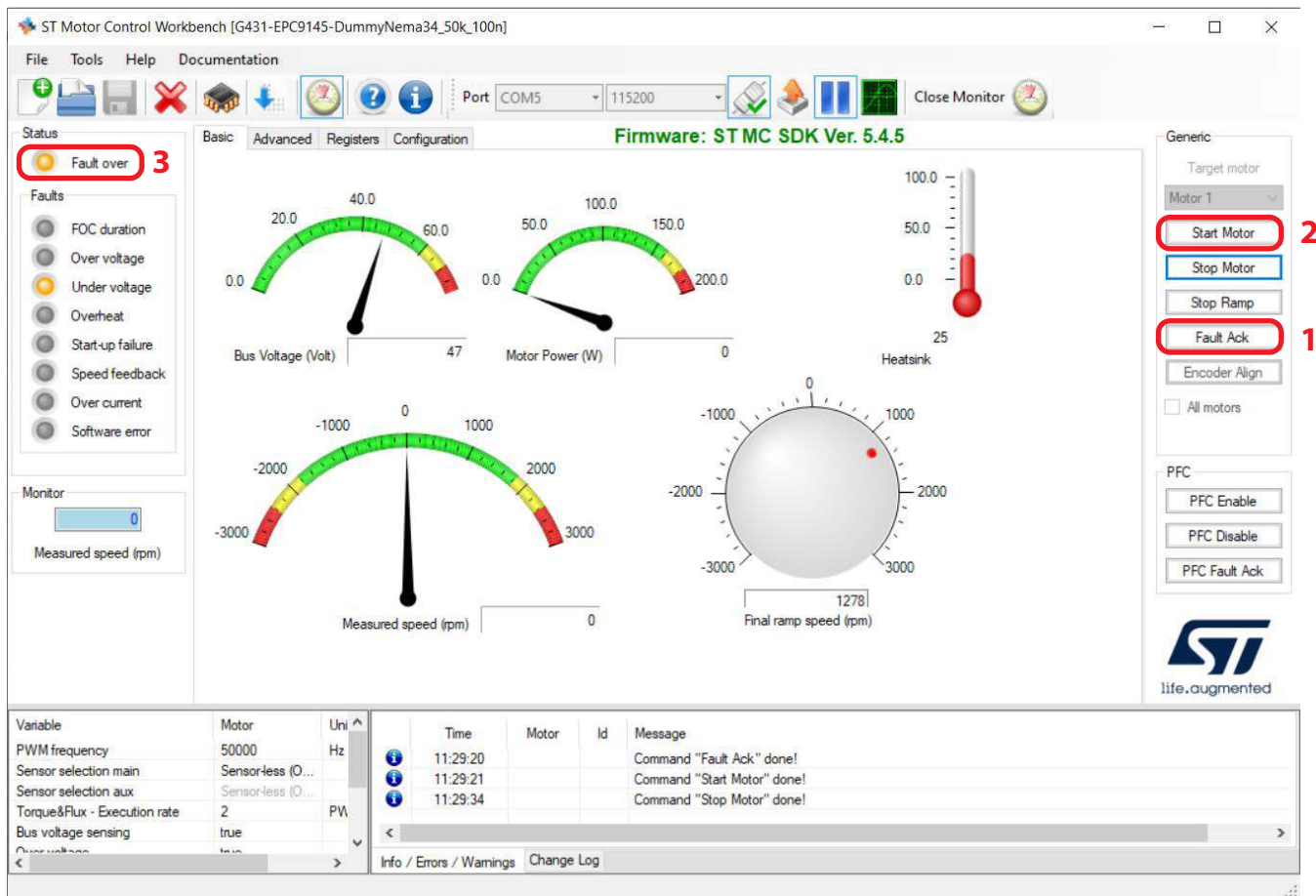

Figure 22: GUI with speed potentiometer. Note the yellow LED "Fault over" (3). Fault Ack (1) must be clicked before starting the motor.

**Table 5: Bill of Materials**

Item	Qty	Reference	Part Description	Manufacturer	Part #
1	1	C1	CAP CER 0.1 µF 16 V X7R 0603	AVX	0603YC104KAT2A
2	3	C2, C3, C4	CAP CER 0.1 µF 16 V X7R 0603	AVX	0603YC104KAT2A
3	1	D1	LED <b>RED</b> CLEAR CHIP SMD	Lite-On	LTST-C193KRKT-5A
4	3	J1, J6, J7		TE	4-103185-0-02
5	1	J2		TE	87227-4
6	1	J3		Sullins	SBH11-PBPC-D17-ST-BK
7	1	J5		Sullins	SFH11-PBPC-D17-ST-BK
8	2	J11, J12	Header Male&Female 100 mil 2 row, 19 pos. thru Vert. Polarized	Samtec	ESQ-119-24-T-D
9	1	P1	TRIMMER 1 k Ω 0.5 W Horz TOP	Vishay	M63P103KB30T607
10	1	R1	RES SMD 1 K Ω 0.1% 1/10W 0603	Yageo	RT0603BRD071KL
11	38	R2, R3, R4, R6, R7, R8, R13, R15, R19, R20, R22, R30, R32, R38, R39, R40, R41, R44, R45, R48, R49, R56, R60, R61, R64, R68, R69, R72, R84, R86, R88, R89, R92, R93, R96, R100, R104, R108	RES 20 K Ω 0.1% 1/10 W 0603, RES SMD 0 Ω JUMPER 1/10 W 0603	Stackpole, Panasonic	RNCF0603BTE20K0, ERJ-3GEY0R00V
12	74	R5, R9, R10, R11, R12, R14, R16, R17, R18, R21, R23, R24, R25, R26, R27, R28, R29, R31, R33, R34, R35, R36, R37, R42, R43, R46, R47, R50, R51, R52, R53, R54, R55, R57, R58, R59, R62, R63, R65, R66, R67, R70, R71, R73, R74, R75, R76, R77, R78, R79, R80, R81, R82, R83, R85, R87, R90, R91, R94, R95, R97, R98, R99, R101, R102, R103, R105, R106, R107, R109, R110, R111, R112, R113	RES SMD 0 Ω JUMPER 1/10 W 0603	Panasonic	ERJ-3GEY0R00V
13	4	SO1, SO2, SO3, SO4	8834 Nylon Standoff	Keystone	8834

**Table 6: Optional Components**

Item	Qty	Reference	Part Description	Manufacturer	Part #
1	3	J8, J9, J10	Jumper 2 pin 50 mil	Harwin	M50-203005

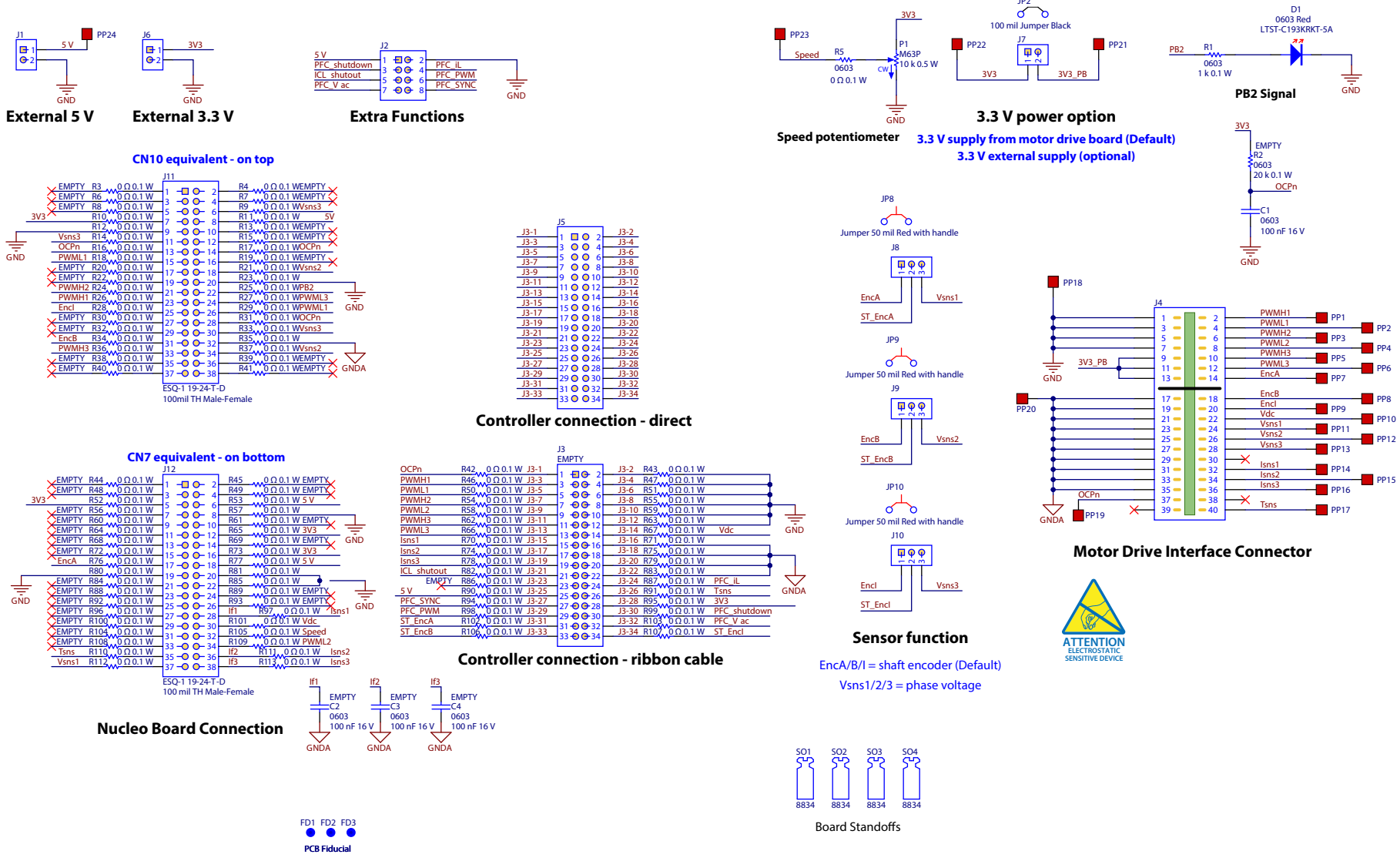

Figure 23: EPC9147C Main schematic

## For More Information:

Please contact [info@epc-co.com](mailto:info@epc-co.com)  
or your local sales representative

Visit our website:  
[www.epc-co.com](http://www.epc-co.com)

Sign-up to receive  
EPC updates at  
[bit.ly/EPCupdates](http://bit.ly/EPCupdates)  
or text "EPC" to 22828



EPC Products are distributed through Digi-Key.  
[www.digikey.com](http://www.digikey.com)

### Demonstration Board Notification

**The EPC9147C board is intended for product evaluation purposes only. It is not intended for commercial use nor is it FCC approved for resale.** Replace components on the Evaluation Board only with those parts shown on the parts list (or Bill of Materials) in the Quick Start Guide. Contact an authorized EPC representative with any questions. This board is intended to be used by certified professionals, in a lab environment, following proper safety procedures. Use at your own risk.

As an evaluation tool, this board is not designed for compliance with the European Union directive on electromagnetic compatibility or any other such directives or regulations. As board builds are at times subject to product availability, it is possible that boards may contain components or assembly materials that are not RoHS compliant. Efficient Power Conversion Corporation (EPC) makes no guarantee that the purchased board is 100% RoHS compliant.

The Evaluation board (or kit) is for demonstration purposes only and neither the Board nor this Quick Start Guide constitute a sales contract or create any kind of warranty, whether express or implied, as to the applications or products involved.

Disclaimer: EPC reserves the right at any time, without notice, to make changes to any products described herein to improve reliability, function, or design. EPC does not assume any liability arising out of the application or use of any product or circuit described herein; neither does it convey any license under its patent rights, or other intellectual property whatsoever, nor the rights of others.