

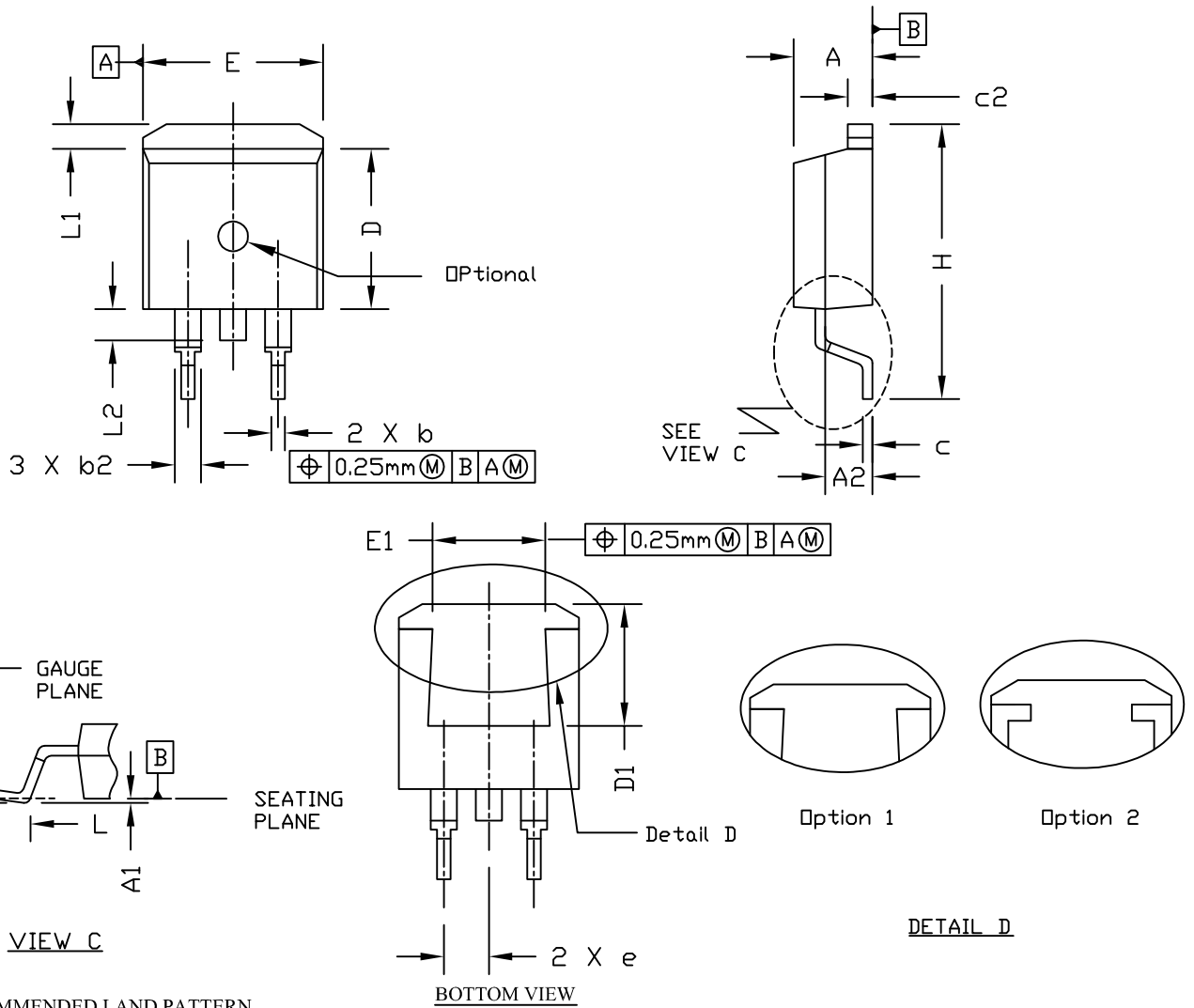

T0263(D2PAK) PACKAGE OUTLINE

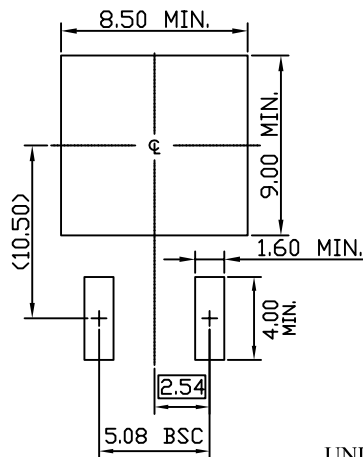

RECOMMENDED LAND PATTERN



UNIT: mm

SYMBOLS	DIMENSIONS IN MILLIMETERS			DIMENSIONS IN INCHES		
	MIN	NOM	MAX	MIN	NOM	MAX
A	4.064	4.45	4.826	0.160	0.175	0.190
A1	0.00	---	0.254	0.000	---	0.010
A2	2.20	2.67	2.90	0.087	0.105	0.114
b	0.508	0.81	0.991	0.020	0.032	0.039
b2	1.143	1.27	1.778	0.045	0.050	0.070
c	0.381	0.50	0.737	0.015	0.020	0.029
c2	1.143	1.27	1.651	0.045	0.050	0.065
D	8.382	9.14	9.652	0.330	0.360	0.380
D1	6.858	8.00	8.37	0.270	0.315	0.330
e	2.54 BSC			0.100 BSC		
E	9.652	10.03	10.668	0.380	0.395	0.420
E1	6.223	8.00	8.37	0.245	0.315	0.330
H	14.605	15.24	15.875	0.575	0.600	0.625
L	1.778	2.54	2.794	0.070	0.100	0.110
L1	1.02	1.27	1.676	0.040	0.050	0.066
L2	1.27	1.52	1.778	0.050	0.060	0.070
L3	0.25 BSC			0.010 BSC		

NOTE:

- PACKAGE BODY SIDES EXCLUDE MOLD FLASH AND GATE BURRS. MOLD FLASH SHOULD BE LESS THAN 6 MILS.
- TOLERANCE 0.10 MILLIMETERS UNLESS OTHERWISE SPECIFIED.
- DIMENSION L IS MEASURED IN GAUGE LINE.
- CONTROLLING DIMENSION IS MILLIMETER.  
CONVERTED INCH DIMENSIONS ARE NOT NECESSARILY EXACT.
- REFER TO JEDEC TO-263 AB.