

THIS DRAWING IS UNPUBLISHED. RELEASED FOR PUBLICATION
 © COPYRIGHT BY TYCO ELECTRONICS CORPORATION. ALL RIGHTS RESERVED.

LOC	DIST	REVISIONS			
P	LTR	DESCRIPTION	DATE	DWN	APVD
GP	00				
	N	REVISED PER ECO-09-001588	25JUN2009	CJV	CWR

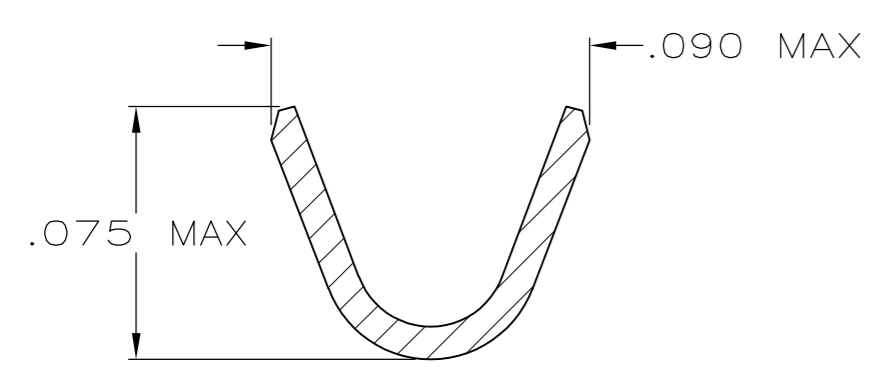

SECTION A-A
SCALE 20:1

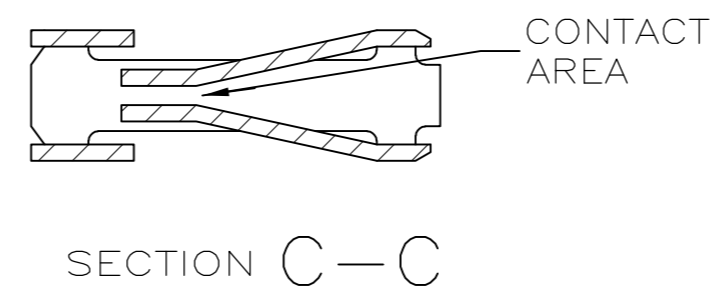
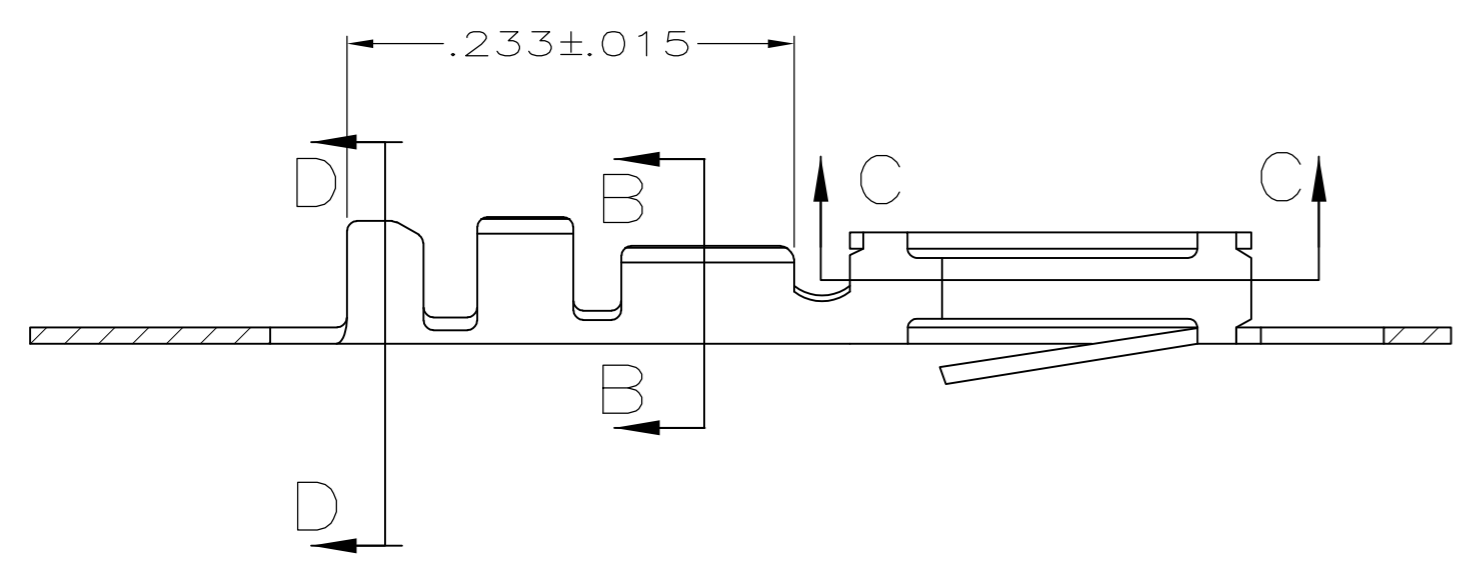
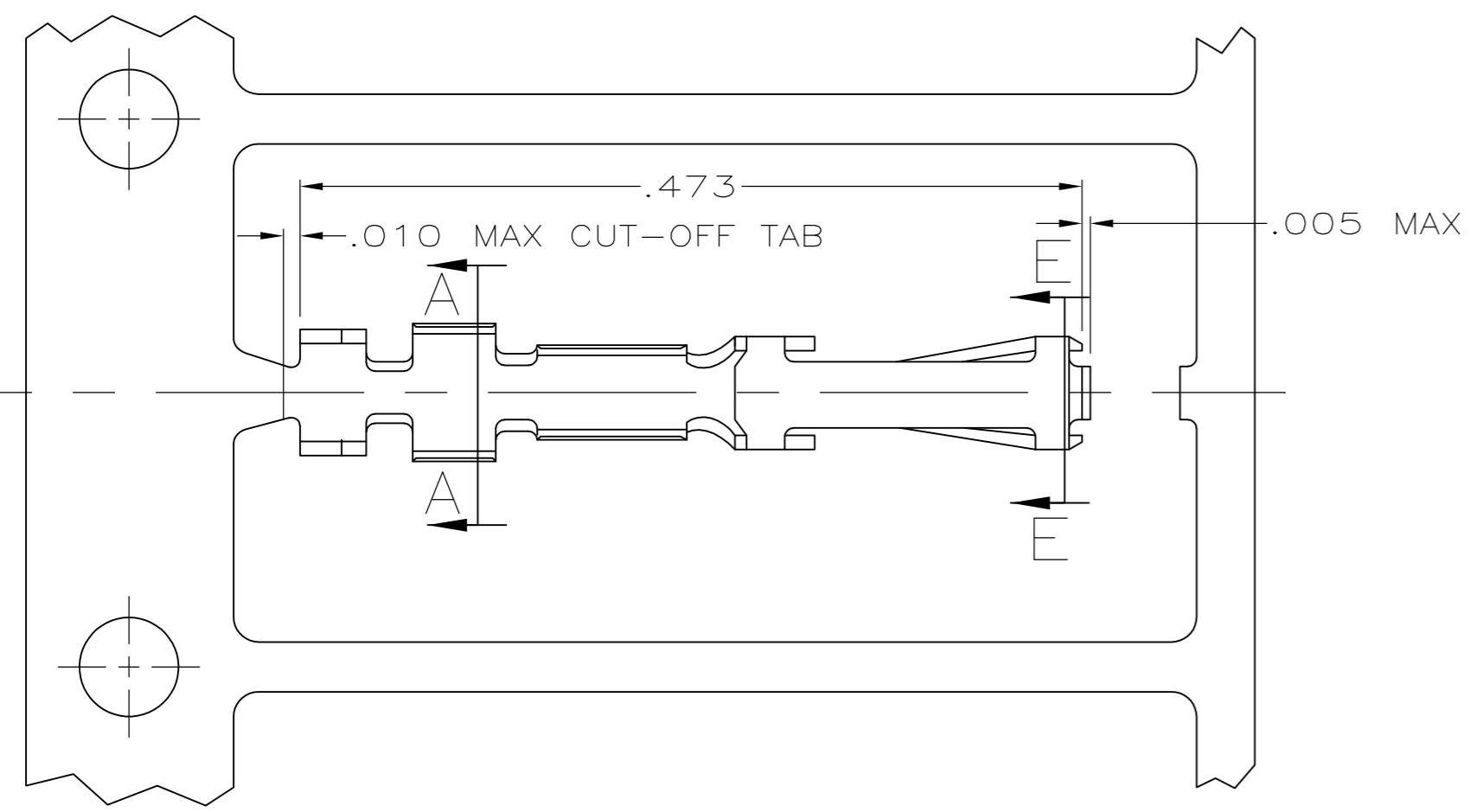
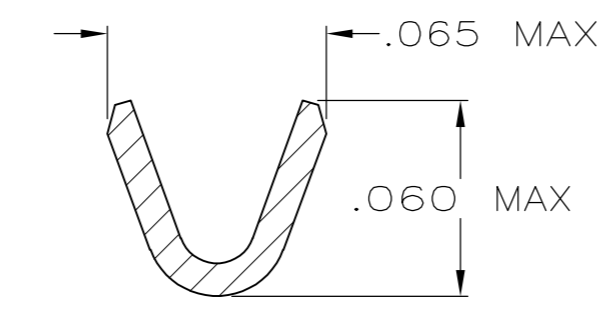

SECTION B-B
SCALE 20:1

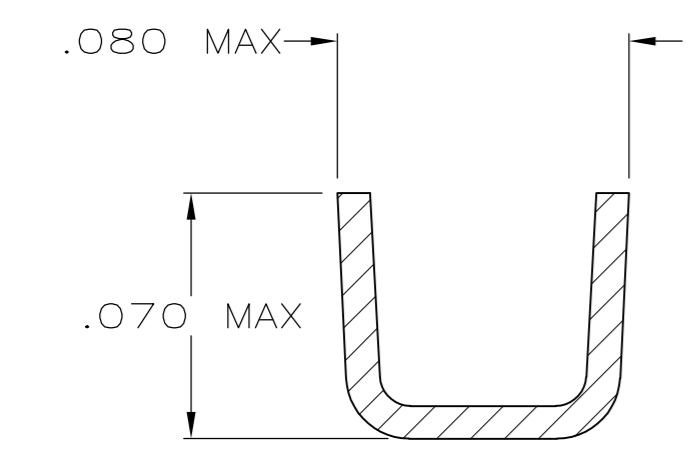

SECTION D-D
SCALE 20:1

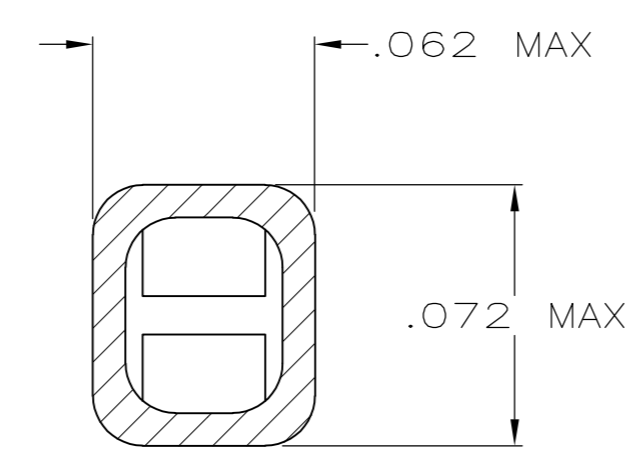

SECTION E-E
SCALE 20:1

- 1 FOR STANDARD APPLICATOR
- 2 FOR MINI APPLICATOR
- 3 FINISH: GOLD FLASH ALL OVER, .000015 MIN THK GOLD ON LOCALIZED CONTACT PLATING AREA OVER .000050 MIN THK NICKEL ON ENTIRE CONTACT.
-OR-
.000050 MIN THK NICKEL UNDERPLATE ON ENTIRE CONTACT, GOLD FLASH OVER PALLADIUM-NICKEL, .000015 MIN TOTAL THK ON LOCALIZED CONTACT PLATING AREA AND GOLD FLASH OVER REMAINDER OF CONTACT.
- 4 FINISH: GOLD FLASH ALL OVER, .000030 MIN THK GOLD ON LOCALIZED CONTACT PLATING AREA OVER .000050 MIN THK NICKEL ON ENTIRE CONTACT.
- 5 FINISH: GOLD FLASH ALL OVER, .000050 MIN THK GOLD ON LOCALIZED CONTACT PLATING AREA OVER .000050 MIN THK NICKEL ON ENTIRE CONTACT.
- 6 FINISH: .000100-.000200 THK BRIGHT TIN-LEAD OVER .000050 MIN THK NICKEL ON ENTIRE CONTACT.
- 7. FOR 26-32 AWG WIRE WITH AN INSULATION RANGE OF .025-.048 DIA.
- 8 OBSOLETE PART NUMBER

	LOOSE PIECE	5	8	1-88017-9
	LOOSE PIECE	6	8	1-88017-7
		2	6	1-88017-6
		1	6	1-88017-5
		2	5	1-88017-4
		1	5	1-88017-2
		1	4	1-88017-1
		1	3	1-88017-0
	LOOSE PIECE	5	8	88017-8
SUPSD BY 88017-6	LOOSE PIECE	4		88017-7
	LOOSE PIECE	3		88017-6
SUPSD BY 88017-2		2	5	88017-4
		2	4	88017-3
		2	3	88017-2
	REMARKS	FINISH	PART NO.	

THIS DRAWING IS A CONTROLLED DOCUMENT.		DWN B. MOYER 6-8-89	Tyco Electronics Corporation Harrisburg, PA 17105-3608	
DIMENSIONS: INCHES		CHK D.L. ROCKER 6-8-89	NAME	
TOLERANCES UNLESS OTHERWISE SPECIFIED: 0 PLC ± - 1 PLC ± - 2 PLC ± - 3 PLC ± .005 4 PLC ± - ANGLES ± -		APVD -	PRODUCT SPEC 108-9024	
MATERIAL PHOS. BRONZE		FINISH SEE TABLE	APPLICATION SPEC 114-16003	RESTRICTED TO -
		WEIGHT -	SIZE A2	CAGE CODE 00779
		CUSTOMER DRAWING	DRAWING NO C=88017	SCALE 10:1
			SHEET 1 of 1	REV N