

**STRAIGHT SQUARE FLANGE JACK SOLDER TYPE
CABLE .141**

**R124.255.003
SERIES SMA-COM**

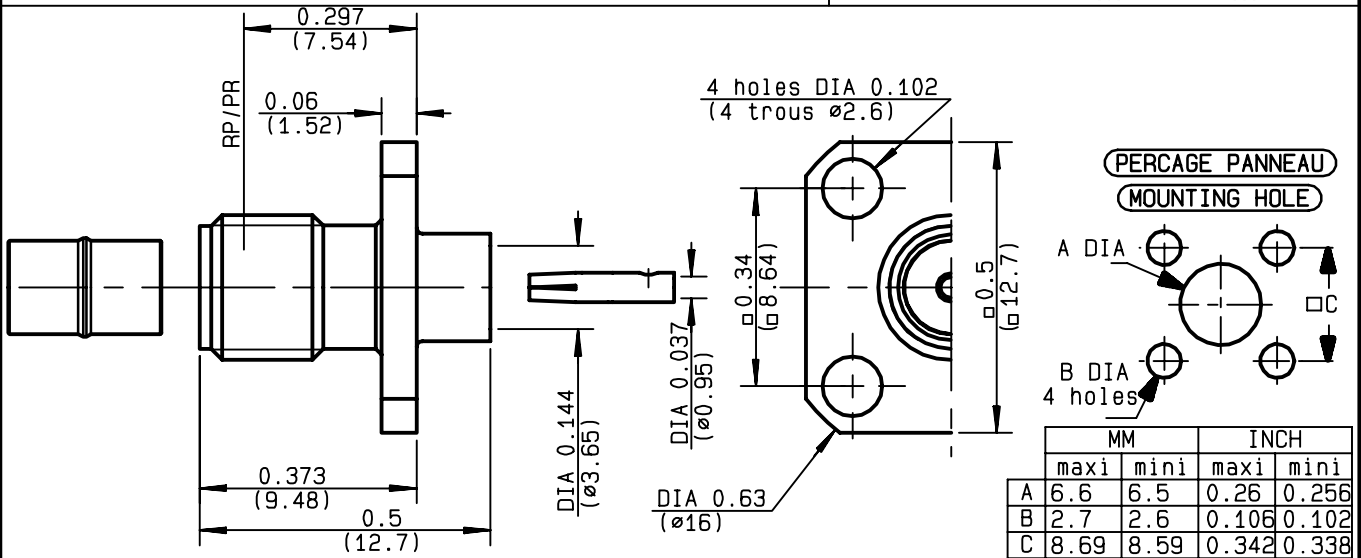

NOMINAL IMPEDANCE	50	Ω
FREQUENCY RANGE	0-18	GHz
TEMPERATURE RATING	-65/+105	$^{\circ}\text{C}$
V.S.W.R	1.05 + .01 x F(GHz)Maxi	
RF INSERTION LOSS	0.05 \sqrt{F} (GHz) dB Maxi	
VOLTAGE RATING	500	Veff Maxi
DIELECTRIC WITHSTANDING VOLTAGE	1000	Veff Mini
INSULATION RESISTANCE	5000	M Ω Mini
HERMETIC SEAL	NA	Atm.cm ³ /s
LEAKAGE (pressurized only)	NA	
MECHANICAL DURABILITY	100	Cycles
WEIGHT	2.7	gr
SPECIFICATION		

CABLES : **KS 2**
RG 402

OTHERS CHARACTERISTICS

CABLE RETENTION	270	N Mini
CENTER CONTACT RETENTION		
Axial force - mating end	NA	N Mini
Axial force - opposite end	NA	N Mini
Torque	NA	cm.N Mini
RECOMMENDED TORQUES		
Mating	NA	cm.N
Panel nut	NA	cm.N
Clamp nut	NA	cm.N

CONNECTOR PARTS	MATERIALS	FINISH	(all values are given in micrometers)
BODY	BRASS	GOLD 0.2 OVER NICKEL 2	
OUTER CONTACT			
CENTER CONTACT	BERYLLIUM COPPER	GOLD 1.3 OVER COPPER 2.5	
INSULATOR	PTFE	-	
GASKET		-	
OTHERS PIECES			

ISSUE	CREATION DATE	FILE PART-NUMBER
9847A00	19/06/1996	96-1200-070



RADIALL[®]

TRIQUES

The information given here is subject to change without notice.
Design changes may be in order to improve the product .

Connect to the future



R124.255.003

ISSUE **9847A00** SERIES **SMA-COM**

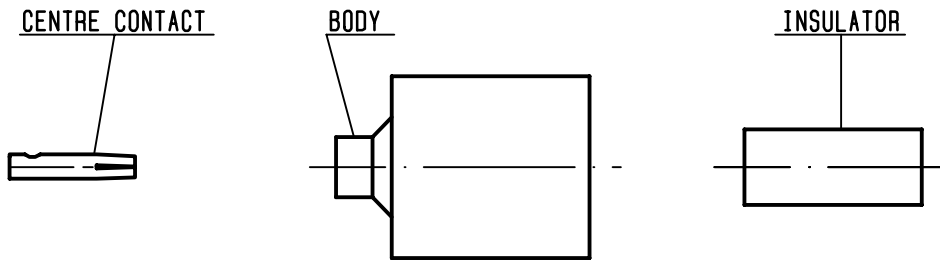

We recommend a cable thermal preconditioning before assembling

- Strip the dielectric of the cable .
Stripping tool cable : R282.053.000
Trimmer : R282.067.000
Clean the cable .
-

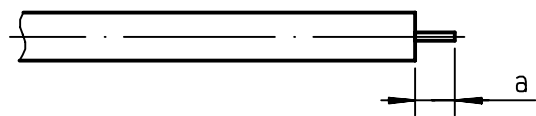

Stripping	a	b	c	d	e
inch	0.125 0	0	0	0	0
mm	3.17				

- Screw the positioner R282.744.220 onto the soldering jig R282.740.000
Slide contact into positioner .
Insert solder gauge R282.862.060 (62) between contact and cable .
Tighten and solder the contact .

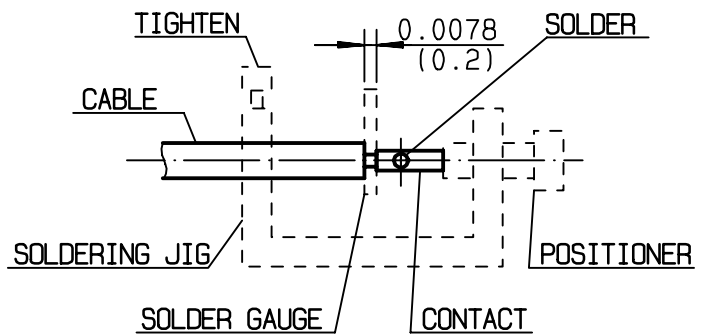

- After cooling remove cable assembly from the jig .
Screw positioner R282.744.011 (86) into the connector .
Slide cable into the connector until it bottoms againsts positioner R282.744.011 .
Tighten .
Put 3 rings of solder around the cable and solder .

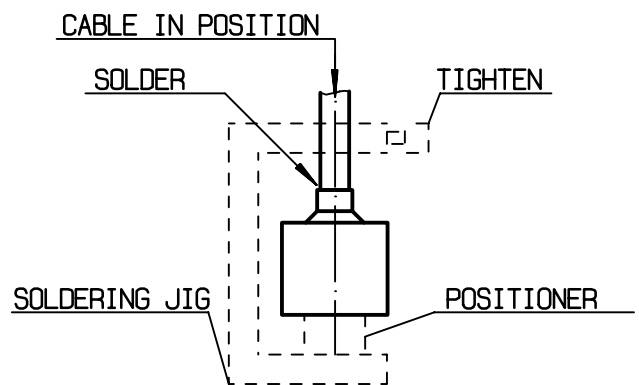

- After cooling remove cable assembly from the jig .
Screw positioner cut R282.914.010
Cut the dielectric flush to clamp braid sleeve with tool R282.915.010.
Screw female dielectric insert tool onto connector and insert insulator with the dielectric plunger R282.730.043

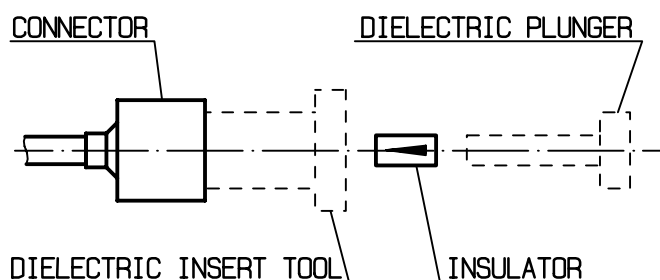

TRIQUES