

REV.	DESCRIPTION	DATE	APPROVED
E	Engineering Update w/o Changes	03/08/04	M. C.

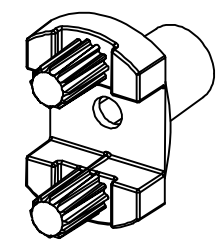
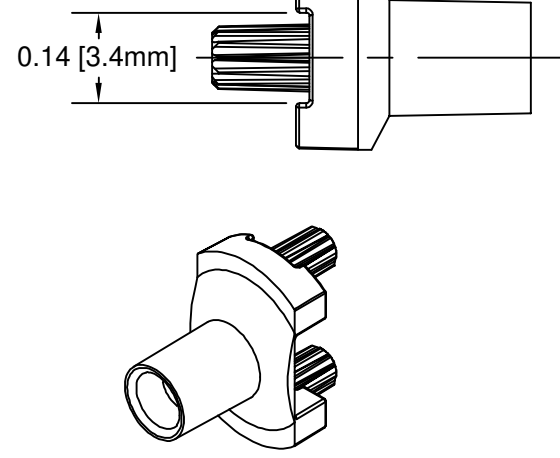
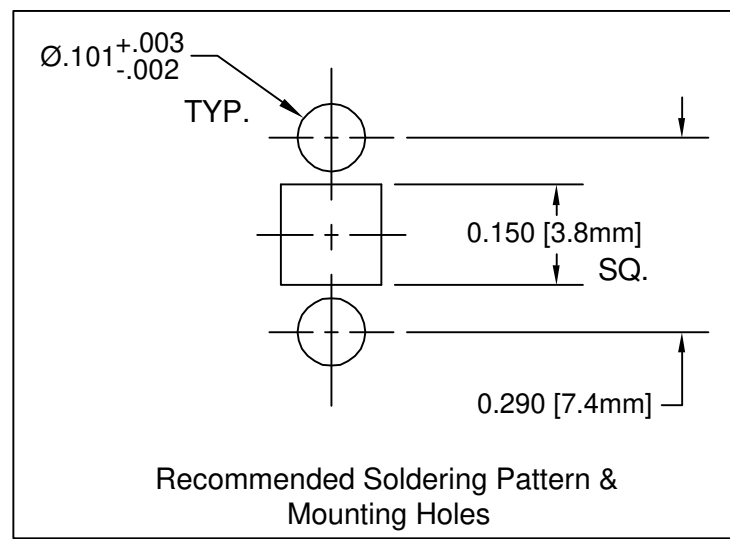
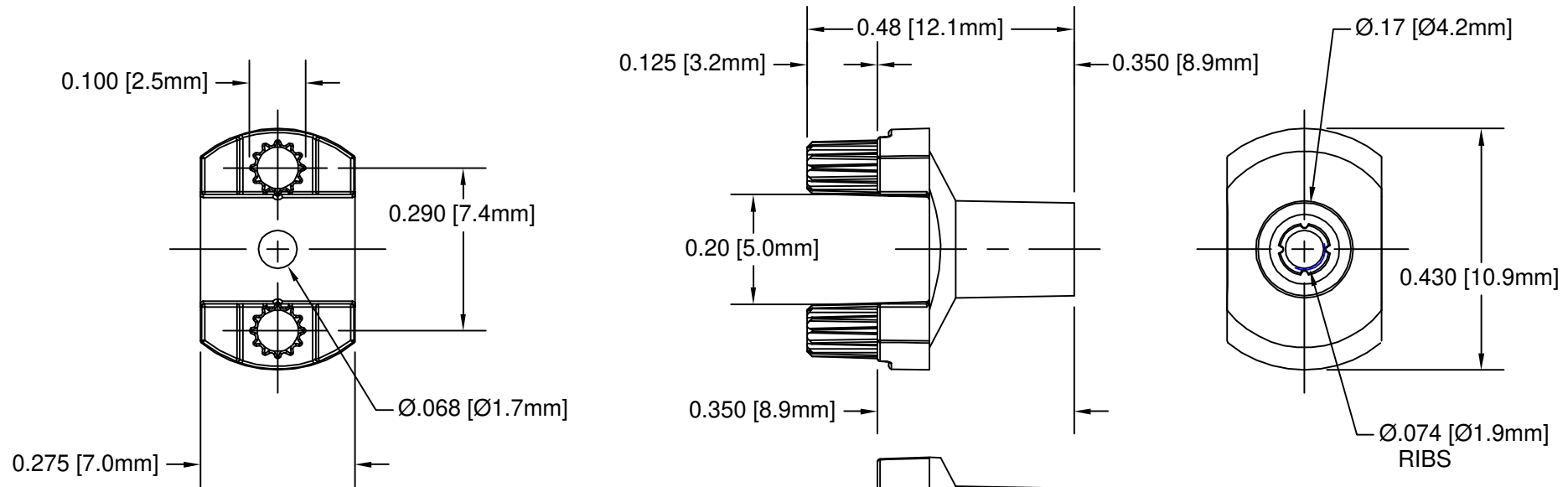

2. MATERIAL: NYLON 6/6 , 94V-0, BLACK, BIVAR MATERIAL CODE 22-BK RTP POLYAMIDE NYLON 6/6, RTP 0200 FR BLACK
1. GENERAL SPECIFICATIONS: BIVAR MOLDED COMPONENT SPECIFICATION BV00-E101.

STANDARD TOLERANCE (UNLESS OTHERWISE SPECIFIED)		BIVAR®	
DECIMALS	ANGULAR	4 THOMAS, IRVINE, CA. 92618	
.X ±.1	X° ±1°	TEL: (949) 951-8808 FAX: (949) 951-3974	
.XX ±.01		TITLE: ADAPTER, SURFACE MOUNT FLEXIBLE LIGHT PIPE	
.XXX ±.005		PART NO: SMFLP	REVISION: E
DESIGNED: Michael Chen	DATE: 01/15/02	CAGE CODE : 32559	SHEET # 1 OF 1
CHECKED: E. M. Muldoon	DATE: 02/18/02	CAD GENERATED DOCUMENT, DO NOT MEASURE DRAWING.	