

Order Number
63808-2800

molex[®]

Application Tooling Specification

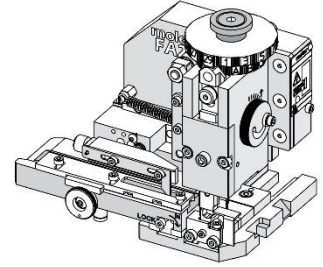

FEATURES

- Applicator designed to industry-standard mounting and 135.80mm (5.346") shut height
- Quick setup time; plus, the crimp height, track and feed adjustments can be set without removing the applicator from the press
- Fine adjustment allows users to achieve target with little effort by adjusting in increments of .015mm (.0006") for conductor crimp height and .025mm (.001") for insulation height
- Fine adjustment of the bend is achieved using the bend adjust dial
- Independent adjustment rings allow users to quickly adjust the conductor or insulation crimp height without affecting each other
- Directly adapts to most automatic wire processing machines
- Crimped terminal checking aid (63808-2008) can be ordered separately

SCOPE

Products: MX150 18 Grip Receptacle for 18 AWG and 1.00mm² Wire.

Terminal Series No.	Terminal Order No.	Wire		Insulation Diameter		Strip Length	
		Wire Type	Wire Size	mm	In.	mm	In.
33001 33012 34750	33001-3004	TXL	18 AWG	1.60-2.54	.063-.100	4.70-5.60	.185-.220
	33001-5002	GXL	18 AWG				
	33012-3002	PSA FTP 00949_10_00769	1.00mm ²				
	34750-1002	FLR91X_A_XLPO	1.00mm ²				
	33012-3022	ISO	1.00mm ²				
	33012-5022						
33001-3022							
33001-5022							

DEFINITION OF TERMS

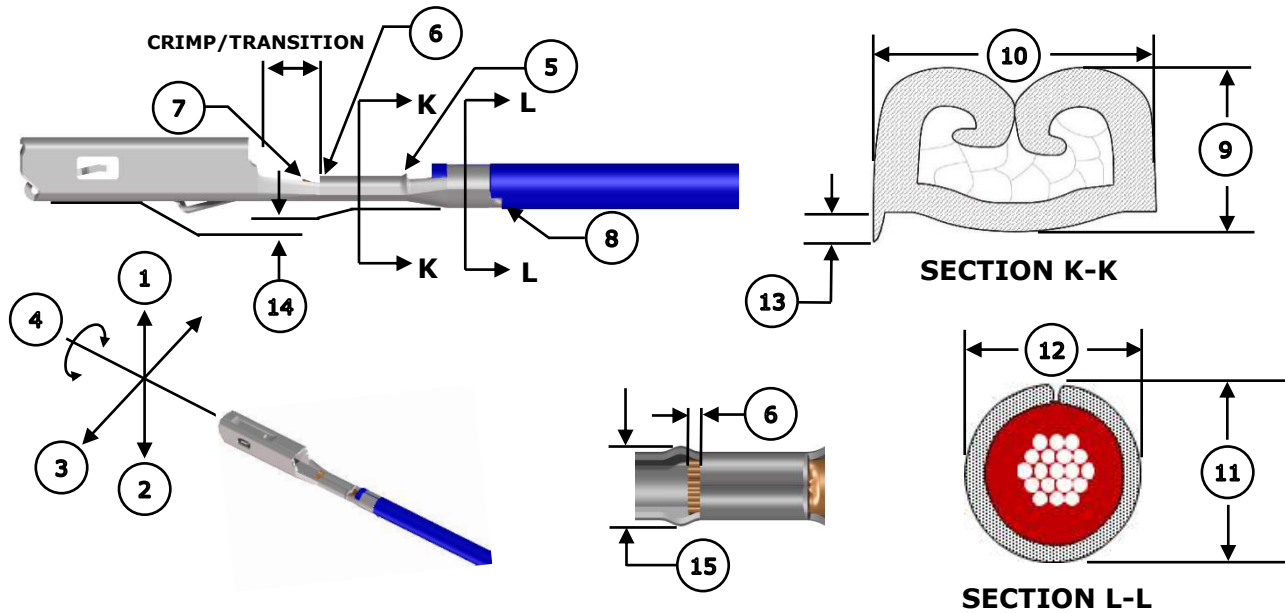

CRIMP SPECIFICATIONS

The following crimp specifications are based on document AS-33012-002 Rev. E:

Feature	Requirement																																				
1. Bend Up	3° Max																																				
2. Bend Down	3° Max																																				
3. Twist	3° Max																																				
4. Roll	3° Max																																				
5. Bell Mouth Rear	0.30-0.70mm (.012-.028")																																				
6. Bell Mouth Front	Not Applicable																																				
7. Conductor Brush	0.40mm (.016") Max Not to extend above conductor crimp/transition height																																				
8. Cut-Off Tab	0.50mm (.020") Max																																				
Conductor Crimp	<table border="1"> <thead> <tr> <th>Wire Type</th> <th>Wire Size</th> <th colspan="2">9. Crimp Height</th> <th colspan="2">10. Crimp Width</th> </tr> </thead> <tbody> <tr> <td>TXL</td> <td>18 AWG</td> <td>1.20-1.30mm</td> <td>.047-.051 in.</td> <td>2.05-2.25mm</td> <td>.081-.089 in.</td> </tr> <tr> <td>GXL</td> <td>18 AWG</td> <td>1.20-1.30mm</td> <td>.047-.051 in.</td> <td>2.05-2.25mm</td> <td>.081-.089 in.</td> </tr> <tr> <td>PSA FTP 00949_10_00769</td> <td>1.00mm²</td> <td>1.30-1.40mm</td> <td>.051-.055 in.</td> <td>2.05-2.25mm</td> <td>.081-.089 in.</td> </tr> <tr> <td>FLR91X_A_XLPO</td> <td>1.00mm²</td> <td>1.30-1.40mm</td> <td>.051-.055 in.</td> <td>2.05-2.25mm</td> <td>.081-.089 in.</td> </tr> <tr> <td>ISO</td> <td>1.00mm²</td> <td>1.25-1.35mm</td> <td>.049-.053 in.</td> <td>2.05-2.25mm</td> <td>.081-.089 in.</td> </tr> </tbody> </table>	Wire Type	Wire Size	9. Crimp Height		10. Crimp Width		TXL	18 AWG	1.20-1.30mm	.047-.051 in.	2.05-2.25mm	.081-.089 in.	GXL	18 AWG	1.20-1.30mm	.047-.051 in.	2.05-2.25mm	.081-.089 in.	PSA FTP 00949_10_00769	1.00mm ²	1.30-1.40mm	.051-.055 in.	2.05-2.25mm	.081-.089 in.	FLR91X_A_XLPO	1.00mm ²	1.30-1.40mm	.051-.055 in.	2.05-2.25mm	.081-.089 in.	ISO	1.00mm ²	1.25-1.35mm	.049-.053 in.	2.05-2.25mm	.081-.089 in.
	Wire Type	Wire Size	9. Crimp Height		10. Crimp Width																																
	TXL	18 AWG	1.20-1.30mm	.047-.051 in.	2.05-2.25mm	.081-.089 in.																															
	GXL	18 AWG	1.20-1.30mm	.047-.051 in.	2.05-2.25mm	.081-.089 in.																															
	PSA FTP 00949_10_00769	1.00mm ²	1.30-1.40mm	.051-.055 in.	2.05-2.25mm	.081-.089 in.																															
FLR91X_A_XLPO	1.00mm ²	1.30-1.40mm	.051-.055 in.	2.05-2.25mm	.081-.089 in.																																
ISO	1.00mm ²	1.25-1.35mm	.049-.053 in.	2.05-2.25mm	.081-.089 in.																																
Insulation Crimp	<table border="1"> <thead> <tr> <th>Wire Type</th> <th>Wire Size</th> <th colspan="2">11. Crimp Height</th> <th colspan="2">12. Crimp Width</th> </tr> </thead> <tbody> <tr> <td>TXL</td> <td>18 AWG</td> <td>1.90-2.10mm</td> <td>.075-.083 in.</td> <td>2.20-2.40mm</td> <td>.087-.094 in.</td> </tr> <tr> <td>GXL</td> <td>18 AWG</td> <td>2.30-2.50mm</td> <td>.091-.098 in.</td> <td>2.50-2.70mm</td> <td>.098-.106 in.</td> </tr> <tr> <td>PSA FTP 00949_10_00769</td> <td>1.00mm²</td> <td>2.25-2.35mm</td> <td>.089-.093 in.</td> <td>2.20-2.40mm</td> <td>.087-.094 in.</td> </tr> <tr> <td>FLR91X_A_XLPO</td> <td>1.00mm²</td> <td>2.30-2.40mm</td> <td>.091-.093 in.</td> <td>2.20-2.40mm</td> <td>.087-.094 in.</td> </tr> <tr> <td>ISO</td> <td>1.00mm²</td> <td>2.30-2.40mm</td> <td>.091-.094 in.</td> <td>2.20-2.40mm</td> <td>.087-.094 in.</td> </tr> </tbody> </table>	Wire Type	Wire Size	11. Crimp Height		12. Crimp Width		TXL	18 AWG	1.90-2.10mm	.075-.083 in.	2.20-2.40mm	.087-.094 in.	GXL	18 AWG	2.30-2.50mm	.091-.098 in.	2.50-2.70mm	.098-.106 in.	PSA FTP 00949_10_00769	1.00mm ²	2.25-2.35mm	.089-.093 in.	2.20-2.40mm	.087-.094 in.	FLR91X_A_XLPO	1.00mm ²	2.30-2.40mm	.091-.093 in.	2.20-2.40mm	.087-.094 in.	ISO	1.00mm ²	2.30-2.40mm	.091-.094 in.	2.20-2.40mm	.087-.094 in.
	Wire Type	Wire Size	11. Crimp Height		12. Crimp Width																																
	TXL	18 AWG	1.90-2.10mm	.075-.083 in.	2.20-2.40mm	.087-.094 in.																															
	GXL	18 AWG	2.30-2.50mm	.091-.098 in.	2.50-2.70mm	.098-.106 in.																															
	PSA FTP 00949_10_00769	1.00mm ²	2.25-2.35mm	.089-.093 in.	2.20-2.40mm	.087-.094 in.																															
FLR91X_A_XLPO	1.00mm ²	2.30-2.40mm	.091-.093 in.	2.20-2.40mm	.087-.094 in.																																
ISO	1.00mm ²	2.30-2.40mm	.091-.094 in.	2.20-2.40mm	.087-.094 in.																																

Pull Force	Wire Type	Wire Size	Minimum Force		To be measured with no influence from the insulation crimp
	TXL	18 AWG	90 N	20.3 lb.	
	GXL	18 AWG	90 N	20.3 lb.	
	PSA FTP 00949_10_00769	1.00mm ²	115 N	25.9 lb.	
	FLR91X_A_XLPO	1.00mm ²	120 N	27.0 lb.	
	ISO	1.00mm ²	120 N	27.0 lb.	
13. Conductor Anvil Flash	0.22mm (.009") Max				
14. Insulation Grip Step	0.20-0.40mm (.008-.016")				
15. Crimp Bulge	2.65mm (.104") Max				

NOTES

Applicator Notes

- This applicator is for automatic wire processor use only.
- This applicator does not include a cutting insert.
- Installing a cutting insert will cause jamming in this applicator.

CUTTING INSERT

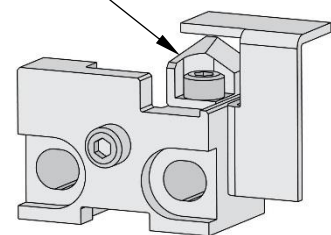

Specification Notes

- It is very important that the brush length is consistently within specification for this sealed connector system to work properly.
- This applicator should only be run in a properly set up wire processor to consistently achieve the brush length.

General Notes

1. Molex recommends that an extra perishable tooling kit be maintained at your facility.
2. Verify tooling alignment by hand cycling the press and applicator before crimping under power. Check that all screws are tight.
3. Slugs, terminals, dirt and oil should be kept clear of the work area.
4. Wear safety glasses at all times.
5. For recommended maintenance, refer to the FA2 manual (TM-638080200).
6. Molex recommends crimping stranded copper wire only.
7. Lubrication must be used when crimping gold and select gold terminals to prevent terminals from sticking in the conductor punch. Use 63801-7240 oiler or equivalent.

WARNINGS

CAUTION: This applicator must be installed in a press with a standard shut height of 135.80mm (5.346"). Tooling damage could result at a lower setting.

CAUTION: To prevent injury, never operate this applicator without the guards supplied with the press or wire-processing machine in place. Reference the press or wire processing manufacturer's instruction manual.

CAUTION: Molex tooling crimp specifications are valid only when used with Molex terminals and tooling manufactured by Molex and sold by Molex or authorized distributors ("Molex Tooling"). When using tooling other than Molex Tooling with Molex-specific connector systems listed in our ATS documents, the Molex Tooling qualification does not apply, and the responsibility for full qualification of the connector system is that of the customer. Molex accepts no liability for connector performance or tooling support where tooling other than Molex Tooling is used or where Molex Tooling is modified.

PARTS LIST

New Frame Applicator 63808-2800				
Item	Order No.	Engineering No.	Description	Quantity
Perishable Tooling				
	63808-2870	63808-2870	Tool Kit (All "Y" Items)	Ref
1	63454-0048	63454-0048	Insulation Punch	1 Y
2	63457-0117	63457-0117	Conductor Punch	1 Y
3	63456-0124	63456-0124	Insulation Anvil	1 Y
4	63455-0145	63455-0145	Conductor Anvil	1 Y
5	63443-0034	63443-0034	Cut-Off Plunger	1 Y
Non-Perishable Components				
6	63443-0128	63443-0128	Front Plunger Retainer	1
7	11-24-1067	4996-4	Cut-Off Plunger Spring	1
8	63443-0117	63443-0117	Front Scrap Chute	1
9	63443-7502	63443-7502	Anvil Mount	1
10	63443-0090	63443-0090	Wire Stop	1
11	63443-3601	63443-3601	Front Plunger Striker	1
12	63443-3702	63443-3702	Wire Hold Down Plunger	1
13	63600-5776	63600-5776	Nose Hold Down	1
14	63600-5775	63600-5775	Nose Hold Down Shank	1
15	63443-4714	63443-4714	Terminal Guide	1
16	63808-0220	63808-0220	Hold Down Block	1
17	63808-0229	63808-0229	Bend Adjust Dial	1
18	63808-0297	63808-0297	Feed Cam	1
Frame				
19	63808-0200	63808-0200	Applicator Core	1
20	63808-0197	63808-0197	Mechanical Feed Assembly	1
21	63808-0190	63808-0190	Track Assembly	1
Hardware				
22	—	—	M2.5 x 4 SHCS	1*
23	—	—	M3 Flat Washer	1*
24	—	—	M3 Star Washer	1*
25	—	—	M3 x 3 SSS	2*
26	—	—	M3 x 6 BHCS	2*
27	—	—	M3 x 12 SHCS	4*
28	—	—	M4 x 6 SHCS	1*
29	—	—	M4 x 6 SSS	1*
30	—	—	M4 x 8 SHCS	2*
31	—	—	M4 x 50 SHCS	2*
32	—	—	M5 x 12 SHCS	1*
33	—	—	#10-32UNF x .25" SHCS	1*
*Fastener parts can be purchased through most industrial suppliers by using the description in the table above.				

ASSEMBLY DRAWING

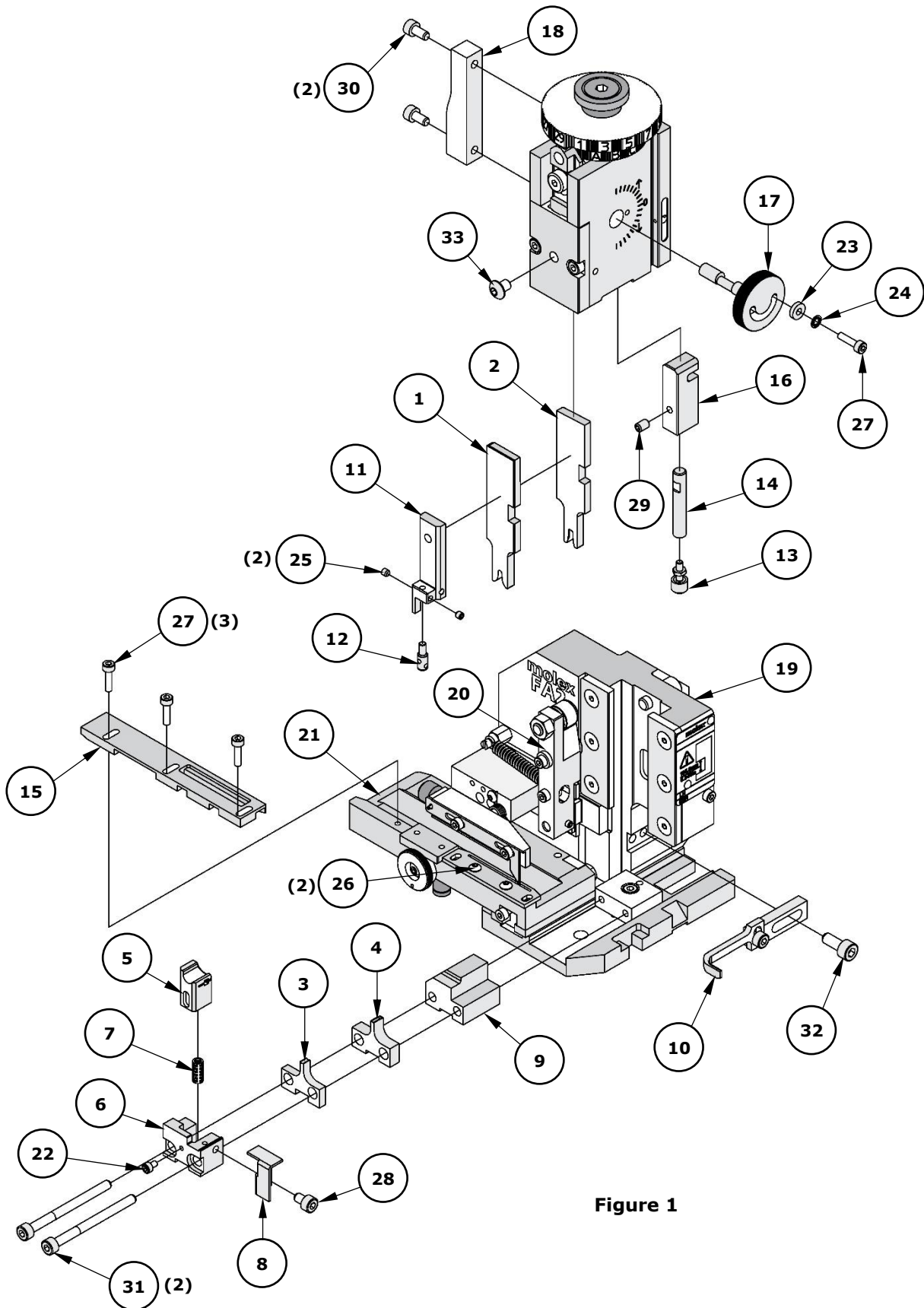

Figure 1

FACTORY SETTINGS

Feed Pawl Assembly

The FA2 applicator number 63808-2800 ships with the following factory settings. See Figure 2:

- The feed pawl shaft and M3 screw that holds the feed pawl spring are in position 3.
- The pin is in position C.

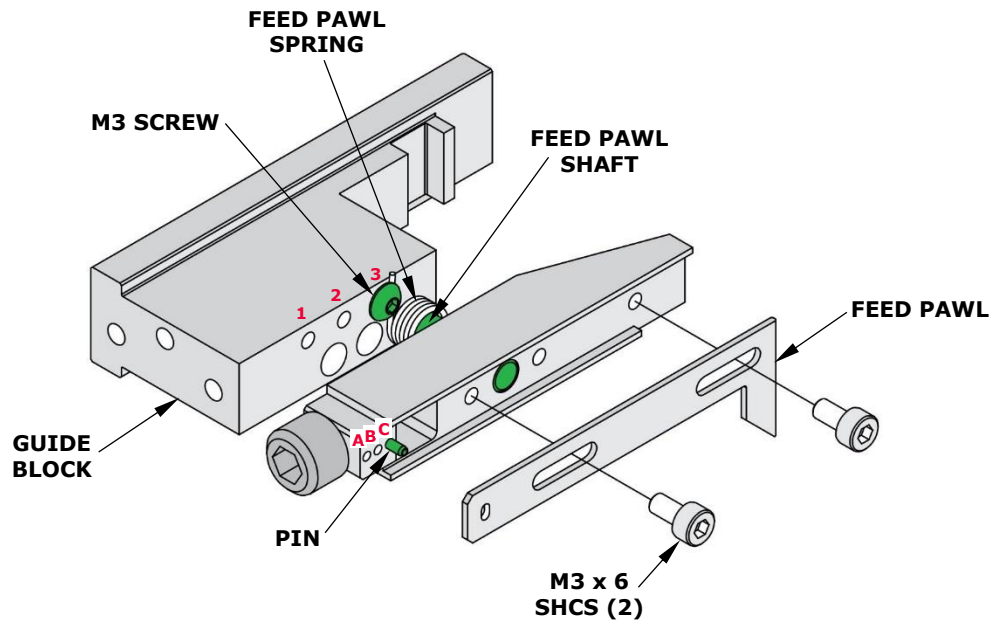

Note

Figure 2

This information is included as a reference only. Each applicator is configured and tested by Molex prior to shipping, and the above settings were used to produce the included sample crimps.

Third Dial/Ram Assembly

○ Indicates item number on the Parts List and Assembly Drawing

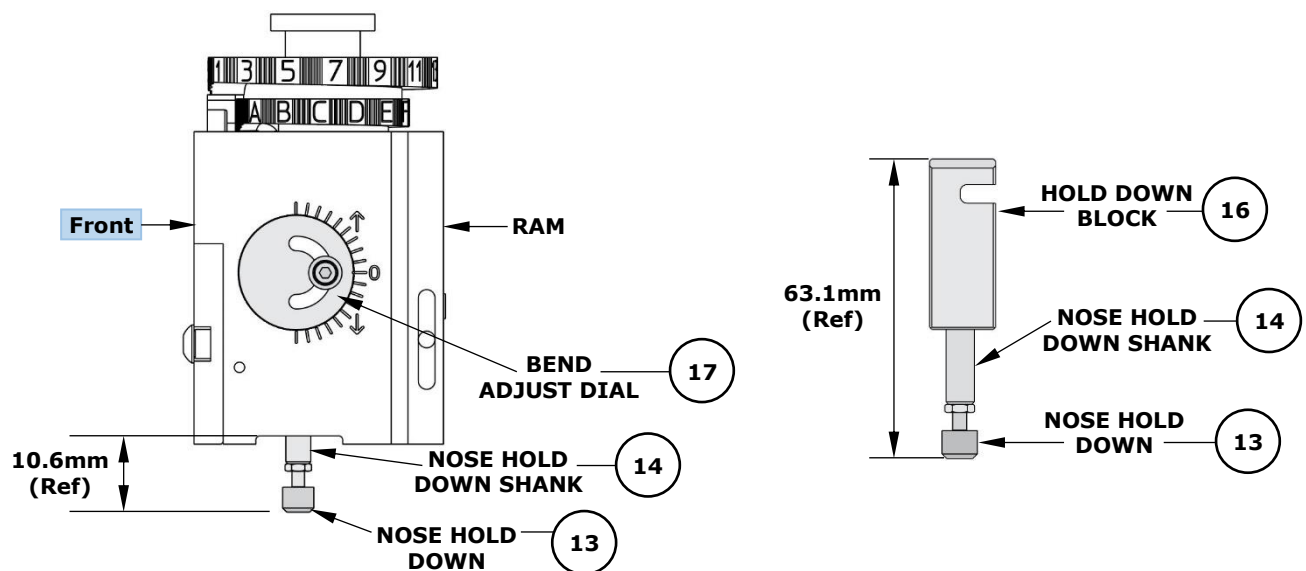

Mounting Datum Location

This applicator was assembled and tested by Molex with the mounting datum in the location shown in Figure 4. Do not remove the mounting datum.

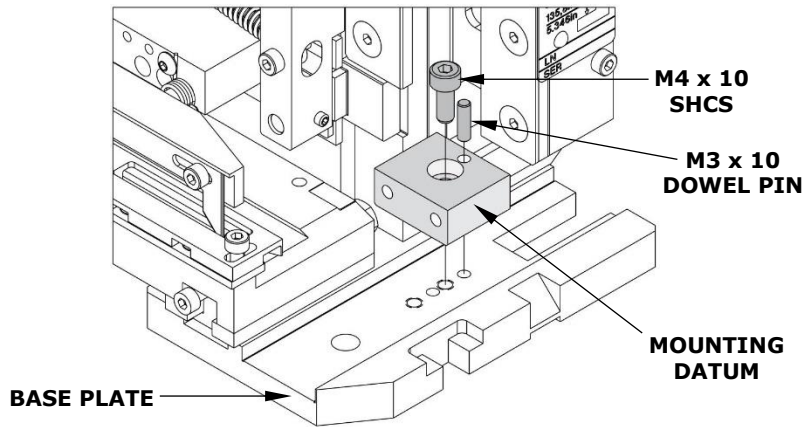

Figure 4

Application Tooling Support

Phone: (402) 458-TOOL (8665)

E-Mail: applicationtooling@molex.com

Website: www.molex.com/applicationtooling

Molex is a registered trademark of Molex, LLC in the United States of America and may be registered in other countries; all other trademarks listed herein belong to their respective owners.