

LOC		DIST		REVISIONS			
AF	50	REV	DATE	BY	APPV		
F1		REVISED PER ECR-07-024681	26OCT07	HMR	GJ		

- SPECIFICATIONS: MAGNET WIRE RANGE; #18-#34 .006-.040 DIA [0.16-1.02] mm COPPER. OTHER SIZES MAY BE ACCOMMODATED, CONSULT TYCO ELECTRONICS FOR APPROVAL.
- POCKET RECOMMENDATION: 1601424.
- MAINTAIN THICKNESS FOR THIS LENGTH AND COIN EDGES WITH NO BURRS.
- SPC DATA REQUIRED FOR THESE DIMENSIONS
- TERMINAL APPLICATION TO COMPLY WITH TYCO ELECTRONICS SPECIFICATION 114-13166 FIGURE 5. CONSULT TYCO ELECTRONICS ENGINEERING FOR CARRIER CUTOFF DIMENSIONS.

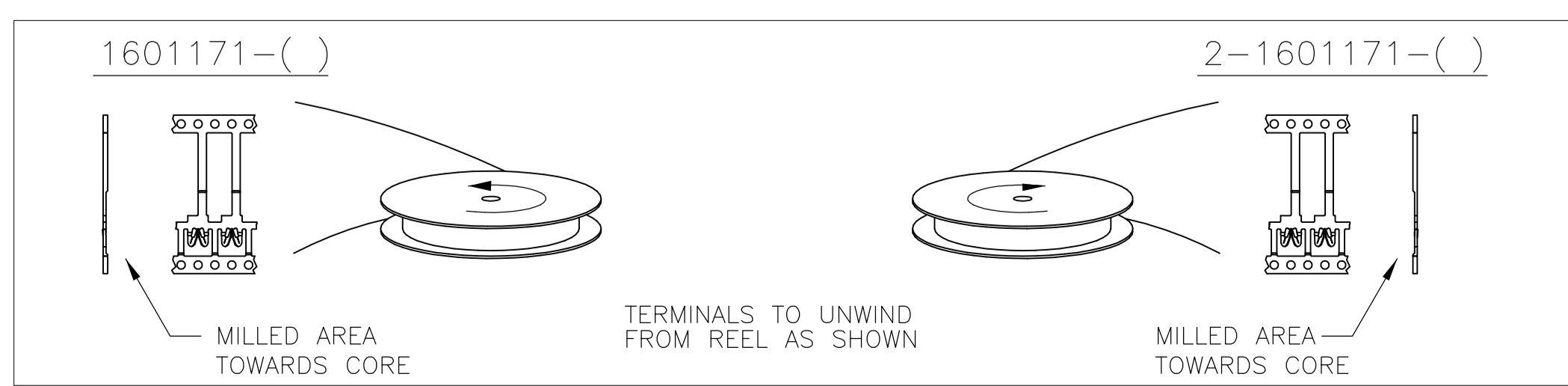
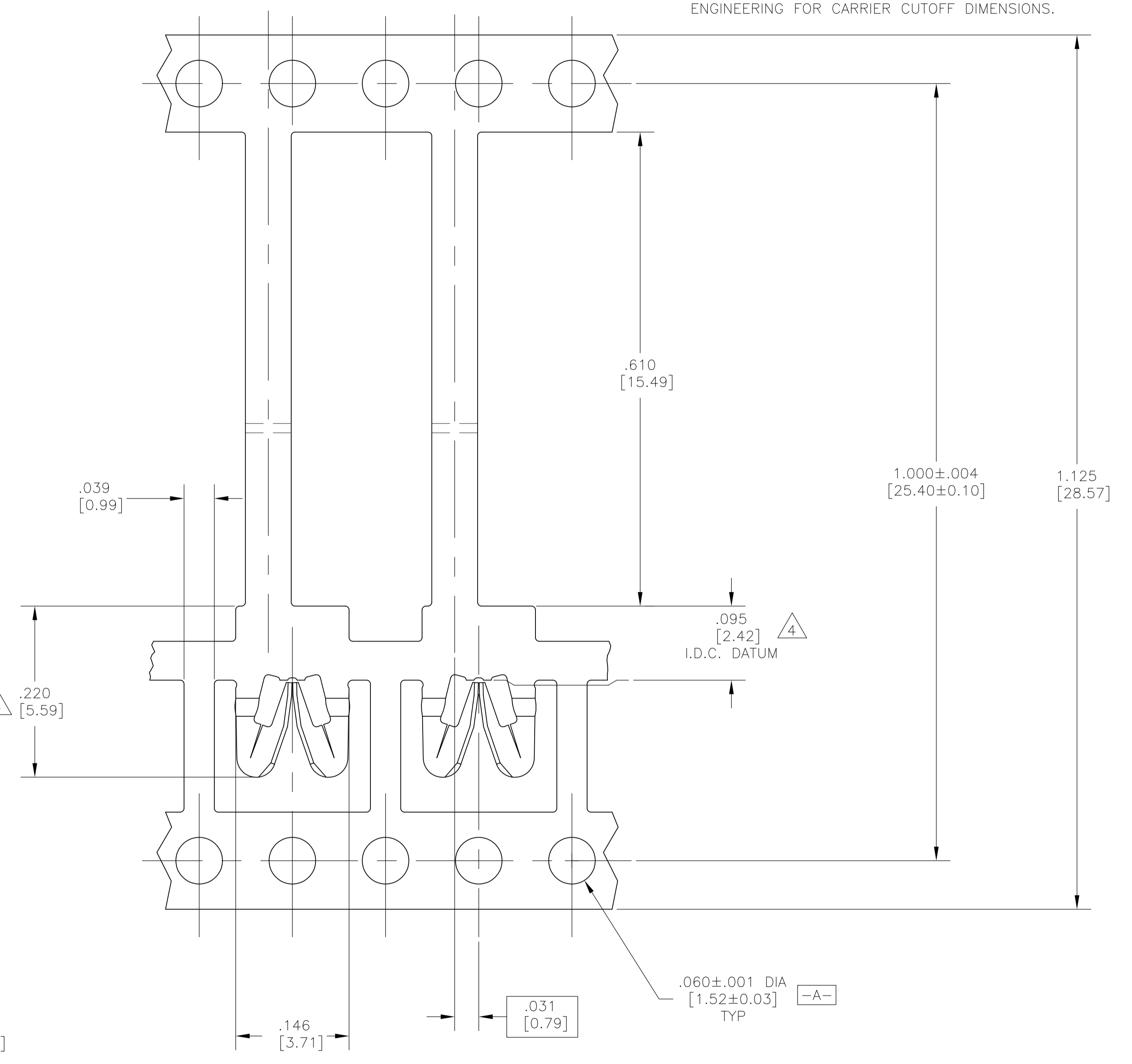
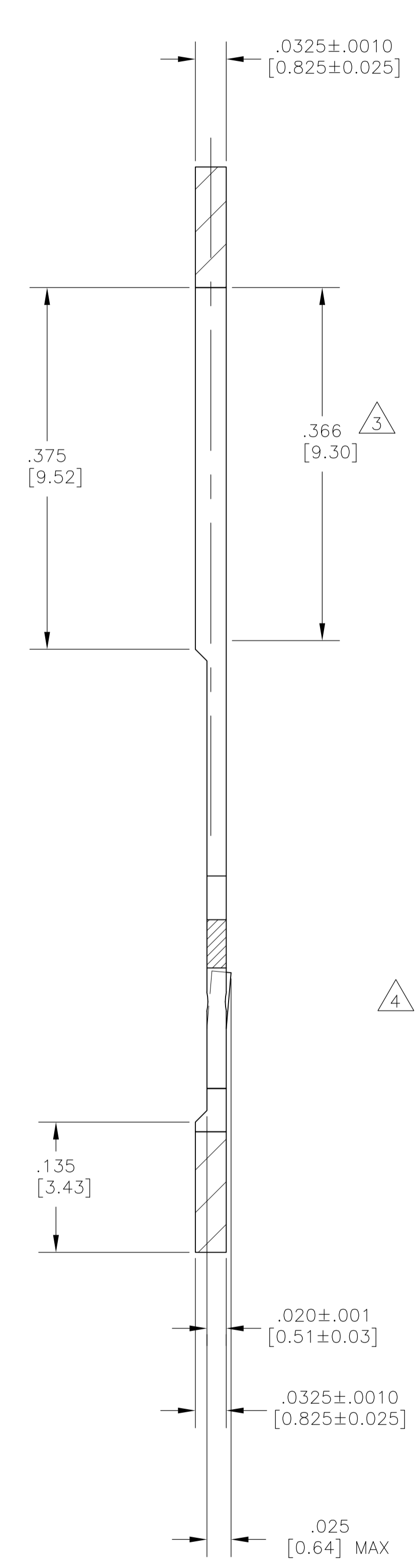
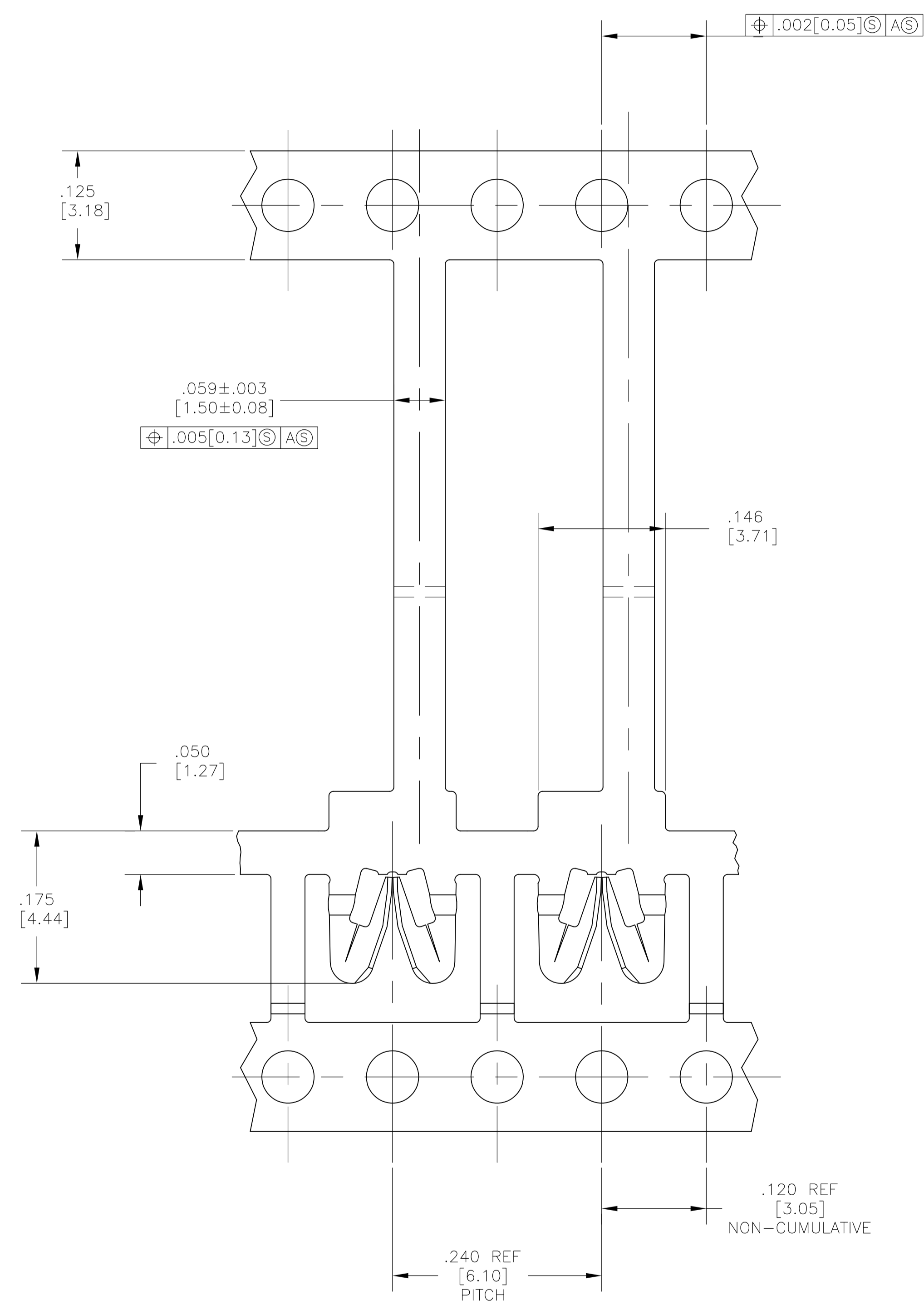

2-1601171-2
PART NUMBER

THIS DRAWING IS A CONTROLLED DOCUMENT.		DIN MICHAEL S. FEJER 22OCT2002	Tyco Electronics Corporation Harrisburg, PA 17105-3608	
DIMENSIONS: INCHES		CHK GENE JACONO 22OCT2002	NAME GENE JACONO	
TOLERANCES UNLESS OTHERWISE SPECIFIED:		APVD GENE JACONO 22OCT2002	PRODUCT SPEC 108-2085	
0 PLC ± -	1 PLC ± -	APPLICATION SPEC 5		
2 PLC ± .01[0.25]	3 PLC ± .005[0.13]	SIZE CAGE CODE DRAWING NO. RESTRICTED TO		
4 PLC ± - # Z	ANGLES ± - # Z	WEIGHT -	A1 00779	1601171
MATERIAL BRASS, FULL HARD	FINISH PRE-TIN PLATE	CUSTOMER DRAWING		SCALE 10:1 SHEET 1 OF 1 REV F1