

Product Specification

2.125 Gb/s RoHS Compliant Short-Wavelength SFP Transceiver

FTLF8519P2xNL

PRODUCT FEATURES

- Up to 2.125 Gb/s bi-directional data links
- Hot-pluggable SFP footprint
- Built-in digital diagnostic functions
- 850nm Oxide VCSEL laser transmitter
- Duplex LC connector
- RoHS Compliant and Lead-Free
- Up to 550m on 50/125µm MMF, 300m on 62.5/125µm MMF
- Metal enclosure, for lower EMI
- Single 3.3V power supply
- Low power dissipation
- Extended operating temperature range: -20°C to 85°C



APPLICATIONS

- 1.25 Gb/s 1000Base-SX Ethernet
- Dual Rate 1.063/2.125 Gb/s Fibre Channel

Finisar's FTLF8519P2xNL Small Form Factor Pluggable (SFP) transceivers are compatible with the Small Form Factor Pluggable Multi-Sourcing Agreement (MSA)¹. They are simultaneously compatible with Gigabit Ethernet as specified in IEEE Std 802.3² and Fibre Channel FC- PI-2 Rev. 10.0³. They are RoHS compliant and lead-free per Directive 2002/95/EC⁴ and Finisar Application Note AN-2038. Digital diagnostics functions are available via the 2-wire serial bus specified in the SFP MSA.

PRODUCT SELECTION

FTLF8519P2xNL

x	W	Wide Extraction Bail
	B	Narrow Extraction Bail

I. Pin Descriptions

Pin	Symbol	Name/Description	Ref.
1	V _{EET}	Transmitter Ground (Common with Receiver Ground)	1
2	T _{FAULT}	Transmitter Fault.	
3	T _{DIS}	Transmitter Disable. Laser output disabled on high or open.	2
4	MOD_DEF(2)	Module Definition 2. Data line for Serial ID.	3
5	MOD_DEF(1)	Module Definition 1. Clock line for Serial ID.	3
6	MOD_DEF(0)	Module Definition 0. Grounded within the module.	3
7	Rate Select	No connection required	
8	LOS	Loss of Signal indication. Logic 0 indicates normal operation.	4
9	V _{EER}	Receiver Ground (Common with Transmitter Ground)	1
10	V _{EER}	Receiver Ground (Common with Transmitter Ground)	1
11	V _{EER}	Receiver Ground (Common with Transmitter Ground)	1
12	RD-	Receiver Inverted DATA out. AC Coupled	
13	RD+	Receiver Non-inverted DATA out. AC Coupled	
14	V _{EER}	Receiver Ground (Common with Transmitter Ground)	1
15	V _{CCR}	Receiver Power Supply	
16	V _{CCT}	Transmitter Power Supply	
17	V _{EET}	Transmitter Ground (Common with Receiver Ground)	1
18	TD+	Transmitter Non-Inverted DATA in. AC Coupled.	
19	TD-	Transmitter Inverted DATA in. AC Coupled.	
20	V _{EET}	Transmitter Ground (Common with Receiver Ground)	1

Notes:

1. Circuit ground is internally isolated from chassis ground.
2. Laser output disabled on T_{DIS} >2.0V or open, enabled on T_{DIS} <0.8V.
3. Should be pulled up with 4.7k – 10kohms on host board to a voltage between 2.0V and 3.6V. MOD_DEF(0) pulls line low to indicate module is plugged in.
4. LOS is open collector output. Should be pulled up with 4.7k – 10kohms on host board to a voltage between 2.0V and 3.6V. Logic 0 indicates normal operation; logic 1 indicates loss of signal.

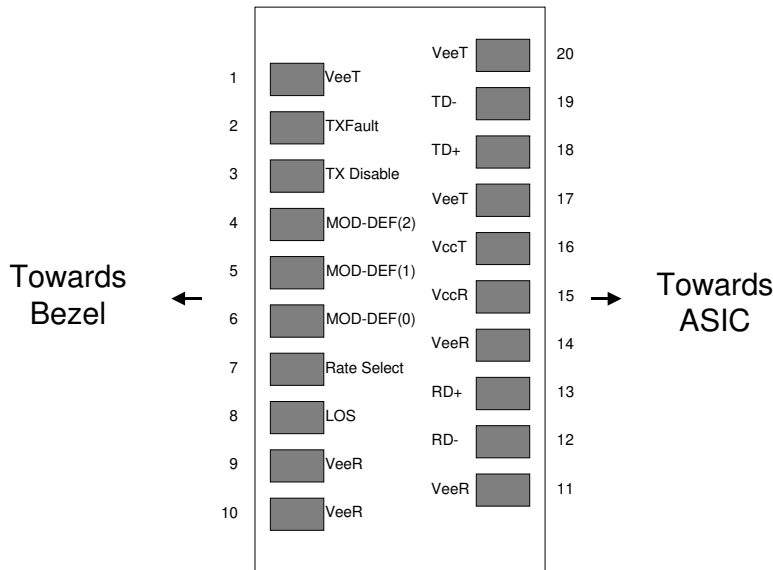

Diagram of Host Board Connector Block Pin Numbers and Names

II. Absolute Maximum Ratings

Parameter	Symbol	Min	Typ	Max	Unit	Ref.
Maximum Supply Voltage	V _{CC}	-0.5		4.0	V	
Storage Temperature	T _S	-40		85	°C	
Case Operating Temperature	T _A	-20		85	°C	
Relative Humidity	RH	0		85	%	1

III. Electrical Characteristics (T_A = -20 to 85 °C, V_{CC} = 3.0 to 3.6 Volts)

Parameter	Symbol	Min	Typ	Max	Unit	Ref.
Supply Voltage	V _{CC}	3.0		3.6	V	
Supply Current	I _{CC}		180	240	mA	
Transmitter						
Input differential impedance	R _{in}		100		Ω	2
Single ended data input swing	V _{in,pp}	250		1200	mV	3
Transmit Disable Voltage	V _D	2		V _{CC}	V	4
Transmit Enable Voltage	V _{EN}	V _{EE}		V _{EE} + 0.8	V	
Receiver						
Single ended data output swing	V _{out,pp}	250	450	550	mV	5
Data output rise time	t _r		90	175	ps	6
Data output fall time	t _f		90	175	ps	6
Mask Margin			45%			
LOS Fault	V _{LOS fault}	2		V _{CCHOST}	V	7
LOS Normal	V _{LOS norm}	V _{EE}		V _{EE} +0.5	V	7
Power Supply Rejection	PSR	100			mVpp	8
Deterministic Jitter Contribution	RX ΔDJ			51.7	ps	9
Total Jitter Contribution	RX ΔTJ		<65	122.4	ps	10

Notes:

1. Non condensing.
2. Connected directly to TX data input pins. AC coupling from pins into laser driver IC.
3. We recommend <600mV for best EMI performance.
4. Or open circuit.
5. Into 100 ohms differential termination.
6. 20 – 80 %
7. LOS is an open collector output. Should be pulled up with 4.7k – 10kohms on the host board. Normal operation is logic 0; loss of signal is logic 1. Maximum pull-up voltage is 5.5V.
8. Receiver sensitivity is compliant with power supply sinusoidal modulation of 20 Hz to 1.5 MHz up to specified value applied through the recommended power supply filtering network.
9. Typical peak-to-peak jitter (=6*RMS width of Jitter).
10. Measured with DJ-free data input signal. In actual application, output DJ will be the sum of input DJ and ΔDJ.
11. If measured with TJ-free data input signal. In actual application, output TJ will be given by:

$$TJ_{OUT} = DJ_{IN} + \Delta DJ + \sqrt{(TJ_{IN} - DJ_{IN})^2 + (\Delta TJ - \Delta DJ)^2}$$

IV. Optical Characteristics (T_{OP} = -20 to 85 °C, V_{CC} = 3.00 to 3.60 Volts)

Parameter	Symbol	Min	Typ	Max	Unit	Ref.
Transmitter						
Output Opt. Pwr: 50 or 62.5 MMF	P _{OUT}	-9		-3	dBm	1
Optical Wavelength	λ	830		860	nm	
Spectral Width	σ			0.85	nm	
Optical Modulation Amplitude @ 2.125 Gb/s	OMA	196			μW	2
Optical Modulation Amplitude @ 1.0625 Gb/s	OMA	156			μW	2
Optical Rise/Fall Time	t _r /t _f		100	150	ps	3
Relative Intensity Noise	RIN			-120	dB/Hz	
Deterministic Jitter Contribution	TX Δ DJ		20	56.5	ps	4
Total Jitter Contribution	TX Δ TJ		<65	119	ps	5
Extinction Ratio @ 1.25 Gb/s	ER	9			dB	
Mask Margin			45%			
Receiver						
Receiver Sensitivity = 1.0625 Gb/s	R _x SENS			-20	dBm	6
Receiver Sensitivity = 2.125 Gb/s	R _x SENS			-18	dBm	6
Receiver Sensitivity = 1.25 Gb/s	R _x SENS			-20	dBm	7
Stressed RX sens. =1.0625 Gb/s		0.055			mW	8
Stressed RX sens. =2.125 Gb/s		0.096			mW	8
Stressed RX sens. =1.25 Gb/s				-13.5	dBm	9
Average Receiver Power	R _x MAX			0	dBm	
Receiver Elec. 3 dB cutoff freq.				1500	MHz	
Optical Center Wavelength	λ _C	770		860	nm	
Optical Return Loss		12			dB	
LOS De-Assert	LOS _D			-20	dBm	
LOS Assert	LOS _A	-30			dBm	
LOS Hysteresis		0.5			dB	

Notes:

- Class 1 Laser Safety per FDA/CDRH, IEC, and EN60825-1 laser safety standards.
- Equivalent extinction ratio specification for Fibre Channel. Allows smaller ER at higher average power.
- Unfiltered, 20-80%. Complies with FC 1x and 2x eye mask when filtered.
- Measured with DJ-free data input signal. In actual application, output DJ will be the sum of input DJ and Δ DJ.
- If measured with TJ-free data input signal. In actual application, output TJ will be given by:

$$TJ_{OUT} = DJ_{IN} + \Delta DJ + \sqrt{(TJ_{IN} - DJ_{IN})^2 + (\Delta TJ - \Delta DJ)^2}$$

- Specifications are for 50 micro-meter or 62.5 micro-meter fiber
- As measured with 9dB extinction ratio.
- Measured with conformance signals defined in FC-PI-2 Rev. 10.0 specifications.
- Measured with conformance signals defined in IEEE 802.3 specifications.

V. General Specifications

Parameter	Symbol	Min	Typ	Max	Units	Ref.
Data Rate	BR		1.062, 1.25, 2.125		Gb/sec	1
Bit Error Rate	BER			10^{-12}		4
Fiber Length on 50/125 μ m MMF	L			550 300	m	2 3
Fiber Length on 62.5/125 μ m MMF	L			300 150	m	2 3

Notes:

1. Gigabit Ethernet and 1x, 2x Fibre Channel compatible, per IEEE 802.3 and FC-PI-2 Rev. 10.0 respectively.
2. At 1.0625 Gb/s Fibre Channel and 1.25 Gb/s Gigabit Ethernet data rates.
3. At 2.125 Gb/s Fibre Channel data rate.
4. 2.125Gb/s with PRBS 2^7-1 .

VI. Environmental Specifications

Finisar 850nm SFP transceivers have an extended operating temperature range from -20°C to $+85^{\circ}\text{C}$ case temperature.

Parameter	Symbol	Min	Typ	Max	Units	Ref.
Case Operating Temperature	T_{op}	-20		85	$^{\circ}\text{C}$	
Storage Temperature	T_{sto}	-40		85	$^{\circ}\text{C}$	

VII. Regulatory Compliance

Finisar transceivers are Class 1 Laser Products and comply with US FDA regulations. These products are certified by TÜV and CSA to meet the Class 1 eye safety requirements of EN (IEC) 60825 and the electrical safety requirements of EN (IEC) 60950. Copies of certificates are available at Finisar Corporation upon request. Copies of the referenced certificates are available at Finisar Corporation upon request.

VIII. Digital Diagnostic Functions

Finisar FTLF8519P2xNL SFP transceivers support the 2-wire serial communication protocol as defined in the SFP MSA¹. It is very closely related to the E²PROM defined in the GBIC standard, with the same electrical specifications.

The standard SFP serial ID provides access to identification information that describes the transceiver's capabilities, standard interfaces, manufacturer, and other information.

Additionally, Finisar SFP transceivers provide a unique enhanced digital diagnostic monitoring interface, which allows real-time access to device operating parameters such as transceiver temperature, laser bias current, transmitted optical power, received optical power and transceiver supply voltage. It also defines a sophisticated system of alarm and warning flags, which alerts end-users when particular operating parameters are outside of a factory set normal range.

The SFP MSA defines a 256-byte memory map in E²PROM that is accessible over a 2-wire serial interface at the 8 bit address 1010000X (A0h). The digital diagnostic monitoring interface makes use of the 8 bit address 1010001X (A2h), so the originally defined serial ID memory map remains unchanged. The interface is identical to, and is thus fully backward compatible with both the GBIC Specification and the SFP Multi Source Agreement. The complete interface is described in Finisar Application Note AN-2030: "Digital Diagnostics Monitoring Interface for SFP Optical Transceivers".

The operating and diagnostics information is monitored and reported by a Digital Diagnostics Transceiver Controller (DDTC) inside the transceiver, which is accessed through a 2-wire serial interface. When the serial protocol is activated, the serial clock signal (SCL, Mod Def 1) is generated by the host. The positive edge clocks data into the SFP transceiver into those segments of the E²PROM that are not write-protected. The negative edge clocks data from the SFP transceiver. The serial data signal (SDA, Mod Def 2) is bi-directional for serial data transfer. The host uses SDA in conjunction with SCL to mark the start and end of serial protocol activation. The memories are organized as a series of 8-bit data words that can be addressed individually or sequentially.

For more information, please see the SFP MSA documentation^{1,5} or Finisar Application Note AN-2030.

Please note that evaluation board FDB-1018 is available with Finisar ModDEMO software that allows simple to use communication over the 2-wire serial interface.

IX. Digital Diagnostic Specifications

FTLF8519P2xNL transceivers can be used in host systems that require either internally or externally calibrated digital diagnostics.

Parameter	Symbol	Min	Typ	Max	Units	Ref.
Accuracy						
Internally measured transceiver temperature	DD _{Temperature}			3	°C	
Internally measured transceiver supply voltage	DD _{Voltage}			100	mV	
Measured TX bias current	DD _{Bias}			10	%	1
Measured TX output power	DD _{Tx-Power}			2	dB	
Measured RX received average optical power	DD _{Rx-Power}			2	dB	
Dynamic Range for Rated Accuracy						
Internally measured transceiver temperature	DD _{Temperature}	-20		85	°C	
Internally measured transceiver supply voltage	DD _{Voltage}	3.0		3.6	V	
Measured TX bias current	DD _{Bias}	0		20	mA	
Measured TX output power	DD _{Tx-Power}	-9		-3	dBm	
Measured RX received average optical power	DD _{Rx-Power}	-20		0	dBm	
Max Reporting Range						
Internally measured transceiver temperature	DD _{Temperature}	-40		125	°C	
Internally measured transceiver supply voltage	DD _{Voltage}	2.8		4.0	V	
Measured TX bias current	DD _{Bias}	0		20	mA	
Measured TX output power	DD _{Tx-Power}	-10		-3	dBm	
Measured RX received average optical power	DD _{Rx-Power}	-22		0	dBm	

Notes:

1. Accuracy of Measured Tx Bias Current is 10% of the actual Bias Current from the laser driver to the laser.

X. Mechanical Specifications

Finisar’s Small Form Factor Pluggable (SFP) transceivers are compatible with the dimensions defined by the SFP Multi-Sourcing Agreement (MSA).

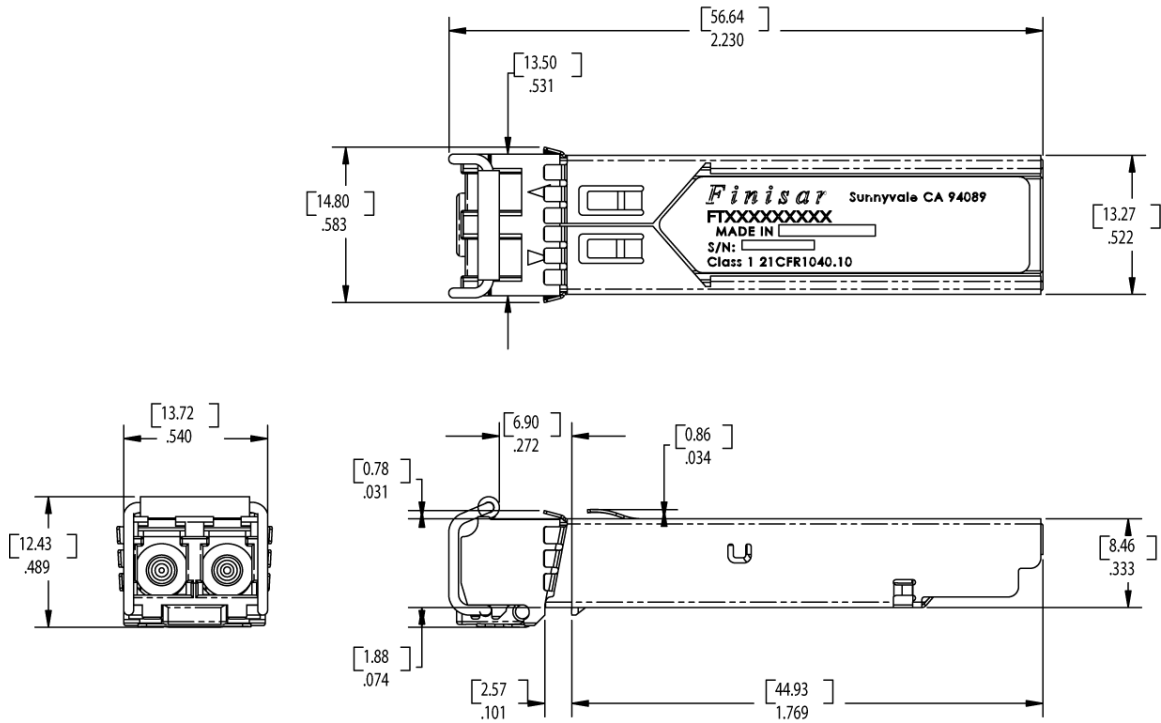

FTLF8519P2BNL

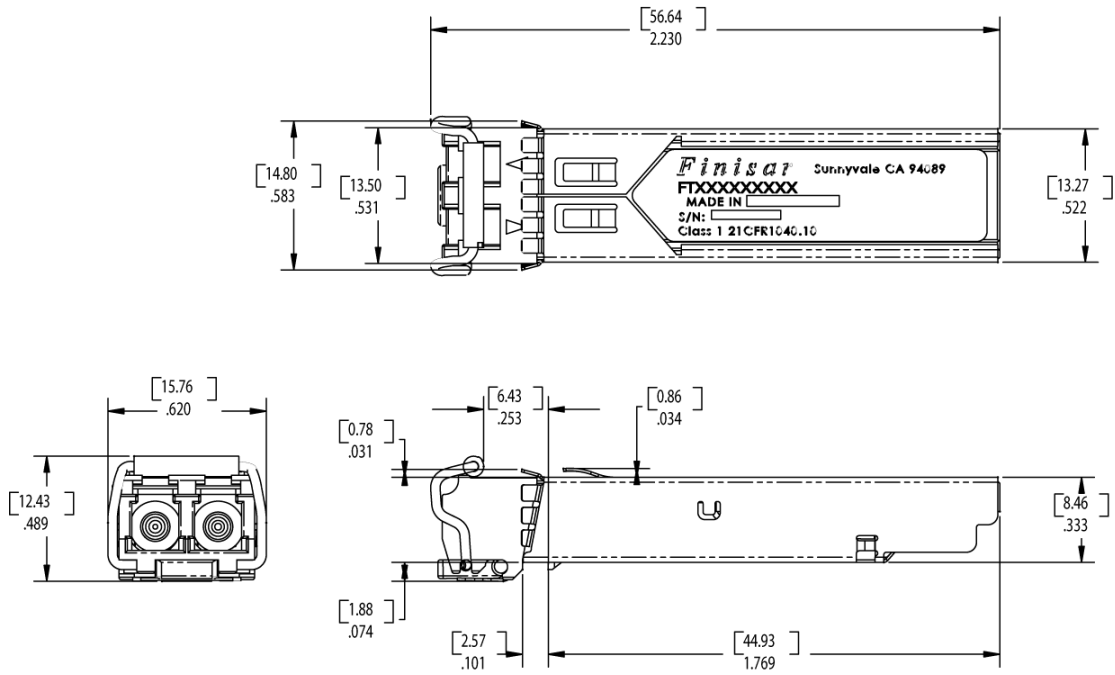

FTLF8519P2WNL

XI. PCB Layout and Bezel Recommendations

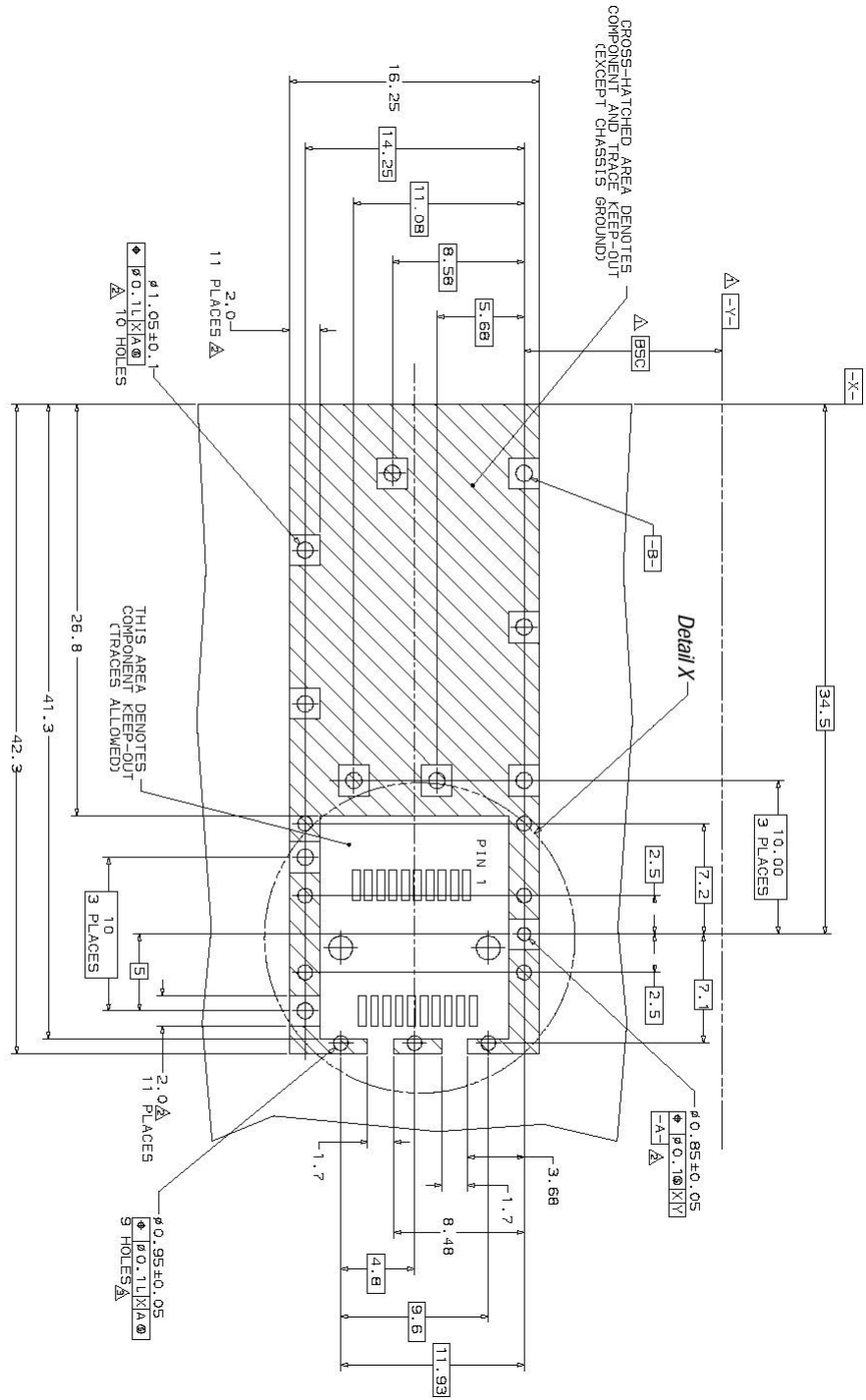

- △ Datum and Basic Dimension Established by Customer
- △ Rads and Vias are Chassis Ground, 11 Places
- △ Through Holes are Unplated

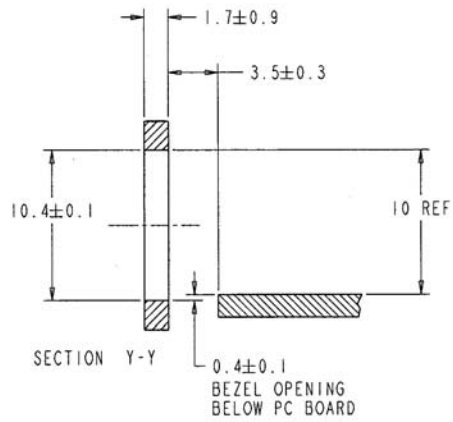
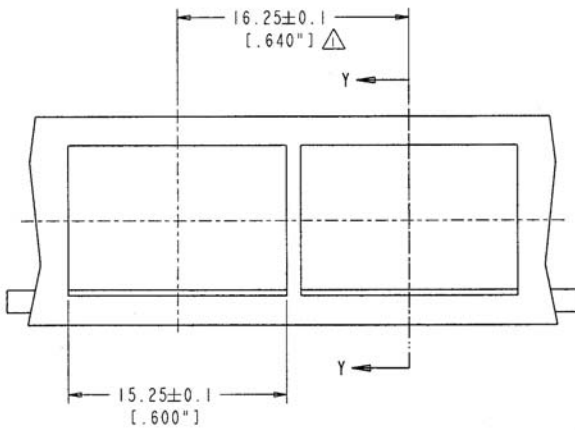
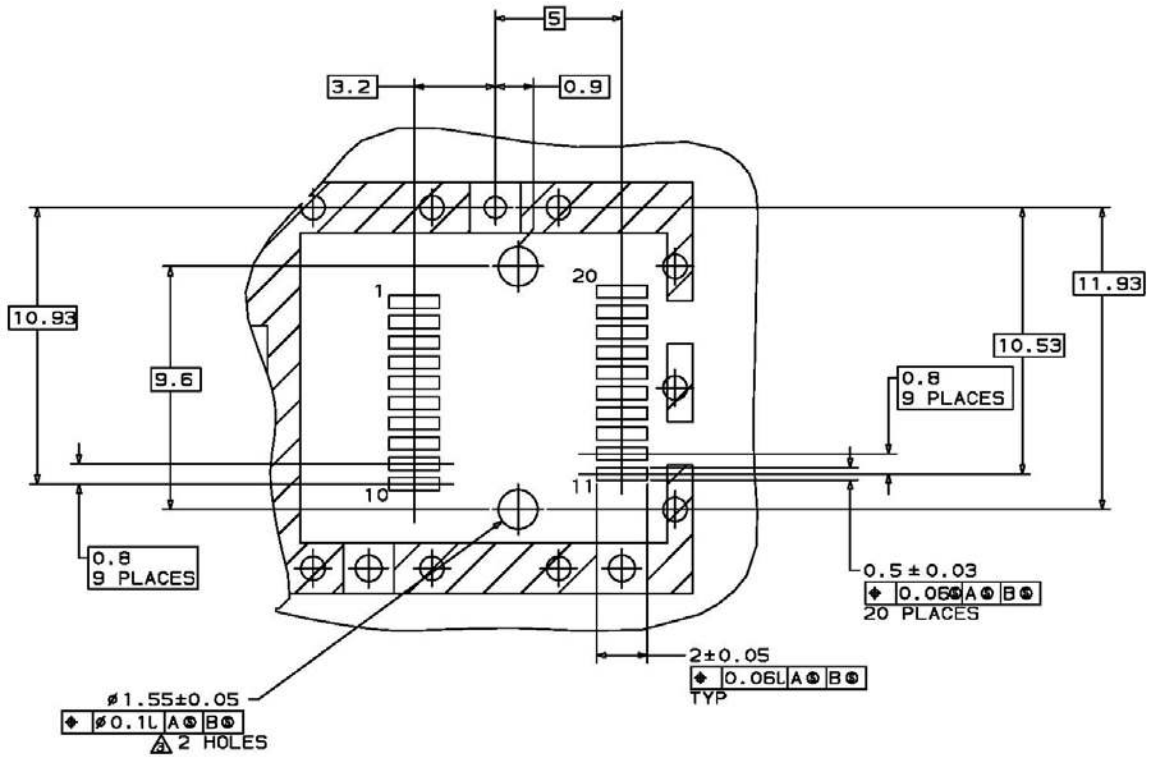

NOTES:

Δ MINIMUM PITCH ILLUSTRATED, ENGLISH DIMENSIONS ARE FOR REFERENCE ONLY

- 2. NOT RECOMMENDED FOR PCI EXPANSION CARD APPLICATIONS

XII. References

1. Small Form Factor Pluggable (SFP) Transceiver Multi-source Agreement (MSA). September 14, 2000.
2. IEEE Std 802.3, 2002 Edition, Clause 38, PMD Type 1000BASE-SX. IEEE Standards Department, 2002.
3. “Fibre Channel Draft Physical Interface Specification (FC-PI-2 Rev. 10.0)”. American National Standard for Information Systems.
4. Directive 2002/95/EC of the European Council Parliament and of the Council, “on the restriction of the use of certain hazardous substances in electrical and electronic equipment.” January 27, 2003.
5. “Digital Diagnostics Monitoring Interface for Optical Transceivers”. SFF Document Number SFF-8472, Revision 9.3.

XIII. For More Information

Finisar Corporation
1389 Moffett Park Drive
Sunnyvale, CA 94089-1133
Tel. 1-408-548-1000
Fax 1-408-541-6138
sales@finisar.com
www.finisar.com