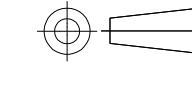

THIS DRAWING IS A CONTROLLED DOCUMENT.		DIN	T. HOFFMAN	2/24/93	TE Connectivity
DIMENSIONS: mm [INCHES]		CHK	G.E. SKIPPER	4/27/93	
TOLERANCES UNLESS OTHERWISE SPECIFIED:		APVD			NAME
0 PLC	± -	PRODUCT SPEC		HDI, 4 ROW, RECEPTACLE ASSEMBLY, 4.57 [.180] LONG SOLDER TAILS, 0.00127 [.000050] GOLD PLATE	
1 PLC	± -	APPLICATION SPEC		SIZE	
2 PLC	± -	MATERIAL		CAGE CODE DRAWING NO. RESTRICTED TO	
3 PLC	± 0.13 [.005]	FINISH		WEIGHT	
4 PLC	± -	CUSTOMER DRAWING		SCALE 4:1 SHEET 1 OF 2 REV C1	
ANGLES	± -	SCALE		SHEET	
		SCALE		SHEET	
		SCALE		SHEET	

LOC		DIST		REVISIONS				
AD	25	NO	DATE	DESCRIPTION	DATE	BY	APPROV	
-	-	-	-	SEE SHEET 1	-	-	-	

- 1 HOUSING MATERIAL: THERMOPLASTIC, COLOR-NATURAL.
- 2 CONTACT MATERIAL: BERYLLIUM COPPER.
- 3 CONTACT FINISH: .00127-.00254 [.000050-.000100] NICKEL UNDERPLATE ALL OVER; .00127 [.000050] GOLD PLATE IN CONTACT AREA, TIN-LEAD PLATED SOLDER TAILS.
- 4 SOLDER TAILS MUST FIT HOLE PATTERN AS SHOWN ON THE RECOMMENDED P.C. BOARD LAYOUT.
- 5 DIMENSIONS IN BRACKETS ARE IN INCHES.
- 6 HOUSINGS WITH CENTER MOUNTING IS RECOMMENDED FOR ASSEMBLIES HAVING 75 CONTACTS PER ROW OR MORE.
- 7 MARKED EVERY TENTH POST POSITION.
- 8 MARKED ROW D AND FIRST-LAST POSITION IDENTIFICATION.
- 9 TOTAL NUMBER OF POSITIONS PER ROW \*.
- 10 MIL-C-55302 A AND B INSPECTION REQUIRED.

144.78 [5.700]	57	147.93 [5.824]	158.75 [6.250]	166.37 [6.550]	232	-	1-533938-4
111.76 [4.400]	44	114.91 [4.524]	125.73 [4.950]	133.35 [5.250]	180	-	1-533938-3
86.36 [3.400]	34	89.51 [3.524]	100.33 [3.950]	107.95 [4.250]	140	-	1-533938-2
73.66 [2.900]	29	76.81 [3.024]	87.63 [3.450]	95.25 [3.750]	120	-	1-533938-1
187.96 [7.400]	74	191.11 [7.524]	201.93 [7.950]	209.55 [8.250]	300	M55302/180-49	1-533938-0
175.26 [6.900]	69	178.41 [7.024]	189.23 [7.450]	196.85 [7.750]	280	M55302/180-45	533938-9
167.64 [6.600]	66	170.79 [6.724]	181.61 [7.150]	189.23 [7.450]	268	M55302/180-41	533938-8
162.56 [6.400]	64	165.71 [6.524]	176.53 [6.950]	184.15 [7.250]	260	M55302/180-37	533938-7
149.86 [5.900]	59	153.01 [6.024]	163.83 [6.450]	171.45 [6.750]	240	M55302/180-33	533938-6
137.16 [5.400]	54	140.31 [5.524]	151.13 [5.950]	158.75 [6.250]	220	M55302/180-29	533938-5
124.46 [4.900]	49	127.61 [5.024]	138.43 [5.450]	146.05 [5.750]	200	M55302/180-25	533938-4
99.06 [3.900]	39	102.21 [4.024]	113.03 [4.450]	120.65 [4.750]	160	M55302/180-17	533938-3
78.74 [3.100]	31	81.89 [3.224]	92.71 [3.650]	100.33 [3.950]	128	M55302/180-09	533938-2
60.96 [2.400]	24	64.11 [2.524]	74.93 [2.950]	82.55 [3.250]	100	M55302/180-01	533938-1
E	D	C	B	A	POSN	MILITARY	AMP
						PART NUMBERS	

THIS DRAWING IS A CONTROLLED DOCUMENT.		DIN T. HOFFMAN 2/24/93	 TE Connectivity	
DIMENSIONS: mm [INCHES]		CHK G.E. SKIPPER 4/27/93	NAME	
TOLERANCES UNLESS OTHERWISE SPECIFIED: 0 PLG ± - 1 PLG ± - 2 PLG ± - 3 PLG ± 0.13 [.005] 4 PLG ± - ANGLES ± -		APVD	PRODUCT SPEC	
		APVD	APPLICATION SPEC	
MATERIAL	FINISH	WEIGHT	SIZE	RESTRICTED TO
1/2	3	-	A1 00779 533938	-
CUSTOMER DRAWING			SCALE 4:1	SHEET 2 OF 2