

MINI-DC-UPS/12DC/4

Uninterruptible power supply with integrated power supply unit

INTERFACE

Data sheet
104211_en_00

© PHOENIX CONTACT - 01/2010



1 Description

The MINI-DC-UPS provide an uninterruptible DC voltage both in case of AC power supply network and in the event of mains interferences. The wide-range input allows input voltages from 85 V AC to 264 V AC; 4 A is provided at the output with a regulated and adjustable output voltage from 10 V DC to 16 V DC. The rechargeable battery module supplies an output voltage from 13.8 V DC to 9.6 V DC in buffer mode. A 1.6 Ah or a 2.6 Ah rechargeable battery module is optionally used depending on the required buffer time. The buffer time varies depending on the load current.

Features

- Easy assembly on the DIN rail or panel
- Quick startup with LED function monitoring
- Buffer time of 0.5 to 30 minutes or permanently settable
- Can be used worldwide in all industrial sectors due to a wide-range input and an international approval package
- Battery management for optimized, temperature-compensated charging with simultaneous increase of battery life
- High operating safety due to long mains buffering under full load and high MTBF (> 500,000 h)



DANGER OF EXPLOSION!

Only remove equipment when it is disconnected and not in the potentially explosive area.



The device contains dangerous live elements and high levels of stored energy. Never carry out work when the power is turned on.



Make sure you always use the latest documentation. It can be downloaded from the product at www.phoenixcontact.net/catalog.

2 Table of contents

1	Description	1
	Features.....	1
2	Table of contents.....	2
3	Ordering data	3
4	Technical data	3
5	Structure.....	7
6	Block diagram	8
7	Safety and warning notes	8
8	Installation	8
9	Installation position.....	9
10	Mounting on DIN rails	9
	Assembly	9
	Removing.....	9
11	Connection, network forms 100...240 V AC networks	10
12	Input	10
13	Output	11
	Signaling outputs	11
14	Signaling	11
15	Rechargeable battery module	12
16	Remote shutdown ("Remote").....	12
	Remote shutdown inactive.....	12
	Remote shutdown active.....	12
17	Function	13
	Setting the output voltage	13
	Buffer time setting	13

3 Ordering data

Description	Type	Order No.	Pcs. / Pkt.
Uninterruptible power supply with integrated power supply unit, 4 A, in combination with MINI-BAT/12/DC 1.6 Ah or 2.6 Ah	MINI-DC-UPS/12DC/4	2866598	1



The MINI-DC-UPS/12DC/4 is supplied without battery module. Please order a battery module separately (see accessories).

Accessories	Type	Order No.	Pcs. / Pkt.
Rechargeable battery module, 12 V DC, 1.6 Ah, for use with DC-UPS/4A	MINI-BAT/12DC/1.6AH	2866572	1
Rechargeable battery module, 12 V DC, 2,6 Ah, for use with DC-UPS/4A	MINI-BAT/12DC/2.6AH	2866569	1

4 Technical data

Input data	
Input nominal voltage range	100 V AC ... 240 V AC
AC input voltage range	85 V AC ... 264 V AC
DC input voltage range	100 V DC ... 350 V DC (UL508: 100...250 V DC)
Buffer period	(Depending on the storage medium, e.g. 20 min / 4A)
Current consumption	Approx. 0.5 A / 0.65 A (for 230 V AC) Approx. 1.15 A / 1.35 A (for 120 V AC)
Inrush current limitation	< 34 A
I^2t	< 1.1 A ² s
Power failure bypass	(refer to the diagram)
Typical response time	100 ms
Power factor (cos phi)	Approx. 0.5
Protective circuitry	Varistor
Input fuse, integrated	3.15 A (slow-blow, internal)
Recommended backup fuse for mains protection	6 A (characteristic B) 10 A (characteristic B) 16 A (characteristic B)
Output data	
Nominal output voltage	12 V DC (AC input voltage available: 10 to 16 V DC, AC input voltage not available: 13.8 to 9.6 V DC)
Setting range of the output voltage	10 V DC ... 16 V DC (AC input voltage available, AC input voltage not available: Output voltage depending on the battery voltage: 13.8 V DC ... 9.6 V DC)
Output current	4 A
Derating	From +60°C to 70°C: 2.5% per Kelvin
Output current limit	max. 7 A
Charge current	max. 1 A
Max. capacitive load	Unlimited
Control deviation	< 1 % (change in load, static 10% ... 90%)
Efficiency	> 82 %
Ascent time	< 100 ms
Residual ripple	< 50 mV _{pp}
Peak switching voltages	< 100 mV _{pp}
Connection in parallel	No
Surge protection against internal surge voltages	Yes, < 35 V DC
Resistance to reverse feed	35 V DC

Power consumption

Maximum power dissipation idling	3.8 W
Power loss nominal load max.	10.5 W
Power dissipation battery operation	2.9 W

Alarm

Output description	Relay output
Voltage	≤ 12 V
Status display	LED red / Malfunction/alarm: LED permanently lit

Battery charge

Output description	Relay output
Voltage	≤ 12 V
Status display	LED yellow, flashing / Battery charge/battery is being charged: LED flashing

Battery mode

Output description	Relay output
Voltage	≤ 12 V
Status display	Yellow LED / Battery mode/buffer mode: LED permanently lit

General data

Insulation voltage input/output	2 kV (routine test) 4 kV (type test)
Degree of protection	IP20
Class of protection	II (in an enclosed control cabinet)
MTBF	> 500 000 h in acc. with IEC 61709 (SN 29500)
Type of housing	Polyamide PA, color: green
Dimensions W / H / D (state of delivery)	67.5 mm / 99 mm / 115 mm
Weight	0.45 kg

Ambient conditions

Ambient temperature (operation)	-25 °C ... 70 °C (> 60 °C derating)
Ambient temperature (storage/transport)	-40 °C ... 80 °C
Max. permissible relative humidity (operation)	95 % (at 25 °C, no condensation)
Vibration (operation)	< 15 Hz, amplitude ±2.5 mm in acc. with IEC 60068-2-6 15 Hz ... 150 Hz, 2.3g, 90 min.
Shock	30g in all directions in acc. with IEC 60068-2-27
Pollution degree in acc. with EN 50178	2
Climatic class	3K3 (in acc. with EN 60721)

Standards

Electrical Equipment for Machinery	EN 60204
Safety transformers for power supply units	EN 61558-2-17
Electrical safety (of information technology equipment)	EN 60950/VDE 0805 (SELV) EN 61558-2-17
Electronic equipment for use in electrical power installations	EN 50178/VDE 0160 (PELV)
SELV	EN 60950 (SELV) EN 60204 (PELV)
Safe isolation	DIN VDE 0100-410 DIN VDE 0106-1010
Protection against electric shock, basic requirements for safe isolation in electrical equipment	DIN VDE 0106-101

Approvals

UL approvals	UL Listed UL 508 UL/C-UL Recognized UL 60950
--------------	---

Conformance with EMC guideline 2004/108/EC and for low-voltage guideline 2006/95/EC

Noise immunity according to EN 61000-6-2

Electrostatic discharge	EN 61000-4-2
	Housing Level 3
	Contact discharge 6 kV
	Discharge in air 8 kV
	Comments Criterion B
Electromagnetic HF field	EN 61000-4-3
	Housing Level 3
	Frequency range 80 MHz ... 2 GHz
	Field intensity 10 V/m
	Comments Criterion A
Fast transients (burst)	EN 61000-4-4
	Input 4 kV (level 4 - asymmetrical: conductor to ground)
	Output 2 kV (level 3 - asymmetrical: conductor to ground)
	Signal 1 kV (level 2 - asymmetrical: conductor to ground)
	Comments Criterion B
Surge current loads (surge)	EN 61000-4-5
	Input 4 kV (level 4 - asymmetrical: conductor to ground) 2 kV (level 4 - symmetrical: conductor to conductor)
	Output 2 kV (Level 3 - asymmetrical) 1 kV (Level 3 - symmetrical)
	Signal 2 kV (Level 3 - asymmetrical) 1 kV (Level 3 - symmetrical)
	Comments Criterion B
Conducted interference	EN 61000-4-6
	Input/Output/Signal Level 3
	Frequency range 10 kHz ... 80 MHz
	Voltage 10 V
	Comments Criterion A

Conformance with EMC guideline 2004/108/EC and for low-voltage guideline 2006/95/EC (Continued)

Noise immunity according to EN 61000-6-2

Voltage dips	EN 61000-4-11
	Input (mains buffering > 20 ms)
	Comments Criterion B

Emitted interference in acc. with EN 61000-6-3

Radio interference voltage in acc. with EN 55011	EN 55011 (EN 55022) Class B, area of application: Industry and residential
Emitted radio interference in acc. with EN 55011	EN 55011 (EN 55022) Class B, area of application: Industry and residential

5 Structure

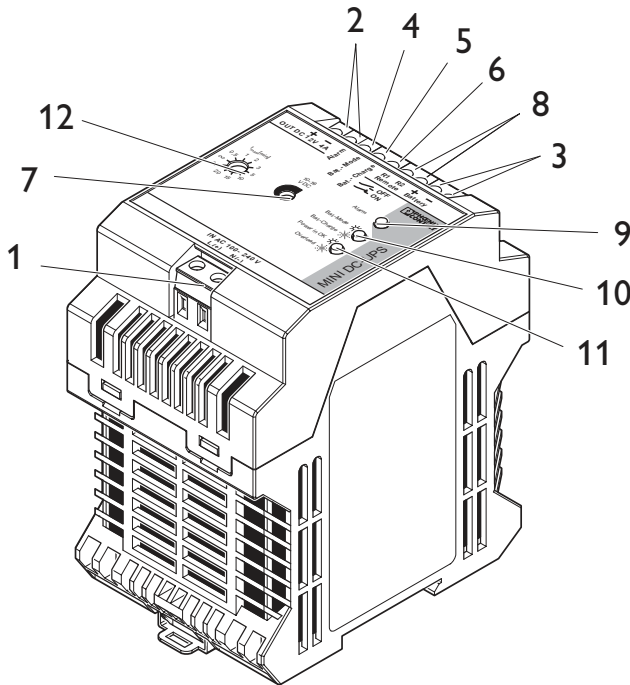

- 1 AC input
- 2 DC output
- 3 Rechargeable battery connection
- 4 Active relay output: Alarm
- 5 Active relay output: Battery Mode
- 6 Active relay output: Battery Charge
- 7 Potentiometer 10 V DC ... 16 V DC
- 8 Remote shutdown (R1, R2)
- 9 Red control lamp: Alarm
- 10 Yellow control lamp: Battery Mode/Battery Charge
- 11 Green control lamp: Power In OK/Overload
- 12 Buffer time setting 0.5 min ... 30 min and permanently

	[mm ²]		AWG	[Nm] Torque
	solid	stranded		
Input	0.2 - 2.5	0.2 - 2.5	24 - 12	0.5 - 0.6
Output	0.2 - 2.5	0.2 - 2.5	24 - 12	0.5 - 0.6
Signal	0.2 - 2.5	0.2 - 2.5	24 - 12	0.5 - 0.6

Input data

Input nominal voltage range	100 V AC ... 240 V AC
AC input voltage range	85 V AC ... 264 V AC
DC input voltage range	100 V DC ... 350 V DC (UL508: 100...250 V DC)
Input fuse, integrated	3.15 A (slow-blow, internal)
Recommended backup fuse for mains protection	6 A (characteristic B) 10 A (characteristic B) 16 A (characteristic B)
Type of connection	Pluggable COMBICON screw connections,
Stripping length	8 mm

Output data

Nominal output voltage	12 V DC (AC input voltage available: 10 to 16 V DC, AC input voltage not available: 13.8 to 9.6 V DC)
Setting range of the output voltage	10 V DC ... 16 V DC (AC input voltage available, AC input voltage not available: Output voltage depending on the battery voltage: 13.8 V DC ... 9.6 V DC)
Output current	4 A
Type of connection	Pluggable COMBICON screw connections,
Stripping length	8 mm

6 Block diagram

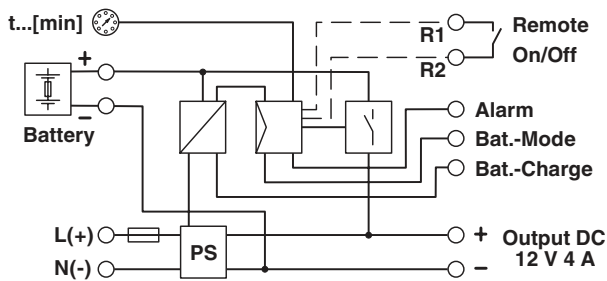

7 Safety and warning notes



DANGER

The device contains dangerous live elements and high levels of stored energy. Never carry out work when the power is turned on. Depending on the ambient temperature and the load, the housing can become very hot!



WARNING

Before startup please ensure:

The mains connection has been carried out by a competent person and protection against electric shock is guaranteed!

The device can be disconnected outside the power supply unit in accordance with the regulations as in EN 60950 (e.g. through primary side line protection)!

All feed lines are sufficiently protected and dimensioned!

All output lines are dimensioned according to the maximum output current of the device or separately protected!

Sufficient convection is guaranteed!



CAUTION

The power supply units are built-in devices. The device may only be installed and put into operation by qualified personnel. The corresponding national regulations must be observed.

8 Installation



In order for the device to function in the manner intended, it is not necessary to observe any minimum spacing to other devices.



The power supply unit can be snapped onto all DIN rails in acc. with EN 60715. They must be mounted horizontally (connecting terminal blocks top and bottom).

9 Installation position

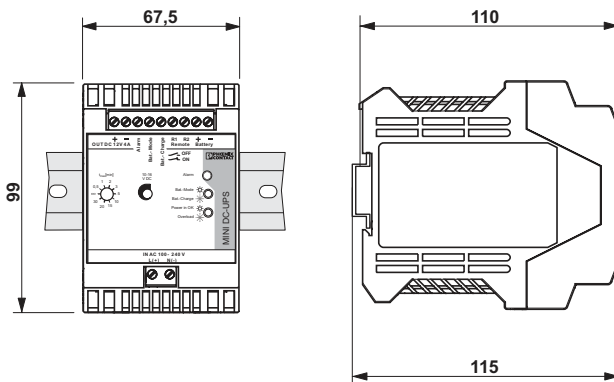

10 Mounting on DIN rails

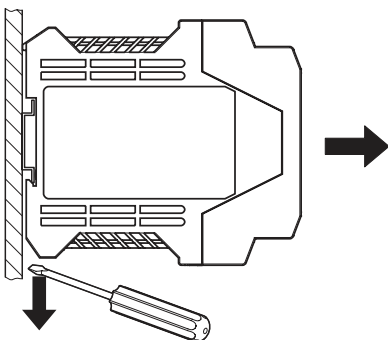
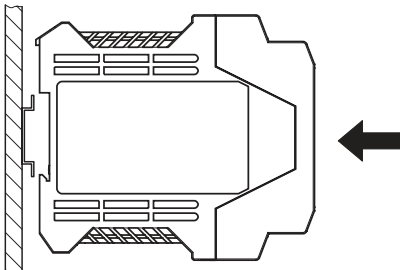

Assembly

To mount on a DIN rail, snap the device straight onto the DIN rail.

Removing

To remove from the DIN rail, press the base latch outward and pull the device off of the DIN rail.

11 Connection, network forms 100...240 V AC networks

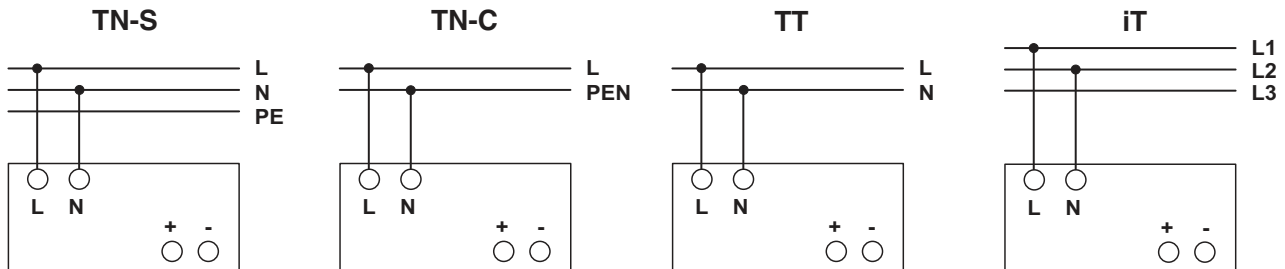

The 100...240 V AC connection is made using the L and N screw connections.

The device can be connected to 1-phase AC networks or to two of the phase conductors of three-phase systems (TN, TT or IT networks in acc. with VDE 0100-300/IEC 60364-3) with nominal voltages of 100 V AC ...240 V AC.



For operation on two of the phase conductors of a three-phase system, an isolating facility for all poles must be provided.

12 Input

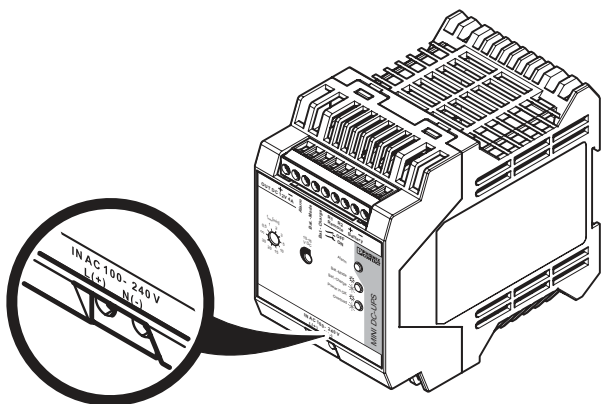

CAUTION

If an internal fuse is triggered, there is a device malfunction. In this case, the device must be inspected in the factory.

The 100 ... 240 V AC connection is established using the L and N screw connections.

The device must be installed in acc. with the regulations as in EN 60950. It must be possible to disconnect the device using a suitable isolating facility outside the power supply.

The primary side line protection, for example, is suitable. For device protection, there is an internal fuse. Additional device protection is not necessary.

13 Output

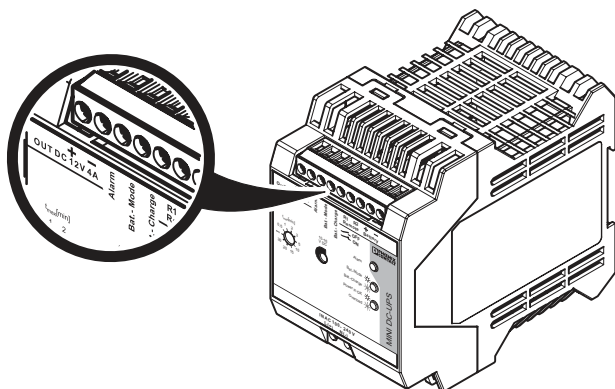

CAUTION

Make sure that all output lines are dimensioned according to the maximum output current or are separately protected. The cables on the secondary side must have sufficiently large cross sections in order to keep the voltage drops on the lines as low as possible.

Signaling outputs

The connection is established through the "OUT DC 12 V, +, -" screw connections. The set output voltage is 12 V DC at the time of delivery. The output voltage from 10 V DC to 16 V DC can be set on the potentiometer.

Signal outputs are connected using "Alarm", "Bat.-Mode" and "Bat.-Charge" terminal blocks. Three control lamps and three active switching outputs are provided for function monitoring.

14 Signaling

State	Power In OK	Battery mode/ Battery charge	Alarm
Supply voltage OK, rechargeable battery is being charged	LED on	LED is flashing; Battery mode output: 0 V, Battery charge: 12 V	LED off; output: 0 V
Supply voltage OK, rechargeable battery charged (normal mode)	LED on	LED off; Battery mode / Battery charge output: 0 V	LED off; output: 0 V
Buffer mode	LED off	LED on; Battery mode output: 12 V, Battery charge: 0 V	LED off; output: 0 V
Battery discharged, UBAT < 10.2 V DC	LED off	LED on; Battery mode / Battery charge output: 0 V	LED on; output: 12 V
Rechargeable battery test negative	LED on	LED off; Battery mode / Battery charge output: 0 V	LED on; output: 12 V
Buffer time over and remote shutdown activated	LED off	LED off; Battery mode / Battery charge output: 0 V	LED off; output: 0 V

15 Rechargeable battery module

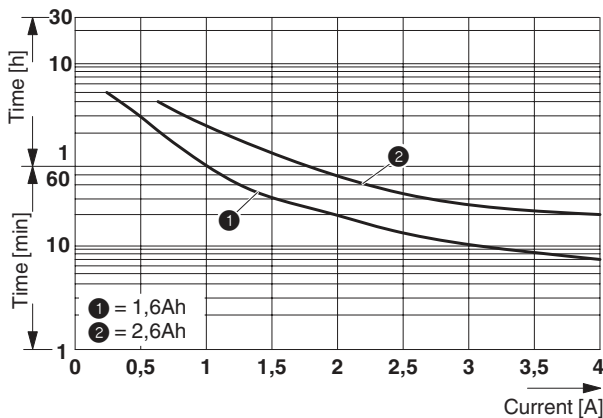

The rechargeable battery module is connected to the power supply unit through the "Battery +" and the "Battery -" terminal blocks. The fuse of the rechargeable battery module must be removed when installing or replacing the module.

We recommend to use the following battery modules:

1. MINI-BAT 12DC/1.6Ah (Order No. 2866572)
2. MINI-BAT 12DC/2.6Ah (Order No. 2866569)

The buffer mode might be terminated after the preset time or due to an external shutdown. If the device is to be switched off after a certain period, the time for it is set using the selector switch at the front of the device. The device can be switched on in the buffer mode again after reconnecting the power supply.

16 Remote shutdown ("Remote")

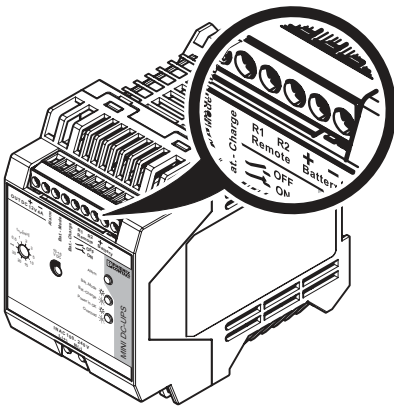

The device has a remote shutdown with a UPS function for deliberate shutdown. Remote shutdown must be deactivated for the device to switch over to the buffer mode in the event of a supply voltage failure.

Remote shutdown inactive

The "Remote shutdown R1" and "Remote shutdown R2" terminal points are short-circuited (e.g., with a plug-in bridge) OR 12 V DC is present at the "Remote shutdown R2" terminal point.

- The power supply unit switches over to the buffer mode in the event of a supply voltage failure.

Remote shutdown active

The "Remote shutdown R1" and "Remote shutdown R2" terminal points are not short-circuited (e.g., with a plug-in bridge) OR 0 V is present at the "Remote shutdown R2" terminal point.

- All LEDs are off.
- The power supply does not switch over to the buffer mode in the event of a supply voltage failure; the device switches off. The rechargeable battery module is charged when the supply voltage is reconnected, but the device remains switched off until the remote shutdown is activated.
- The connected consumers are fed as long as the supply voltage is available.

17 Function

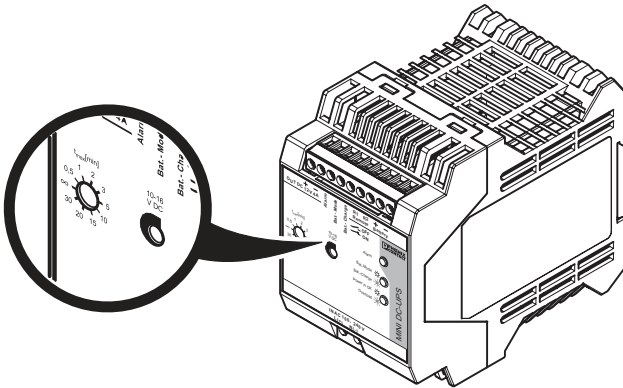

Setting the output voltage

In the normal mode, the output voltage of the device conforms to the setting on the potentiometer (10 V DC ... 16 V DC). If the supply voltage fails, the buffer mode is activated without any interruption and the output voltage is supplied by the rechargeable battery module. The output voltage is now directly dependent on the battery voltage and is $U_{\text{BAT}} - 0.5 \text{ V}$. An alarm signal is triggered if the output voltage drops below 10.2 V in the buffer mode. If the output voltage drops to 9.6 V due to a completely discharged rechargeable battery module, the device switches off and remains switched off. The device switches on automatically only after reconnecting the power supply. The device is electronically protected against short-circuits and no-load operation.

Buffer time setting

The buffer mode might be terminated after the preset time or due to an external shutdown. If the device is to be shut down after a specific time has elapsed, the time can be set via the selector switch on the front of the device. The device can be switched on in the buffer mode again after reconnecting the power supply.