



AK4753

2-in, 4-out CODEC with DSP Functions

GENERAL DESCRIPTION

The AK4753 is a two input, four output audio CODEC with integrated digital signal processing. The outputs can be configured either as single-ended or differential. An internal PLL allows the chip to run in master clock free mode. The digital signal processing block includes an ALC/limiter, 5 configurable biquads for EQ, volume control, and 4th-order filters for each output channel to enable a variety of configurations. Wide dynamic range is achieved with 96dB S/N for the ADC, and 103dB S/N for the DAC's. A two-input 8-bit SAR ADC is integrated for processing of external potentiometers, supporting volume and bass control functions. A small external EEP-ROM is used to store the coefficient values for the DSP blocks. The AK4753 is controlled by an I²C control interface.

FEATURES

- Digital audio input interface
 - Data format: MSB-first, two's complement
 - 16, 20, or 24-bits, I2S, MSB justified, LSB justified, or DSP mode
 - Audio sampling rates: 8kHz to 48kHz
- Analog audio input
 - Single-ended input stereo 24-bit audio ADC
 - S/N: 96dB S/(N+D): 85dB
 - Digital high-pass filter for DC-offset correction
- Analog audio output
 - Four-channel 24-bit audio DAC
 - Single-ended or differential output
 - S/N: 103dB S/(N+D): 88dB
- 8-bit SAR ADC with two input selector
- Digital mixer for balancing inputs
- Digital signal processing block: DSP1, DSP2 independently
 - Configurable ALC / limiter function
 - Volume control: 0dB to -127dB, 0.5dB steps, mute
 - Pre-gain setting: 0dB, +6dB, +12dB, +18dB
 - Post-gain setting: 0dB, +3.5dB, +6dB, +8dB
 - Five programmable biquads for EQ
 - 4th-order high-pass filter or low-pass filter
- Integrated PLL for master clock-free operation
- PLL
 - Input frequency: 24.576MHz, 24MHz, 22.5792MHz, 12.288MHz, 12MHz, and 11.2896MHz (XTI/MCKI pin)
1fs (LRCK pin), 32fs or 64fs (BICK pin)
 - Input level: CMOS or AC-coupled (XTI/MCKI pin)
- Master clock input: 256fs, 512fs, 1024fs
- μ P I/F: I²C bus-slave (400kHz Fast-mode)
- EEP-ROM control I/F: I²C bus-master (400kHz Fast-mode)
- Ta = -30 ~ +85°C
- Power supply:
 - Analog (AVDD): 3.0 ~ 3.6V (typ 3.3V)
 - Digital (DVDD): 3.0 ~ 3.6V (typ 3.3V)
- Package: 32 pin QFN (4 x 4 mm, 0.4mm pitch)

■ Block Diagram

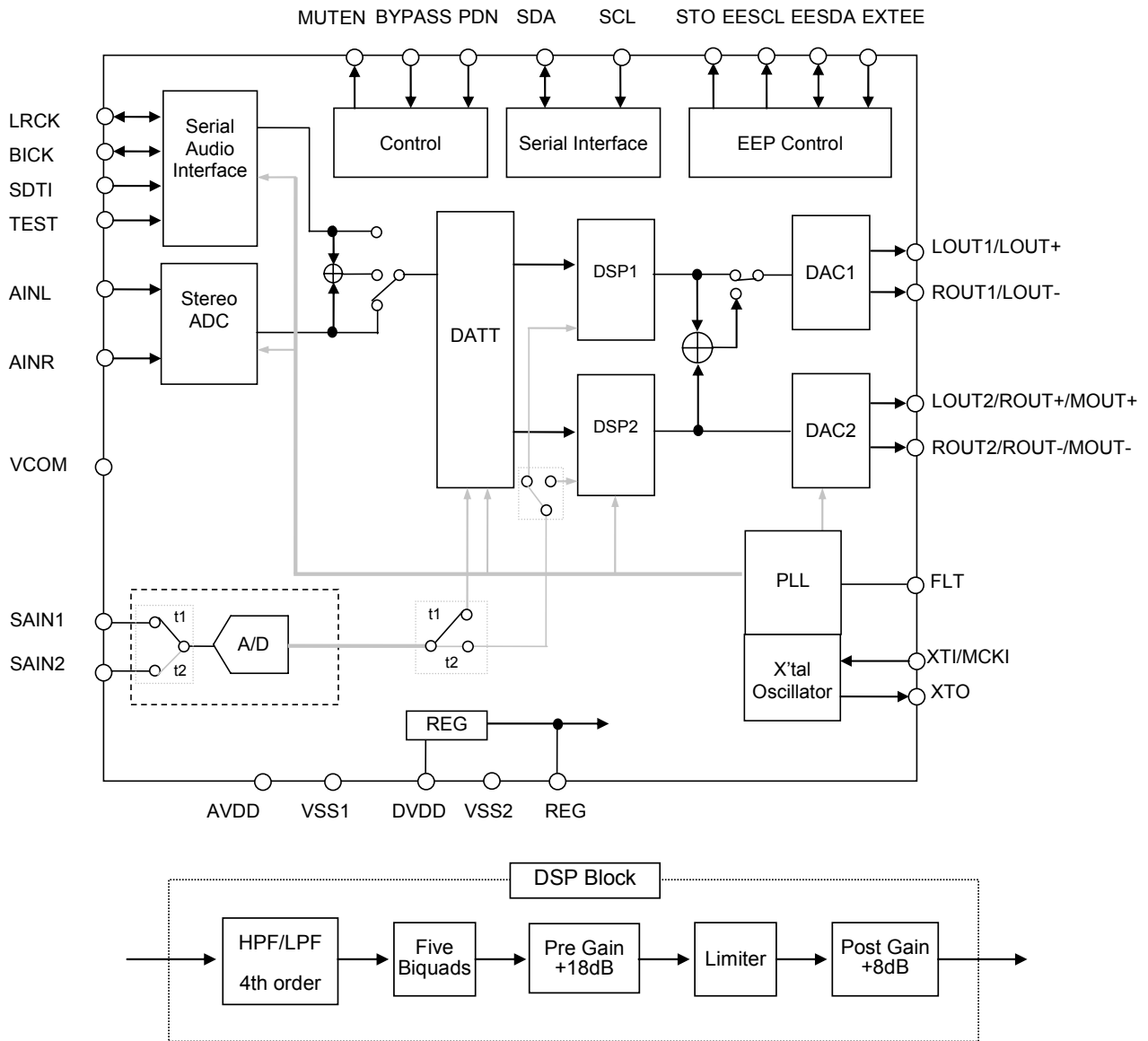
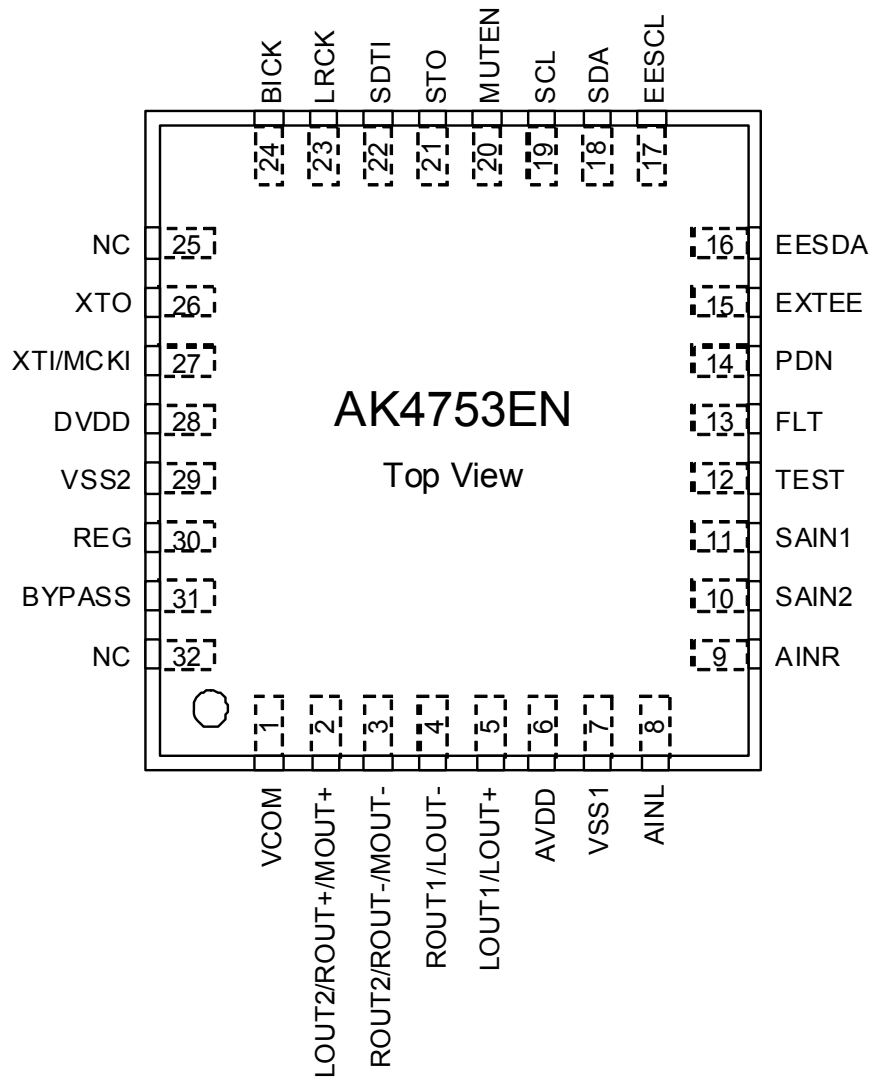

Figure 1. Block Diagram

■ Ordering Guide

AK4753EN -30 ~ +85°C 32 pin QFN (4 x 4 mm, 0.4mm pitch)
 AKD4753 Evaluation Board for AK4753

■ Pin Layout



PIN/FUNCTION			
No.	Pin Name	I/O	Function
1	VCOM	O	Common voltage output pin This pin must be connected to VSS1 with the capacitors of 2.2 μ F capacitor in series.
2	LOUT2	O	Lch Line-Amp Output 2 Pin Single-ended mode (SPC1-0 bits = "11")
	ROUT+	O	Rch Line-Amp Positive Output Pin Differential mode (SPC1-0 bits = "00", "01")
	MOUT+	O	Mono Line-Amp Positive Output Pin Differential mode (SPC1-0 bits = "10")
3	ROUT2	O	Rch Line-Amp Output 2 Pin Single-ended mode (SPC1-0 bits = "11")
	ROUT-	O	Rch Line-Amp Negative Output Pin Differential mode (SPC1-0 bits = "00", "01")
	MOUT-	O	Mono Line-Amp Negative Output Pin Differential mode (SPC1-0 bits = "10")
4	ROUT1	O	Rch Line-Amp Output 1 Pin Single-ended mode (SPC1-0 bits = "10", "11")
	LOUT-	O	Lch Line-Amp Negative Output Pin Differential mode (SPC1-0 bits = "00", "01")
5	LOUT1	O	Lch Line-Amp Output 1 Pin Single-ended mode (SPC1-0 bits = "10", "11")
	LOUT+	O	Lch Line-Amp Positive Output Pin Differential mode (SPC1-0 bits = "00", "01")
6	AVDD	-	Analog Power Supply Pin, 3.0V ~ 3.6V
7	VSS1	-	Ground 1 Pin
8	AINL	I	L channel Analog Input Pin
9	AINR	I	R channel Analog Input Pin
10	SAIN2	I	8-bit SAR ADC Analog Input 2 Pin
11	SAIN1	I	8-bit SAR ADC Analog Input 1 Pin
12	TEST	I	TEST Input pin This pin must be connected to VSS2.
13	FLT	O	PLL Loop Filter Pin This pin must be connected to VSS1 with one resistor and one capacitor in series.
14	PDN	I	Power Down Pin When "L", the AK4753 is in power-down mode and is held in reset. The AK4753 must be always reset upon power-up.
15	EXTEE	I	EEP-ROM Enable Pin "H": EEP-ROM download mode "L": Serial control mode
16	EESDA	I/O	EEP-ROM Control Data Input/Output Pin
17	EESCL	O	EEP-ROM Control Data Clock Output Pin
18	SDA	I/O	Control Data Input/Output Pin
19	SCL	I	Control Data Clock Input Pin
20	MUTEN	O	Mute Control Output Pin. "H": Normal Operation "L": Mute
21	STO	O	EEP-ROM Status Output Pin "H": Read error "L": No error
22	SDTI	I	Audio Serial Data Input Pin
23	LRCK	I/O	Input/Output Channel Clock Pin
24	BICK	I/O	Audio Serial Data Clock Pin
25	NC	-	No Connect Pin No internal bonding. This pin must be connected to VSS2.

No.	Pin Name	I/O	Function
26	XTO	O	X'tal Clock Output Pin
27	XTI	I	X'tal / External Clock Input Pin
	MCKI	I	External Master Clock Input Pin
28	DVDD	-	Digital Power Supply Pin, 3.0V ~ 3.6V
29	VSS2	-	Ground 2 Pin
30	REG	O	Regulator Ripple Filter Pin This pin must be connected to VSS2 with 2.2 μ F capacitor in series.
31	BYPASS	I	Bypass Control Input Pin "H": DSP Bypass mode "L": Normal Operation
32	NC	-	No Connect Pin No internal bonding. This pin must be connected to VSS2.

Note 1. All input pins except analog input pins (AINL, AINR, SAIN1, SAIN2) must not be left floating.

■ Handling of Unused Pin

The unused I/O pins must be processed appropriately as below.

Classification	Pin Name	Setting
Analog	AINL, AINR, SAIN1, SAIN2, FLT, LOUT1/LOUT+, ROUT1/LOUT-, LOUT2/ROUT+/MOUT+, ROUT2/ROUT-/MOUT-	Open
Digital	XTO, SDA, EESDA, EESCL, MUTEN, STO	Open
	LRCK, BICK, SDTI, XTI/MCKI, EXTEE, TEST, SCL	These pins must be connected to VSS2.

ABSOLUTE MAXIMUM RATINGS

(All VSS pins =0V; [Note 2](#))

Parameter		Symbol	min	max	Unit
Power Supplies:	Analog	AVDD	-0.3	4.2	V
	Digital	DVDD	-0.3	4.2	V
Analog Input Voltage (Note 3)		VINA1	-0.3	AVDD+0.3	V
Digital Input Voltage (Note 4)		VIND	-0.3	DVDD+0.3	V
Input Current, Any Pin Except Supplies		IIN	-10	+10	mA
Ambient Operating Temperature		Ta	-30	85	°C
Storage Temperature		Tstg	-65	150	°C

Note 2. All voltage with respect to ground. All VSS pins must be connected to the common analog ground.

Note 3. AINL pin, AINR pin, SAIN1 pin, SAIN2 pin.

Note 4. BYPASS, PDN, EESDA, XTI/MCKI, BICK, LRCK, SDTI, SCL, SDA, TEST pins

WARNING: Operation at or beyond these limits may result in permanent damage to the device. Normal operation is not guaranteed at these extremes.

RECOMMENDED OPERATING CONDITIONS

(All VSS pins =0V; [Note 2](#))

Parameter		Symbol	min	typ	max	Unit
Power Supplies (Note 5)	Analog	AVDD	3.0	3.3	3.6	V
	Digital	DVDD	3.0	3.3	3.6	V
	Difference	DVDD-AVDD	-	0	0.3	V

Note 5. The power up sequence between AVDD and DVDD is not critical. Each power supplies should be powered up during the PDN pin = "L". AVDD and DVDD must be the same voltage at the PDN pin = "H". The PDN pin should be "H" after all power supplies are powered up. All power supplies should be powered on, only a part of these power supplies cannot be powered off. (Power off means power supplies equal to ground or power supplies are floating.) Do not turn off only the AK4753 under the condition that a surrounding device is powered on and the I2C bus is in use.

WARNING: AKM assumes no responsibility for the usage beyond the conditions in this datasheet.

ANALOG CHARACTERISTICS (CODEC)

(Ta=25°C; AVDD=DVDD=3.3V; VSS1=VSS2=0V; fs=44.1kHz; BICK=64fs; Signal Frequency=1kHz; 24-bit Data; Measurement Band Width =20Hz~20kHz; unless otherwise specified)

Parameter		min	typ	max	Unit
DAC Analog Output Characteristics: DAC → LOUT1/ROUT1, LOUT2/ROUT2 pins, Single-ended mode (SPC1-0 bits = “11”), HPF=LPF=EQ(5-BiQuads)=Limiter=OFF, DATT= 0dB, RL=5kΩ					
Resolution		-	-	24	Bits
S/(N+D)	(0dBFS)	75	85	-	dB
DR	(-60dBFS with A-weighted)	87	97	-	dB
S/N	(A-weighted)	87	97	-	dB
Interchannel Isolation		80	95	-	dB
Interchannel Gain Mismatch		-	0	0.5	dB
Output Voltage	AOUT=0.68 x AVDD	1.98	2.24	2.51	Vpp
Load Resistance	(AC load)	5	-	-	kΩ
Load Capacitance		-	-	150	pF
Power Supply Rejection Ratio	(Note 6)	-	50	-	dB
DAC Analog Output Characteristics: DAC → LOUT+/-, ROUT+/- pins, Differential mode (SPC1-0 bits = “00”), HPF=LPF=EQ(5-BiQuads)=Limiter=OFF, DATT= 0dB, RL=5kΩ					
S/(N+D)	(0dBFS)	78	88	-	dB
DR	(-60dBFS with A-weighted)	93	103	-	dB
S/N	(A-weighted)	93	103	-	dB
Interchannel Isolation		95	110	-	dB
Interchannel Gain Mismatch		-	0	0.5	dB
Output Voltage	AOUT=0.70 x AVDD	±2.08	±2.31	±2.54	Vpp
Load Resistance	(AC load)	5	-	-	kΩ
Load Capacitance		-	-	150	pF
Power Supply Rejection	(Note 6)	-	50	-	dB
ADC to DAC Characteristics: AINL/AINR pins → DAC → LOUT1/ROUT1, LOUT2/ROUT2 pins, Single-ended mode (SPC1-0 bits = “11”), HPF=LPF=EQ(5-BiQuads)=Limiter=OFF, DATT= 0dB, RL=5kΩ					
Input Voltage	AIN=0.8xAVDD	2.38	2.64	2.90	Vpp
Input Resistance		24	35	-	kΩ
S/(N+D)	(-1dBFS)	73	84	-	dB
DR	(-60dBFS with A-weighted)	83	94	-	dB
S/N	(A-weighted)	83	94	-	dB
ADC to DAC Characteristics: AINL/AINR pins → DAC → LOUT+/-, ROUT+/- pins, Differential mode (SPC1-0 bits = “00”, “01”), HPF=LPF=EQ(5-BiQuads)=Limiter=OFF, DATT= 0dB, RL=5kΩ					
Input Voltage	AIN=0.8xAVDD	2.38	2.64	2.90	Vpp
Input Resistance		24	35	-	kΩ
S/(N+D)	(-1dBFS)	74	85	-	dB
DR	(-60dBFS with A-weighted)	85	96	-	dB
S/N	(A-weighted)	85	96	-	dB

Note 6. PSRR is applied to AVDD and DVDD with 1kHz, 50mVpp.

Parameter	min	typ	max	Unit
Power Supplies				
All Circuit Power-up (PDN pin = "H") (Note 7)				
Differential Mode (SPC1-0 bits = "00")				
AVDD	-	5.8	8.7	mA
DVDD	-	4.2	6.3	mA
Single-ended Mode (SPC1-0 bits = "11")				
AVDD	-	9.0	13.5	mA
DVDD	-	4.6	6.9	mA
Power-down (PDN pin = "L") (Note 7)				
AVDD + DVDD	-	1	10	μA

Note 7. PLL Master Mode (MCKI=12MHz), PMAD=PMDIG=PMLO1=PMLO2=PMSAR=PMPLL bits = "1".

Note 8. All digital input pins are fixed to DVDD or VSS2.

ANALOG CHARACTERISTICS (8-bit SAR ADC)

(Ta=25°C; AVDD=DVDD =3.3V; VSS1=VSS2=0V; unless otherwise specified)

Parameter	min	typ	max	Units
8-bit SAR ADC Characteristics				
Resolution	-	8	-	Bits
No Missing Codes	7	8	-	Bits
Integral Nonlinearity Error	-	-	±1	LSB
Differential Nonlinearity Error	-	-	±1	LSB
Analog Input Voltage Range	0	-	AVDD	V
Offset Error	-	-	±1	LSB
Gain Error	-	-	±1	LSB
Accuracy (Note 9)	-	-	±1.2	%
Potentiometer Resistance (Figure 2)	VR	-	100	kΩ

Note 9. Accuracy is the difference between the output code when 1.1V is input to SAIN1 or SAIN2 pin and the "ideal" code at 1.1V.

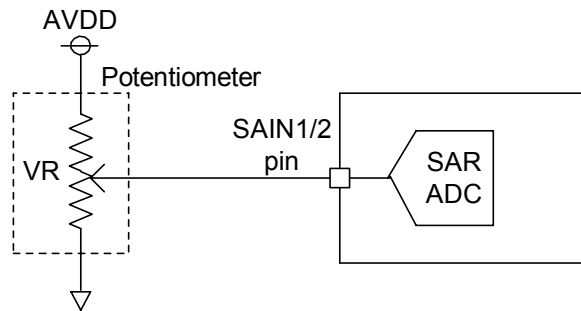

Figure 2. Potentiometer Resistance

FILTER CHARACTERISTICS

(Ta = -30 ~ 85°C; AVDD=DVDD=3.0V ~ 3.6V; fs=44.1kHz; HPF=LPF=EQ(5-BiQuads)=Limiter=OFF)

Parameter		Symbol	min	typ	max	Unit
ADC Digital Filter (Decimation LPF):						
Passband (Note 10)	±0.16dB	PB	0	-	17.3	kHz
	-0.66dB		-	19.4	-	kHz
	-1.1dB		-	19.9	-	kHz
	-6.9dB		-	22.1	-	kHz
Stopband		SB	26.1	-	-	kHz
Passband Ripple		PR	-	-	±0.16	dB
Stopband Attenuation		SA	73	-	-	dB
Group Delay (Note 11)		GD	-	15	-	1/fs
Group Delay Distortion		ΔGD	-	0	-	μs
ADC Digital Filter (HPF):						
Frequency Response	-3.0dB	FR	-	0.9	-	Hz
	-0.1dB		-	6.0	-	Hz
DAC Digital Filter:						
Passband (Note 12)	±0.05dB	PB	0	-	20.0	kHz
	-6.0dB		-	22.05	-	kHz
Stopband		SB	24.1	-	-	kHz
Passband Ripple		PR	-	-	±0.05	dB
Stopband Attenuation		SA	53	-	-	dB
Group Delay (Note 13)		GD	-	25	-	1/fs
DAC Digital Filter (LPF) + SCF:						
Frequency Response: 0 ~ 20.0kHz		FR	-	±0.4	-	dB

Note 10. The passband and stopband frequencies scale with fs (system sampling rate). Each response refers to that of 1kHz.

Note 11. A calculating delay time which induced by digital filtering. This time is from the input of an analog signal to the setting of 24-bit data of both channels to the ADC output register.

Note 12. The passband and stopband frequencies scale with fs (system sampling rate). Each response refers to that of 1kHz.

Note 13. A calculating delay time which induced by digital filtering. This time is from setting the 24-bit data of both channels to input register to the output of analog signal.

DC CHARACTERISTICS

(Ta = -30 ~ 85°C; AVDD=DVDD= 3.0V ~ 3.6V)

Parameter	Symbol	min	typ	max	Unit
High-Level Input Voltage	VIH	70%DVDD	-	-	V
Low-Level Input Voltage	VIL	-	-	30%DVDD	V
Input Voltage at AC Coupling (XTI/MCKI pin) (Note 14)	VAC	40%DVDD	-	-	Vpp
High-Level Output Voltage (Iout = -100μA) (Note 15)	VOH	DVDD-0.4	-	-	V
Low-Level Output Voltage (Except SDA, EESDA, EESCL pins: Iout = 100μA) (SDA, EESDA, EESCL pins: Iout = 3mA) (Note 15)	VOL	-	-	0.4	V
	VOL	-	-	0.4	V
Input Leakage Current	Iin	-	-	±10	μA

Note 14. It is a case when AC coupling capacitor is connected to the XTI/MCKI pin.

Note 15. Except XTO pin.

SWITCHING CHARACTERISTICS

(Ta=-30 ~ 85°C, AVDD= DVDD= 3.0V ~ 3.6V, C₁=20pF; unless otherwise specified)

Parameter	Symbol	min	typ	max	Unit
Crystal Resonator					
Frequency	fXTAL	11.2896	-	12.288	MHz
PLL Master Mode (PLL Reference Clock = XTI/MCKI pin)					
MCKI Input Timing					
Frequency	fCLK	11.2896	-	24.576	MHz
Pulse Width Low	tCLKL	0.4/fCLK	-	-	ns
Pulse Width High	tCLKH	0.4/fCLK	-	-	ns
AC Pulse Width	tACW	18.5	-	-	ns
LRCK Output Timing					
Frequency	fs	-	Table 6	-	kHz
DSP Mode: Pulse Width High	tLRCKH	-	tBCK	-	ns
Except DSP Mode: Duty Cycle	Duty	-	50	-	%
BICK Output Timing					
Period	BCKO bit = "0"	tBCK	-	1/(32fs)	ns
	BCKO bit = "1"	tBCK	-	1/(64fs)	ns
Duty Cycle	dBCK	-	50	-	%
PLL Slave Mode (PLL Reference Clock = LRCK pin)					
LRCK Input Timing					
Frequency	fs	7.35	-	48	kHz
DSP Mode: Pulse Width High	tLRCKH	tBCK-60	-	1/fs - tBCK	ns
Except DSP Mode: Duty Cycle	Duty	45	-	55	%
BICK Input Timing					
Period	tBCK	1/(64fs)	-	1/(32fs)	ns
Pulse Width Low	tBCKL	130	-	-	ns
Pulse Width High	tBCKH	130	-	-	ns
PLL Slave Mode (PLL Reference Clock = BICK pin)					
LRCK Input Timing					
Frequency	fs	7.35	-	48	kHz
DSP Mode: Pulse Width High	tLRCKH	tBCK-60	-	1/fs - tBCK	ns
Except DSP Mode: Duty Cycle	Duty	45	-	55	%
BICK Input Timing					
Period	PLL3-0 bits = "0010"	tBCK	-	1/(32fs)	ns
	PLL3-0 bits = "0011"	tBCK	-	1/(64fs)	ns
Pulse Width Low	tBCKL	0.4 x tBCK	-	-	ns
Pulse Width High	tBCKH	0.4 x tBCK	-	-	ns

Parameter	Symbol	min	typ	max	Unit	
External Slave Mode						
MCKI Input Timing						
Frequency	256fs	fCLK	1.8816	-	12.288	MHz
	512fs	fCLK	3.7632	-	13.312	MHz
	1024fs	fCLK	7.5264	-	13.312	MHz
Pulse Width Low	tCLKL	0.4/fCLK	-	-	ns	
Pulse Width High	tCLKH	0.4/fCLK	-	-	ns	
LRCK Input Timing						
Frequency	256fs	fs	7.35	-	48	kHz
	512fs	fs	7.35	-	26	kHz
	1024fs	fs	7.35	-	13	kHz
DSP Mode: Pulse Width High	tLRCKH	tBCK-60	-	1/fs - tBCK	ns	
Except DSP Mode: Duty Cycle	Duty	45	-	55	%	
BICK Input Timing						
Period (Note 16)	tBCK	312.5 or 1/(126fs)	-	-	ns s	
Pulse Width Low	tBCKL	130	-	-	ns	
Pulse Width High	tBCKH	130	-	-	ns	
External Master Mode						
MCKI Input Timing						
Frequency	256fs	fCLK	1.8816	-	12.288	MHz
	512fs	fCLK	3.7632	-	13.312	MHz
	1024fs	fCLK	7.5264	-	13.312	MHz
Pulse Width Low	tCLKL	0.4/fCLK	-	-	ns	
Pulse Width High	tCLKH	0.4/fCLK	-	-	ns	
LRCK Output Timing						
Frequency	fs	7.35	-	48	kHz	
DSP Mode: Pulse Width High	tLRCKH	-	tBCK	-	ns	
Except DSP Mode: Duty Cycle	Duty	-	50	-	%	
BICK Output Timing						
Period	BCKO bit = "0"	tBCK	-	1/(32fs)	-	ns
	BCKO bit = "1"	tBCK	-	1/(64fs)	-	ns
Duty Cycle	dBCK	-	50	-	%	

Note 16. The minimum value is longer time between 312.5ns and 1/(126fs).

Parameter	Symbol	min	typ	max	Unit
Audio Interface Timing (DSP Mode)					
Master Mode					
LRCK “↑” to BICK “↑” (Note 17)	tDBF	0.5 x tBCK -40	0.5 x tBCK	0.5 x tBCK +40	ns
LRCK “↑” to BICK “↓” (Note 18)	tDBF	0.5 x tBCK -40	0.5 x tBCK	0.5 x tBCK +40	ns
SDTI Hold Time	tSDH	50	-	-	ns
SDTI Setup Time	tSDS	50	-	-	ns
Slave Mode					
LRCK “↑” to BICK “↑” (Note 17)	tLRB	0.4 x tBCK	-	-	ns
LRCK “↑” to BICK “↓” (Note 18)	tLRB	0.4 x tBCK	-	-	ns
BICK “↑” to LRCK “↑” (Note 17)	tBLR	0.4 x tBCK	-	-	ns
BICK “↓” to LRCK “↑” (Note 18)	tBLR	0.4 x tBCK	-	-	ns
SDTI Hold Time	tSDH	50	-	-	ns
SDTI Setup Time	tSDS	50	-	-	ns
Audio Interface Timing (Right/Left justified & I²S)					
Master Mode					
BICK “↓” to LRCK Edge (Note 19)	tMBLR	-40	-	40	ns
SDTI Hold Time	tSDH	50	-	-	ns
SDTI Setup Time	tSDS	50	-	-	ns
Slave Mode					
LRCK Edge to BICK “↑” (Note 19)	tLRB	50	-	-	ns
BICK “↑” to LRCK Edge (Note 19)	tBLR	50	-	-	ns
SDTI Hold Time	tSDH	50	-	-	ns
SDTI Setup Time	tSDS	50	-	-	ns

Note 17. MSBS, BCKP bits = “00” or “11”.

Note 18. MSBS, BCKP bits = “01” or “10”.

Note 19. BICK rising edge must not occur at the same time as LRCK edge.

Parameter	Symbol	min	typ	max	Unit
Control Interface Timing (I²C bus-slave): SCL, SDA pins (Note 20)					
SCL Clock Frequency	fSCL1	-	-	400	kHz
Bus Free Time Between Transmissions	tBUF1	1.3	-	-	μs
Start Condition Hold Time (prior to first clock pulse)	tHD1:STA	0.6	-	-	μs
Clock Low Time	tLOW1	1.3	-	-	μs
Clock High Time	tHIGH1	0.6	-	-	μs
Setup Time for Repeated Start Condition	tSU1:STA	0.6	-	-	μs
SDA Hold Time from SCL Falling (Note 21)	tHD1:DAT	0	-	-	μs
SDA Setup Time from SCL Rising	tSU1:DAT	0.1	-	-	μs
Rise Time of Both SDA and SCL Lines	tR1	-	-	0.3	μs
Fall Time of Both SDA and SCL Lines	tF1	-	-	0.3	μs
Capacitive Load on Bus	Cb1	-	-	400	pF
Setup Time for Stop Condition	tSU1:STO	0.6	-	-	μs
Pulse Width of Spike Noise Suppressed by Input Filter	tSP1	0	-	50	ns
EEP-ROM Control Interface Timing (I²C bus-master): EESCL, EESDA pins (Note 20)					
EESCL Clock Frequency	fSCL2	200	280	400	kHz
Bus Free Time Between Transmissions	tBUF2	1.3	-	-	μs
Start Condition Hold Time (prior to first clock pulse)	tHD:STA2	0.6	-	-	μs
Clock Low Time	tLOW2	1.3	-	-	μs
Clock High Time	tHIGH2	0.6	-	-	μs
Setup Time for Repeated Start Condition	tSU2:STA	0.6	-	-	μs
EESDA Hold Time from EESCL Falling (Note 21)	tHD2:DAT	0	-	0.9	μs
EESDA Setup Time from EESCL Rising	tSU2:DAT	0.1	-	-	μs
Rise Time of Both EESDA and EESCL Lines	tR2	-	-	0.3	μs
Fall Time of Both EESDA and EESCL Lines	tF2	-	-	0.3	μs
Capacitive Load on Bus	Cb2	-	-	400	pF
Setup Time for Stop Condition	tSU2:STO	0.6	-	-	μs
Pulse Width of Spike Noise Suppressed by Input Filter	tSP2	0	-	50	ns
Power-down & Reset Timing					
PDN Pulse Width (Note 22)	tPD	10	-	-	ms

Note 20. I²C-bus is a trademark of NXP B.V.

Note 21. Data must be held long enough to bridge the 300ns-transition time of SCL and EESCL.

Note 22. The AK4753 can be reset by the PDN pin = "L".

■ Timing Diagram

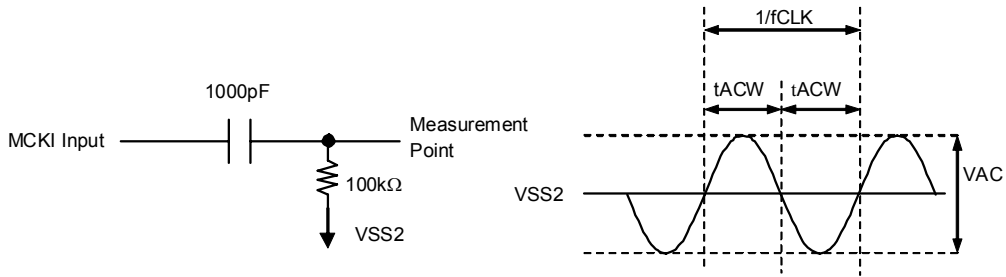

Figure 3. MCKI AC Coupling Timing

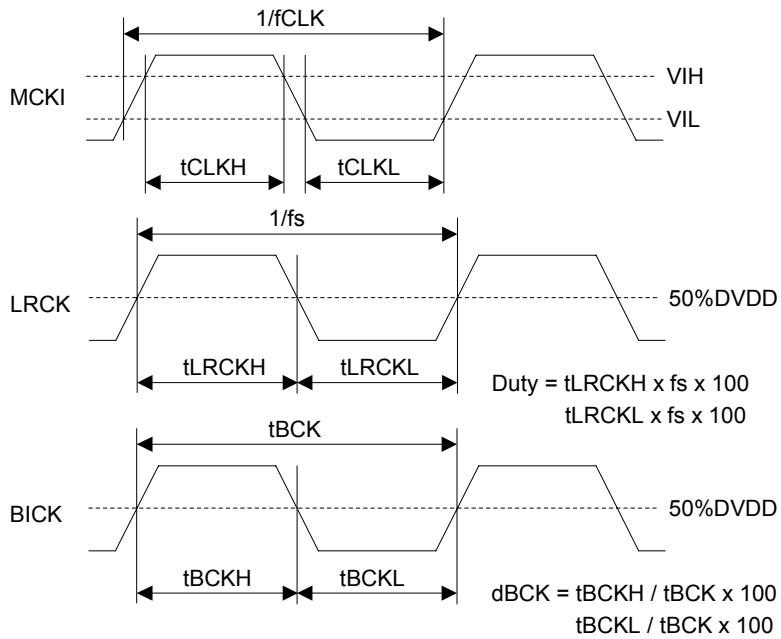

Figure 4. Clock Timing (PLL/EXT Master mode)

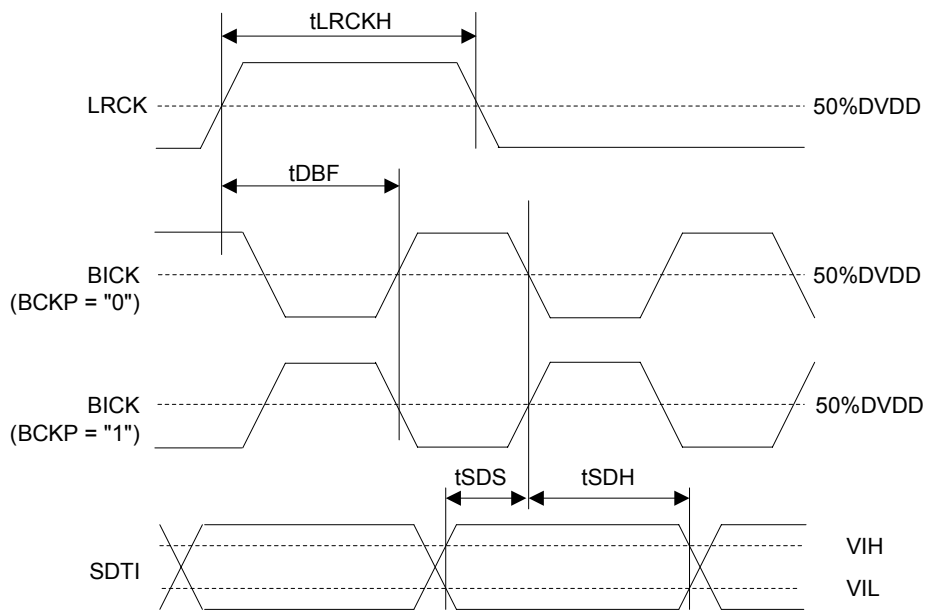

Figure 5. Audio Interface Timing (PLL/EXT Master mode, DSP mode, MSBS = "0")

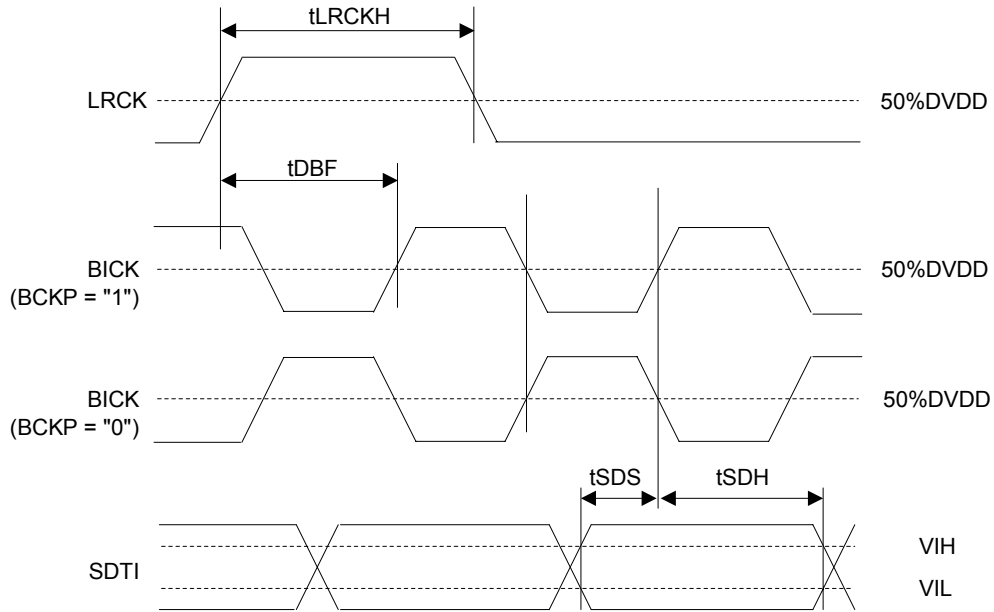

Figure 6. Audio Interface Timing (PLL/EXT Master mode, DSP mode, MSBS = "1")

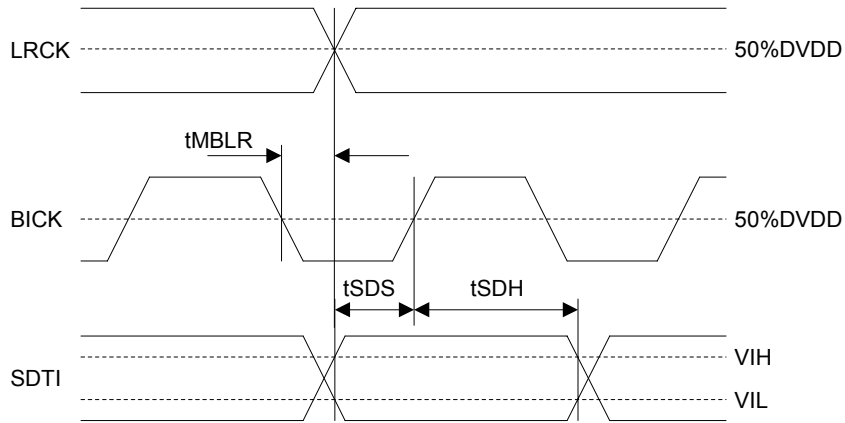

Figure 7. Audio Interface Timing (PLL/EXT Master mode, Except DSP mode)

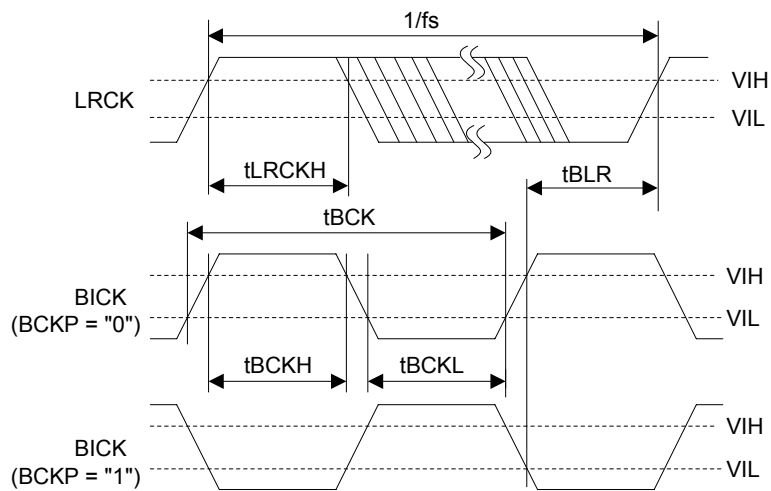

Figure 8. Clock Timing (PLL Slave mode; PLL Reference Clock = LRCK or BICK pin, DSP mode, MSBS = "0")

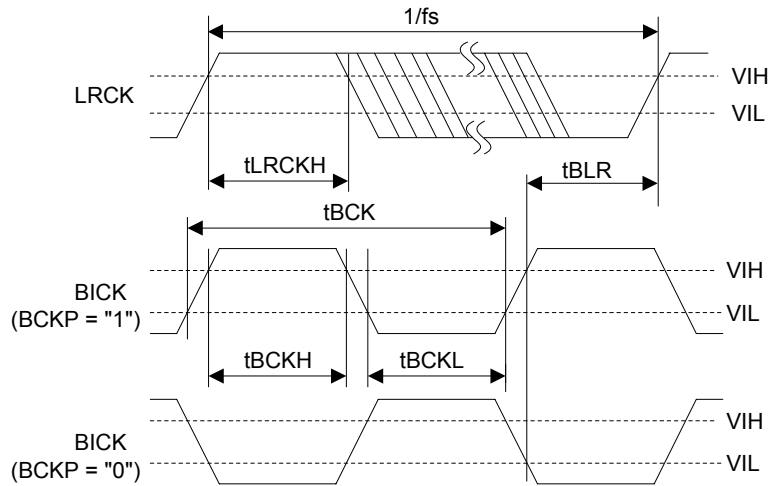

Figure 9. Clock Timing (PLL Slave mode; PLL Reference Clock = LRCK or BICK pin, DSP mode, MSBS = "1")

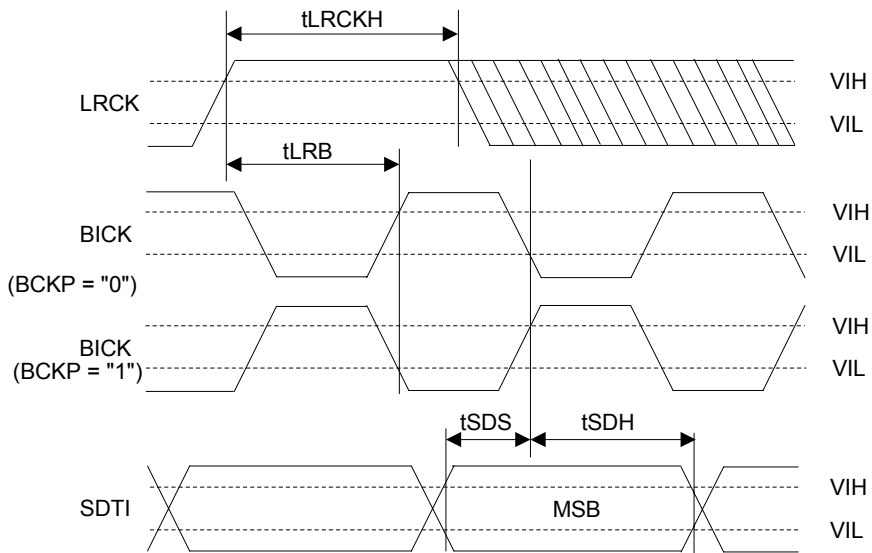

Figure 10. Audio Interface Timing (PLL Slave mode, DSP mode; MSBS = "0")

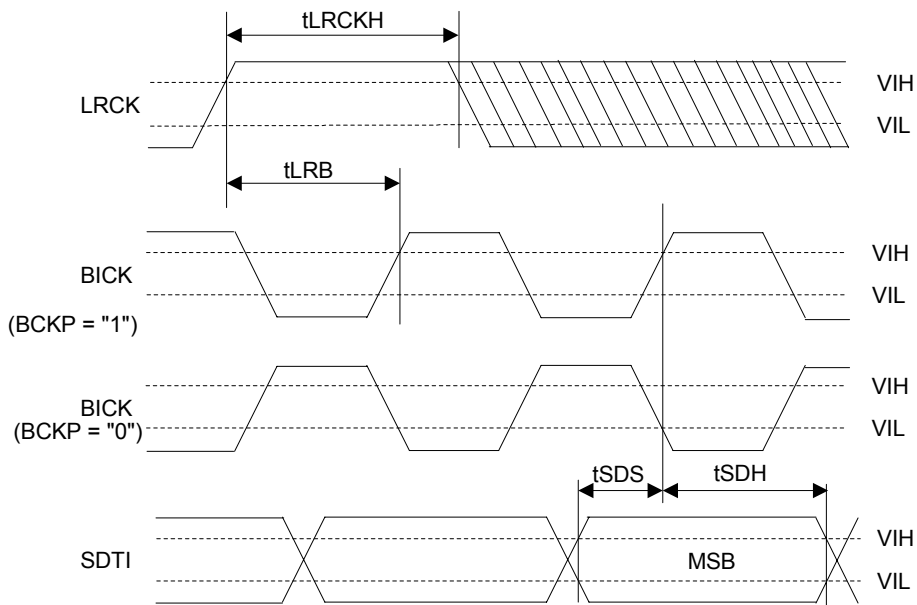

Figure 11. Audio Interface Timing (PLL Slave mode, DSP mode, MSBS = "1")

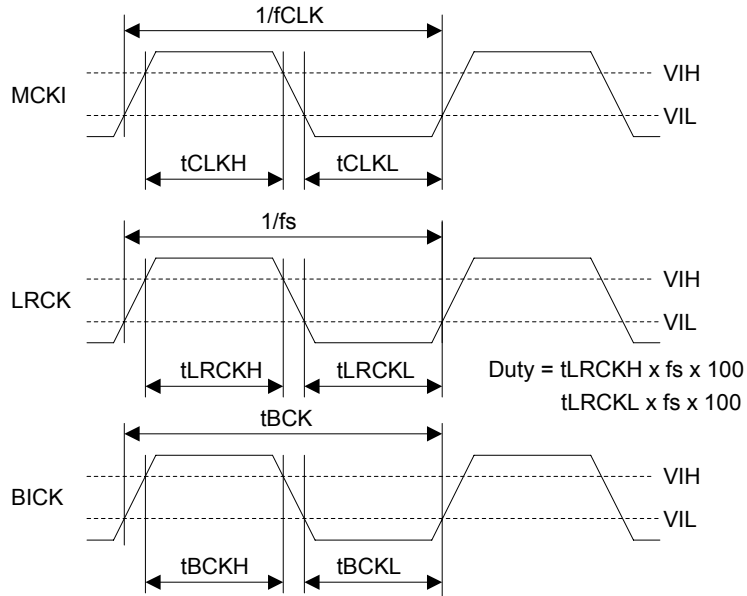

Figure 12. Clock Timing (EXT Slave mode)

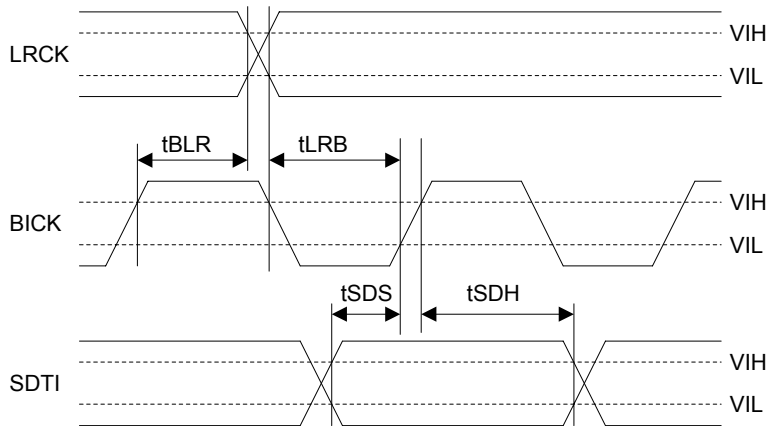

Figure 13. Audio Interface Timing (PLL/EXT Slave mode, Except DSP mode)

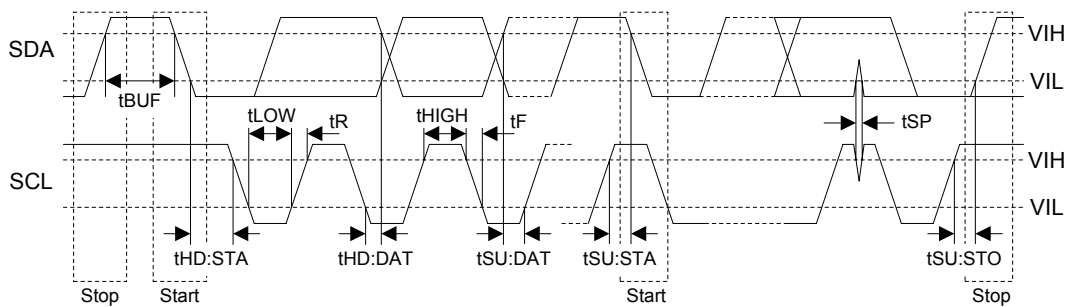

Figure 14. I²C Bus Mode Timing

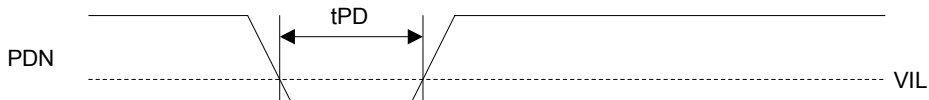

Figure 15. Power Down & Reset Timing

OPERATION OVERVIEW**■ Overview of AK4753**

The AK4753 is an audio CODEC with integrated digital signal processors.

It is easy to use since the two inputs 8-bit SAR ADC and EEPROM I/F are integrated.

The SAR ADC has 2-channel input selector and the AD conversion is executed sequentially.

The SAIN1 value is used to control the internal DATT. The SAIN2 value is used to control the gain of the EQ. When the analog input of the SAIN1/2 changes, the register value of the DATT/EQ is changed automatically.

This external EEPROM is used to store the coefficient values for the DSP blocks, and the setting data. When the AK4753 is powered up, it reads the data in EEPROM at first, and maps these values into the internal registers.

The following contents are stored in EEPROM.

a. Fundamental function

- Output Configuration Setting (Stereo mode, 2.1-channel mode or 4-channel mode)
- PLL mode setting: master or slave, PLL Reference Clock, Sampling Frequency
- Audio Interface Format
- DATT
- Post-Gain and Pre-Gain setting for DSP1/2
- Limiter setting for DSP1/2

b. Coefficient data for DSP1/2

- Coefficient data of LPF/HPF
- Coefficient data of Five Biquads

■ System Clock

There are the following four methods to interface with external devices. (Table 1, Table 2)

Mode	PMPLL bit	M/S bit	PLL3-0 bits	Figure
PLL Master Mode	1	1	Table 4	Figure 20 Figure 21
PLL Slave Mode (PLL Reference Clock: LRCK or BICK pin)	1	0	Table 4	Figure 22 Figure 23
EXT Slave Mode	0	0	x	Figure 24
EXT Master Mode	0	1	x	Figure 25 Figure 26

Table 1. Clock Mode Setting (x: Don't care)

Mode	XTI/MCKI pin	BICK pin	LRCK pin
PLL Master Mode	Selected by PLL3-0 bits	Output (Selected by BCKO bit)	Output (1fs)
PLL Slave Mode (PLL Reference Clock: LRCK or BICK pin)	GND	Input (Selected by PLL3-0 bits)	Input (1fs)
EXT Slave Mode	Selected by FS1-0 bits	Input (≥ 32fs)	Input (1fs)
EXT Master Mode	Selected by FS1-0 bits	Output (Selected by BCKO bit)	Output (1fs)

Table 2. Clock pins state in Clock Mode

■ Master Mode/Slave Mode

The M/S bit selects either master or slave mode. M/S bit = "1" selects master mode and "0" selects slave mode. When the AK4753 is in power-down mode (PDN pin = "L") and when exits reset state, the AK4753 is in slave mode. After exiting reset state, the AK4753 goes to master mode by changing M/S bit = "1".

When the AK4753 is in master mode, the LRCK and BICK pins are a floating state until M/S bit becomes "1". The LRCK and BICK pins of the AK4753 must be pulled-down or pulled-up by the resistor (about 100kΩ) externally to avoid the floating state.

M/S bit	Mode
0	Slave Mode
1	Master Mode

(default)

Table 3. Select Master/Slave Mode

■ Crystal Oscillator Circuit

A clock for the XTI/MCKI pin can be generated by the following three methods.

1. X'tal Mode (PWXTAL bit= "1")

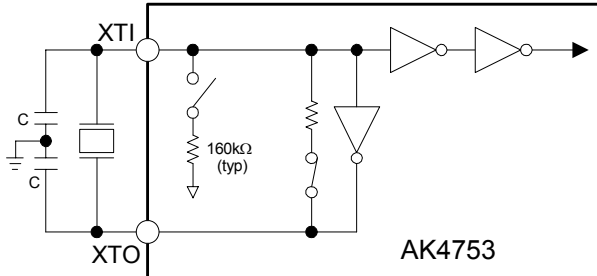

Figure 16. X'tal Mode

Note: The value of the capacitor depends on a crystal (Typ.10-40pF).

2. External Clock Mode (PWXTAL bit= "1")

Note: Do not input a clock beyond the voltage of DVDD.

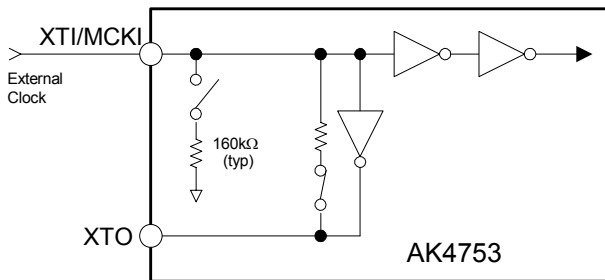

Figure 17. Direct Connection
(Input: CMOS Level)

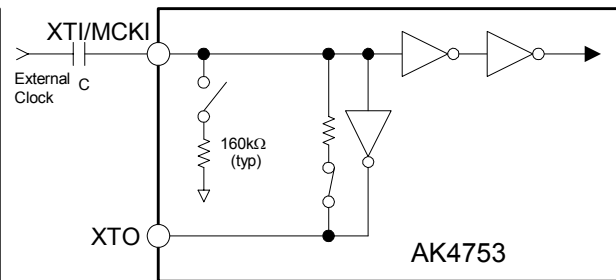

Figure 18. AC Coupling Connection
(Input: $\geq 40\%DVDD$, C=1000pF)

3. OFF Mode of XTI/MCKI, XTO pins (PWXTAL bit= "0")

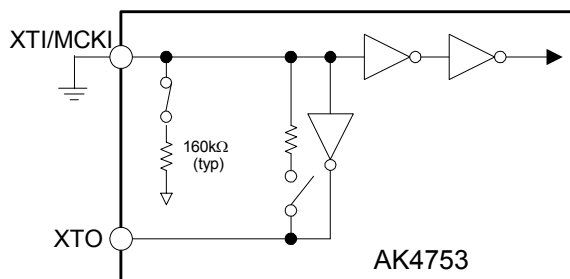

Figure 19. OFF Mode

■ PLL Mode (PMPLL bit = “1”)

When PMPLL bit = “1”, the built-in high precision PLL works according to the clock which is set by FS3-0 bits and PLL3-0 bits. The PLL lock time is shown in Table 4, whenever the AK4753 is supplied to a stable clock after PLL is powered-up (PMPLL bit = “0” → “1”) or sampling frequency changes.

1. PLL Mode setting

Mode	PLL3 bit	PLL2 bit	PLL1 bit	PLL0 bit	PLL Reference Clock Input Pin	Input Frequency	FLT pin Rp, Cp		PLL Lock Time (max)
							Rp[Ω]	Cp[F]	
0	0	0	0	0	LRCK pin	1fs	10k	100n	40 ms
1	0	0	1	0	BICK pin	32fs	10k	4.7n	4 ms
2	0	0	1	1	BICK pin	64fs	10k	4.7n	4 ms
3	0	1	0	0	XTI/MCKI pin	11.2896MHz	10k	4.7n	4 ms
4	0	1	0	1	XTI/MCKI pin	12.288MHz	10k	4.7n	4 ms
5	0	1	1	0	XTI/MCKI pin	12MHz	10k	4.7n	4 ms
6	0	1	1	1	XTI/MCKI pin	24MHz	10k	4.7n	4 ms
7	1	1	0	0	XTI/MCKI pin	22.5792MHz	10k	4.7n	4 ms
8	1	1	0	1	XTI/MCKI pin	24.576MHz	10k	4.7n	4 ms
Others	Others				N/A				

(*fs: Sampling Frequency, N/A: Not Available)

Table 4. PLL Mode Setting

2. Sampling Frequency setting in PLL Mode (PLL reference clock pin: XTI/MCKI pin)

In the case of PLL2 bit = “1”, and the reference clock is input to the XTI/MCKI pin or the crystal oscillator circuit is used, the sampling frequency can be set according to Table 5.

Mode	FS3 bit	FS2 bit	FS1 bit	FS0 bit	Sampling Frequency (Note 23)
0	0	0	0	0	8kHz mode
1	0	0	0	1	12kHz mode
2	0	0	1	0	16kHz mode
3	0	0	1	1	24kHz mode
4	0	1	0	0	7.35kHz mode
5	0	1	0	1	11.025kHz mode
6	0	1	1	0	14.7kHz mode
7	0	1	1	1	22.05kHz mode
10	1	0	1	0	32kHz mode
11	1	0	1	1	48kHz mode
14	1	1	1	0	29.4kHz mode
15	1	1	1	1	44.1kHz mode
Others	Others				N/A

(Reference Clock = XTI/MCKI pin) (N/A: Not Available)

Table 5. Sampling Frequency Setting (PMPLL bit = “1”)

Note 23. When the XTI/MCKI pin is the PLL reference clock input, the sampling frequency generated by PLL differs from the sampling frequency of mode name in some combinations of MCKI frequency(PLL3-0 bits) and sampling frequency (FS3-0 bits). Refer to Table 6 for the details of sampling frequency. In master mode, LRCK and BICK output frequency correspond to sampling frequencies shown in Table 6. When the LRCK or BICK pin is the PLL reference clock input, the sampling frequency generated by PLL is the same sampling frequency of mode name.

Input Frequency MCKI[MHz]	Sampling Frequency Mode	Sampling Frequency generated by PLL [kHz] (Note 24)
11.2896	8kHz mode	8.000000
	12kHz mode	12.000000
	16kHz mode	16.000000
	24kHz mode	24.000000
	32kHz mode	32.000000
	48kHz mode	48.000000
	11.025kHz mode	11.025000
	22.05kHz mode	22.050000
	44.1kHz mode	44.100000
	7.35kHz mode	7.350000
	14.7kHz mode	14.700000
29.4kHz mode	29.400000	
12.288	8kHz mode	8.000000
	12kHz mode	12.000000
	16kHz mode	16.000000
	24kHz mode	24.000000
	32kHz mode	32.000000
	48kHz mode	48.000000
	11.025kHz mode	11.025000
	22.05kHz mode	22.050000
	44.1kHz mode	44.100000
	7.35kHz mode	7.350000
	14.7kHz mode	14.700000
29.4kHz mode	29.400000	
12	8kHz mode	8.000000
	12kHz mode	12.000000
	16kHz mode	16.000000
	24kHz mode	24.000000
	32kHz mode	32.000000
	48kHz mode	48.000000
	11.025kHz mode	11.024877
	22.05kHz mode	22.049753
	44.1kHz mode	44.099507
	7.35kHz mode	7.349918
	14.7kHz mode	14.699836
29.4kHz mode	29.399671	
	Sampling frequency that differs from sampling frequency of mode name	

Note 24. These are rounded off to six decimal places.

Table 6. Sampling Frequency at PLL mode (Reference clock is MCKI)

Input Frequency MCKI [MHz]	Sampling Frequency Mode	Sampling Frequency generated by PLL [kHz] (Note 24)
24	8kHz mode	8.000000
	12kHz mode	12.000000
	16kHz mode	16.000000
	24kHz mode	24.000000
	32kHz mode	32.000000
	48kHz mode	48.000000
	11.025kHz mode	11.024877
	22.05kHz mode	22.049753
	44.1kHz mode	44.099507
	7.35kHz mode	7.349918
	14.7kHz mode	14.699836
29.4kHz mode	29.399671	
22.5792	8kHz mode	8.000000
	12kHz mode	12.000000
	16kHz mode	16.000000
	24kHz mode	24.000000
	32kHz mode	32.000000
	48kHz mode	48.000000
	11.025kHz mode	11.025000
	22.05kHz mode	22.050000
	44.1kHz mode	44.100000
	7.35kHz mode	7.350000
	14.7kHz mode	14.700000
29.4kHz mode	29.400000	
24.576	8kHz mode	8.000000
	12kHz mode	12.000000
	16kHz mode	16.000000
	24kHz mode	24.000000
	32kHz mode	32.000000
	48kHz mode	48.000000
	11.025kHz mode	11.025000
	22.05kHz mode	22.050000
	44.1kHz mode	44.100000
	7.35kHz mode	7.350000
	14.7kHz mode	14.700000
29.4kHz mode	29.400000	
	Sampling frequency that differs from sampling frequency of mode name	

Note 24 These are rounded off to six decimal places.

Table 6. Sampling Frequency at PLL mode (Reference clock is MCKI)

3. Sampling Frequency setting in PLL Mode (PLL reference clock pin: LRCK or BICK pin)

In the case of PLL2 bit = "0" and the reference clock is input to the LRCK or BICK pins, the sampling frequency is set by FS3 and FS2 bits according to Table 7.

Mode	FS3 bit	FS2 bit	FS1 bit	FS0 bit	Sampling Frequency Range
0	0	0	x	x	7.35kHz ≤ fs ≤ 12kHz
1	0	1	x	x	12kHz < fs ≤ 24kHz
2	1	0	x	x	24kHz < fs ≤ 48kHz
Others	Others				N/A

(PLL Reference: Clock: LRCK or BICK pin) (x: Don't care, N/A: Not Available)

Table 7. Sampling Frequency Setting (PLL2 bit = "0" and PMPLL bit = "1")

■ PLL Un-Lock

1. PLL Master Mode (PMPLL bit = “1”, M/S bit = “1”)

In this mode, the BICK and LRCK pins go to “L” before the PLL goes to lock state after PMPLL bit = “0” → “1” (Table 8). After the PLL is locked, a first period of LRCK and BICK may be invalid clock, but these clocks return to normal state after a period of 1/fs. When sampling frequency is changed, the BICK and LRCK pins do not output irregular frequency clocks but go to “L” by setting PMPLL bit to “0”.

PLL State	BICK pin	LRCK pin
PMPLL bit “0” → “1”	“L” Output	“L” Output
PLL Unlock (Except for the above)	Not fixed	Not fixed
PLL Lock	Table 9	1 fs Output

Table 8. Clock Operation at PLL Master Mode (PMPLL bit = “1”, M/S bit = “1”)

■ PLL Master Mode (PMPLL bit = “1”, M/S bit = “1”)

When an external clock (11.2896MHz, 12MHz, 12.288MHz, 22.5792MHz, 24MHz or 24.576MHz) is input to the XTI/MCKI pin or the crystal oscillator circuit is used, the BICK and LRCK clocks are generated by an internal PLL circuit. The BICK output frequency is selected between 32fs or 64fs, by BCKO bit (Table 9).

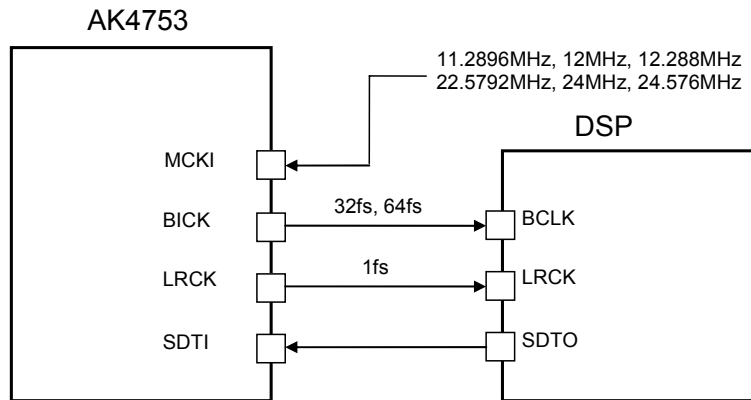

Figure 20. PLL Master Mode (External Clock Mode)

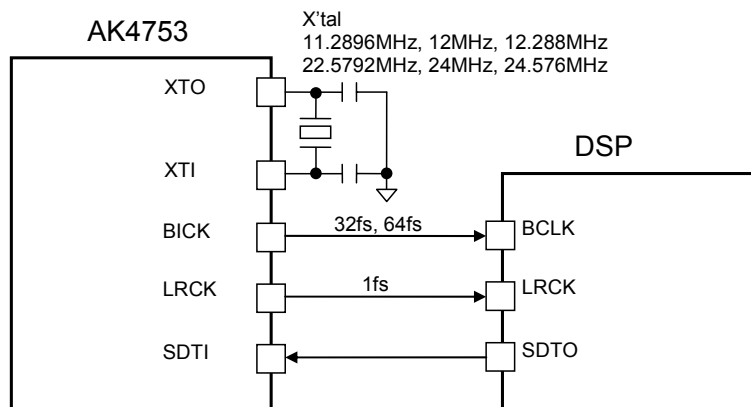

Figure 21. PLL Master Mode (X'tal Mode)

BCKO bit	BICK Output Frequency
0	32fs
1	64fs

(default)

Table 9. BICK Output Frequency at Master Mode

■ PLL Slave Mode (PMPLL bit = “1”, M/S bit = “0”)

A reference clock of PLL is selected among the input clocks to the BICK or LRCK pin. Required clock for the AK4753 is generated by an internal PLL circuit. Input frequency is selected by PLL3-0 bits (Table 4).

Sampling frequency corresponds to a range from 7.35kHz to 48kHz by changing FS3-0 bits (Table 7).

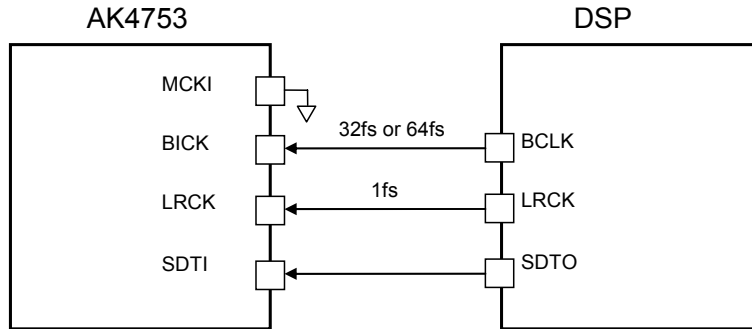

Figure 22. PLL Slave Mode (PLL Reference Clock: BICK pin)

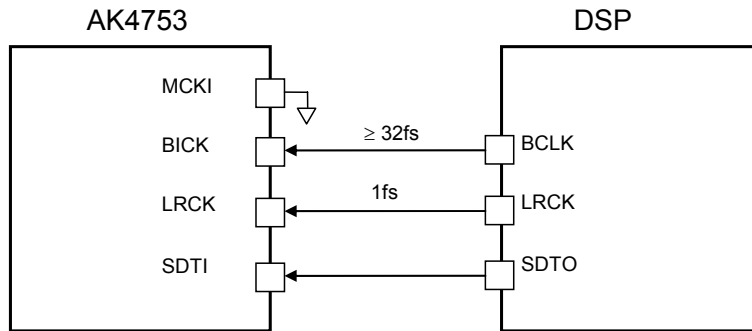

Figure 23. PLL Slave Mode (PLL Reference Clock: LRCK pin)

■ EXT Slave Mode (PMPLL bit = “0”, M/S bit = “0”)

When PMPLL bit is “0”, the AK4753 changes to EXT mode. Master clock is input from the XTI/MCKI pin, the internal PLL circuit is not operated. This mode is compatible with I/F of a normal audio CODEC. The clocks required to operate the AK4753 are MCKI (256fs, 512fs or 1024fs), LRCK (fs) and BICK (≥32fs). The master clock (MCKI) should be synchronized with LRCK. The phase between these clocks is not important. The input frequency of MCKI is selected by FS1-0 bits (Table 10).

Mode	FS3-2 bits	FS1 bit	FS0 bit	MCKI Input Frequency	Sampling Frequency Range
0	x	0	0	256fs	7.35kHz ~ 48kHz
1	x	0	1	1024fs	7.35kHz ~ 13kHz
2	x	1	0	512fs	7.35kHz ~ 26kHz
3	x	1	1	512fs	7.35kHz ~ 26kHz

(default)

Table 10. MCKI Frequency at EXT Slave Mode (PMPLL bit = “0”, M/S bit = “0”) (x: Don’t care)

The S/N of the DAC at low sampling frequencies is worse than at high sampling frequencies due to out-of-band noise. The out-of-band noise can be improved by using higher frequency of the master clock. The S/N of the DAC output through LOUT1/ROUT1 and LOUT2/ROUT2 pins is shown in Table 11.

MCKI	S/N (fs=8kHz, 20kHzLPF + A-weighted)
256fs	87 dB
512fs	96 dB
1024fs	97 dB

Table 11. Relationship between MCKI and S/N of LOUT1/ROUT1 and LOUT2/ROUT2 pins (SPC1-0 bits = "00")

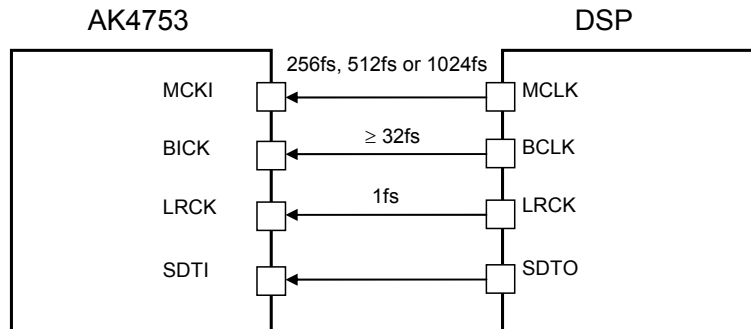

Figure 24. EXT Slave Mode

■ EXT Master Mode (PMPLL bit = "0", M/S bit = "1")

The AK4753 becomes EXT Master Mode by setting PMPLL bit = "0" or the M/S bit = "1". Master clock is input from the XTI/MCKI pin or the crystal oscillator circuit is used, the internal PLL circuit is not operated. The clock required to operate the AK4753 is XTI/MCKI (256fs, 512fs or 1024fs). The input frequency of XTI/MCKI is selected by FS1-0 bits (Table 12).

Mode	FS3-2 bits	FS1 bit	FS0 bit	XTI/MCKI Input Frequency	Sampling Frequency Range	
0	x	0	0	256fs	7.35kHz ~ 48kHz	(default)
1	x	0	1	1024fs	7.35kHz ~ 13kHz	
2	x	1	0	512fs	7.35kHz ~ 26kHz	
3	x	1	1	512fs	7.35kHz ~ 26kHz	

Table 12. XTI/MCKI Frequency at EXT Master Mode (PMPLL bit = "0", M/S bit = "1") (x: Don't care)

The S/N of the DAC at low sampling frequencies is worse than at high sampling frequencies due to out-of-band noise. The out-of-band noise can be improved by using higher frequency of the master clock. The S/N of the DAC output through LOUT1/ROUT1 and LOUT2/ROUT2 pins is shown in Table 13.

XTI/MCKI	S/N (fs=8kHz, 20kHzLPF + A-weighted)
256fs	87 dB
512fs	96 dB
1024fs	97 dB

Table 13. Relationship between XTI/MCKI and S/N of LOUT1/ROUT1 and LOUT2/ROUT2 pins (SPC1-0 bits = "00")

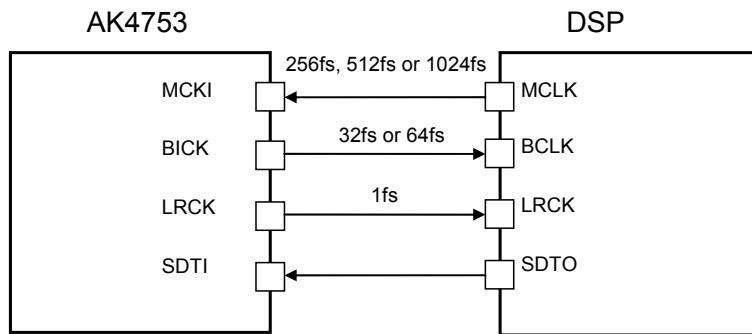

Figure 25. EXT Master Mode (External Clock Mode)

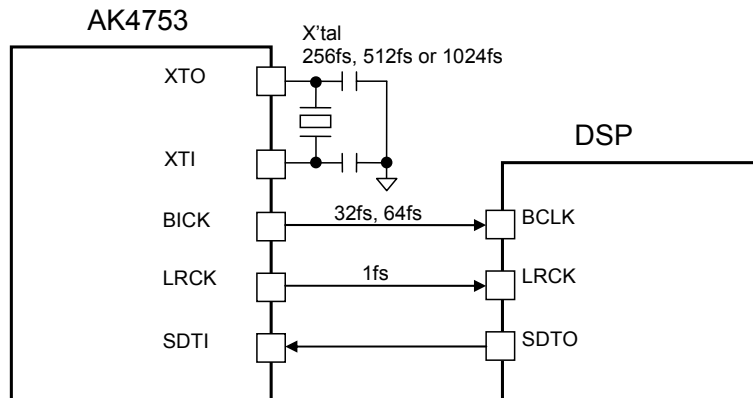

Figure 26. EXT Master Mode (X'tal Mode)

BCKO bit	BICK Output Frequency
0	32fs
1	64fs

(default)

Table 14. BICK Output Frequency at Master Mode

■ System Reset

Upon power-up, the AK4753 must be reset by bringing the PDN pin = “L”. This ensures that all internal registers reset to their initial values. The PDN pin must be set to “L” at power-up.

When PMADC bit is changed from “0” to “1”, the initialization cycle of ADC starts. The ADC outputs settle to data correspondent to the input signals after the end of initialization. The time from the input of analog signals to the output of analog signals including the initialization cycle of ADC is $1098/fs=25ms@fs=44.1kHz$.

■ Audio Interface Format

Eight types of the data formats are available and are selected by setting the DIF2-0 bits (Table 15). In all modes, the serial data is MSB first, 2’s complement format. Audio interface formats can be used in both master mode and slave mode. LRCK and BICK are output from the AK4753 in master mode, but must be input to the AK4753 in slave mode.

Mode	DIF2 bit	DIF1 bit	DIF0 bit	SDTI	LRCK	BICK	Figure
0	0	0	0	16-bit DSP Mode	H/L	$\geq 32fs$	Table 16
1	0	0	1	16-bit LSB justified	H/L	$\geq 32fs$	Figure 31
2	0	1	0	16/20/24-bit MSB justified	H/L	32fs or $\geq 48fs$	Figure 33
3	0	1	1	16/20/24-bit I ² S compatible	L/H	32fs or $\geq 48fs$	Figure 34
4	1	0	0	20-bit LSB justified	H/L	$\geq 40fs$	Figure 32
5	1	0	1	24-bit LSB justified	H/L	$\geq 48fs$	Figure 32
6	1	1	0	20-bit DSP Mode	H/L	$\geq 48fs$	Table 17
7	1	1	1	24-bit DSP Mode	H/L	$\geq 48fs$	Table 18

(default)

Table 15. Audio Interface Format

In Mode 1/2/3/4/5, the SDTI is latched on the rising edge (“↑”) of BICK.

In Modes 0/6/7 (DSP mode), the audio I/F timing is changed by BCKP and MSBS bits.

When BCKP bit = “0”, the SDTI is latched on the falling edge (“↓”) of BICK.

When BCKP bit = “1”, the SDTI is latched on the rising edge (“↑”) of BICK.

MSBS bit can shift the position of the MSB data of SDTI to the position of the half cycle of the BICK.

DIF2	DIF1	DIF0	MSBS	BCKP	Audio Interface Format	Figure
0	0	0	0	0	MSB data of SDTI is latched on the falling edge (“↓”) of the first BICK after the rising edge (“↑”) of LRCK.	Figure 27 (default)
			0	1	MSB data of SDTI is latched on the rising edge (“↑”) of the first BICK after the rising edge (“↑”) of LRCK.	Figure 28
			1	0	MSB data of SDTI is latched on the falling edge (“↓”) of the first BICK after the falling edge (“↓”) of the first BICK after the rising edge (“↑”) of LRCK.	Figure 29
			1	1	MSB data of SDTI is latched on the rising edge (“↑”) of the first BICK after the rising edge (“↑”) of the first BICK after the rising edge (“↑”) of LRCK.	Figure 30

Table 16. Audio Interface Format in Mode 0

DIF2	DIF1	DIF0	MSBS	BCKP	Audio Interface Format	Figure
1	1	0	0	0	MSB data of SDTI is latched on the falling edge (“↓”) of the first BICK after the rising edge (“↑”) of LRCK.	Figure 35 (default)
			0	1	MSB data of SDTI is latched on the rising edge (“↑”) of the first BICK after the rising edge (“↑”) of LRCK.	Figure 36
			1	0	MSB data of SDTI is latched on the falling edge (“↓”) of the first BICK after the falling edge (“↓”) of the first BICK after the rising edge (“↑”) of LRCK.	Figure 37
			1	1	MSB data of SDTI is latched on the rising edge (“↑”) of the first BICK after the rising edge (“↑”) of the first BICK after the rising edge (“↑”) of LRCK.	Figure 38

Table 17. Audio Interface Format in Mode 6

DIF2	DIF1	DIF0	MSBS	BCKP	Audio Interface Format	Figure
1	1	1	0	0	MSB data of SDTI is latched on the falling edge (“↓”) of the first BICK after the rising edge (“↑”) of LRCK.	Figure 39 (default)
			0	1	MSB data of SDTI is latched on the rising edge (“↑”) of the first BICK after the rising edge (“↑”) of LRCK.	Figure 40
			1	0	MSB data of SDTI is latched on the falling edge (“↓”) of the first BICK after the falling edge (“↓”) of the first BICK after the rising edge (“↑”) of LRCK.	Figure 41
			1	1	MSB data of SDTI is latched on the rising edge (“↑”) of the first BICK after the rising edge (“↑”) of the first BICK after the rising edge (“↑”) of LRCK.	Figure 42

Table 18. Audio Interface Format in Mode 7

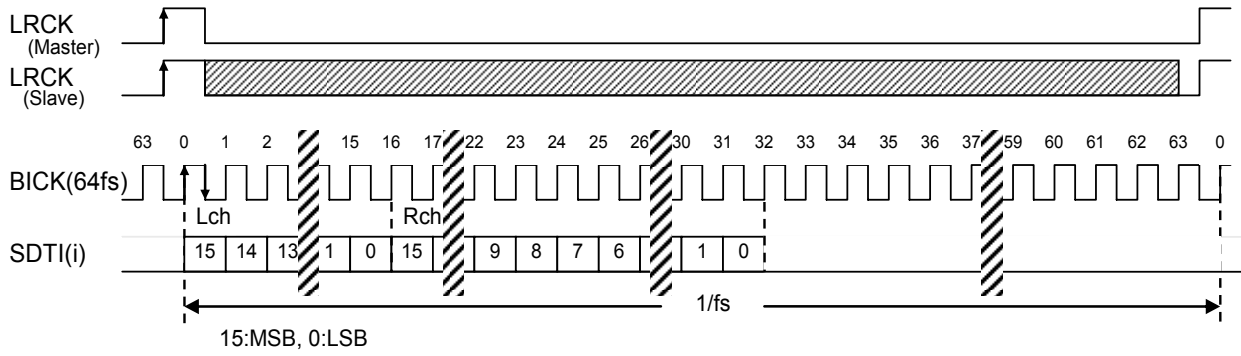

Figure 27. Mode 0 Timing (BCKP bit=“0”, MSBS bit=“0”)

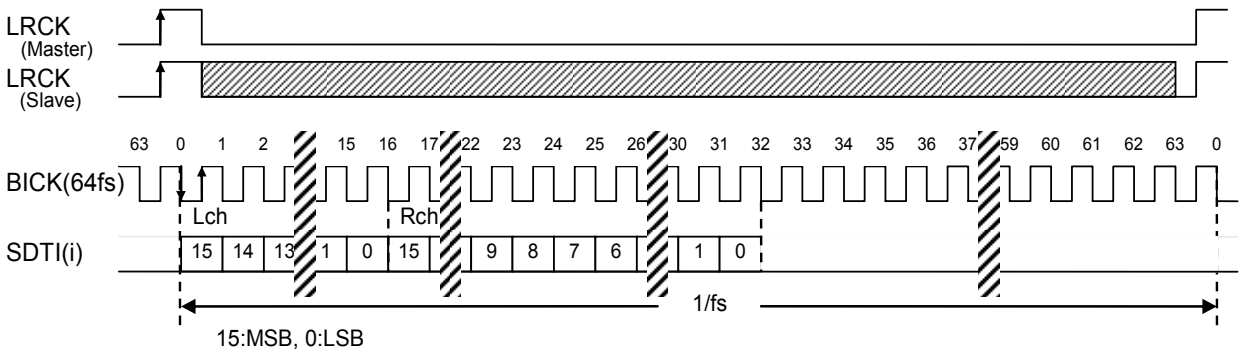

Figure 28. Mode 0 Timing (BCKP bit=“1”, MSBS bit=“0”)

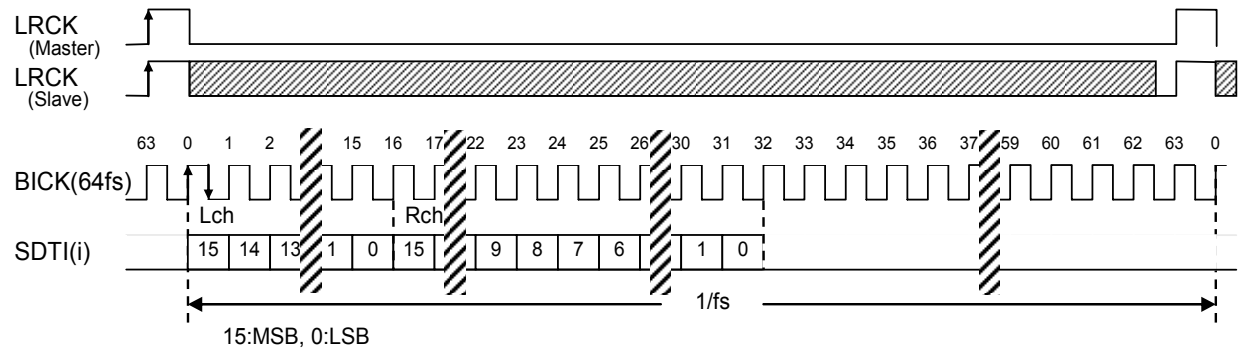

Figure 29. Mode 0 Timing (BCKP bit=“0”, MSBS bit=“1”)

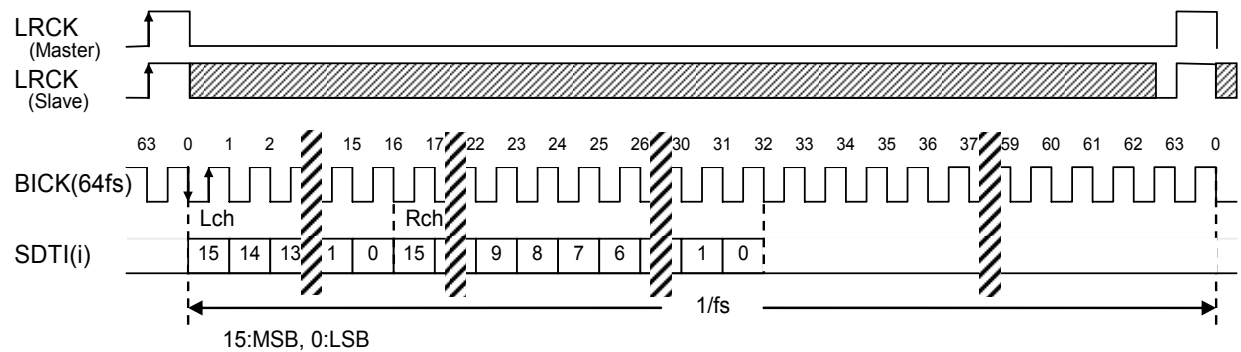

Figure 30. Mode 0 Timing (BCKP bit=“1”, MSBS bit=“1”)

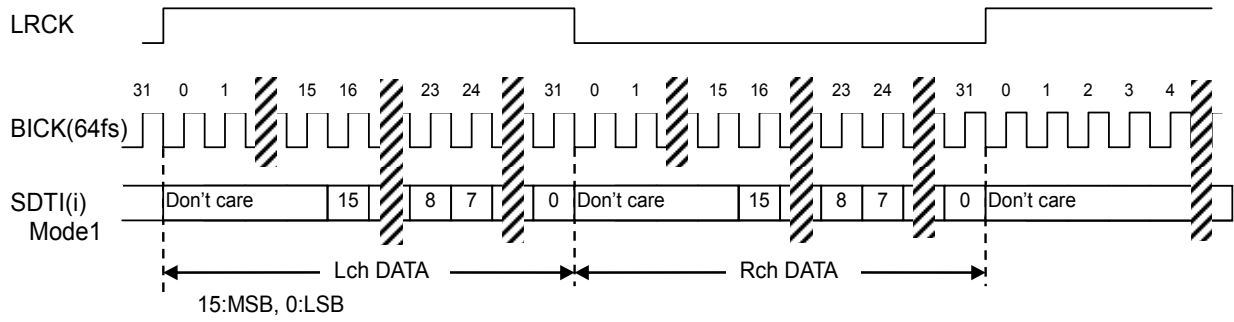

Figure 31. Mode 1 Timing

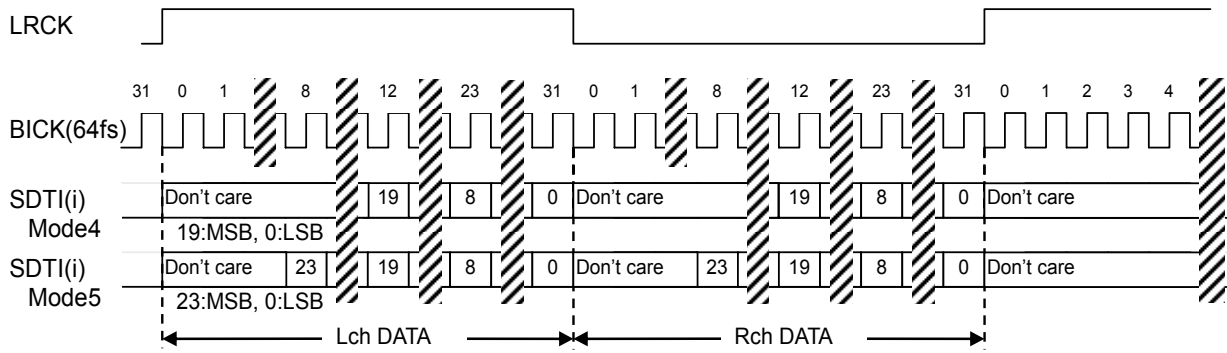

Figure 32. Mode 4/5 Timing

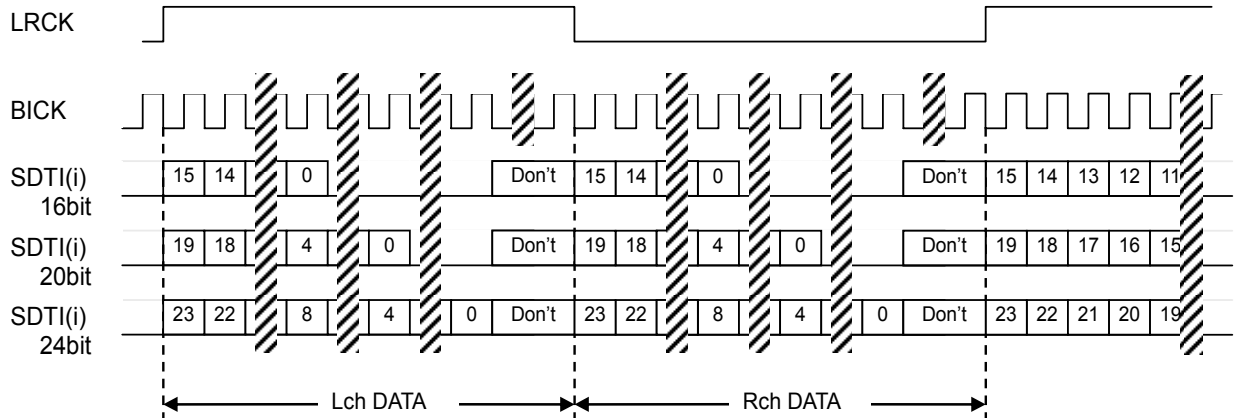

Figure 33. Mode 2 Timing

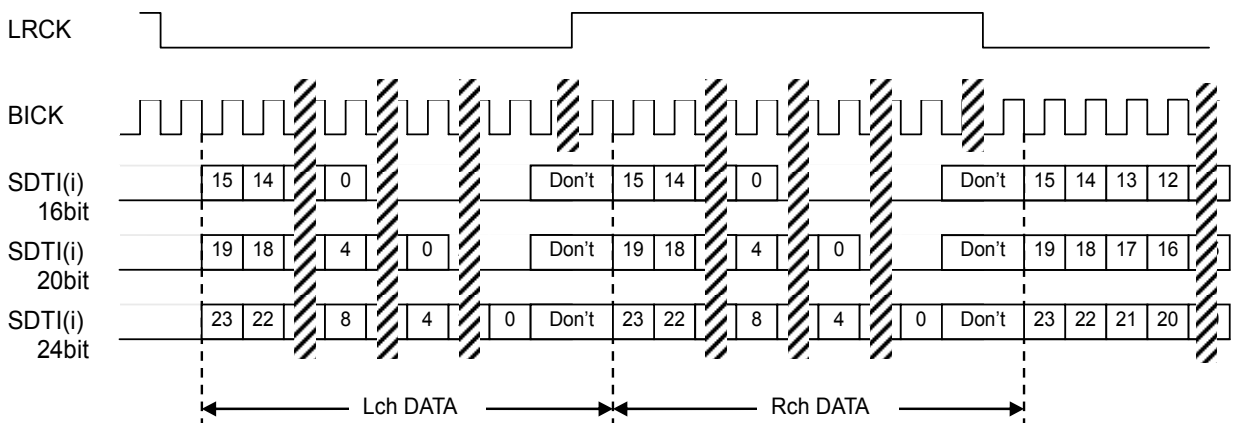

Figure 34. Mode 3 Timing

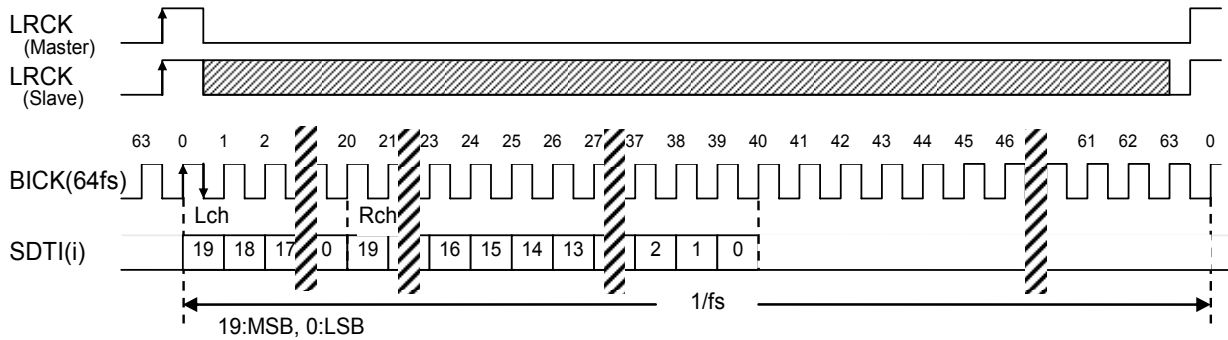

Figure 35. Mode 6 Timing (BCKP bit=“0”, MSBS bit=“0”)

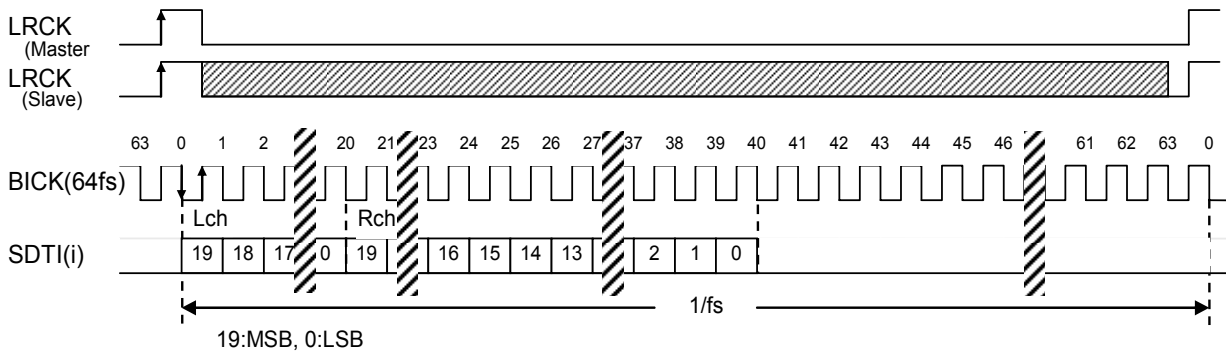

Figure 36. Mode 6 Timing (BCKP bit=“1”, MSBS bit=“0”)

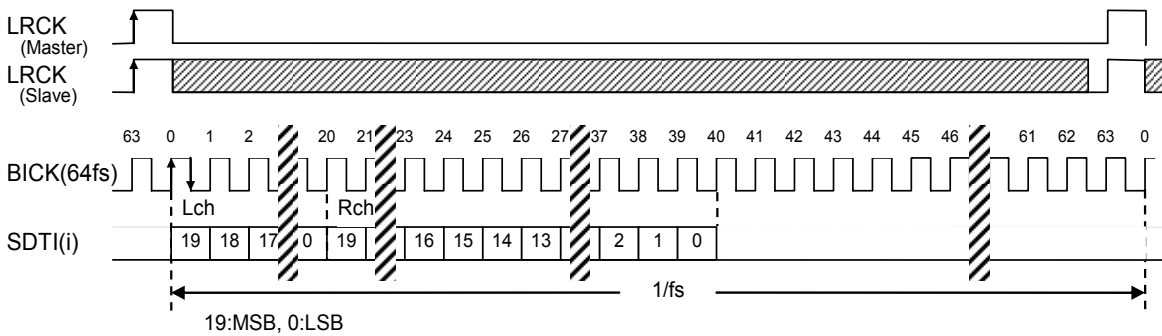

Figure 37. Mode 6 Timing (BCKP bit=“0”, MSBS bit=“1”)

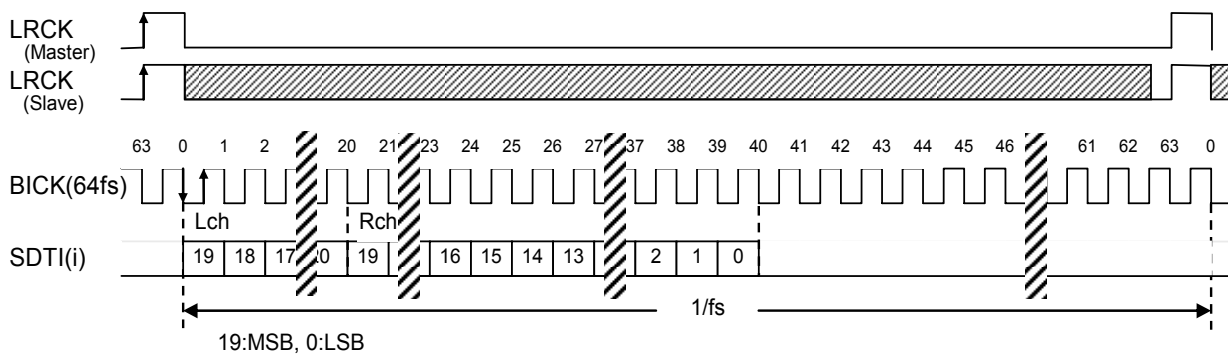

Figure 38. Mode 6 Timing (BCKP bit=“1”, MSBS bit=“1”)

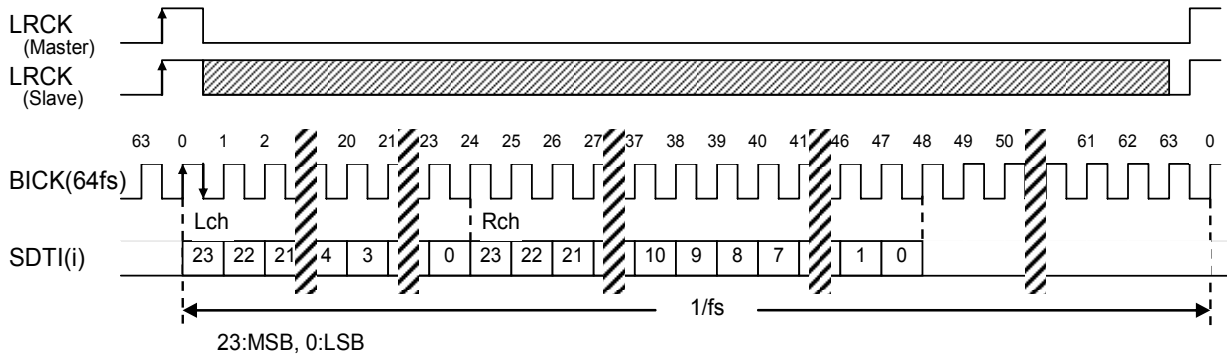

Figure 39. Mode 7 Timing (BCKP bit=“0”, MSBS bit=“0”)

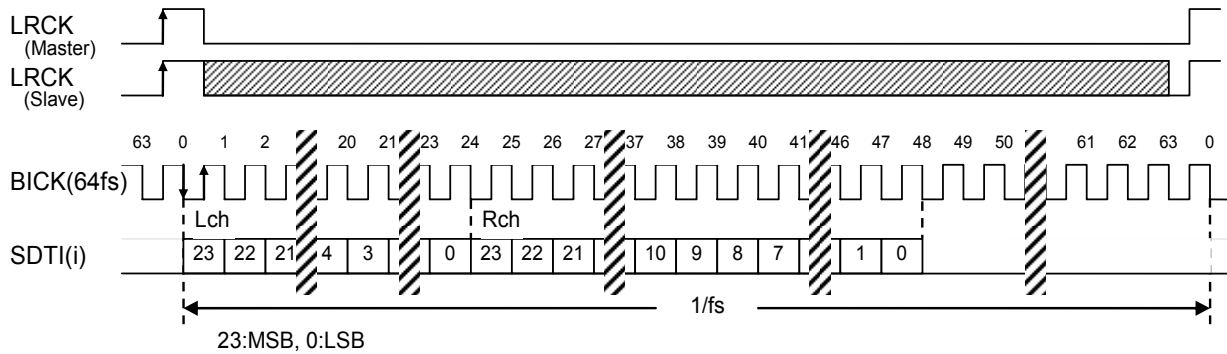

Figure 40. Mode 7 Timing (BCKP bit=“1”, MSBS bit=“0”)

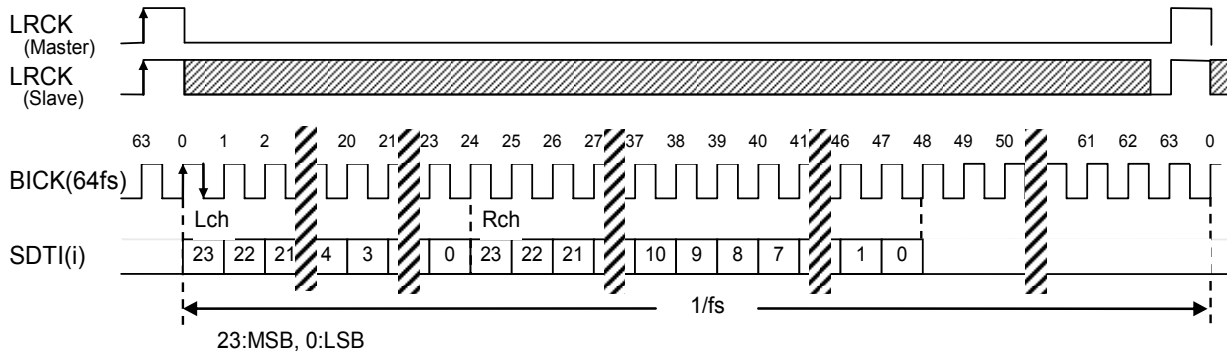

Figure 41. Mode 7 Timing (BCKP bit=“0”, MSBS bit=“1”)

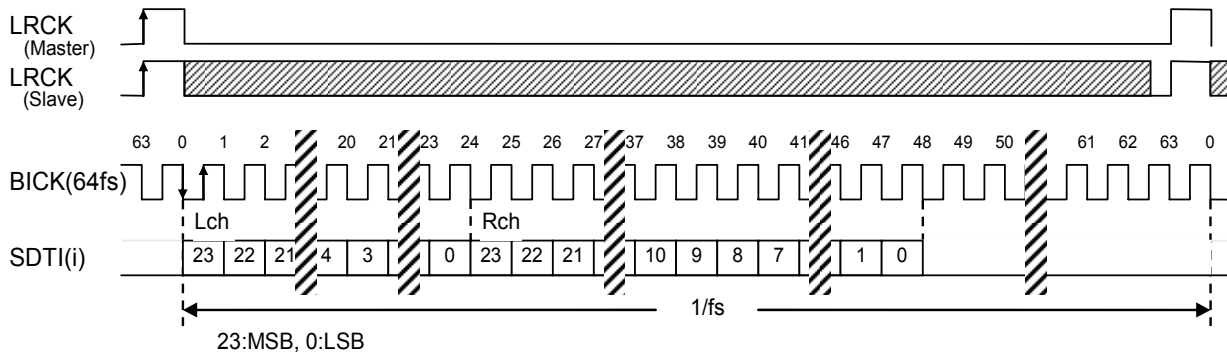

Figure 42. Mode 7 Timing (BCKP bit=“1”, MSBS bit=“1”)

■ DSP Input Signals Setting

The AK4753 has three input sources for DSP. The inputs of digital, analog and mix signals can be changed by SEL1-0 bits. In the initialization, the setting is SEL1-0 bits = “00” (Analog Input).

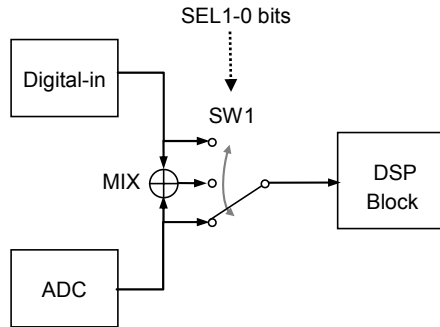

Figure 43. DSP Input source

SEL1 bit	SEL0 bit	DSP input source	Note
0	0	Analog	Default
0	1	Digital	
1	0	MIX	(Analog source)/2 + Digital source/2
1	1	N/A	

Table 19. DSP Input Setting (N/A: Not Available)

■ Bypass Mode

The AK4753 has a BYPASS pin for the DSP bypass mode. When the BYPASS pin is “L”, the DSP blocks are enabled. When the BYPASS pin is “H”, the DSP blocks are disabled and the DATT outputs are skipped over the DSP blocks to the DAC.

BYPASS pin	Mode
H	DSP Bypass Mode
L	Normal Operation

Table 20. Bypass Mode

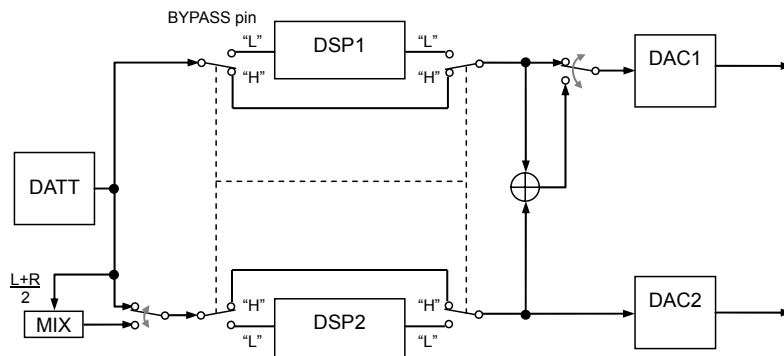

Figure 44. Bypass Mode

<Bypass Mode Control Sequence>

The AK4753 has a mute control output pin (MUTEN pin) for external speaker amplifier. In order to prevent a pop noise through the AK4753, the MTUEN pin is connected to a mute pin or a standby pin of the external speaker amplifier.

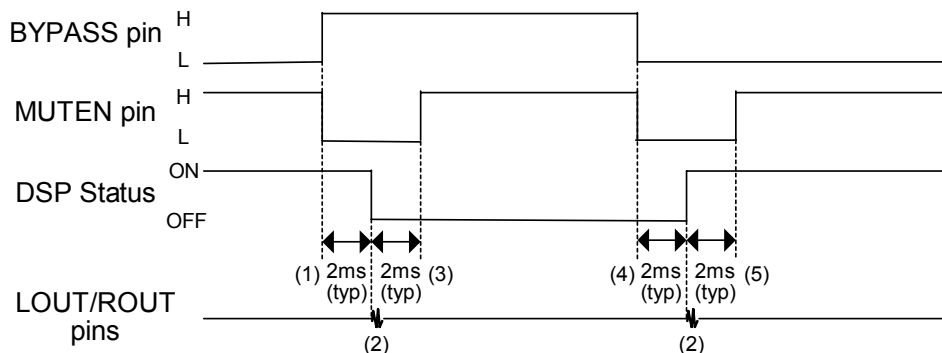

Figure 45. Bypass Mode Control Sequence

- (1) When the BYPASS pin turns "H", the MUTEN pin is set "L".
- (2) Pop noise occurs after 2ms (@fs=48kHz), when the DSP bypass mode is changed.
- (3) DSP bypass mode is changed, then the MUTEN pin is set "H" after 2ms (@fs=48kHz).
- (4) When the BYPASS pin turns "L", the MUTEN pin is set "L".
- (5) DSP bypass mode is changed, then the MUTEN pin is set "H" after 2ms (@fs=48kHz).

■ Audio DAC outputs Configurations

The AK4753 has three modes as Audio DAC Configurations; Stereo Mode, 2.1-channels Mode and 4-channels Mode. Each mode is selected by SPC1-0 bits. In the initialization, the setting of the SPC1-0 bits is “00” (Stereo Mode).

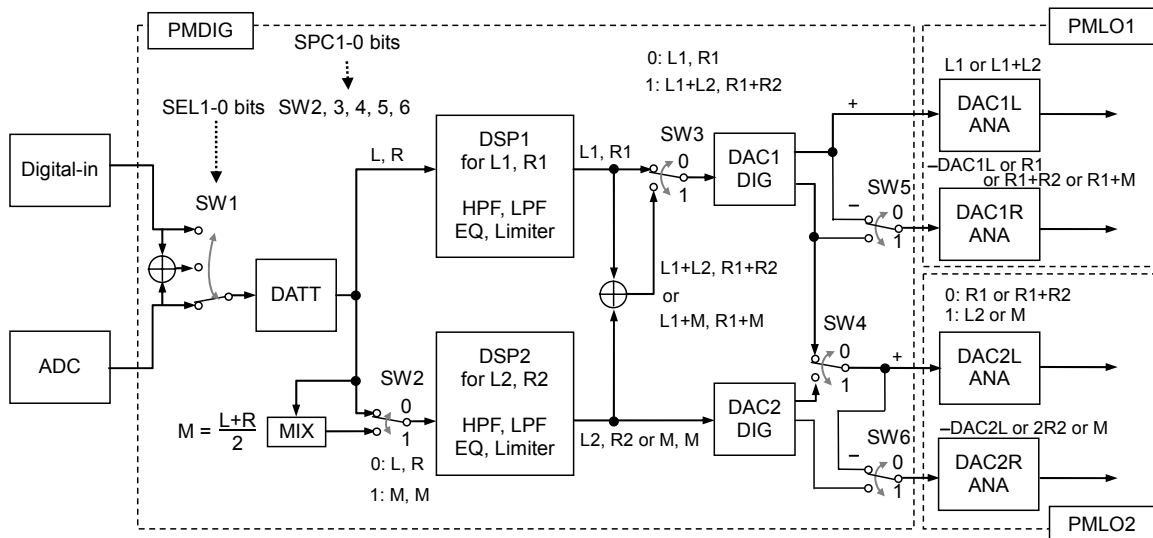

Figure 46. Block Diagram of Signal Path

1. Stereo Mode (SPC1-0 bits = "00": SW2 = "0", SW3 = "0", SW4 = "0", SW5 = "0", SW6 = "0")

Table 21 shows the signal status and output condition when SPC1-0 bits = "00". This output configuration is suitable for a traditional stereo speaker system. Refer to the Figure 55 for functions and signal paths of the DSP block.

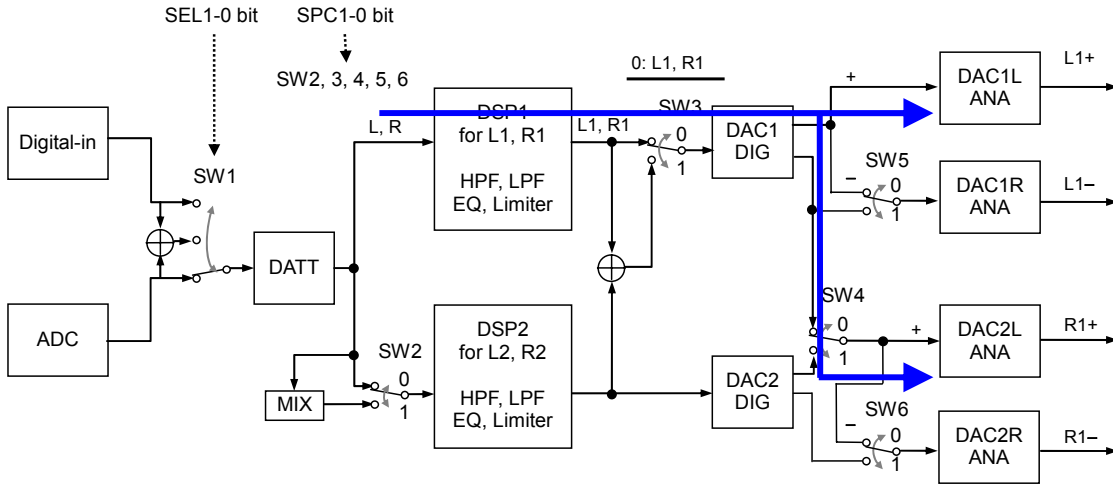

Figure 47. Block Diagram for Signal Path (SPC1-0 bits = "00")

Output Setting		Signal and Output Block				Output
SPC1 bit	SPC0 bit	Audio Signal	Polarity	DAC	Pin	
0 (default)	0 (default)	L1	+	DAC1L	LOUT+	L1+
			-	DAC1R	LOUT-	L1-
		R1	+	DAC2L	ROUT+	R1+
			-	DAC2R	ROUT-	R1-

Table 21. Stereo Mode Setting and Output Signal Details

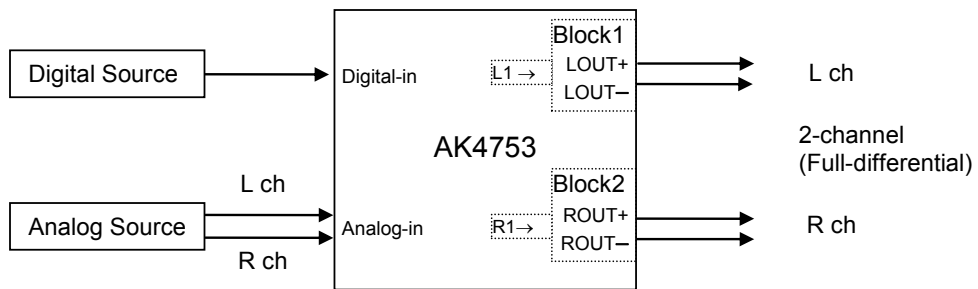

Figure 48. 2-channels (Stereo) mode

2. Stereo mode (HPF, LPF individual mode)

(SPC1-0 bits = "01": SW2 = "0", SW3 = "1", SW4 = "0", SW5 = "0", SW6 = "0")

Table 22 shows the signal status and output condition when SPC1-0 bits = "01". This output configuration is suitable for a stereo speaker system which needs individual effects of DSP. L1(Hi), L2(Lo), R1 (Hi) and R2 (Lo) is an example of the DSP setting. L1(Hi), R1(Hi) are signals which were after HPF in DSP1. And L2(Lo), R2(Lo) are signals which were applied LPF in DSP2. Refer to the Figure 55 for functions and signal paths of the DSP block.

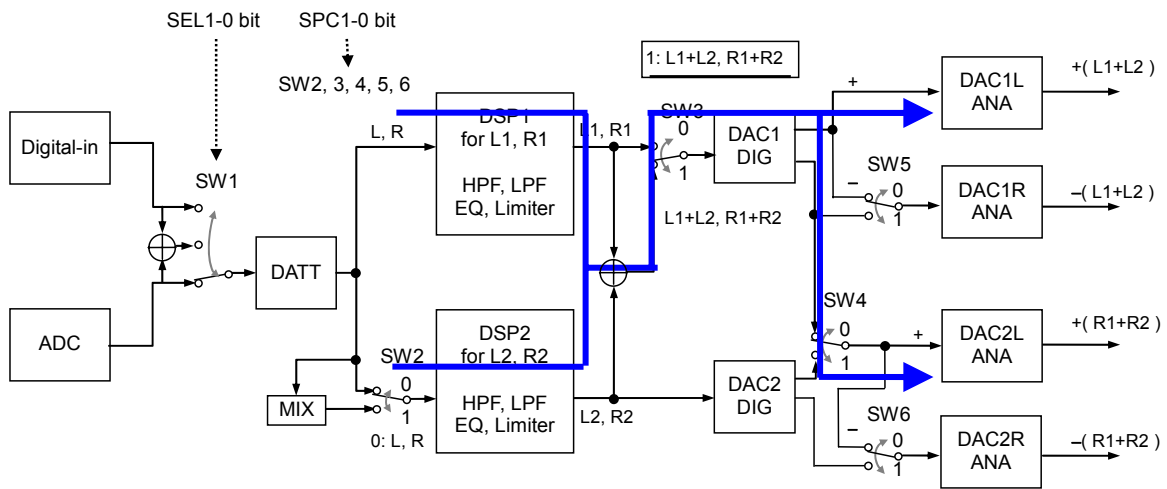

Figure 49. Block Diagram for Signal Path (SPC1-0 bits = "01")

Output Setting		Signal and Output Block				Output
SPC1 bit	SPC0 bit	Audio Signal	Polarity	DAC	Pin	
0	1	L1(Hi)+L2(Lo)	+	DAC1L	LOUT+	L+
			-	DAC1R	LOUT-	L-
		R1(Hi)+R2(Lo)	+	DAC2L	ROUT+	R+
			-	DAC2R	ROUT-	R-

Table 22. Stereo Mode Setting and Output Signal Status Details

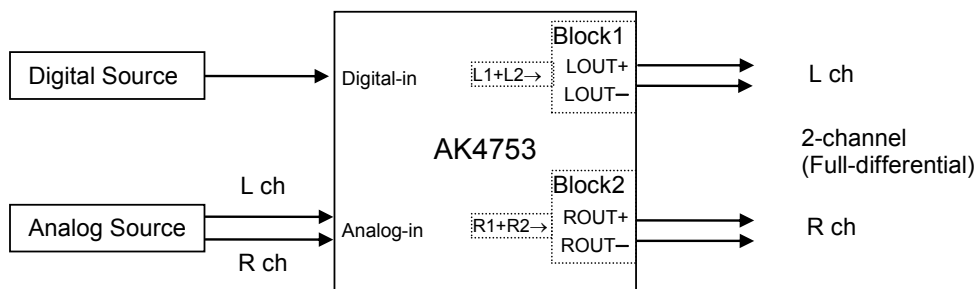

Figure 50. 2-channels (Stereo) Mode

3. 2.1-channels mode (SPC1-0 bits = "10": SW2 = "1", SW3= "0", SW4= "1", SW5= "1", SW6= "0")

Table 23 shows the signal status and output condition when SPC1-0 bits = "10". This output configuration is suitable for a 2.1 channel application with a subwoofer. SW output is an example of the DSP setting. L1(Hi), R1(Hi) are signals which were after HPF in DSP1. M(Lo) is signal which was after LPF in DSP2. Refer to the Figure 55 for functions and signal paths of the DSP block.

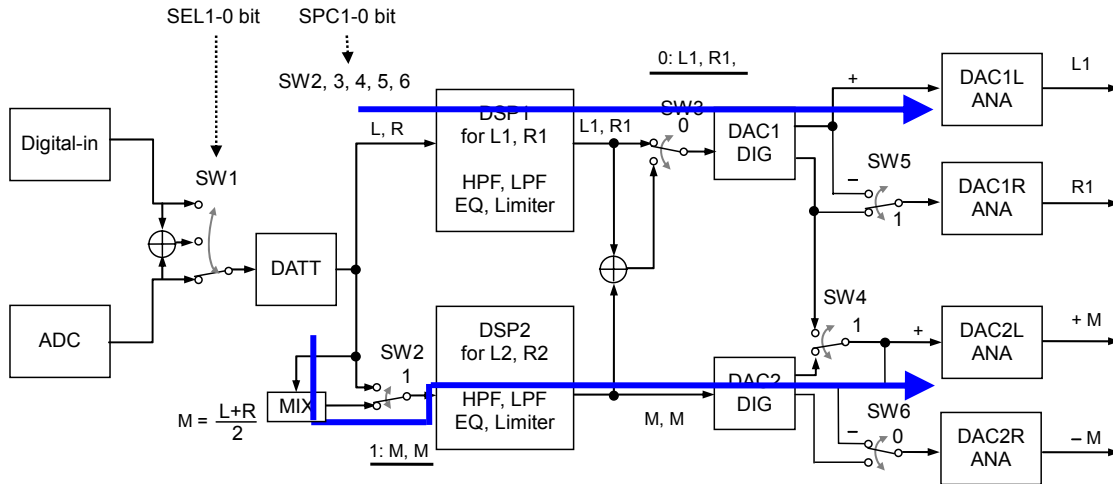

Figure 51. Block Diagram for Signal Path (SPC1-0 bits = "10")

Output Setting		Signal and Output Block				Output
SPC1 bit	SPC0 bit	Audio Signal	Polarity	DAC	Pin	
1	0	L1(Hi)+R1(Hi)	non	DAC1L	LOUT1	L
			non	DAC1R	ROUT1	R
		M(Lo)	+	DAC2L	LOUT2	SW+
			-	DAC2R	ROUT2	SW-

Table 23. 2.1-channels mode setting and Output Signal Status Details (SW: Subwoofer, M: Mono Mix)

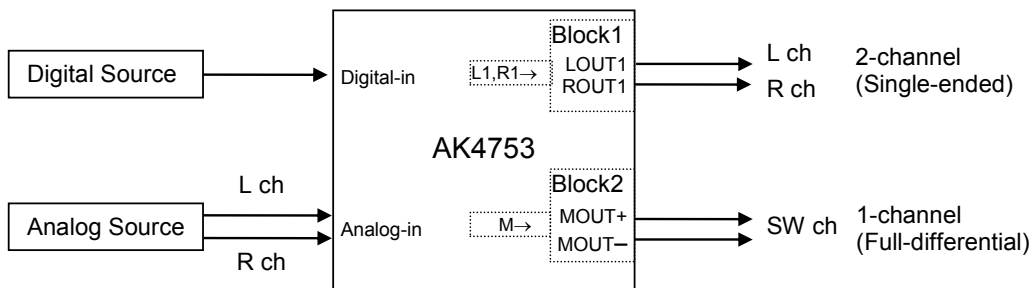

Figure 52. 2.1-channels Mode (SW: Subwoofer, M: Mono Mix)

4. 4-channels mode (SPC1-0 bits = "11": SW2 = "0", SW3="0", SW4="1", SW5="1", SW6="1")

Table 24 shows the signal status and output condition when SPC1-0 bits = "11". This output configuration is suitable for a Two-Way Speaker System.

L1(Hi), L2(Lo), R1 (Hi) and R2 (Lo) is an example of the DSP setting. L1(Hi), R1(Hi) are signals which were after HPF in DSP1. L2(Lo) and R2(Lo) are signals which were after LPF in DSP2. Refer to the Figure 55 for functions and signal paths of the DSP block.

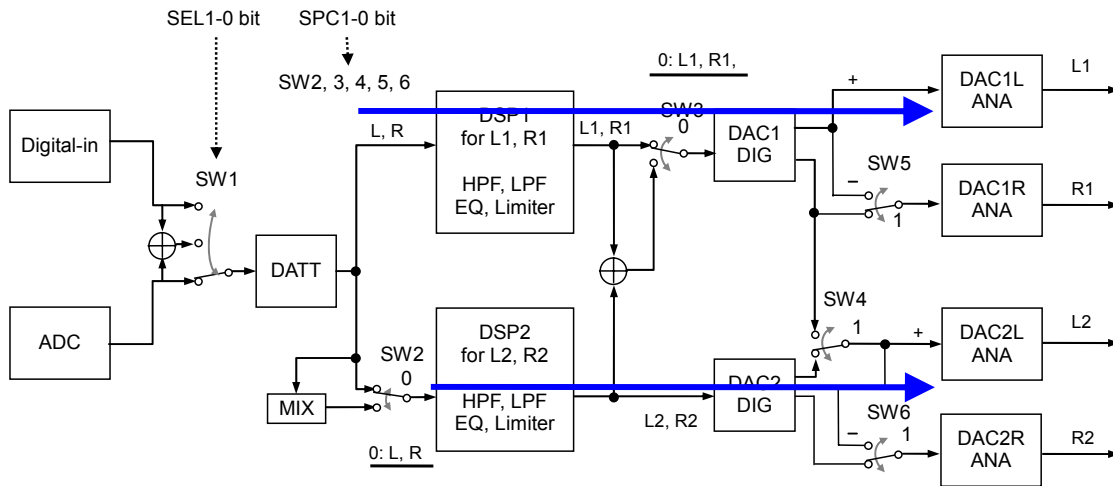

Figure 53. Block Diagram for Signal Path (SPC1-0 bits = "11")

Output Setting		Signal and Output Block				Signal
SPC1 bit	SPC0 bit	Audio Signal	Polarity	DAC	Pin	
1	1	L1(Hi)+R1(Hi)	non	DAC1L	LOUT1	L(Hi)
			non	DAC1R	ROUT1	R(Hi)
		L2(Lo)+R2(Lo)	non	DAC2L	LOUT2	L(Lo)
			non	DAC2R	ROUT2	R(Lo)

Table 24. 4-channels Mode Setting and Output Signal Status Details (Hi: High Frequency Signal, Lo: Low Frequency Signal)

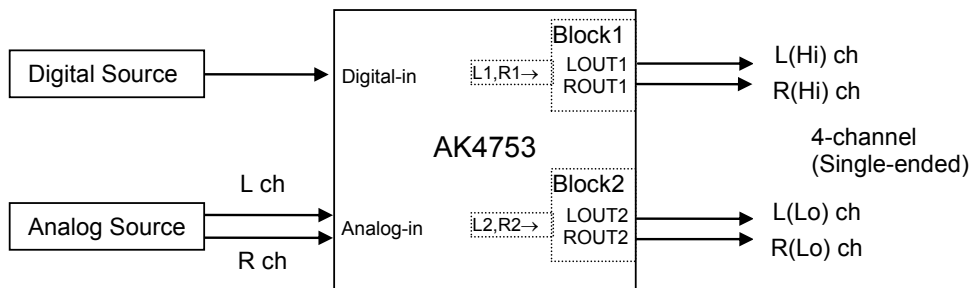

Figure 54. 4-channels Mode and Output Bridge Configuration (Example: Hi= High Frequency Signal, Lo= Low Frequency Signal are for Two-Way Speaker system.)

■ DSP Functions and Signal Path

The AK4753 has two DSP circuit blocks and one digital volume circuit (DATT). Each DSP block can be set individually for HPF/LPF, Five Biquads EQ, Pre-Gain, Limiter, and Post-Gain.

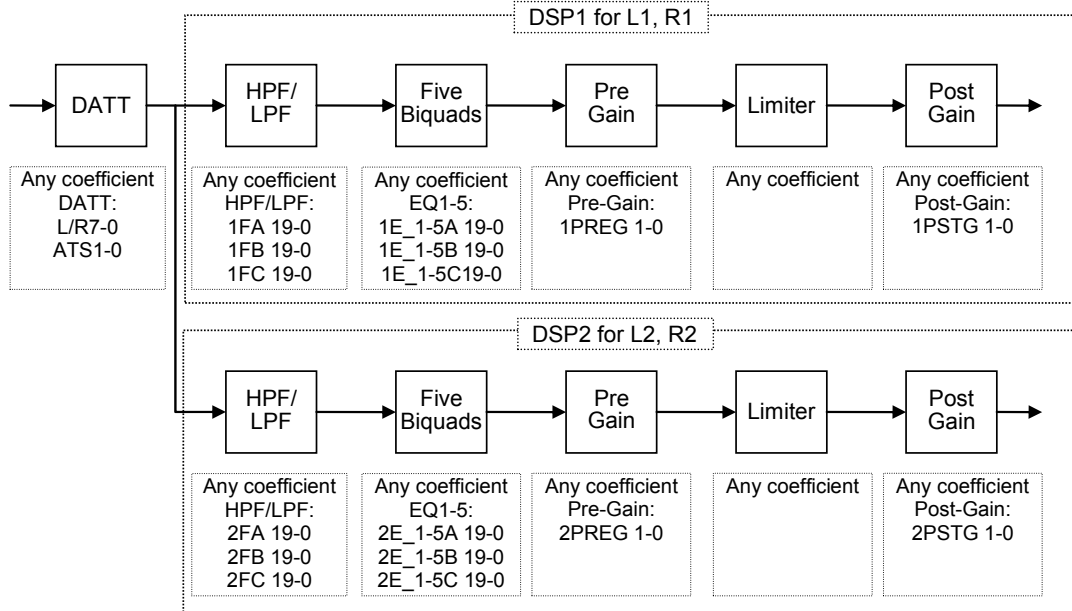

Figure 55. DSP Functions and Signal Path

Refer to the each description of the function for detail settings. Available effects of the DSP are shown in [Table 29](#). Those effects in each function block of the DSP1 and DSP2 are set together, “L1 and R1” or “L2 and R2”.

■ Digital Volume and Gain Control

The AK4753 has three volume controls as gain setting of the amplifier outputs. Digital volume control is the general volume to adjust the output signal level in normal operation. Pre-Gain and Post-Gain are for gain setting of the signal level in the signal path.

1. Digital Volume (DATT)

The Ak4753 has a built-in channel independent digital volume (DATT) with 256 levels in 0.5dB steps including MUTE. The transition time between the set levels by L7-0 bits (R7-0 bits) can be set by DVTM bit. When DVTM bit = "0" (Table 26), the transition time from 0dB(00H) to MUTE(FFH) is 1024/fs (21.3ms@fs=48kHz). When the PDN pin is set to "L", the volume level is initialized to MUTE(FFH). The transition between the set levels is soft transition. Therefore a switching noise does not occur within the transition. When the PMSAR bit = "1", the volume and gain follows the SAR value and the register setting of DATT (L/R7-0 bits) is invalid.

L/R7-0 bits	Attenuation Level
00H	0dB
01H	-0.5dB
02H	-1.0dB
03H	-1.5dB
⋮	⋮
FDH	-126.5dB
FEH	-127.0dB
FFH	MUTE ($-\infty$)

(default)

Table 25. Digital Volume ATT Value

DVTM bit	ATT speed	
	0dB to MUTE	1 step
0	1024/fs	4/fs
1	256/fs	1/fs

(default)

Table 26. Transition Time among ATT7-0 Setting Values of the Digital Volume

2. Pre-Gain

The AK4753 has the four steps volume before a limiter circuit. The volume levels of L channel and R channel are in common in one DSP block, but levels between two DSP blocks are independent. Volume levels are set by 1PREG1-0 and 2PREG1-0 bits (Table 27). When the set level is changed, a switching noise occurs because the volume level is re-written by the register directory.

1PREG1-0 bits 2PREG1-0 bits	GAIN(dB)	Step
00	0.0	6.0dB
01	+6.0	
10	+12.0	
11	+18.1	

(default)

Table 27. Pre-Gain Setting

3. Post-Gain

The AK4753 has the four steps volume after the limiter circuit. The volume levels of L channel and R channel are in common in one DSP block, but those levels between two DSP blocks are independent. Volume levels are set by 1PSTG1-0 and 2PSTG1-0 bits (Table 28). When the set level is changed, a switching noise occurs because the volume level is re-written by the register directory.

1PSTG1-0 bits 2PSTG1-0 bits	GAIN(dB)
00	0.0
01	+3.5
10	+6.0
11	+8.0

(default)

Table 28. Post-Gain Setting

■ DSP Block

Available setting of HPF, LPF and 5-programmable Biquads in Stereo mode, 2.1 channel mode and 4-channel mode are shown in Table 29. HPF, LPF and 5EQ in Table 29 should be set carefully according to the frequency response of the speaker which is actually used. The parameter of each setting can be set freely for application requests.

Mode	Output			DSP setting channel	Available setting channel					
	Channel	Pin	Signal		HPF	LPF	5 EQ	Pre-Gain	Limiter	Post-Gain
Stereo	L ch	Out1	L+	DSP1	L1	L1	L1	L1	L1	L1
		Out2	L-							
	R ch	Out3	R+	DSP1	R1	R1	R1	R1	R1	R1
		Out4	R-							
Stereo (HPF, LPF)	L ch	Out1	L(Hi)+	DSP1	L1	(L1)	L1	L1	L1	L1
			L(Lo)+	DSP2	(L2)	L2	L2	L2	L2	L2
		Out2	L(Hi)-	DSP1	L1	(L1)	L1	L1	L1	L1
			L(Lo)-	DSP2	(L2)	L2	L2	L2	L2	L2
	R ch	Out3	R(Hi)+	DSP1	R1	(R1)	R1	R1	R1	R1
			R(Lo)+	DSP2	(R2)	R2	R2	R2	R2	R2
		Out4	R(Hi)-	DSP1	R1	(R1)	R1	R1	R1	R1
			R(Lo)-	DSP2	(R2)	R2	R2	R2	R2	R2
2.1-channels	L ch	Out1	L(Hi)	DSP1	L1	(L1)	L1	L1	L1	L1
	R ch	Out2	R(Hi)	DSP1	R1	(R1)	R1	R1	R1	R1
	SW ch	Out3	M(Lo)+	DSP2	(M)	M	M	M	M	M
		Out4	M(Lo)-							
4-channels	L (Hi) ch	Out1	L1(Hi)	DSP1	L1	(L1)	L1	L1	L1	L1
	R (Hi) ch	Out2	R1(Hi)	DSP1	R1	(R1)	R1	R1	R1	R1
	L (Lo) ch	Out3	L2(Lo)	DSP2	(L2)	L2	L2	L2	L2	L2
	R (Lo) ch	Out4	R2(Lo)	DSP2	(R2)	R2	R2	R2	R2	R2

Table 29. Available Settings for DSP and Signal Path of Each Speaker Configuration (SW: Subwoofer, M: Mono Mix)

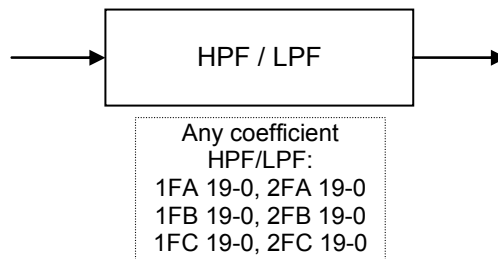

Figure 56. Digital HPF/LPF

■ HPF and LPF Coefficients

HPF and LPF are controlled by 1FILSEL and 2FILSEL bits. When 1FILSEL and 2FILSEL bits=“1”, this block works as a HPF. When 1FILSEL and 2FILSEL bits=“0”, this block works as a LPF. ON/OFF switching of this block can be controlled by 1FILEN and 2FILEN bits. When the block of HPF/LPF becomes OFF mode by 1FILEN and 2FILEN bits=“0”, the audio data passes this block by 0dB gain. The setting of the coefficients should be made when the AK4753 is in the state that 1FILEN bit=2FILEN bit=“0”.

fs: Sampling frequency
fc: Cutoff frequency (-6dB point)

Register setting (Note 25)

1FA19-0, 2FA19-0 bits = A
1FB19-0, 2FB19-0 bits = B
1FC19-0, 2FC19-0 bits = C

1FILSEL bit 2FILSEL bit	“0” (LPF)	“1” (HPF)
A	$\frac{1}{1 + 2 \cos\left(\frac{1}{4} \pi\right) / \tan\left(\frac{\pi fc}{fs}\right) + 1 / \tan^2\left(\frac{\pi fc}{fs}\right)}$	$\frac{1 / \tan^2\left(\frac{\pi fc}{fs}\right)}{1 + 2 \cos\left(\frac{1}{4} \pi\right) / \tan\left(\frac{\pi fc}{fs}\right) + 1 / \tan^2\left(\frac{\pi fc}{fs}\right)}$
B	$2 \times \frac{1 - 1 / \tan^2\left(\frac{\pi fc}{fs}\right)}{1 + 2 \cos\left(\frac{1}{4} \pi\right) / \tan\left(\frac{\pi fc}{fs}\right) + 1 / \tan^2\left(\frac{\pi fc}{fs}\right)}$	
C	$\frac{1 - 2 \cos\left(\frac{1}{4} \pi\right) / \tan\left(\frac{\pi fc}{fs}\right) + 1 / \tan^2\left(\frac{\pi fc}{fs}\right)}{1 + 2 \cos\left(\frac{1}{4} \pi\right) / \tan\left(\frac{\pi fc}{fs}\right) + 1 / \tan^2\left(\frac{\pi fc}{fs}\right)}$	
Transfer function	$H(z) = \left(A \frac{1 + 2z^{-1} + z^{-2}}{1 + Bz^{-1} + Cz^{-2}} \right)^2$	$H(z) = \left(A \frac{1 - 2z^{-1} + z^{-2}}{1 + Bz^{-1} + Cz^{-2}} \right)^2$

The cutoff frequency should be set within the range as follows.

HPF: $1.042 \times 10^{-3} \leq fc/fs \leq 0.24$ $fc_{min} = 50\text{Hz}$ $fc_{max} = 11.5\text{kHz @ } fs=48\text{kHz}$
 LPF: $5.208 \times 10^{-3} \leq fc/fs \leq 0.24$ $fc_{min} = 250\text{Hz}$ $fc_{max} = 11.5\text{kHz @ } fs=48\text{kHz}$

Other fs settings lower than above for LPF are shown in Table 30.

fc/fs	fc(@fs=48kHz)	A(dec)	B(dec)	C(dec)
1.921×10^{-3}	94.8Hz	5	-259845	128793
2.137×10^{-3}	103.9Hz	6	-259624	128576
2.333×10^{-3}	112.0Hz	7	-259426	128382
⋮	⋮	⋮	⋮	⋮
⋮	⋮	⋮	⋮	⋮
5.208×10^{-3}	250Hz	34	-256079	125144

Table 30. Low Frequency Band Setting of LPF

■ Five Programmable Biquads

This block can be used as an equalizer or notch filter. 5-band equalizer (EQ1, EQ2, EQ3, EQ4 and EQ5) is ON/OFF independently by EQ1, EQ2, EQ3, EQ4 and EQ5 bits. When the equalizer is OFF, the audio data passes this block by 0dB gain. E1A19-0, E1B19-0 and E1C19-0 bits set the coefficient of EQ1. E2A19-0, E2B19-0 and E2C19-0 bits set the coefficient of EQ2. E3A19-0, E3B19-0 and E3C19-0 bits set the coefficient of EQ3. E4A19-0, E4B19-0 and E4C19-0 bits set the coefficient of EQ4. E5A19-0, E5B19-0 and E5C19-0 bits set the coefficient of EQ5. EQx (x=1~5) coefficient should be set when EQx bit = "0" or PMDAC bit = "0". When the SA2 bit = "1", K₁ gain must be set to "1" for the DSP channel selected by the SA2SEL bit.

- fs: Sampling frequency
- f₀₁ ~ f₀₅: Center frequency
- fb₁ ~ fb₅: Band width where the gain is 3dB different from center frequency
- K₁ ~ K₅ : Gain (-1 ≤ K_n < 3)

Register setting (Note 25)

- EQ1: E1A19-0 bits =A₁, E1B19-0 bits =B₁, E1C19-0 bits =C₁
- EQ2: E2A19-0 bits =A₂, E2B19-0 bits =B₂, E2C19-0 bits =C₂
- EQ3: E3A19-0 bits =A₃, E3B19-0 bits =B₃, E3C19-0 bits =C₃
- EQ4: E4A19-0 bits =A₄, E4B19-0 bits =B₄, E4C19-0 bits =C₄
- EQ5: E5A19-0 bits =A₅, E5B19-0 bits =B₅, E5C19-0 bits =C₅
- (MSB=E1A19, E1B19, E1C19, E2A19, E2B19, E2C19, E3A19, E3B19, E3C19, E4A19, E4B19, E4C19, E5A19, E5B19, E5C19; LSB= E1A0, E1B0, E1C0, E2A0, E2B0, E2C0, E3A0, E3B0, E3C0, E4A0, E4B0, E4C0, E5A0, E5B0, E5C0)

$$A_n = K_n \times \frac{\tan(\pi f b_n / f_s)}{1 + \tan(\pi f b_n / f_s)}, \quad B_n = \cos(2\pi f_0 n / f_s) \times \frac{2}{1 + \tan(\pi f b_n / f_s)}, \quad C_n = -\frac{1 - \tan(\pi f b_n / f_s)}{1 + \tan(\pi f b_n / f_s)}$$

(n = 1, 2, 3, 4, 5)

Transfer function

$$H(z) = 1 + h_1(z) + h_2(z) + h_3(z) + h_4(z) + h_5(z)$$

$$h_n(z) = A_n \frac{1 - z^{-2}}{1 - B_n z^{-1} - C_n z^{-2}}$$

(n = 1, 2, 3, 4, 5)

The f_{bn} should be set within the range as follows.

$$f b_n / f_s \leq 0.25$$

The f_{0n} (center frequency) should be set within the range as follows.

$$3.125 \times 10^{-3} \leq f_0 n / f_s < 0.4969$$

When the f_{0n}/f_s is less than 3.125x10⁻³, the step width of the f_{0n} which can be set up becomes the biggest in the case of f_{bn}/f_s=0.25. (Table 31)

f _{0n} /f _s	f _{0n} (@f _s =48kHz)	A _n (dec) (K _n =-1)	B _n (dec)	C _n (dec)
8.542x10 ⁻⁴	41Hz	-65536	131070	0
1.083x10 ⁻³	52Hz	-65536	131069	0
1.229x10 ⁻³	59Hz	-65536	131068	0
⋮	⋮	⋮	⋮	⋮
3.125x10 ⁻³	150Hz	-65536	131047	0

Table 31. The Center Frequency in the low frequency band (when the coefficients of A_n, B_n and C_n is f_{bn}/f_s=0.25)

Note 25. Translation the filter coefficient calculated by the equations above from real number to binary code (2's complement)

$$X = (\text{Real number of filter coefficient calculated by the equations above}) \times 2^{17}$$

X should be rounded to integer, and then should be translated to binary code (2's complement).

MSB of each filter coefficient setting register is sign bit.

■ Limiter Operation

ALMT1 bit controls ON/OFF of the limiter operation of the DSP1 block. ALMT2 bit controls ON/OFF of the limiter operation of the DSP2 block. DSP1 block and DSP2 block are controlled completely independent by Limiter Mode Control, Timer Select and Reference Level control bits.

1. Limiter Movement

During a limiter operation, when either Lch or Rch exceeds the limiter detection level (Table 32), the VOL values (same value for Lch and Rch) are attenuated automatically by the amount defined by the limiter ATT step set by LMAT1-0 bits (Table 33).

When ZELMN bit = "0" (zero cross detection is enabled), LFSTN bit = "0" (fast limiter is enabled) and the output level is less than full-scale, the VOL values (Lch and Rch) are changed by a limiter operation at the individual zero crossing points of Lch and Rch or at the zero crossing timeout. ZTM1-0 bits set the zero crossing timeout period of both limiter and recovery operation (Table 34). When the output level exceeds full-scale, VOL values are immediately (Period: 1/fs) changed. When LFSTN bit = "1" (fast limiter is disabled), VOL values are changed at the individual zero crossing point of each channels or at the zero crossing timeout regardless of the output level.

When ZELMN bit = "1" (zero cross detection is disabled), VOL values are immediately (period: 1/fs) changed by a limiter operation. Attenuation step is fixed to 1 step regardless of the LMAT1-0 bits setting.

After completing the attenuate operation, unless ALMT1 bit or ALMT2 bit is changed to "0", the operation repeats when the input signal level exceeds limiter detection level.

LMTH1 bit	LMTH0 bit	Limier Detection Level	Recovery Waiting Counter Reset Level	
0	0	Limiter Output $\geq -2.5\text{dBFS}$	$-2.5\text{dBFS} > \text{Limiter Output} \geq -4.1\text{dBFS}$	(default)
0	1	Limiter Output $\geq -4.1\text{dBFS}$	$-4.1\text{dBFS} > \text{Limiter Output} \geq -6.0\text{dBFS}$	
1	0	Limiter Output $\geq -6.0\text{dBFS}$	$-6.0\text{dBFS} > \text{Limier Output} \geq -8.5\text{dBFS}$	
1	1	Limiter Output $\geq -8.5\text{dBFS}$	$-8.5\text{dBFS} > \text{Limier Output} \geq -12\text{dBFS}$	

Table 32. Limiter Detection Level / Recovery Counter Reset Level

LMAT1 bit	LMAT0 bit	Limiter ATT Step (0.375dB/step)				
		Limiter Output $\geq \text{LMTH}$	Limiter Output $\geq \text{FS}$	Limiter Output $\geq \text{FS} + 6\text{dB}$	Limiter Output $\geq \text{FS} + 12\text{dB}$	
0	0	1	1	1	1	(default)
0	1	2	2	2	2	
1	0	2	4	4	8	
1	1	1	2	4	8	

Table 33. Limiter ATT Step

ZTM1 bit	ZTM0 bit	Zero Crossing Timeout Period				
			8kHz	16kHz	44.1kHz	
0	0	128/fs	16ms	8ms	2.9ms	(default)
0	1	256/fs	32ms	16ms	5.8ms	
1	0	512/fs	64ms	32ms	11.6ms	
1	1	1024/fs	128ms	64ms	23.2ms	

Table 34. Zero Crossing Timeout Period

2. Limiter Recovery Operation

A limiter recovery operation waits for the WTM2-0 bits (Table 35) to be set after completing a limiter operation. If the input signal does not exceed “recovery waiting counter reset level” (Table 32) during the wait time, the limiter recovery operation is completed. The VOL values (Lch and Rch) are automatically incremented by RGAIN1-0 bits (Table 36) up to the set reference level (Table 37) with zero crossing detection which timeout period is set by ZTM1-0 bits (Table 34). Then the VOL's are set to the same value for both channels. This limiter recovery operation is executed at a period set by WTM2-0 bits. When zero cross is detected at both channels during the wait period set by WTM2-0 bits, a limiter recovery operation waits until WTM2-0 period and the next recovery operation is completed. If ZTM1-0 is longer than WTM2-0 and no zero crossing occurs, a limiter recovery operation is made at a period set by ZTM1-0 bits.

For example, when the current VOL value is 30H and RGAIN1-0 bits are set to “01” (2 steps), VOL is changed to 32H by the limiter operation and then the input signal level is gained by 0.75dB (=0.375dB x 2). When the VOL value exceeds the reference level (REF7-0 bits), the VOL values are not increased.

When

“Limiter recovery waiting counter reset level (LMTH1-0) \leq Output Signal < Limiter detection level (LMTH1-0)” during a limiter recovery operation, the waiting timer of limiter recovery operation is reset.

When

“Limiter recovery waiting counter reset level (LMTH1-0) > Output Signal”, the waiting timer of limiter recovery operation starts.

The limiter operation corresponds to the impulse noise. When the impulse noise is input, limiter recovery operation is faster than a normal recovery operation (Fast Recovery Operation). When large noise is input to microphone instantaneously, quality of small signal level in the large noise can be improved by this fast recovery operation. The speed of fast recovery operation is set by RFST1-0 bits (Table 38).

WTM2 bit	WTM1 bit	WTM0 bit	Recovery Operation Waiting Period				
			8kHz	16kHz	44.1kHz		
0	0	0	128/fs	16ms	8ms	2.9ms	(default)
0	0	1	256/fs	32ms	16ms	5.8ms	
0	1	0	512/fs	64ms	32ms	11.6ms	
0	1	1	1024/fs	128ms	64ms	23.2ms	
1	0	0	2048/fs	256ms	128ms	46.4ms	
1	0	1	4096/fs	512ms	256ms	92.9ms	
1	1	0	8192/fs	1024ms	512ms	185.8ms	
1	1	1	16384/fs	2048ms	1024ms	371.5ms	

Table 35. Recovery Operation Waiting Period

RGAIN1 bit	RGAIN0 bit	GAIN STEP		
0	0	1 step	0.375dB	(default)
0	1	2 step	0.750dB	
1	0	3 step	1.125dB	
1	1	4 step	1.500dB	

Table 36. Recovery GAIN Step

REF7-0 bits	GAIN(dB)	Step (dB)
F1H	0	0.375
F0H	-0.375	
EFH	-0.75	
:	:	
A0H	-30.375	
9FH	-30.75	
9EH	-31.125	
:	:	
50H	-60.375	
4FH	-60.75	
4EH	-61.125	
:	:	
02H	-89.625	
01H	-90.0	
00H	MUTE	

(default)

Table 37. Reference Level at Recovery Operation

RFST1 bit	RFST0 bit	Recovery Speed
0	0	4 times
0	1	8 times
1	0	16times
1	1	N/A

(default)

Table 38. Fast Recovery Speed Setting (N/A: not available)

3. Example of the Limiter Operation Setup

An example of the limiter setting is shown in [Table 39](#).

Register Name	Comment	fs=8kHz		fs=44.1kHz	
		Data	Operation	Data	Operation
LMTH1-0	Limiter detection Level	01	-4.1dBFS	01	-4.1dBFS
ZELMN	Limiter zero crossing detection	0	Enable	0	Enable
ZTM1-0	Zero crossing timeout period	01	32ms	11	23.2ms
WTM2-0	Recovery waiting period *WTM2-0 bits should be the same or longer data as ZTM1-0 bits.	001	32ms	011	23.2ms
REF7-0	Reference level at recovery operation	F1H	0dB	F1H	0dB
LMAT1-0	Limiter ATT step	00	1 step	00	1 step
RGAIN1-0	Recovery GAIN step	00	1 step	00	1 step
RFST1-0	Fast Recovery Speed	00	4 times	00	4 times

Table 39. Example of the Limiter Operation Setting

■ Line Outputs

Line outputs of the AK4753 have internal resistors in series. The resistor value is 200Ω (typ). By just connecting small capacitors between VSS1 and each the LOUT1/2 or ROUT1/2 pin, high frequency noise will be significantly reduced.

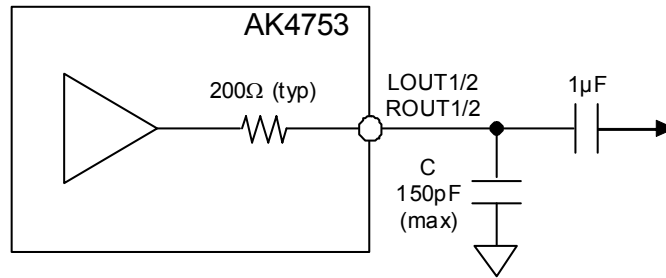

Figure 57. External Circuit for Stereo Line Outputs (In case of using high frequency noise reduction circuit.)

<Line Outputs Control Sequence>

The AK4753 has a mute control output pin (MUTEN pin) for external speaker amplifier. In order to prevent a pop noise through the AK4753, the MTUEN pin is connected to a mute pin or a standby pin of the external speaker amplifier.

In the PLL mode, when the PLL is unlocked or the line outputs are disabled, the MUTEN outputs “L”. When the PLL is locked and the line outputs are enabled, the MUTEN outputs “H”.

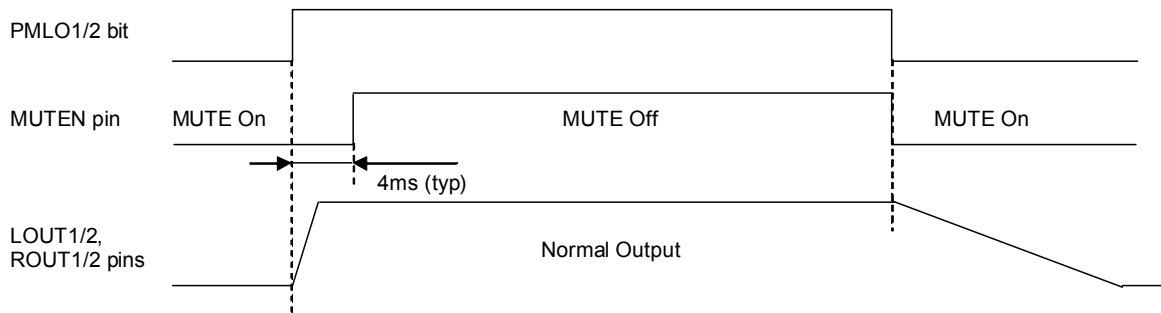

Figure 58. Line Outputs Control Sequence

■ SAR 8-bit ADC

The AK4753 incorporates a 8-bit successive approximation resistor A/D converter for DC measurement. By connecting potentiometers, the gain of DATT can be controlled by SAIN1 and the gain of EQ1 can be controlled by SAIN2.

The A/D converter output for the SAIN1 pin is a straight binary format as shown in [Table 40](#).

Input Voltage	Output Code	Attenuation Level
(AVDD-1.0LSB) ~ AVDD	00H	0dB
(AVDD-2.0LSB) ~ (AVDD-1.0LSB)	01H	-0.5dB
:	:	:
1.0LSB ~ 2.0LSB	FEH	-127dB
0 ~ 1.0LSB	FFH	MUTE ($-\infty$)

Table 40. Output Code for the SAIN1 Pin

The A/D converter output for the SAIN2 pin is a straight binary format as shown in [Table 41](#).

Input Voltage	Output Code
(AVDD-1.0LSB) ~ AVDD	00H
(AVDD-2.0LSB) ~ (AVDD-1.0LSB)	01H
:	:
1.0LSB ~ 2.0LSB	FEH
0 ~ 1.0LSB	FFH

Table 41. Output Code for the SAIN2 pin

Output Code	Gain@EQ1	K_1 @EQ1
00H ~ 04H	+12.0dB	2.981
05H ~ 09H		
0AH ~ 0EH	+11.5dB	2.758
0FH ~ 13H	+11.0dB	2.548
14H ~ 18H	+10.5dB	2.350
:	:	:
7DH ~ 81H	0dB	0
:	:	:
E6H ~ EAH	-10.5dB	-0.701
EBH ~ EFH	-11.0dB	-0.718
F0H ~ F4H	-11.5dB	-0.734
F5H ~ F9H	-12.0dB	-0.749
FAH ~ FFH		

Table 42. Gain Setting of EQ1

SA2SEL bit	K_1
0	DSP1
1	DSP2

(default)

Table 43. Source for the SAIN2 pin

SA2 bit	SAIN2 pin
0	Disable
1	Enable

(default)

Table 44. Configuration for the SAIN2 pin

CTM1 bit	CTM0 bit	Cycle Time		
		fs=8kHz	fs=44.1kHz	
0	0	4/fs	0.5ms	0.09ms (default)
0	1	8/fs	1.0ms	0.18ms
1	0	16/fs	2.0ms	0.36ms
1	1	32/fs	4.0ms	0.73ms

Table 45. Cycle Time Setting

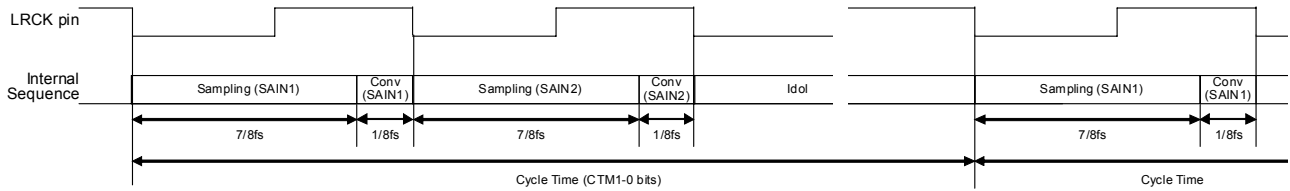

Figure 59. SAR Control Sequence (SA2 bit = "1")

■ EEP-ROM Interface (EXTEE pin = "H")

The AK4753 has EEP-ROM I/F to read out the coefficient values for the DSP blocks and the setting data from an external EEP-ROM to the internal register. DSP function is easily realized in the system using EEP-ROM without extra microprocessor. The external EEP-ROM must be connected to the EESCL and EESDA pin of the AK4753. The AK4753 can operate as a master device on the I²C bus network. A connection example is shown in Figure 60.

1. EEP-ROM Data Read Operation

Before start downloading, data must be written to the EEP-ROM.

The AK4753 should be powered up when the PDN pin = "L". After all power supplies are ON and the EXTEE pin = "H", the AK4753 starts downloading the data from the EEP-ROM when the PDN pin (Figure 61) is set to "H". The internal OSC of the AK4753 is powered-up by this start setting, and the register data are readout from the EEP-ROM. The AK4753 I²C master device assumes that there is not another I²C master device on the same bus during downloading data. Therefore, the I²C I/F of the microprocessor should be set to Hi-Z state or powered-down. This data download from EEP-ROM takes 6ms (max). In the EEP-ROM data read operation, error detection results of an EEP-ROM data read can be monitored on the STO pin. The STO pin outputs "L" when no errors are found. When a read error is detected, the internal logic circuit repeats data read from EEPROM for nine times (max). If errors are detected for nine times, the read operation is stopped and the STO pin outputs "H".

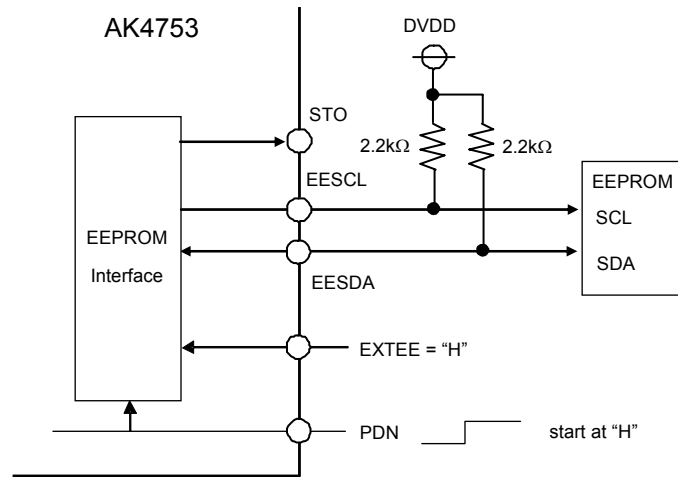

Figure 60. Connection Example of the AK4753 and EEP-ROM (I²C)

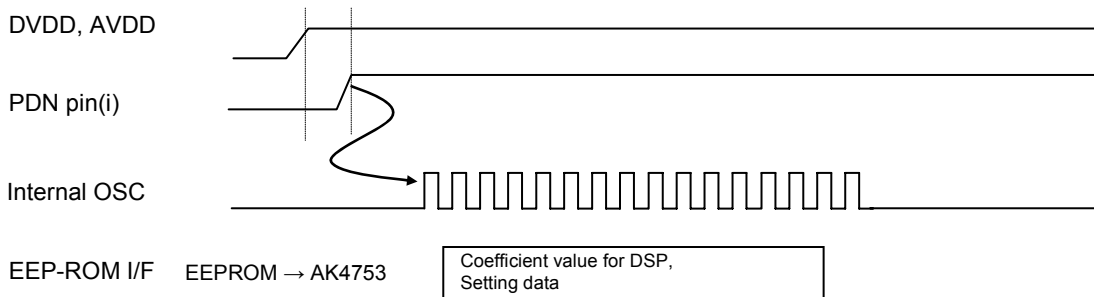

Figure 61. EEP-ROM Download Sequence

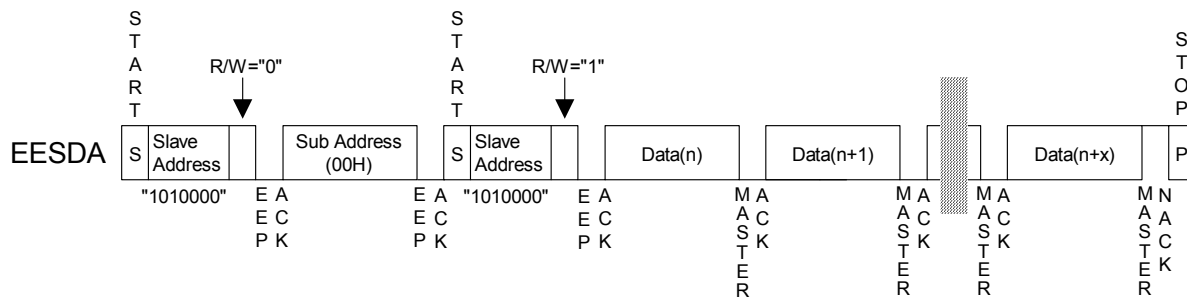

Figure 62. EEP-ROM Sequential Read Sequence

1	0	1	0	0	0	0	R/W
---	---	---	---	---	---	---	-----

Figure 63. Slave Address Byte for EEP-ROM read operation

0	0	0	0	0	0	0	0
---	---	---	---	---	---	---	---

Figure 64. Sub Address Byte for EEP-ROM read operation

D7	D6	D5	D4	D3	D2	D1	D0
----	----	----	----	----	----	----	----

Figure 65. Data Byte for EEP-ROM read operation

2. EEP-ROM Memory Map

The AK4753 only supports 1k bytes or larger I²C type EEP-ROM. The EEP-ROM is used for storing the control registers. The contents of EEP-ROM memory map are same as the register map.

(1) Fundamental function block

Addr	Contents
00H	Signal Path
01H	SAR Control
02H	Mode Setting 1
03H	Mode Setting 2
04H	Power Management
05H	Lch DATT
06H	Rch DATT
07H	Gain Setting
08H	DSP1 Limiter Mode Control
09H	DSP1 Timer Select
0AH	DSP1 Reference Level
0BH	DSP2 Limiter Mode Control
0CH	DSP2 Timer Select
0DH	DSP2 Reference Level

(2) DSP1 function block

Addr	Contents
0EH	DSP1 HPF/LPF Setting
0FH~17H	DSP1 Filter Coefficient
18H	DSP1 EQ Select
19H~21H	DSP1 EQ1 Coefficient
22H~2AH	DSP1 EQ2 Coefficient
2BH~33H	DSP1 EQ3 Coefficient
34H~3CH	DSP1 EQ4 Coefficient
3DH~45H	DSP1 EQ5 Coefficient

(3) DSP2 function block

Addr	Contents
46H	DSP2 HPF/LPF Setting
47H~4FH	DSP2 Filter Coefficient
50H	DSP2 EQ Select
51H~59H	DSP2 EQ1 Coefficient
5AH~62H	DSP2 EQ2 Coefficient
63H~6BH	DSP2 EQ3 Coefficient
6CH~74H	DSP2 EQ4 Coefficient
75H~7DH	DSP2 EQ5 Coefficient
7FH	Reserved

■ Serial Control Interface (I2C-bus Control: EXTEE pin = “L”)

The AK4753 supports the fast-mode I²C-bus (max: 400kHz). Pull-up resistors at the SDA and SCL pins must be connected to (DVDD+0.3)V or less voltage.

1. WRITE Operations

Figure 66 shows the data transfer sequence for the I²C-bus mode. All commands are preceded by a START condition. A HIGH to LOW transition on the SDA line while SCL is HIGH indicates a START condition (Figure 72). After the START condition, a slave address is sent. This address is 7 bits long followed by the eighth bit that is a data direction bit (R/W). The most significant seven bits of the slave address are fixed as “0010010” (Figure 67). If the slave address matches that of the AK4753, the AK4753 generates an acknowledge and the operation is executed. The master must generate the acknowledge-related clock pulse and release the SDA line (HIGH) during the acknowledge clock pulse (Figure 73). A R/W bit value of “1” indicates that the read operation is to be executed, and “0” indicates that the write operation is to be executed.

The second byte consists of the control register address of the AK4753. The format is MSB first, and those most significant 1bit is fixed to zero (Figure 68). The data after the second byte contains control data. The format is MSB first, 8bits (Figure 69). The AK4753 generates an acknowledge after each byte is received. Data transfer is always terminated by a STOP condition generated by the master. A LOW to HIGH transition on the SDA line while SCL is HIGH defines a STOP condition (Figure 72).

The AK4753 can perform more than one byte write operation per sequence. After receipt of the third byte the AK4753 generates an acknowledge and awaits the next data. The master can transmit more than one byte instead of terminating the write cycle after the first data byte is transferred. After receiving each data packet the internal address counter is incremented by one, and the next data is automatically taken into the next address. If the address exceeds 7DH prior to generating a stop condition, the address counter will “roll over” to 00H and the previous data will be overwritten.

The data on the SDA line must remain stable during the HIGH period of the clock. HIGH or LOW state of the data line can only be changed when the clock signal on the SCL line is LOW (Figure 74) except for the START and STOP conditions.

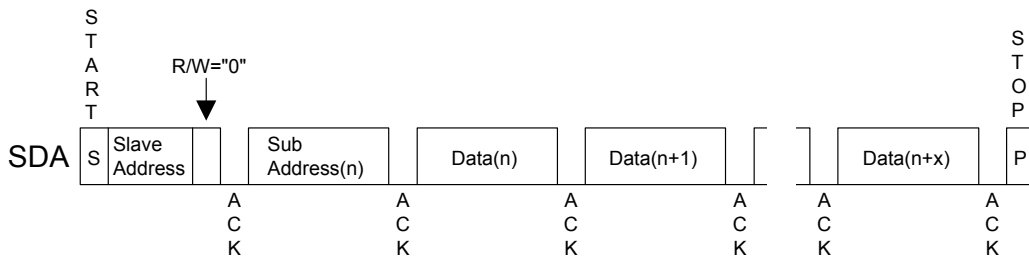

Figure 66. Data Transfer Sequence at I²C Bus Mode

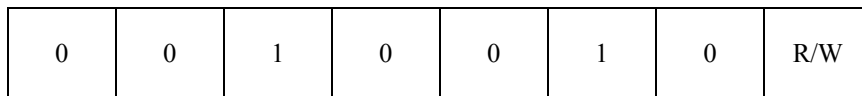

Figure 67. The First Byte

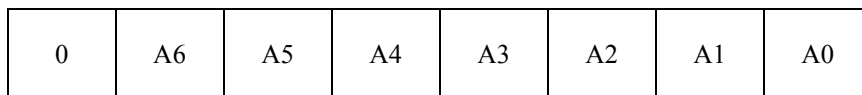

Figure 68. The Second Byte

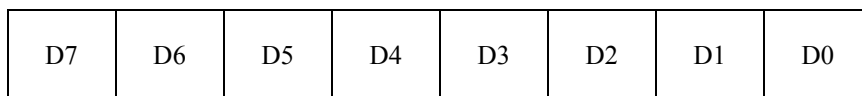

Figure 69. The Third Byte

2. READ Operations

Set the R/W bit = "1" for the READ operation of the AK4753. After transmission of data, the master can read the next address's data by generating an acknowledge instead of terminating the write cycle after the receipt of the first data word. After receiving each data packet the internal address counter is incremented by one, and the next data is automatically taken into the next address. If the address exceeds 7DH prior to generating stop condition, the address counter will "roll over" to 00H and the data of 00H will be read out.

The AK4753 supports two basic read operations: CURRENT ADDRESS READ and RANDOM ADDRESS READ.

2-1. CURRENT ADDRESS READ

The AK4753 has an internal address counter that maintains the address of the last accessed word incremented by one. Therefore, if the last access (either a read or write) were to address "n", the next CURRENT READ operation would access data from the address "n+1". After receipt of the slave address with R/W bit "1", the AK4753 generates an acknowledge, transmits 1-byte of data to the address set by the internal address counter and increments the internal address counter by 1. If the master does not generate an acknowledge but generates a stop condition instead, the AK4753 ceases the transmission.

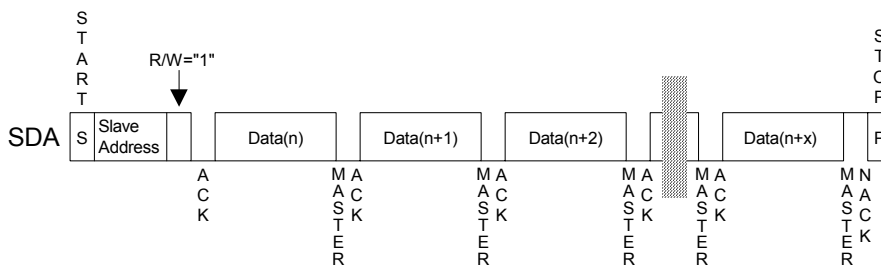

Figure 70. Current Address Read

2-2. RANDOM ADDRESS READ

The random read operation allows the master to access any memory location at random. Prior to issuing the slave address with the R/W bit "1", the master must first perform a "dummy" write operation. The master issues a start request, a slave address (R/W bit = "0") and then the register address to read. After the register address is acknowledged, the master immediately reissues the start request and the slave address with the R/W bit "1". The AK4753 then generates an acknowledge, 1 byte of data and increments the internal address counter by 1. If the master does not generate an acknowledge but generates a stop condition instead, the AK4753 ceases the transmission.

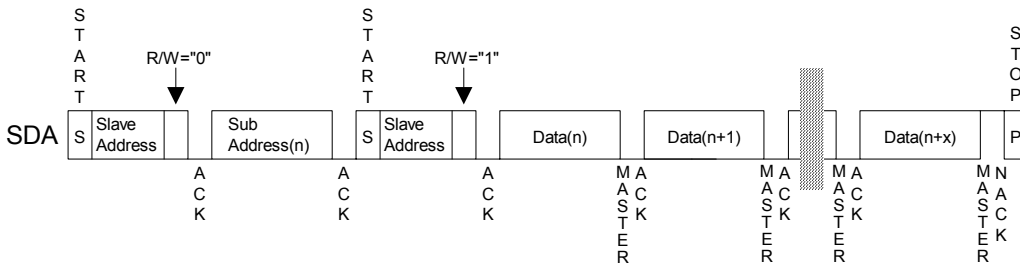

Figure 71. Random Address Read

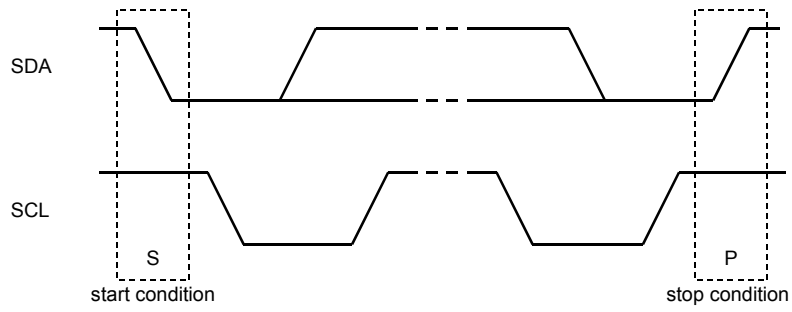

Figure 72. Start Condition and Stop Condition

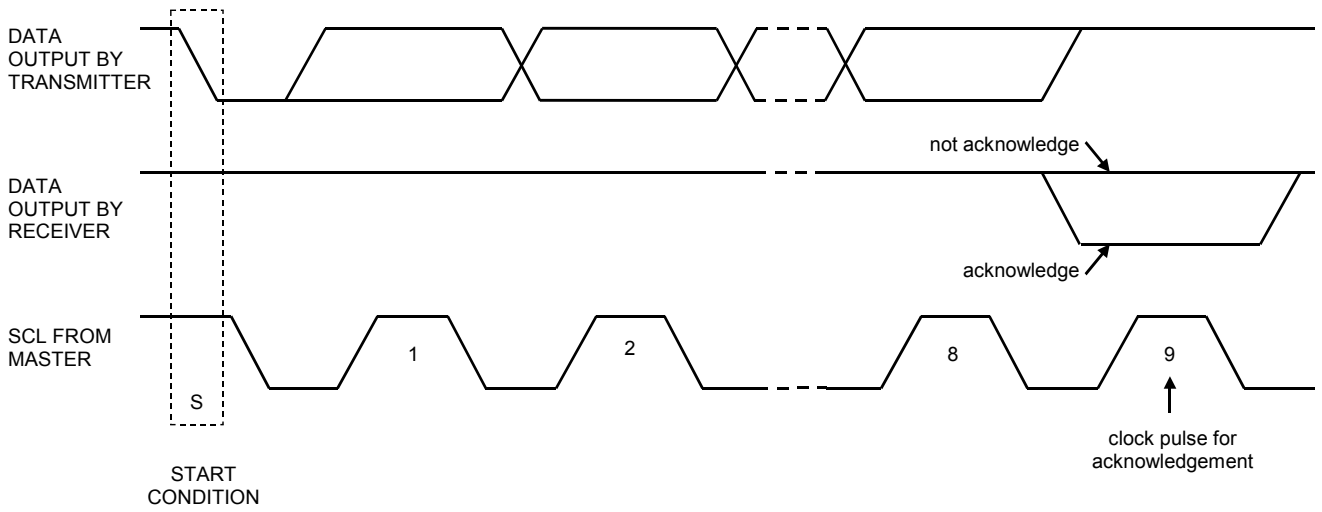

Figure 73. Acknowledge (I²C Bus)

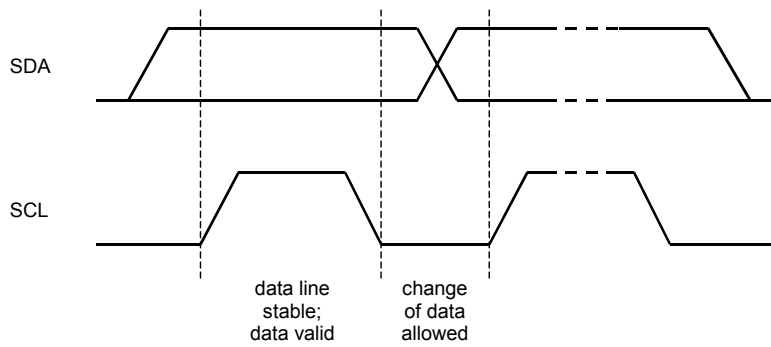

Figure 74. Bit Transfer (I²C Bus)

■ Register Map

In this section, the fundamental functions (Address: 00H to 0DH), the DSP1 functions (Address: 0EH to 45H), and the DSP2 functions (Address: 46H to 7DH) are shown in three subsections.

Note 26. PDN pin = “L” resets the registers to their default values.

Note 27. The bits defined as 0 must contain a “0” value.

1. Register Map of Fundamental function

Addr	Register Name	D7	D6	D5	D4	D3	D2	D1	D0
00H	SAR Control	CTM1	CTM0	SA2SEL	SA2	PMSAR	0	0	0
01H	Signal Path	ALMT1	ALMT2	SPC1	SPC0	0	SEL1	0	SEL0
02H	Mode Setting 1	FS3	FS2	FS1	FS0	PLL3	PLL2	PLL1	PLL0
03H	Mode Setting 2	BCKO	M/S	BCKP	MSBS	0	DIF2	DIF1	DIF0
04H	Power Management	PMPLL	0	PMLO2	PMLO1	PMDIG	PWXTL	0	PMADC
05H	Lch DATT	L7	L6	L5	L4	L3	L2	L1	L0
06H	Rch DATT	R7	R6	R5	R4	R3	R2	R1	R0
07H	Gain Setting	1PSTG1	1PSTG0	1PREG1	1PREG0	2PSTG1	2PSTG0	2PREG1	2PREG0
08H	DSP1 Limiter Mode Control	1LFSTN	1ZELMN	1RGAIN1	1RGAIN0	1LMAT1	1LMAT0	1LMTH1	1LMTH0
09H	DSP1 Timer Select	1RFST1	1RFST0	1WTM2	1WTM1	1WTM0	1ZTM1	1ZTM0	DVTM
0AH	DSP1 Reference Level	1REF7	1REF6	1REF5	1REF4	1REF3	1REF2	1REF1	1REF0
0BH	DSP2 Limiter Mode Control	2LFSTN	2ZELMN	2RGAIN1	2RGAIN0	2LMAT1	2LMAT0	2LMTH1	2LMTH0
0CH	DSP2 Timer Select	2RFST1	2RFST0	2WTM2	2WTM1	2WTM0	2ZTM1	2ZTM0	0
0DH	DSP2 Reference Level	2REF7	2REF6	2REF5	2REF4	2REF3	2REF2	2REF1	2REF0

2. Register Map of DSP1 function

Addr	Register Name	D7	D6	D5	D4	D3	D2	D1	D0
0EH	HPF/LPF Setting	0	0	0	0	0	0	1FILSEL	1FILEN
0FH	DSP1 Filter A Coefficient 1	1FA7	1FA6	1FA5	1FA4	1FA3	1FA2	1FA1	1FA0
10H	DSP1 Filter A Coefficient 2	1FA15	1FA14	1FA13	1FA12	1FA11	1FA10	1FA9	1FA8
11H	DSP1 Filter A Coefficient 3	0	0	0	0	1FA19	1FA18	1FA17	1FA16
12H	DSP1 Filter B Coefficient 1	1FB7	1FB6	1FB5	1FB4	1FB3	1FB2	1FB1	1FB0
13H	DSP1 Filter B Coefficient 2	1FB15	1FB14	1FB13	1FB12	1FB11	1FB10	1FB9	1FB8
14H	DSP1 Filter B Coefficient 3	0	0	0	0	1FB19	1FB18	1FB17	1FB16
15H	DSP1 Filter C Coefficient 1	1FC7	1FC6	1FC5	1FC4	1FC3	1FC2	1FC1	1FC0
16H	DSP1 Filter C Coefficient 2	1FC15	1FC14	1FC13	1FC12	1FC11	1FC10	1FC9	1FC8
17H	DSP1 Filter C Coefficient 3	0	0	0	0	1FC19	1FC18	1FC17	1FC16

Addr	Register Name	D7	D6	D5	D4	D3	D2	D1	D0
18H	DSP1 EQ Select	0	0	0	1EQ5	1EQ4	1EQ3	1EQ2	1EQ1
19H	DSP1 EQ1 A Coefficient 1	1E1A7	1E1A6	1E1A5	1E1A4	1E1A3	1E1A2	1E1A1	1E1A0
1AH	DSP1 EQ1 A Coefficient 2	1E1A15	1E1A14	1E1A13	1E1A12	1E1A11	1E1A10	1E1A9	1E1A8
1BH	DSP1 EQ1 A Coefficient 3	0	0	0	0	1E1A19	1E1A18	1E1A17	1E1A16
1CH	DSP1 EQ1 B Coefficient 1	1E1B7	1E1B6	1E1B5	1E1B4	1E1B3	1E1B2	1E1B1	1E1B0
1DH	DSP1 EQ1 B Coefficient 2	1E1B15	1E1B14	1E1B13	1E1B12	1E1B11	1E1B10	1E1B9	1E1B8
1EH	DSP1 EQ1 B Coefficient 3	0	0	0	0	1E1B19	1E1B18	1E1B17	1E1B16
1FH	DSP1 EQ1 C Coefficient 1	1E1C7	1E1C6	1E1C5	1E1C4	1E1C3	1E1C2	1E1C1	1E1C0
20H	DSP1 EQ1 C Coefficient 2	1E1C15	1E1C14	1E1C13	1E1C12	1E1C11	1E1C10	1E1C9	1E1C8
21H	DSP1 EQ1 C Coefficient 3	0	0	0	0	1E1C19	1E1C18	1E1C17	1E1C16
22H	DSP1 EQ2 A Coefficient 1	1E2A7	1E2A6	1E2A5	1E2A4	1E2A3	1E2A2	1E2A1	1E2A0
23H	DSP1 EQ2 A Coefficient 2	1E2A15	1E2A14	1E2A13	1E2A12	1E2A11	1E2A10	1E2A9	1E2A8
24H	DSP1 EQ2 A Coefficient 3	0	0	0	0	1E2A19	1E2A18	1E2A17	1E2A16
25H	DSP1 EQ2 B Coefficient 1	1E2B7	1E2B6	1E2B5	1E2B4	1E2B3	1E2B2	1E2B1	1E2B0
26H	DSP1 EQ2 B Coefficient 2	1E2B15	1E2B14	1E2B13	1E2B12	1E2B11	1E2B10	1E2B9	1E2B8
27H	DSP1 EQ2 B Coefficient 3	0	0	0	0	1E2B19	1E2B18	1E2B17	1E2B16
28H	DSP1 EQ2 C Coefficient 1	1E2C7	1E2C6	1E2C5	1E2C4	1E2C3	1E2C2	1E2C1	1E2C0
29H	DSP1 EQ2 C Coefficient 2	1E2C15	1E2C14	1E2C13	1E2C12	1E2C11	1E2C10	1E2C9	1E2C8
2AH	DSP1 EQ2 C Coefficient 3	0	0	0	0	1E2C19	1E2C18	1E2C17	1E2C16
2BH	DSP1 EQ3 A Coefficient 1	1E3A7	1E3A6	1E3A5	1E3A4	1E3A3	1E3A2	1E3A1	1E3A0
2CH	DSP1 EQ3 A Coefficient 2	1E3A15	1E3A14	1E3A13	1E3A12	1E3A11	1E3A10	1E3A9	1E3A8
2DH	DSP1 EQ3 A Coefficient 3	0	0	0	0	1E3A19	1E3A18	1E3A17	1E3A16
2EH	DSP1 EQ3 B Coefficient 1	1E3B7	1E3B6	1E3B5	1E3B4	1E3B3	1E3B2	1E3B1	1E3B0
2FH	DSP1 EQ3 B Coefficient 2	1E3B15	1E3B14	1E3B13	1E3B12	1E3B11	1E3B10	1E3B9	1E3B8
30H	DSP1 EQ3 B Coefficient 3	0	0	0	0	1E3B19	1E3B18	1E3B17	1E3B16
31H	DSP1 EQ3 C Coefficient 1	1E3C7	1E3C6	1E3C5	1E3C4	1E3C3	1E3C2	1E3C1	1E3C0
32H	DSP1 EQ3 C Coefficient 2	1E3C15	1E3C14	1E3C13	1E3C12	1E3C11	1E3C10	1E3C9	1E3C8
33H	DSP1 EQ3 C Coefficient 3	0	0	0	0	1E3C19	1E3C18	1E3C17	1E3C16

Addr	Register Name	D7	D6	D5	D4	D3	D2	D1	D0
34H	DSP1 EQ4 A Coefficient 1	1E4A7	1E4A6	1E4A5	1E4A4	1E4A3	1E4A2	1E4A1	1E4A0
35H	DSP1 EQ4 A Coefficient 2	1E4A15	1E4A14	1E4A13	1E4A12	1E4A11	1E4A10	1E4A9	1E4A8
36H	DSP1 EQ4 A Coefficient 3	0	0	0	0	1E4A19	1E4A18	1E4A17	1E4A16
37H	DSP1 EQ4 B Coefficient 1	1E4B7	1E4B6	1E4B5	1E4B4	1E4B3	1E4B2	1E4B1	1E4B0
38H	DSP1 EQ4 B Coefficient 2	1E4B15	1E4B14	1E4B13	1E4B12	1E4B11	1E4B10	1E4B9	1E4B8
39H	DSP1 EQ4 B Coefficient 3	0	0	0	0	1E4B19	1E4B18	1E4B17	1E4B16
3AH	DSP1 EQ4 C Coefficient 1	1E4C7	1E4C6	1E4C5	1E4C4	1E4C3	1E4C2	1E4C1	1E4C0
3BH	DSP1 EQ4 C Coefficient 2	1E4C15	1E4C14	1E4C13	1E4C12	1E4C11	1E4C10	1E4C9	1E4C8
3CH	DSP1 EQ4 C Coefficient 3	0	0	0	0	1E4C19	1E4C18	1E4C17	1E4C16
3DH	DSP1 EQ5 A Coefficient 1	1E5A7	1E5A6	1E5A5	1E5A4	1E5A3	1E5A2	1E5A1	1E5A0
3EH	DSP1 EQ5 A Coefficient 2	1E5A15	1E5A14	1E5A13	1E5A12	1E5A11	1E5A10	1E5A9	1E5A8
3FH	DSP1 EQ5 A Coefficient 3	0	0	0	0	1E5A19	1E5A18	1E5A17	1E5A16
40H	DSP1 EQ5 B Coefficient 1	1E5B7	1E5B6	1E5B5	1E5B4	1E5B3	1E5B2	1E5B1	1E5B0
41H	DSP1 EQ5 B Coefficient 2	1E5B15	1E5B14	1E5B13	1E5B12	1E5B11	1E5B10	1E5B9	1E5B8
42H	DSP1 EQ5 B Coefficient 3	0	0	0	0	1E5B19	1E5B18	1E5B17	1E5B16
43H	DSP1 EQ5 C Coefficient 1	1E5C7	1E5C6	1E5C5	1E5C4	1E5C3	1E5C2	1E5C1	1E5C0
44H	DSP1 EQ5 C Coefficient 2	1E5C15	1E5C14	1E5C13	1E5C12	1E5C11	1E5C10	1E5C9	1E5C8
45H	DSP1 EQ5 C Coefficient 3	0	0	0	0	1E5C19	1E5C18	1E5C17	1E5C16

3. Register Map of DSP2 function

Addr	Register Name	D7	D6	D5	D4	D3	D2	D1	D0
46H	HPF/LPF Setting	0	0	0	0	0	0	2FILSEL	2FILEN
47H	DSP2 Filter A Coefficient 1	2FA7	2FA6	2FA5	2FA4	2FA3	2FA2	2FA1	2FA0
48H	DSP2 Filter A Coefficient 2	2FA15	2FA14	2FA13	2FA12	2FA11	2FA10	2FA9	2FA8
49H	DSP2 Filter A Coefficient 3	0	0	0	0	2FA19	2FA18	2FA17	2FA16
4AH	DSP2 Filter B Coefficient 1	2FB7	2FB6	2FB5	2FB4	2FB3	2FB2	2FB1	2FB0
4BH	DSP2 Filter B Coefficient 2	2FB15	2FB14	2FB13	2FB12	2FB11	2FB10	2FB9	2FB8
4CH	DSP2 Filter B Coefficient 3	0	0	0	0	2FB19	2FB18	2FB17	2FB16
4DH	DSP2 Filter C Coefficient 1	2FC7	2FC6	2FC5	2FC4	2FC3	2FC2	2FC1	2FC0

Addr	Register Name	D7	D6	D5	D4	D3	D2	D1	D0
4EH	DSP2 Filter C Coefficient 2	2FC15	2FC14	2FC13	2FC12	2FC11	2FC10	2FC9	2FC8
4FH	DSP2 Filter C Coefficient 3	0	0	0	0	2FC19	2FC18	2FC17	2FC16
50H	DSP2 EQ Select	0	0	0	2EQ5	2EQ4	2EQ3	2EQ2	2EQ1
51H	DSP2 EQ1 A Coefficient 1	2E1A7	2E1A6	2E1A5	2E1A4	2E1A3	2E1A2	2E1A1	2E1A0
52H	DSP2 EQ1 A Coefficient 2	2E1A15	2E1A14	2E1A13	2E1A12	2E1A11	2E1A10	2E1A9	2E1A8
53H	DSP2 EQ1 A Coefficient 3	0	0	0	0	2E1A19	2E1A18	2E1A17	2E1A16
54H	DSP2 EQ1 B Coefficient 1	2E1B7	2E1B6	2E1B5	2E1B4	2E1B3	2E1B2	2E1B1	2E1B0
55H	DSP2 EQ1 B Coefficient 2	2E1B15	2E1B14	2E1B13	2E1B12	2E1B11	2E1B10	2E1B9	2E1B8
56H	DSP2 EQ1 B Coefficient 3	0	0	0	0	2E1B19	2E1B18	2E1B17	2E1B16
57H	DSP2 EQ1 C Coefficient 1	2E1C7	2E1C6	2E1C5	2E1C4	2E1C3	2E1C2	2E1C1	2E1C0
58H	DSP2 EQ1 C Coefficient 2	2E1C15	2E1C14	2E1C13	2E1C12	2E1C11	2E1C10	2E1C9	2E1C8
59H	DSP2 EQ1 C Coefficient 3	0	0	0	0	2E1C19	2E1C18	2E1C17	2E1C16
5AH	DSP2 EQ2 A Coefficient 1	2E2A7	2E2A6	2E2A5	2E2A4	2E2A3	2E2A2	2E2A1	2E2A0
5BH	DSP2 EQ2 A Coefficient 2	2E2A15	2E2A14	2E2A13	2E2A12	2E2A11	2E2A10	2E2A9	2E2A8
5CH	DSP2 EQ2 A Coefficient 3	0	0	0	0	2E2A19	2E2A18	2E2A17	2E2A16
5DH	DSP2 EQ2 B Coefficient 1	2E2B7	2E2B6	2E2B5	2E2B4	2E2B3	2E2B2	2E2B1	2E2B0
5EH	DSP2 EQ2 B Coefficient 2	2E2B15	2E2B14	2E2B13	2E2B12	2E2B11	2E2B10	2E2B9	2E2B8
5FH	DSP2 EQ2 B Coefficient 3	0	0	0	0	2E2B19	2E2B18	2E2B17	2E2B16
60H	DSP2 EQ2 C Coefficient 1	2E2C7	2E2C6	2E2C5	2E2C4	2E2C3	2E2C2	2E2C1	2E2C0
61H	DSP2 EQ2 C Coefficient 2	2E2C15	2E2C14	2E2C13	2E2C12	2E2C11	2E2C10	2E2C9	2E2C8
62H	DSP2 EQ2 C Coefficient 3	0	0	0	0	2E2C19	2E2C18	2E2C17	2E2C16

Addr	Register Name	D7	D6	D5	D4	D3	D2	D1	D0
63H	DSP2 EQ3 A Coefficient 1	2E3A7	2E3A6	2E3A5	2E3A4	2E3A3	2E3A2	2E3A1	2E3A0
64H	DSP2 EQ3 A Coefficient 2	2E3A15	2E3A14	2E3A13	2E3A12	2E3A11	2E3A10	2E3A9	2E3A8
65H	DSP2 EQ3 A Coefficient 3	0	0	0	0	2E3A19	2E3A18	2E3A17	2E3A16
66H	DSP2 EQ3 B Coefficient 1	2E3B7	2E3B6	2E3B5	2E3B4	2E3B3	2E3B2	2E3B1	2E3B0
67H	DSP2 EQ3 B Coefficient 2	2E3B15	2E3B14	2E3B13	2E3B12	2E3B11	2E3B10	2E3B9	2E3B8
68H	DSP2 EQ3 B Coefficient 3	0	0	0	0	2E3B19	2E3B18	2E3B17	2E3B16
69H	DSP2 EQ3 C Coefficient 1	2E3C7	2E3C6	2E3C5	2E3C4	2E3C3	2E3C2	2E3C1	2E3C0
6AH	DSP2 EQ3 C Coefficient 2	2E3C15	2E3C14	2E3C13	2E3C12	2E3C11	2E3C10	2E3C9	2E3C8
6BH	DSP2 EQ3 C Coefficient 3	0	0	0	0	2E3C19	2E3C18	2E3C17	2E3C16
6CH	DSP2 EQ4 A Coefficient 1	2E4A7	2E4A6	2E4A5	2E4A4	2E4A3	2E4A2	2E4A1	2E4A0
6DH	DSP2 EQ4 A Coefficient 2	2E4A15	2E4A14	2E4A13	2E4A12	2E4A11	2E4A10	2E4A9	2E4A8
6EH	DSP2 EQ4 A Coefficient 3	0	0	0	0	2E4A19	2E4A18	2E4A17	2E4A16
6FH	DSP2 EQ4 B Coefficient 1	2E4B7	2E4B6	2E4B5	2E4B4	2E4B3	2E4B2	2E4B1	2E4B0
70H	DSP2 EQ4 B Coefficient 2	2E4B15	2E4B14	2E4B13	2E4B12	2E4B11	2E4B10	2E4B9	2E4B8
71H	DSP2 EQ4 B Coefficient 3	0	0	0	0	2E4B19	2E4B18	2E4B17	2E4B16
72H	DSP2 EQ4 C Coefficient 1	2E4C7	2E4C6	2E4C5	2E4C4	2E4C3	2E4C2	2E4C1	2E4C0
73H	DSP2 EQ4 C Coefficient 2	2E4C15	2E4C14	2E4C13	2E4C12	2E4C11	2E4C10	2E4C9	2E4C8
74H	DSP2 EQ4 C Coefficient 3	0	0	0	0	2E4C19	2E4C18	2E4C17	2E4C16
75H	DSP2 EQ5 A Coefficient 1	2E5A7	2E5A6	2E5A5	2E5A4	2E5A3	2E5A2	2E5A1	2E5A0
76H	DSP2 EQ5 A Coefficient 2	2E5A15	2E5A14	2E5A13	2E5A12	2E5A11	2E5A10	2E5A9	2E5A8
77H	DSP2 EQ5 A Coefficient 3	0	0	0	0	2E5A19	2E5A18	2E5A17	2E5A16
78H	DSP2 EQ5 B Coefficient 1	2E5B7	2E5B6	2E5B5	2E5B4	2E5B3	2E5B2	2E5B1	2E5B0
79H	DSP2 EQ5 B Coefficient 2	2E5B15	2E5B14	2E5B13	2E5B12	2E5B11	2E5B10	2E5B9	2E5B8
7AH	DSP2 EQ5 B Coefficient 3	0	0	0	0	2E5B19	2E5B18	2E5B17	2E5B16
7BH	DSP2 EQ5 C Coefficient 1	2E5C7	2E5C6	2E5C5	2E5C4	2E5C3	2E5C2	2E5C1	2E5C0
7CH	DSP2 EQ5 C Coefficient 2	2E5C15	2E5C14	2E5C13	2E5C12	2E5C11	2E5C10	2E5C9	2E5C8
7DH	DSP2 EQ5 C Coefficient 3	0	0	0	0	2E5C19	2E5C18	2E5C17	2E5C16

■ Register Definitions of Fundamental Function

Addr	Register Name	D7	D6	D5	D4	D3	D2	D1	D0
00H	SAR Control	CTM1	CTM0	SA2SEL	SA2	PMSAR	0	0	0
	R/W	R/W	R/W	R/W	R/W	R/W	RD	RD	RD
	Default	0	0	0	0	0	0	0	0

PMSAR: SAR ADC Power Management
 0: Power-down (default)
 1: Power-up

SA2: SAIN2 Enable
 0: SAIN2 Disable (default)
 1: SAIN2 Enable

SA2SEL: SAIN2 Output Configuration setting (Table 43)
 0: Setting for DSP1 (default)
 1: Setting for DSP2

CTM1-0: Cycle Time setting (Table 45)
 Default: "00"

Addr	Register Name	D7	D6	D5	D4	D3	D2	D1	D0
01H	Signal Path	ALMT1	ALMT2	SPC1	SPC0	0	SEL1	0	SEL0
	R/W	R/W	R/W	R/W	R/W	RD	R/W	RD	R/W
	Default	0	0	0	0	0	0	0	0

SEL1-0: DSP Input setting (Table 19)
 00: Analog-in (default)
 01: Digital-in
 10: Mix

SPC1-0: Line Output Configuration setting (Table 21, Table 22, Table 23, Table 24)
 Those bits select the output mode to 2-channels mode, 2.1-channels mode, and 4-channels mode.
 Default: "00"

ALMT2: DSP2 Limiter Enable
 0: Limiter Disable (default)
 1: Limiter Enable

ALMT1: DSP1 Limiter Enable
 0: Limiter Disable (default)
 1: Limiter Enable

Addr	Register Name	D7	D6	D5	D4	D3	D2	D1	D0
02H	Mode Setting 1	FS3	FS2	FS1	FS0	PLL3	PLL2	PLL1	PLL0
	R/W	R/W	R/W	R/W	R/W	R/W	R/W	R/W	R/W
	Default	0	0	0	0	0	0	0	0

PLL3-0: PLL Reference Clock Select (Table 4)
 Default: "0000" (LRCK pin)

FS3-0: Sampling Frequency Select (Table 5, Table 7) and MCKI Frequency Select (Table 10, Table 12)
 FS3-0 bits select sampling frequency at PLL mode and MCKI frequency at EXT mode.

Addr	Register Name	D7	D6	D5	D4	D3	D2	D1	D0
03H	Mode Setting 2	BCKO	M/S	BCKP	MSBS	0	DIF2	DIF1	DIF0
	R/W	R/W	R/W	R/W	R/W	RD	R/W	R/W	R/W
	Default	1	0	0	0	0	0	1	1

DIF2-0: Audio Interface Format (Table 15)

Default: "011" (I²S)

MSBS: LRCK Polarity at DSP Mode (Table 16, Table 17, Table 18)

0: The rising edge ("↑") of LRCK is half clock of BICK before the channel change. (default)

1: The rising edge ("↑") of LRCK is one clock of BICK before the channel change.

BCKP: BICK Polarity at DSP Mode (Table 16, Table 17, Table 18)

0: SDTI is latched by the falling edge ("↓") of BICK. (default)

1: SDTI is latched by the rising edge ("↑") of BICK.

M/S: Master / Slave Mode Setting

0: Slave Mode (default)

1: Master Mode

BCKO: BICK Output Frequency Select at Master Mode (Table 9)

Addr	Register Name	D7	D6	D5	D4	D3	D2	D1	D0
04H	Power Management	PMPLL	0	PMLO2	PMLO1	PMDIG	PWXTL	0	PMADC
	R/W	R/W	RD	R/W	R/W	R/W	R/W	RD	R/W
	Default	0	0	0	0	0	0	0	0

PMADC: ADC Power Management

0: Power-down (default)

1: Power-up

PWXTL: The power management of the crystal oscillation circuit

0: Power OFF (default)

1: Power ON

PMDIG: DSP & DAC Digital Power Management

0: Power-down (default)

1: Power-up

PMLO1: Line Out1 Power Management and External Mute Control

0: Power-down (default)

1: Power-up

PMLO2: Line Out2 Power Management and External Mute Control

0: Power-down (default)

1: Power-up

PMPLL: PLL Power Management

0: EXT Mode and Power-Down (default)

1: PLL Mode and Power-up

Addr	Register Name	D7	D6	D5	D4	D3	D2	D1	D0
05H	Lch DATT	L7	L6	L5	L4	L3	L2	L1	L0
06H	Rch DATT	R7	R6	R5	R4	R3	R2	R1	R0
	R/W	R/W	R/W	R/W	R/W	R/W	R/W	R/W	R/W
	Default	1	1	1	1	1	1	1	1

L7-0, R7-0: Digital Attenuation Control (Table 25)
Default: “FFH” (MUTE)

Addr	Register Name	D7	D6	D5	D4	D3	D2	D1	D0
07H	Gain Setting	1PSTG1	1PSTG0	1PREG1	1PREG0	2PSTG1	2PSTG0	2PREG1	2PREG0
	R/W	R/W	R/W	R/W	R/W	R/W	R/W	R/W	R/W
	Default	0	0	0	0	0	0	0	0

2PREG1-0: DSp2 Pre-Gain setting (Table 27)
Default: “00”

2PSTG1-0: DSP2 Post-Gain setting (Table 28)
Default: “00”

1PREG1-0: DSP1 Pre-Gain setting (Table 27)
Default: “00”

1PSTG1-0: DSP1 Post-Gain setting (Table 28)
Default: “00”

Addr	Register Name	D7	D6	D5	D4	D3	D2	D1	D0
08H	DSP1 Limiter Mode Control	1LFSTN	1ZELMN	1RGAIN1	1RGAIN0	1LMAT1	1LMAT0	1LMTH1	1LMTH0
	R/W	R/W	R/W	R/W	R/W	R/W	R/W	R/W	R/W
	Default	0	0	0	0	0	0	0	0

1LMTH1-0: DSP1 Limiter Detection Level / Recovery Counter Reset Level (Table 32)
Default: “00”

1LMAT1-0: DSP1 Limiter ATT Step (Table 33)
Default: “00”

1RGAIN1-0: DSP1 Recovery GAIN Step (Table 36)
Default: “00”

1ZELMN: DSP1 Zero Crossing Detection Enable at Limiter Operation
0: Enable (default)
1: Disable

1LFSTN: DSP1 Limiter functions when the output was bigger than full scale
0: When output is bigger than full scale, VOL value is changed instantly. (default)
1: The output is changed by the Limiter operation at the zero crossing point or at the zero crossing timeout.

Addr	Register Name	D7	D6	D5	D4	D3	D2	D1	D0
09H	DSP1 Timer Select	1RFST1	1RFST0	1WTM2	1WTM1	1WTM0	1ZTM1	1ZTM0	DVTM
	R/W	R/W	R/W	R/W	R/W	R/W	R/W	R/W	R/W
	Default	0	0	0	0	0	0	0	0

1RFST1-0: DSP1 First recovery Speed ([Table 38](#))
Default: "00" (4times)

1WTM2-0: DSP1 Recovery Waiting Period ([Table 35](#))
Default: "000" (128/fs)

1ZTM1-0: DSP1 Limiter/Recovery Operation Zero Crossing Timeout Period ([Table 34](#))
Default: "00" (128/fs)

DVTM: Digital Volume Transition Time Setting
0: 1061/fs (default)
1: 256/fs

This is the transition time between L/R7-0 bits = 00H and FFH.

Addr	Register Name	D7	D6	D5	D4	D3	D2	D1	D0
0AH	DSP1 Reference Level	1REF7	1REF6	1REF5	1REF4	1REF3	1REF2	1REF1	1REF0
	R/W	R/W	R/W	R/W	R/W	R/W	R/W	R/W	R/W
	Default	1	1	1	1	0	0	0	1

1REF7-0: DSP1 Reference Level at Recovery Operation ([Table 37](#))
Default: "F1H" (0dB)

Addr	Register Name	D7	D6	D5	D4	D3	D2	D1	D0
0BH	DSP2 Limiter Mode Control	2LFSTN	2ZELMN	2RGAIN1	2RGAIN0	2LMAT1	2LMAT0	2LMTH1	2LMTH0
	R/W	R/W	R/W	R/W	R/W	R/W	R/W	R/W	R/W
	Default	0	0	0	0	0	0	0	0

2LMTH1-0: DSP2 Limiter Detection Level / Recovery Counter Reset Level ([Table 32](#))
Default: "00"

2LMAT1-0: DSP2 Limiter ATT Step ([Table 33](#))
Default: "00"

2RGAIN1-0: DSP2 Recovery GAIN Step ([Table 36](#))
Default: "00"

2ZELMN: DSP2 Zero Crossing Detection Enable at Limiter Operation
0: Enable (default)
1: Disable

2LFSTN: DSP2 Limiter functions when the output was bigger than full scale
0: When output is bigger than full scale, VOL value is changed instantly. (default)
1: The output is changed by the Limiter operation at the zero crossing point or at the zero crossing timeout.

Addr	Register Name	D7	D6	D5	D4	D3	D2	D1	D0
0CH	DSP2 Timer Select	2RFST1	2RFST0	2WTM2	2WTM1	2WTM0	2ZTM1	2ZTM0	0
	R/W	R/W	R/W	R/W	R/W	R/W	R/W	R/W	RD
	Default	0	0	0	0	0	0	0	0

2RFST1-0: DSP2 First recovery Speed ([Table 38](#))

Default: "00" (4times)

2WTM2-0: DSP2 Recovery Waiting Period ([Table 35](#))

Default: "000" (128/fs)

2ZTM1-0: DSP2 Limiter/Recovery Operation Zero Crossing Timeout Period ([Table 34](#))

Default: "00" (128/fs)

Addr	Register Name	D7	D6	D5	D4	D3	D2	D1	D0
0DH	DSP2 Reference Level	2REF7	2REF6	2REF5	2REF4	2REF3	2REF2	2REF1	2REF0
	R/W	R/W	R/W	R/W	R/W	R/W	R/W	R/W	R/W
	Default	1	1	1	1	0	0	0	1

2REF7-0: DSP2 Reference Level at Recovery Operation ([Table 37](#))

Default: "F1H" (0dB)

■ Register Definitions of DSP1 Function

Each setting of the function is shown below. To distinguish DSP1 and DSP2, “1” is added to the head of each bit name for DSP1, and “2” is added for DSP2.

Addr	Register Name	D7	D6	D5	D4	D3	D2	D1	D0
0EH	HPF/LPF Setting	0	0	0	0	0	0	1FILSEL	1FILEN
	R/W	RD	RD	RD	RD	RD	RD	R/W	R/W
	Default	0	0	0	0	0	0	0	0

1FILEN: High Pass and Low Pass Filter Enable bit

0: HPF and LPF Disable (default)

1: HPF and LPF Enable

1FILSEL: HPF or LPF Select bit

0: LPF becomes effective (default)

1: HPF becomes effective

Addr	Register Name	D7	D6	D5	D4	D3	D2	D1	D0
0FH	DSP1 Filter A Coefficient 1	1FA7	1FA6	1FA5	1FA4	1FA3	1FA2	1FA1	1FA0
10H	DSP1 Filter A Coefficient 2	1FA15	1FA14	1FA13	1FA12	1FA11	1FA10	1FA9	1FA8
11H	DSP1 Filter A Coefficient 3	0	0	0	0	1FA19	1FA18	1FA17	1FA16
12H	DSP1 Filter B Coefficient 1	1FB7	1FB6	1FB5	1FB4	1FB3	1FB2	1FB1	1FB0
13H	DSP1 Filter B Coefficient 2	1FB15	1FB14	1FB13	1FB12	1FB11	1FB10	1FB9	1FB8
14H	DSP1 Filter B Coefficient 3	0	0	0	0	1FB19	1FB18	1FB17	1FB16
15H	DSP1 Filter C Coefficient 1	1FC7	1FC6	1FC5	1FC4	1FC3	1FC2	1FC1	1FC0
16H	DSP1 Filter C Coefficient 2	1FC15	1FC14	1FC13	1FC12	1FC11	1FC10	1FC9	1FC8
17H	DSP1 Filter C Coefficient 3	0	0	0	0	1FC19	1FC18	1FC17	1FC16
	R/W	R/W	R/W	R/W	R/W	R/W	R/W	R/W	R/W
	Default	0	0	0	0	0	0	0	0

1FA19-0, 1FB19-0, 1FC19-0: HPF and LPF Coefficient Setting bit

Default: “00000H”

Addr	Register Name	D7	D6	D5	D4	D3	D2	D1	D0
18H	DSP1 EQ Select	0	0	0	1EQ5	1EQ4	1EQ3	1EQ2	1EQ1
	R/W	RD	RD	RD	R/W	R/W	R/W	R/W	R/W
	Default	0	0	0	0	0	0	0	0

1EQ1: Equalizer 1 Coefficient Setting Enable

0: Disable (default)

1: Enable

When 1EQ1 bit is “1”, settings of 1E1A19-0, 1E1B19-0 and 1E1C19-0 bits are enabled. When 1EQ1 bit is “0”, the audio data passes this block by 0dB gain.

1EQ2: Equalizer 2 Coefficient Setting Enable

0: Disable (default)

1: Enable

When 1EQ2 bit is “1”, settings of 1E2A19-0, 1E2B19-0 and 1E2C19-0 bits are enabled. When 1EQ2 bit is “0”, the audio data passes this block by 0dB gain.

1EQ3: Equalizer 3 Coefficient Setting Enable

0: Disable (default)

1: Enable

When 1EQ3 bit is “1”, settings of 1E3A19-0, 1E3B19-0 and 1E3C19-0 bits are enabled. When 1EQ3 bit is “0”, the audio data passes this block by 0dB gain.

1EQ4: Equalizer 4 Coefficient Setting Enable

0: Disable (default)

1: Enable

When 1EQ4 bit is “1”, settings of 1E4A19-0, 1E4B19-0 and 1E4C19-0 bits are enabled. When 1EQ4 bit is “0”, the audio data passes this block by 0dB gain.

1EQ5: Equalizer 5 Coefficient Setting Enable

0: Disable (default)

1: Enable

When 1EQ5 bit is “1”, settings of 1E5A19-0, 1E5B19-0 and 1E5C19-0 bits are enabled. When 1EQ5 bit is “0”, the audio data passes this block by 0dB gain.

Addr	Register Name	D7	D6	D5	D4	D3	D2	D1	D0
19H	DSP1 EQ1 A Coefficient 1	1E1A7	1E1A6	1E1A5	1E1A4	1E1A3	1E1A2	1E1A1	1E1A0
1AH	DSP1 EQ1 A Coefficient 2	1E1A15	1E1A14	1E1A13	1E1A12	1E1A11	1E1A10	1E1A9	1E1A8
1BH	DSP1 EQ1 A Coefficient 3	0	0	0	0	1E1A19	1E1A18	1E1A17	1E1A16
1CH	DSP1 EQ1 B Coefficient 1	1E1B7	1E1B6	1E1B5	1E1B4	1E1B3	1E1B2	1E1B1	1E1B0
1DH	DSP1 EQ1 B Coefficient 2	1E1B15	1E1B14	1E1B13	1E1B12	1E1B11	1E1B10	1E1B9	1E1B8
1EH	DSP1 EQ1 B Coefficient 3	0	0	0	0	1E1B19	1E1B18	1E1B17	1E1B16
1FH	DSP1 EQ1 C Coefficient 1	1E1C7	1E1C6	1E1C5	1E1C4	1E1C3	1E1C2	1E1C1	1E1C0
20H	DSP1 EQ1 C Coefficient 2	1E1C15	1E1C14	1E1C13	1E1C12	1E1C11	1E1C10	1E1C9	1E1C8
21H	DSP1 EQ1 C Coefficient 3	0	0	0	0	1E1C19	1E1C18	1E1C17	1E1C16

Addr	Register Name	D7	D6	D5	D4	D3	D2	D1	D0
22H	DSP1 EQ2 A Coefficient 1	1E2A7	1E2A6	1E2A5	1E2A4	1E2A3	1E2A2	1E2A1	1E2A0
23H	DSP1 EQ2 A Coefficient 2	1E2A15	1E2A14	1E2A13	1E2A12	1E2A11	1E2A10	1E2A9	1E2A8
24H	DSP1 EQ2 A Coefficient 3	0	0	0	0	1E2A19	1E2A18	1E2A17	1E2A16
25H	DSP1 EQ2 B Coefficient 1	1E2B7	1E2B6	1E2B5	1E2B4	1E2B3	1E2B2	1E2B1	1E2B0
26H	DSP1 EQ2 B Coefficient 2	1E2B15	1E2B14	1E2B13	1E2B12	1E2B11	1E2B10	1E2B9	1E2B8
27H	DSP1 EQ2 B Coefficient 3	0	0	0	0	1E2B19	1E2B18	1E2B17	1E2B16
28H	DSP1 EQ2 C Coefficient 1	1E2C7	1E2C6	1E2C5	1E2C4	1E2C3	1E2C2	1E2C1	1E2C0
29H	DSP1 EQ2 C Coefficient 2	1E2C15	1E2C14	1E2C13	1E2C12	1E2C11	1E2C10	1E2C9	1E2C8
2AH	DSP1 EQ2 C Coefficient 3	0	0	0	0	1E2C19	1E2C18	1E2C17	1E2C16
2BH	DSP1 EQ3 A Coefficient 1	1E3A7	1E3A6	1E3A5	1E3A4	1E3A3	1E3A2	1E3A1	1E3A0
2CH	DSP1 EQ3 A Coefficient 2	1E3A15	1E3A14	1E3A13	1E3A12	1E3A11	1E3A10	1E3A9	1E3A8
2DH	DSP1 EQ3 A Coefficient 3	0	0	0	0	1E3A19	1E3A18	1E3A17	1E3A16
2EH	DSP1 EQ3 B Coefficient 1	1E3B7	1E3B6	1E3B5	1E3B4	1E3B3	1E3B2	1E3B1	1E3B0
2FH	DSP1 EQ3 B Coefficient 2	1E3B15	1E3B14	1E3B13	1E3B12	1E3B11	1E3B10	1E3B9	1E3B8
30H	DSP1 EQ3 B Coefficient 3	0	0	0	0	1E3B19	1E3B18	1E3B17	1E3B16
31H	DSP1 EQ3 C Coefficient 1	1E3C7	1E3C6	1E3C5	1E3C4	1E3C3	1E3C2	1E3C1	1E3C0
32H	DSP1 EQ3 C Coefficient 2	1E3C15	1E3C14	1E3C13	1E3C12	1E3C11	1E3C10	1E3C9	1E3C8
33H	DSP1 EQ3 C Coefficient 3	0	0	0	0	1E3C19	1E3C18	1E3C17	1E3C16
34H	DSP1 EQ4 A Coefficient 1	1E4A7	1E4A6	1E4A5	1E4A4	1E4A3	1E4A2	1E4A1	1E4A0
35H	DSP1 EQ4 A Coefficient 2	1E4A15	1E4A14	1E4A13	1E4A12	1E4A11	1E4A10	1E4A9	1E4A8
36H	DSP1 EQ4 A Coefficient 3	0	0	0	0	1E4A19	1E4A18	1E4A17	1E4A16
37H	DSP1 EQ4 B Coefficient 1	1E4B7	1E4B6	1E4B5	1E4B4	1E4B3	1E4B2	1E4B1	1E4B0
38H	DSP1 EQ4 B Coefficient 2	1E4B15	1E4B14	1E4B13	1E4B12	1E4B11	1E4B10	1E4B9	1E4B8
39H	DSP1 EQ4 B Coefficient 3	0	0	0	0	1E4B19	1E4B18	1E4B17	1E4B16
3AH	DSP1 EQ4 C Coefficient 1	1E4C7	1E4C6	1E4C5	1E4C4	1E4C3	1E4C2	1E4C1	1E4C0
3BH	DSP1 EQ4 C Coefficient 2	1E4C15	1E4C14	1E4C13	1E4C12	1E4C11	1E4C10	1E4C9	1E4C8
3CH	DSP1 EQ4 C Coefficient 3	0	0	0	0	1E4C19	1E4C18	1E4C17	1E4C16

Addr	Register Name	D7	D6	D5	D4	D3	D2	D1	D0
3DH	DSP1 EQ5 A Coefficient 1	1E5A7	1E5A6	1E5A5	1E5A4	1E5A3	1E5A2	1E5A1	1E5A0
3EH	DSP1 EQ5 A Coefficient 2	1E5A15	1E5A14	1E5A13	1E5A12	1E5A11	1E5A10	1E5A9	1E5A8
3FH	DSP1 EQ5 A Coefficient 3	0	0	0	0	1E5A19	1E5A18	1E5A17	1E5A16
40H	DSP1 EQ5 B Coefficient 1	1E5B7	1E5B6	1E5B5	1E5B4	1E5B3	1E5B2	1E5B1	1E5B0
41H	DSP1 EQ5 B Coefficient 2	1E5B15	1E5B14	1E5B13	1E5B12	1E5B11	1E5B10	1E5B9	1E5B8
42H	DSP1 EQ5 B Coefficient 3	0	0	0	0	1E5B19	1E5B18	1E5B17	1E5B16
43H	DSP1 EQ5 C Coefficient 1	1E5C7	1E5C6	1E5C5	1E5C4	1E5C3	1E5C2	1E5C1	1E5C0
44H	DSP1 EQ5 C Coefficient 2	1E5C15	1E5C14	1E5C13	1E5C12	1E5C11	1E5C10	1E5C9	1E5C8
45H	DSP1 EQ5 C Coefficient 3	0	0	0	0	1E5C19	1E5C18	1E5C17	1E5C16
	R/W	R/W	R/W	R/W	R/W	R/W	R/W	R/W	R/W
	Default	0	0	0	0	0	0	0	0

1E1A19-0, 1E1B19-0, 1E1C19-0: Equalizer 1 Coefficient (20-bit x3)
Default: "00000H"

1E2A19-0, 1E2B19-0, 1E2C19-0: Equalizer 2 Coefficient (20-bit x3)
Default: "00000H"

1E3A19-0, 1E3B19-0, 1E3C19-0: Equalizer 3 Coefficient (20-bit x3)
Default: "00000H"

1E4A19-0, 1E4B19-0, 1E4C19-0: Equalizer 4 Coefficient (20-bit x3)
Default: "00000H"

1E5A19-0, 1E5B19-0, 1E5C19-0: Equalizer 5 Coefficient (20-bit x3)
Default: "00000H"

■ Register Definitions of DSP2 Function

Each setting of the function is shown below. To distinguish DSP1 and DSP2, “1” is added to the head of each bit name for DSP1, and “2” is added for DSP2.

Addr	Register Name	D7	D6	D5	D4	D3	D2	D1	D0
46H	HPF/LPF Setting	0	0	0	0	0	0	2FILSEL	2FILEN
	R/W	RD	RD	RD	RD	RD	RD	R/W	R/W
	Default	0	0	0	0	0	0	0	0

2FILEN: High Pass and Low Pass Filter Enable bit

0: HPF and LPF Disable (default)

1: HPF and LPF Enable

2FILSEL: HPF or LPF Select bit

0: LPF becomes effective (default)

1: HPF becomes effective

Addr	Register Name	D7	D6	D5	D4	D3	D2	D1	D0
47H	DSP2 Filter A Coefficient 1	2FA7	2FA6	2FA5	2FA4	2FA3	2FA2	2FA1	2FA0
48H	DSP2 Filter A Coefficient 2	2FA15	2FA14	2FA13	2FA12	2FA11	2FA10	2FA9	2FA8
49H	DSP2 Filter A Coefficient 3	0	0	0	0	2FA19	2FA18	2FA17	2FA16
4AH	DSP2 Filter B Coefficient 1	2FB7	2FB6	2FB5	2FB4	2FB3	2FB2	2FB1	2FB0
4BH	DSP2 Filter B Coefficient 2	2FB15	2FB14	2FB13	2FB12	2FB11	2FB10	2FB9	2FB8
4CH	DSP2 Filter B Coefficient 3	0	0	0	0	2FB19	2FB18	2FB17	2FB16
4DH	DSP2 Filter C Coefficient 1	2FC7	2FC6	2FC5	2FC4	2FC3	2FC2	2FC1	2FC0
4EH	DSP2 Filter C Coefficient 2	2FC15	2FC14	2FC13	2FC12	2FC11	2FC10	2FC9	2FC8
4FH	DSP2 Filter C Coefficient 3	0	0	0	0	2FC19	2FC18	2FC17	2FC16
	R/W	R/W	R/W	R/W	R/W	R/W	R/W	R/W	R/W
	Default	0	0	0	0	0	0	0	0

2FA19-0, 2FB19-0, 2FC19-0: HPF and LPF Coefficient Setting bit

Default: “00000H”

Addr	Register Name	D7	D6	D5	D4	D3	D2	D1	D0
50H	DSP2 EQ Select	0	0	0	2EQ5	2EQ4	2EQ3	2EQ2	2EQ1
	R/W	RD	RD	RD	R/W	R/W	R/W	R/W	R/W
	Default	0	0	0	0	0	0	0	0

2EQ1: Equalizer 1 Coefficient Setting Enable

0: Disable (default)

1: Enable

When 2EQ1 bit is “1”, settings of 2E1A19-0, 2E1B19-0 and 2E1C19-0 bits are enabled. When 2EQ1 bit is “0”, the audio data passes this block by 0dB gain.

2EQ2: Equalizer 2 Coefficient Setting Enable

0: Disable (default)

1: Enable

When 2EQ2 bit is “1”, settings of 2E2A19-0, 2E2B19-0 and 2E2C19-0 bits are enabled. When 2EQ2 bit is “0”, the audio data passes this block by 0dB gain.

2EQ3: Equalizer 3 Coefficient Setting Enable

0: Disable (default)

1: Enable

When 2EQ3 bit is “1”, settings of 2E3A19-0, 2E3B19-0 and 2E3C19-0 bits are enabled. When 2EQ3 bit is “0”, the audio data passes this block by 0dB gain.

2EQ4: Equalizer 4 Coefficient Setting Enable

0: Disable (default)

1: Enable

When 2EQ4 bit is “1”, settings of 2E4A19-0, 2E4B19-0 and 2E4C19-0 bits are enabled. When 2EQ4 bit is “0”, the audio data passes this block by 0dB gain.

2EQ5: Equalizer 5 Coefficient Setting Enable

0: Disable (default)

1: Enable

When 2EQ5 bit is “1”, settings of 2E5A19-0, 2E5B19-0 and 2E5C19-0 bits are enabled. When 2EQ5 bit is “0”, the audio data passes this block by 0dB gain.

Addr	Register Name	D7	D6	D5	D4	D3	D2	D1	D0
51H	DSP2 EQ1 A Coefficient 1	2E1A7	2E1A6	2E1A5	2E1A4	2E1A3	2E1A2	2E1A1	2E1A0
52H	DSP2 EQ1 A Coefficient 2	2E1A15	2E1A14	2E1A13	2E1A12	2E1A11	2E1A10	2E1A9	2E1A8
53H	DSP2 EQ1 A Coefficient 3	0	0	0	0	2E1A19	2E1A18	2E1A17	2E1A16
54H	DSP2 EQ1 B Coefficient 1	2E1B7	2E1B6	2E1B5	2E1B4	2E1B3	2E1B2	2E1B1	2E1B0
55H	DSP2 EQ1 B Coefficient 2	2E1B15	2E1B14	2E1B13	2E1B12	2E1B11	2E1B10	2E1B9	2E1B8
56H	DSP2 EQ1 B Coefficient 3	0	0	0	0	2E1B19	2E1B18	2E1B17	2E1B16
57H	DSP2 EQ1 C Coefficient 1	2E1C7	2E1C6	2E1C5	2E1C4	2E1C3	2E1C2	2E1C1	2E1C0
58H	DSP2 EQ1 C Coefficient 2	2E1C15	2E1C14	2E1C13	2E1C12	2E1C11	2E1C10	2E1C9	2E1C8
59H	DSP2 EQ1 C Coefficient 3	0	0	0	0	2E1C19	2E1C18	2E1C17	2E1C16

Addr	Register Name	D7	D6	D5	D4	D3	D2	D1	D0
5AH	DSP2 EQ2 A Coefficient 1	2E2A7	2E2A6	2E2A5	2E2A4	2E2A3	2E2A2	2E2A1	2E2A0
5BH	DSP2 EQ2 A Coefficient 2	2E2A15	2E2A14	2E2A13	2E2A12	2E2A11	2E2A10	2E2A9	2E2A8
5CH	DSP2 EQ2 A Coefficient 3	0	0	0	0	2E2A19	2E2A18	2E2A17	2E2A16
5DH	DSP2 EQ2 B Coefficient 1	2E2B7	2E2B6	2E2B5	2E2B4	2E2B3	2E2B2	2E2B1	2E2B0
5EH	DSP2 EQ2 B Coefficient 2	2E2B15	2E2B14	2E2B13	2E2B12	2E2B11	2E2B10	2E2B9	2E2B8
5FH	DSP2 EQ2 B Coefficient 3	0	0	0	0	2E2B19	2E2B18	2E2B17	2E2B16
60H	DSP2 EQ2 C Coefficient 1	2E2C7	2E2C6	2E2C5	2E2C4	2E2C3	2E2C2	2E2C1	2E2C0
61H	DSP2 EQ2 C Coefficient 2	2E2C15	2E2C14	2E2C13	2E2C12	2E2C11	2E2C10	2E2C9	2E2C8
62H	DSP2 EQ2 C Coefficient 3	0	0	0	0	2E2C19	2E2C18	2E2C17	2E2C16
63H	DSP2 EQ3 A Coefficient 1	2E3A7	2E3A6	2E3A5	2E3A4	2E3A3	2E3A2	2E3A1	2E3A0
64H	DSP2 EQ3 A Coefficient 2	2E3A15	2E3A14	2E3A13	2E3A12	2E3A11	2E3A10	2E3A9	2E3A8
65H	DSP2 EQ3 A Coefficient 3	0	0	0	0	2E3A19	2E3A18	2E3A17	2E3A16
66H	DSP2 EQ3 B Coefficient 1	2E3B7	2E3B6	2E3B5	2E3B4	2E3B3	2E3B2	2E3B1	2E3B0
67H	DSP2 EQ3 B Coefficient 2	2E3B15	2E3B14	2E3B13	2E3B12	2E3B11	2E3B10	2E3B9	2E3B8
68H	DSP2 EQ3 B Coefficient 3	0	0	0	0	2E3B19	2E3B18	2E3B17	2E3B16
69H	DSP2 EQ3 C Coefficient 1	2E3C7	2E3C6	2E3C5	2E3C4	2E3C3	2E3C2	2E3C1	2E3C0
6AH	DSP2 EQ3 C Coefficient 2	2E3C15	2E3C14	2E3C13	2E3C12	2E3C11	2E3C10	2E3C9	2E3C8
6BH	DSP2 EQ3 C Coefficient 3	0	0	0	0	2E3C19	2E3C18	2E3C17	2E3C16
6CH	DSP2 EQ4 A Coefficient 1	2E4A7	2E4A6	2E4A5	2E4A4	2E4A3	2E4A2	2E4A1	2E4A0
6DH	DSP2 EQ4 A Coefficient 2	2E4A15	2E4A14	2E4A13	2E4A12	2E4A11	2E4A10	2E4A9	2E4A8
6EH	DSP2 EQ4 A Coefficient 3	0	0	0	0	2E4A19	2E4A18	2E4A17	2E4A16
6FH	DSP2 EQ4 B Coefficient 1	2E4B7	2E4B6	2E4B5	2E4B4	2E4B3	2E4B2	2E4B1	2E4B0
70H	DSP2 EQ4 B Coefficient 2	2E4B15	2E4B14	2E4B13	2E4B12	2E4B11	2E4B10	2E4B9	2E4B8
71H	DSP2 EQ4 B Coefficient 3	0	0	0	0	2E4B19	2E4B18	2E4B17	2E4B16
72H	DSP2 EQ4 C Coefficient 1	2E4C7	2E4C6	2E4C5	2E4C4	2E4C3	2E4C2	2E4C1	2E4C0
73H	DSP2 EQ4 C Coefficient 2	2E4C15	2E4C14	2E4C13	2E4C12	2E4C11	2E4C10	2E4C9	2E4C8
74H	DSP2 EQ4 C Coefficient 3	0	0	0	0	2E4C19	2E4C18	2E4C17	2E4C16

Addr	Register Name	D7	D6	D5	D4	D3	D2	D1	D0
75H	DSP2 EQ5 A Coefficient 1	2E5A7	2E5A6	2E5A5	2E5A4	2E5A3	2E5A2	2E5A1	2E5A0
76H	DSP2 EQ5 A Coefficient 2	2E5A15	2E5A14	2E5A13	2E5A12	2E5A11	2E5A10	2E5A9	2E5A8
77H	DSP2 EQ5 A Coefficient 3	0	0	0	0	2E5A19	2E5A18	2E5A17	2E5A16
78H	DSP2 EQ5 B Coefficient 1	2E5B7	2E5B6	2E5B5	2E5B4	2E5B3	2E5B2	2E5B1	2E5B0
79H	DSP2 EQ5 B Coefficient 2	2E5B15	2E5B14	2E5B13	2E5B12	2E5B11	2E5B10	2E5B9	2E5B8
7AH	DSP2 EQ5 B Coefficient 3	0	0	0	0	2E5B19	2E5B18	2E5B17	2E5B16
7BH	DSP2 EQ5 C Coefficient 1	2E5C7	2E5C6	2E5C5	2E5C4	2E5C3	2E5C2	2E5C1	2E5C0
7CH	DSP2 EQ5 C Coefficient 2	2E5C15	2E5C14	2E5C13	2E5C12	2E5C11	2E5C10	2E5C9	2E5C8
7DH	DSP2 EQ5 C Coefficient 3	0	0	0	0	2E5C19	2E5C18	2E5C17	2E5C16
	R/W	R/W	R/W	R/W	R/W	R/W	R/W	R/W	R/W
	Default	0	0	0	0	0	0	0	0

2E1A19-0, 2E1B19-0, 2E1C19-0: Equalizer 1 Coefficient (20-bit x3)
Default: "00000H"

2E2A19-0, 2E2B19-0, 2E2C19-0: Equalizer 2 Coefficient (20-bit x3)
Default: "00000H"

2E3A19-0, 2E3B19-0, 2E3C19-0: Equalizer 3 Coefficient (20-bit x3)
Default: "00000H"

2E4A19-0, 2E4B19-0, 2E4C19-0: Equalizer 4 Coefficient (20-bit x3)
Default: "00000H"

2E5A19-0, 2E5B19-0, 2E5C19-0: Equalizer 5 Coefficient (20-bit x3)
Default: "00000H"

SYSTEM DESIGN

Figure 75 and Figure 76 shows the system connection diagram. An evaluation board (AKD4753) is available for fast evaluation as well as suggestions for peripheral circuitry.

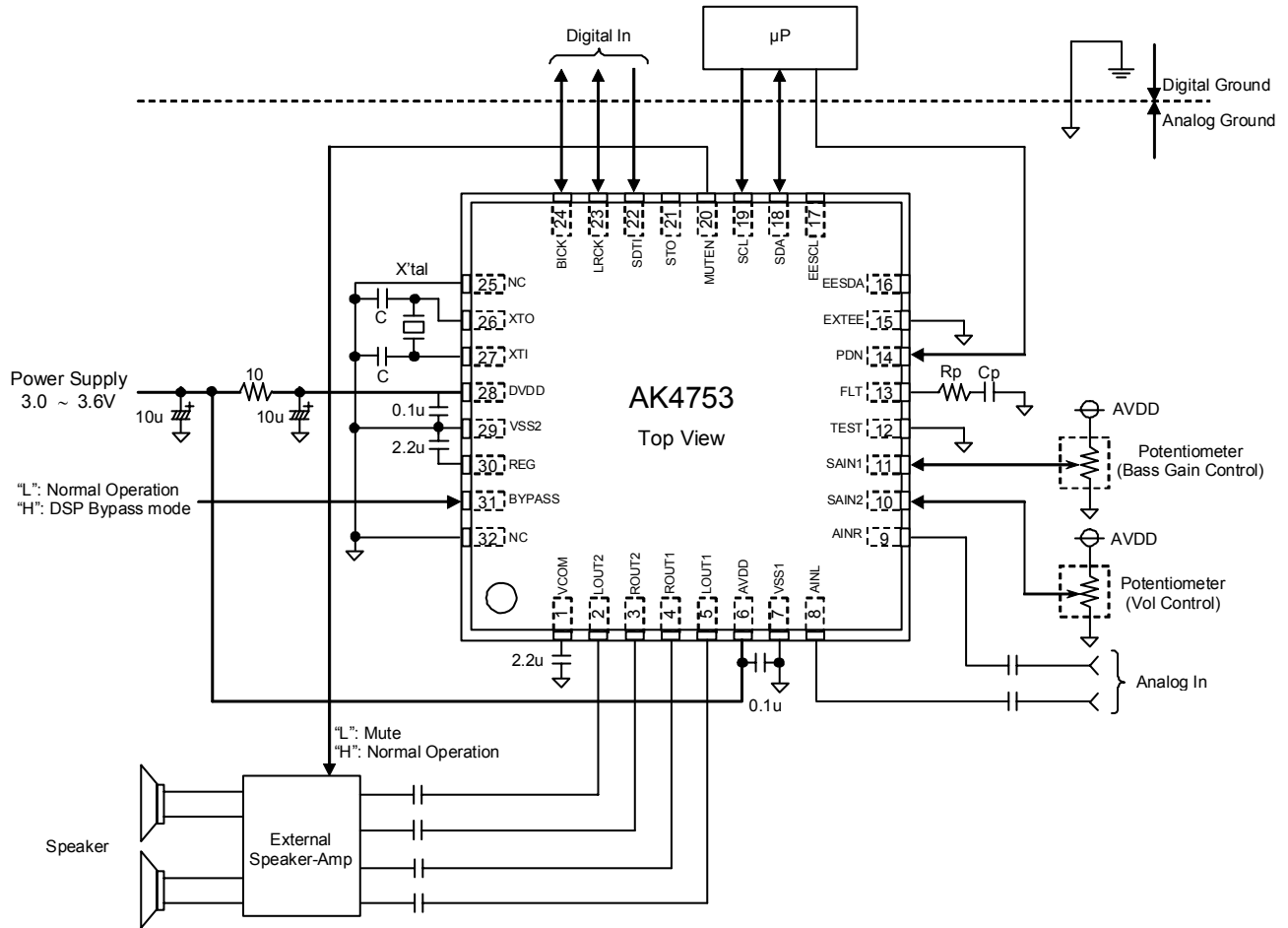

Notes:

- VSS1 and VSS2 of the AK4753 must be distributed separately from the ground of external controllers.
- All digital input pins must not be left floating.
- When the EXT mode is used (PMPLL bit = "0"), FLT pin can be open.
- When the PLL mode is used (PMPLL bit = "1"), "Cp" and "Rp" must be set according to Table 5.
- "C" value is dependent on the crystal.
- When the AK4753 is used in master mode, LRCK and BICK pins are floating before M/S bit is changed to "1". Therefore, around 100kΩ pull-up/down resistor must be connected to LRCK and BICK pins of the AK4753.
- 0.1μF capacitors at power supply pins should be ceramic capacitors. Other capacitors do not have specific types.

Figure 75. System Connection Diagram (Serial Control Mode: EXTEE pin = "L")

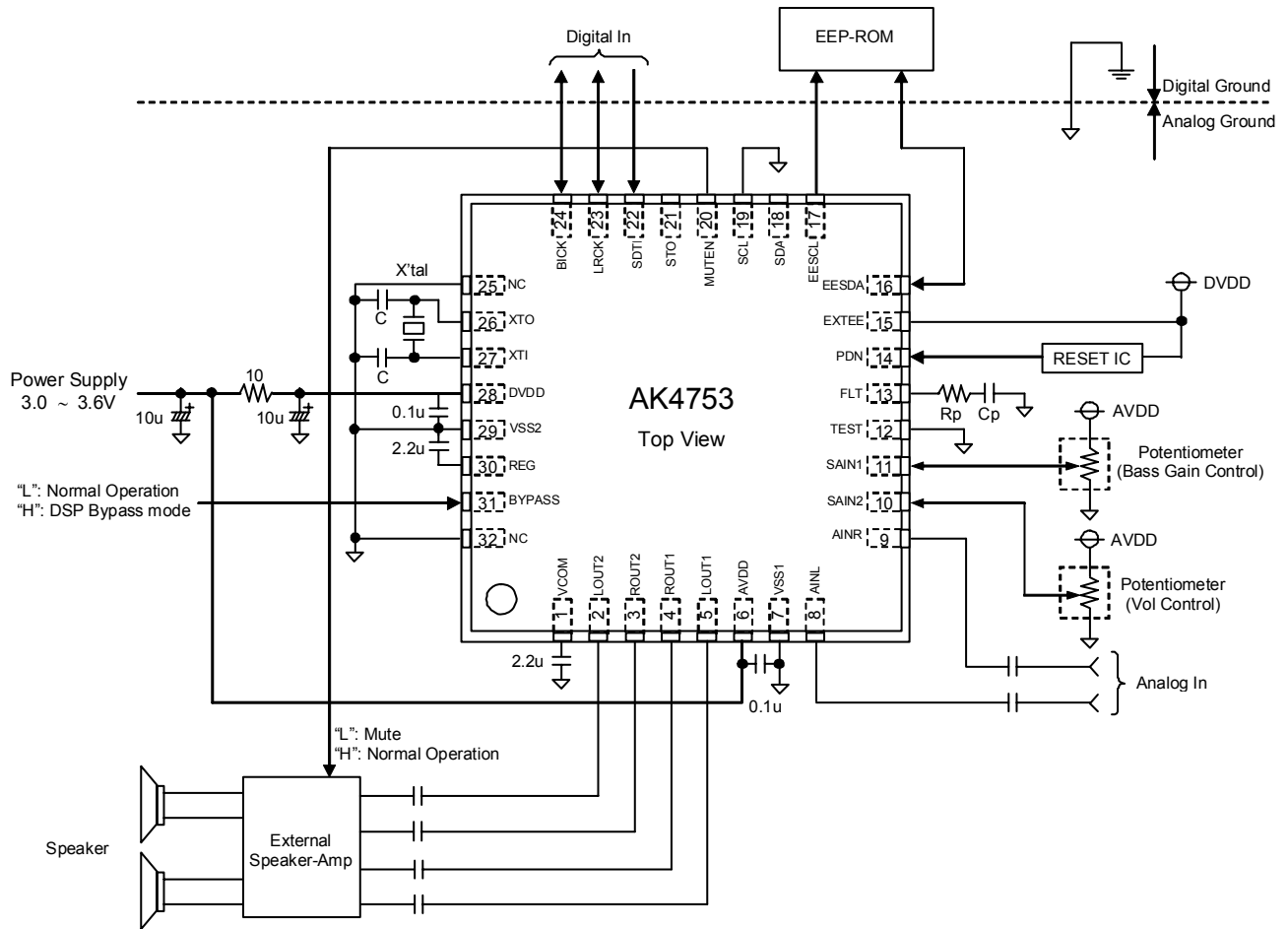

Notes:

- VSS1 and VSS2 of the AK4753 must be distributed separately from the ground of external controllers.
- All digital input pins must not be left floating.
- When the EXT mode is used (PMPLL bit = "0"), FLT pin can be open.
- When the PLL mode is used (PMPLL bit = "1"), "Cp" and "Rp" must be set according to Table 5.
- "C" value is dependent on the crystal.
- When the AK4753 is used in master mode, LRCK and BICK pins are floating before M/S bit is changed to "1". Therefore, around 100kΩ pull-up/down resistor must be connected to LRCK and BICK pins of the AK4753.
- 0.1μF capacitors at power supply pins should be ceramic capacitors. Other capacitors do not have specific types.

Figure 76. System Connection Diagram (EEP-ROM Download Mode: EXT EE pin = "H")

1. Grounding and Power Supply Decoupling

The AK4753 requires careful attention to power supply and grounding arrangements. If AVDD and DVDD are supplied separately, the power-up sequence is not critical. VSS1 and VSS2 of the AK4753 must be connected to the analog ground plane. System analog ground and digital ground must be connected together near to where the supplies are brought onto the printed circuit board. Decoupling capacitors must be as near to the AK4753 as possible, with the small value ceramic capacitor being the nearest.

2. Internal Regulated Voltage Power Supply

The input voltage to the REG pin is used as power supply (typ. 1.8V) for the internal digital circuit. A $2.2\mu\text{F}\pm 50\%$ ceramic capacitor connected between the REG and VSS2 pins eliminates the effects of high frequency noise. This capacitor in particular should be connected as close as possible to the pin. No load current may be drawn from the REG pin. All digital signals, especially clocks, should be kept away from the REG pin in order to avoid unwanted coupling into the AK4753.

3. Voltage Reference

VCOM is a signal ground of this chip. A $2.2\mu\text{F}\pm 50\%$ ceramic capacitor connected between this pin and the VSS1 pin eliminates the effects of high frequency noise. This capacitor in particular should be connected as close as possible to the pin. No load current may be drawn from the VCOM pin. All digital signals, especially clocks, must be kept away from the VCOM pin in order to avoid unwanted coupling into the AK4753.

4. Analog Inputs

The line inputs are single-ended. The input signal range scales with nominally at typ. 2.64V_{pp} ($0.8 \times \text{AVDD}$), centered around the internal signal ground ($\text{AVDD}/2$). Usually the input signal is AC coupled using a capacitor. The cut-off frequency is $f_c = 1/(2\pi RC)$. The AK4753 can accept input voltages from VSS1 to AVDD.

5. Analog Outputs

The input data format for the DAC is 2's complement. The output voltage is a positive full scale for 7FFFFFFH (@24-bit) and a negative full scale for 800000H (@24-bit). The ideal output is VCOM voltage for 000000H (@24-bit). The line outputs are single-ended or differential and centered at $\text{AVDD}/2$.

CONTROL SEQUENCE

■ Clock Setup

When any circuits of the AK4753 are powered-up, the clocks must be supplied.

1. PLL Master Mode

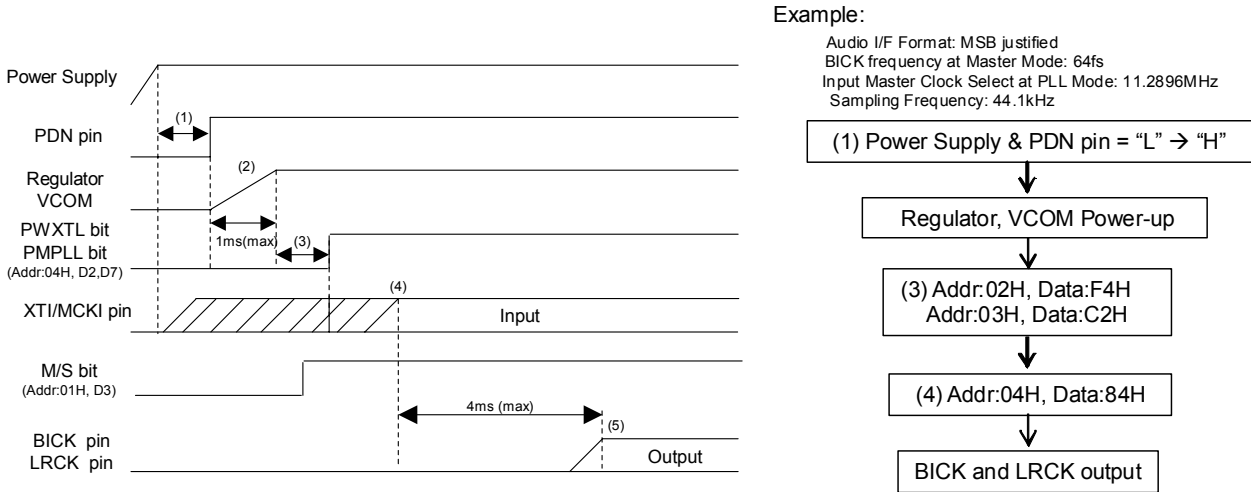

Figure 77. Clock Set Up Sequence (1)

<Example>

- (1) After Power Up, PDN pin “L” → “H”
 “L” time of 10ms or more is needed to reset the AK4753.
- (2) Power Up VCOM and Regulator
 Power up time is 1ms (max). To write register is forbidden during this period.
- (3) FS3-0, PLL3-0, BCKO, BCKP, MSBS and DIF2-0 bits must be set during this period.
- (4) PWXTL and PMPLL bits change from “0” to “1”. Then PLL starts after the crystal oscillator becomes stable or XT1/MCKI pin is supplied from an external source. PLL lock time is 4ms (max).
- (5) The AK4753 starts to output the LRCK and BICK clocks after the PLL became stable. Then normal operation starts.

2. PLL Slave Mode (LRCK or BICK pin)

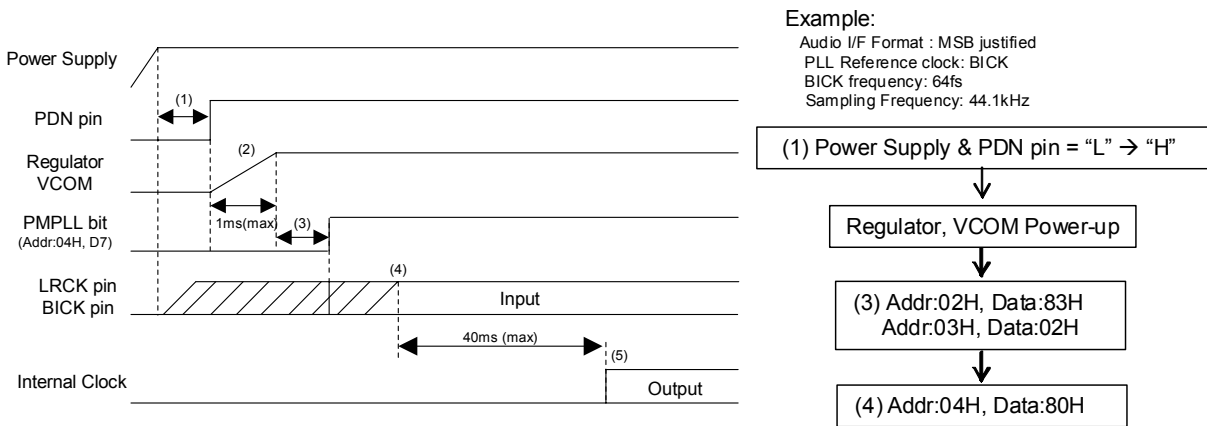

Figure 78. Clock Set Up Sequence (2)

<Example>

- (1) After Power Up: PDN pin "L" → "H"
"L" time of 10ms or more is needed to reset the AK4753.
- (2) Power Up VCOM and Regulator
Power up time is 1ms (max). To write register is forbidden during this period.
- (3) FS3-2, PLL3-0, BCKP, MSBS and DIF2-0 bits must be set during this period.
- (4) PWXTL and PMPLL bits change from "0" to "1". Then PLL starts after PLL reference clock (LRCK or BICK pin) is supplied from an external source. PLL lock time is 40ms (max) when LRCK is a PLL reference clock. PLL lock time is 4ms (max) when BICK is a PLL reference clock.
- (5) Normal operation starts after that the PLL is locked.

3. EXT Slave Mode

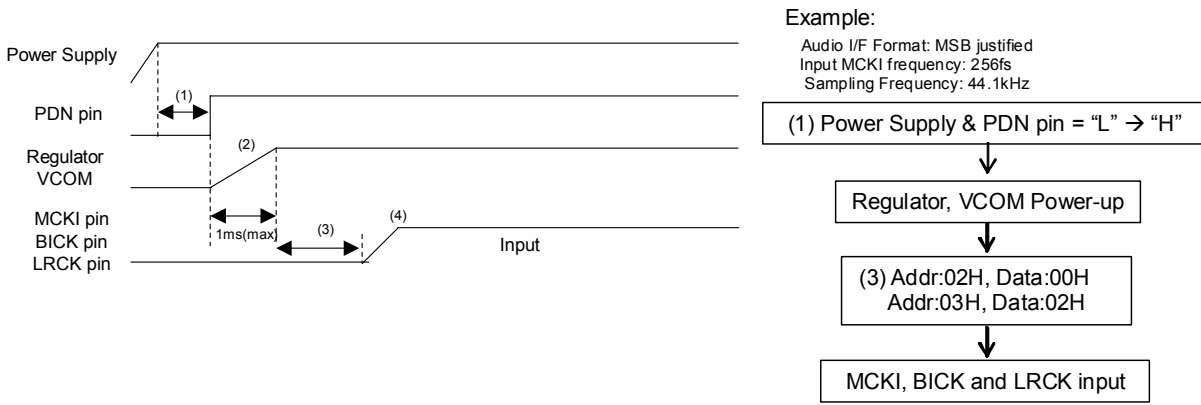

Figure 79. Clock Set Up Sequence (3)

<Example>

- (1) After Power Up: PDN pin "L" → "H"
 "L" time of 10ms or more is needed to reset the AK4753.
- (2) Power Up VCOM and Regulator
 Power up time is 1ms (max). To write register is forbidden during this period.
- (3) FS1-0, BCKP, MSBS and DIF2-0 bits must be set during this period.
- (4) Normal operation starts after the MCKI, LRCK and BICK are supplied.

4. EXT Master Mode

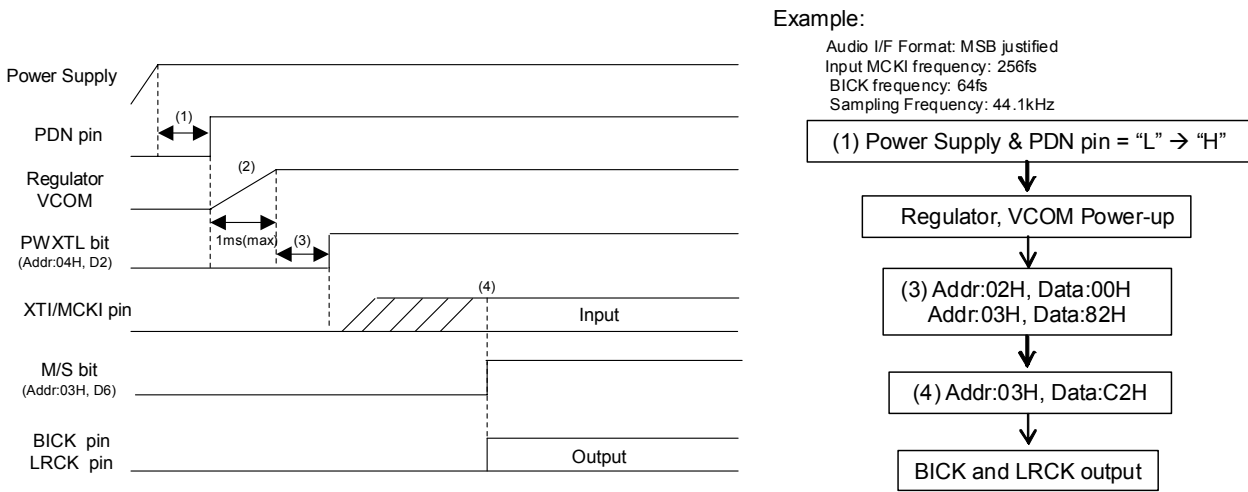

Figure 80. Clock Set Up Sequence (4)

<Example>

- (1) After Power Up: PDN pin "L" → "H"
 "L" time of 10ms or more is needed to reset the AK4753.
- (2) Power Up VCOM and Regulator
 Power up time is 1ms (max). To write register is forbidden during this period.
- (3) FS1-0, BCKO, BCKP, MSBS and DIF2-0 bits must be set during this period.
- (4) M/S bit should be set to "1" after the crystal oscillator becomes stable or MCKI is supplied from an external source. Then LRCK and BICK are output.

■ DAC Outputs

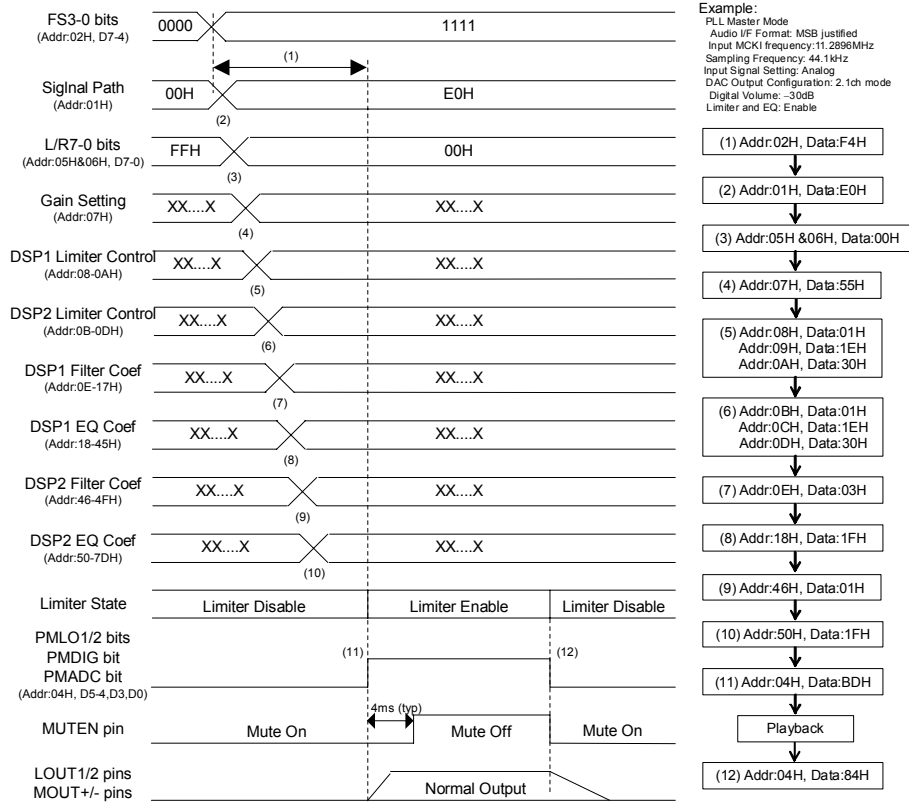

Figure 81. DAC Output Sequence

<Example>

At first, clocks must be supplied according to “Clock Set Up” sequence.

- (1) Set up a sampling frequency (FS3-0 bits). When the AK4753 is PLL mode, DAC of (11) must be powered-up in consideration of PLL lock time after a sampling frequency is changed.
- (2) Set up the path of Analog Input → DAC → 2.1ch Output and the ALMT1/2 bits: SEL1-0 bits = “00” → “00”, SPC1-0 bits = “00” → “10”, ALMT1/2 bits = “0” → “1”
- (3) Set up the output digital volume (Addr = 05H, 06H)
After DAC is powered-up, the digital volume changes from default value (Mute) to the register setting value by the soft transition.
- (4) Set up the Pre-Gain and Post-Gain: 1PREG1-0 bits = 2PREG1-0 bits = “00” → “01”, 1PSTG1-0 bits = 2PSTG1-0 bits = “00” → “01”
- (5) Set up 1LMTH1-0, 1LMAT1-0, 1RGAIN1-0, 1ZELMN, 1LFSTN, 1ZTM1-0, 1WTM2-0 and 1RFSN1-0 bits (Addr = 08H, 09H) and the REF value (Addr: 0AH) for Limiter of DSP1
Set up 2LMTH1-0, 2LMAT1-0, 2RGAIN1-0, 2ZELMN, 2LFSTN, 2ZTM1-0, 2WTM2-0 and 2RFSN1-0 bits (Addr = 0BH, 0CH) and the REF value (Addr: 0DH) for Limiter of DSP2
- (6) Set up Coefficient of LPF/HPF for DSP1 (Addr: 0EH ~ 17H)
- (7) Set up Coefficient of EQ for DSP1 (Addr: 18H ~ 45H)
- (8) Set up Coefficient of LPF/HPF for DSP2 (Addr: 46H ~ 4FH)
- (9) Set up Coefficient of EQ for DSP2 (Addr: 50H ~ 7DH)
- (10) Power Up the ADC, DSP, DAC and Line-Amp: PMADC = PMDIG = PMLO1 = PMLO2 bits = “0” → “1”
When ALMT1 bit or ALMT2 bit = “1”, Limiter operation starts from the gain set by L/R7-0 bits after the initialization cycle of ADC (1059/fs = 24ms @fs=44.1kHz).
- (11) Power Down the ADC, DSP, DAC and Line-Amp: PMADC = PMDIG = PMLO1 = PMLO2 bits = “1” → “0”

■ Stop of Clock

When the AK4753 is not used, the master clock can be stopped.

1. PLL Master mode

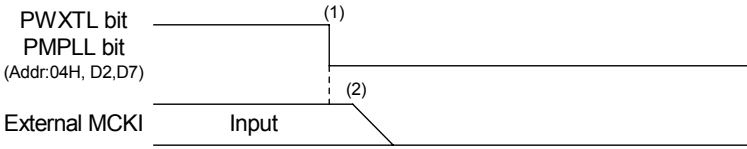

Example:

Audio I/F Format: MSB justified
BICK frequency at Master Mode: 64fs
Input Master Clock Select at PLL Mode: 11.2896MHz

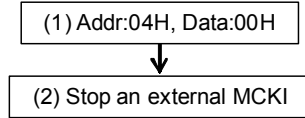
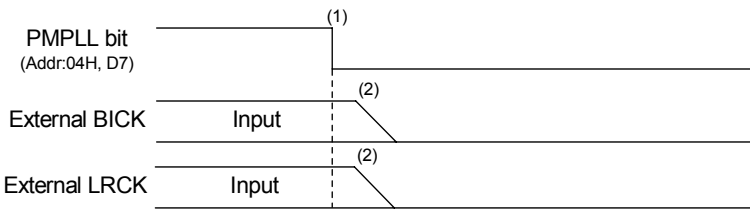

Figure 82. Clock Stopping Sequence (1)

<Example>

- (1) Power down Cristal Oscillator and PLL: PWXTL, PMPLL bits = “1” → “0”
- (2) Stop an external master clock.

2. PLL Slave Mode (LRCK or BICK pin)



Example

Audio I/F Format : MSB justified
PLL Reference clock: BICK
BICK frequency: 64fs

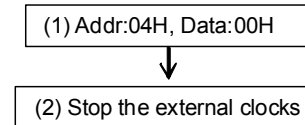
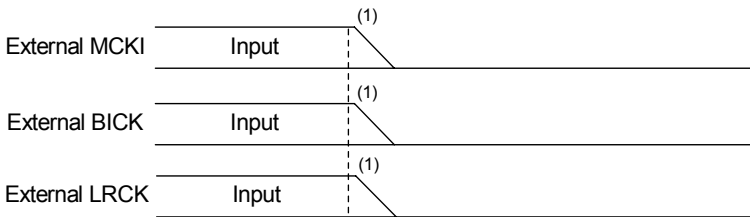

Figure 83. Clock Stopping Sequence (2)

<Example>

- (1) Power down PLL: PMPLL bit = “1” → “0”
- (2) Stop the external BICK and LRCK clocks.

3. EXT Slave Mode



Example

Audio I/F Format :MSB justified
Input MCKI frequency:256fs

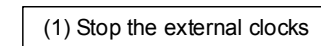

Figure 84. Clock Stopping Sequence (3)

<Example>

- (1) Stop the external MCKI, BICK and LRCK clocks.

4. EXT Master Mode

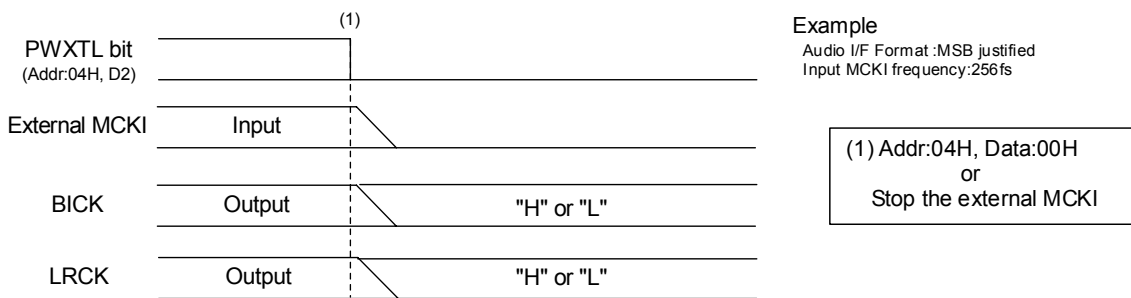

Figure 85. Clock Stopping Sequence (4)

<Example>

- (1) Power down Cristal oscillator (PWXTL bit = “1” → “0”) or stop MCKI clock. BICK and LRCK are fixed to “H” or “L”.

■ Power Down

Power supply current can also be shut down (typ. 1μA) by stopping clocks and setting PDN pin = “L”. When the PDN pin = “L”, the registers are initialized.

MARKING

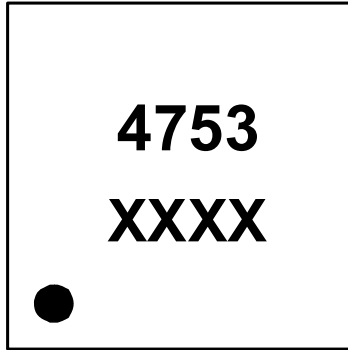

1

XXXX: Date code identifier (4 digits)

REVISION HISTORY

Date (Y/M/D)	Revision	Reason	Page	Contents
11/07/15	00	First Edition		
12/10/31	01	Specification Change	11	Switching Characteristics External Slave Mode BICK Input Timing, Period: 312.5ns → 312.5ns or 1/(126fs)s Note 16 was added.
13/02/06	02	Description Addition	21-23	<ul style="list-style-type: none"> ■ PLL Mode A detailed description was added: Note 23 and Note 24 were added. Table 6 was added.
13/03/21	03	Error Correction	21-23	<ul style="list-style-type: none"> ■ PLL Mode Description and Note 23: MCKI pin → XTI/MCKI pin Table 6 was changed.
13/04/04	04	Error Correction	23	<ul style="list-style-type: none"> ■ PLL Mode 3. Sampling Frequency setting in PLL Mode PLL reference clock pin: BICK pin → LRCK or BICK pin

IMPORTANT NOTICE

0. Asahi Kasei Microdevices Corporation (“AKM”) reserves the right to make changes to the information contained in this document without notice. When you consider any use or application of AKM product stipulated in this document (“Product”), please make inquiries the sales office of AKM or authorized distributors as to current status of the Products.
1. All information included in this document are provided only to illustrate the operation and application examples of AKM Products. AKM neither makes warranties or representations with respect to the accuracy or completeness of the information contained in this document nor grants any license to any intellectual property rights or any other rights of AKM or any third party with respect to the information in this document. You are fully responsible for use of such information contained in this document in your product design or applications. AKM ASSUMES NO LIABILITY FOR ANY LOSSES INCURRED BY YOU OR THIRD PARTIES ARISING FROM THE USE OF SUCH INFORMATION IN YOUR PRODUCT DESIGN OR APPLICATIONS.
2. The Product is neither intended nor warranted for use in equipment or systems that require extraordinarily high levels of quality and/or reliability and/or a malfunction or failure of which may cause loss of human life, bodily injury, serious property damage or serious public impact, including but not limited to, equipment used in nuclear facilities, equipment used in the aerospace industry, medical equipment, equipment used for automobiles, trains, ships and other transportation, traffic signaling equipment, equipment used to control combustions or explosions, safety devices, elevators and escalators, devices related to electric power, and equipment used in finance-related fields. Do not use Product for the above use unless specifically agreed by AKM in writing.
3. Though AKM works continually to improve the Product’s quality and reliability, you are responsible for complying with safety standards and for providing adequate designs and safeguards for your hardware, software and systems which minimize risk and avoid situations in which a malfunction or failure of the Product could cause loss of human life, bodily injury or damage to property, including data loss or corruption.
4. Do not use or otherwise make available the Product or related technology or any information contained in this document for any military purposes, including without limitation, for the design, development, use, stockpiling or manufacturing of nuclear, chemical, or biological weapons or missile technology products (mass destruction weapons). When exporting the Products or related technology or any information contained in this document, you should comply with the applicable export control laws and regulations and follow the procedures required by such laws and regulations. The Products and related technology may not be used for or incorporated into any products or systems whose manufacture, use, or sale is prohibited under any applicable domestic or foreign laws or regulations.
5. Please contact AKM sales representative for details as to environmental matters such as the RoHS compatibility of the Product. Please use the Product in compliance with all applicable laws and regulations that regulate the inclusion or use of controlled substances, including without limitation, the EU RoHS Directive. AKM assumes no liability for damages or losses occurring as a result of noncompliance with applicable laws and regulations.
6. Resale of the Product with provisions different from the statement and/or technical features set forth in this document shall immediately void any warranty granted by AKM for the Product and shall not create or extend in any manner whatsoever, any liability of AKM.
7. This document may not be reproduced or duplicated, in any form, in whole or in part, without prior written consent of AKM.