

Tous droits strictement réservés. Reproduction ou communication a des tiers interdite sous quelque forme que ce soit sans autorisation écrite du propriétaire. Propriete de c FCI. Droits de reproduction FCI.

All rights strictly reserved. Reproduction or issue to third parties in any form whatever is not permitted without written authority from the proprietor. Property of FCI. Copyright FCI.

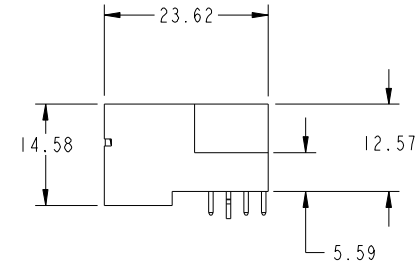

PRODUCT NO.	ROWS	POWER				SIGNAL				POWER			
		E1	P1	P2	P3	P4	1	2	3	4	P5	P6	E2
51730-175-- NOTE 3	D C B A												

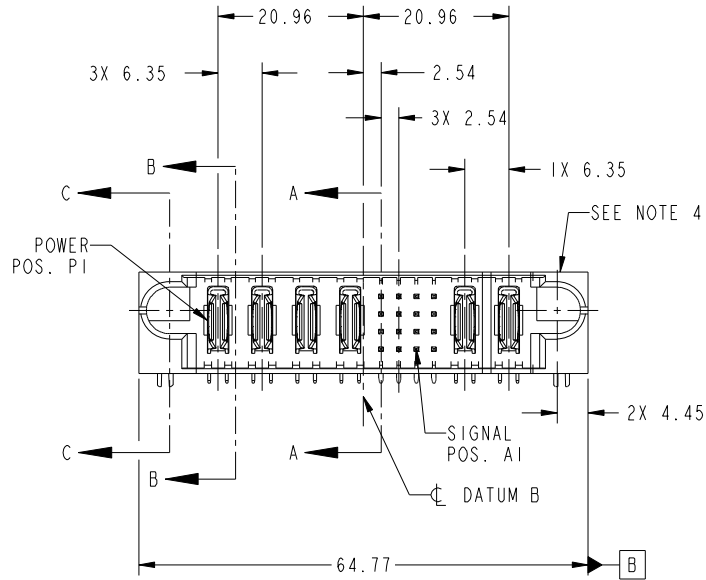

CODE	DIM "M" MATING LENGTH	CONTACT TYPE
T	[6.86]	SIGNAL
R	[6.86]	SIGNAL
S	[6.86]	SIGNAL
PA	[N/A]	POWER
HA	[N/A]	HOLD-DOWN
H	[5.59]	SIGNAL
F	[5.59]	SIGNAL
E	[5.59]	SIGNAL
G	[5.59]	SIGNAL

mat'l code				SEE NOTE		tolerances unless otherwise specified		CUSTOMER			
ltr	ecn no.	dr	date	linear	0.X ± 0.5	projection		COPY		www.fciconnect.com	
A	DG10-0160	SM	04/30/10	angles	0.XX ± 0.25			title		4P + 16S + 2P RIGHT ANGLE SOLDER HEADER	
				dr	0.XXX ± 0.1			product family		PwrBlade	code
				enrg	0° ± 2°	scale		size	dwg no	A	213
				chr		1:1		product no		51730-175	
				appd				sheet		1 of 4	
sheet index	revision sheet	A	A	A	A			cage code		22526	
1	2	3	4								

Pro/E

cage code 22526

Tous droits strictement reserves. Reproduction ou communication a des tiers interdite sous quelque forme que ce soit sans autorisation écrite du propriétaire. Propriete de c FCI. Droits de reproduction FCI.

All rights strictly reserved. Reproduction or issue to third parties in any form whatever is not permitted without written authority from the proprietor. Property of FCI. Copyright FCI.



PRODUCT NUMBER  
51730-175-  
NOTE: 3

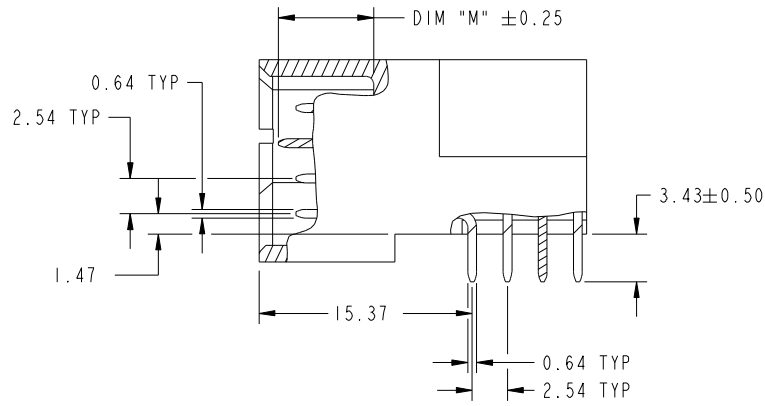

BROKEN-OUT SECTION A-A  
SCALE 2:1

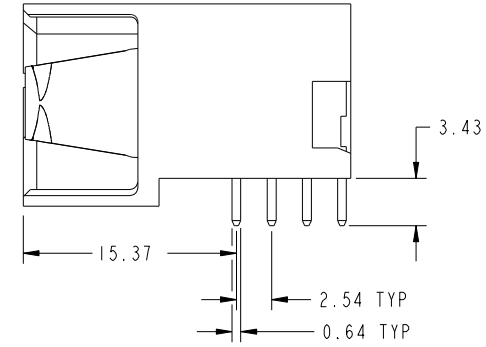

BROKEN-OUT SECTION B-B  
SCALE 2:1

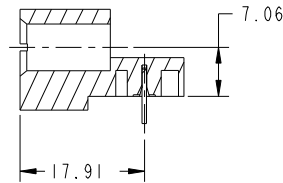

SECTION C-C

mat'l code		SEE NOTE		tolerances unless otherwise specified		CUSTOMER		FCI	
ltr	ecn no.	dr	date	linear	0.X ± 0.5	COPY		www.fciconnect.com	
A					0.XX ± 0.25	projection		title	
				angles	0.XXX ± 0.1			4P + 16S + 2P RIGHT ANGLE SOLDER HEADER	
				dr	0° ± 2°			product family PwrBlade code	
				enr	Shower Ma 04/30/10	scale		size	
				chr	Shower Ma 04/30/10	1:1		dwg no	
				appd	PM ZHENG 04/30/10			A 51730-175	
					JOSEPH HSIA 04/30/10			sheet	
sheet index	revision sheet							2 of 4	

cage code 22526

Pro/E

Tous droits strictement reserves. Reproduction ou communication a des tiers interdite sous quelque forme que ce soit sans autorisation écrite du propriétaire. Propriete de c FCI. Droits de reproduction FCI.



All rights strictly reserved. Reproduction or issue to third parties in any form whatever is not permitted without written authority from the proprietor. Property of FCI. Copyright FCI.

PRODUCT NUMBER  
51730-175-  
NOTE: 3

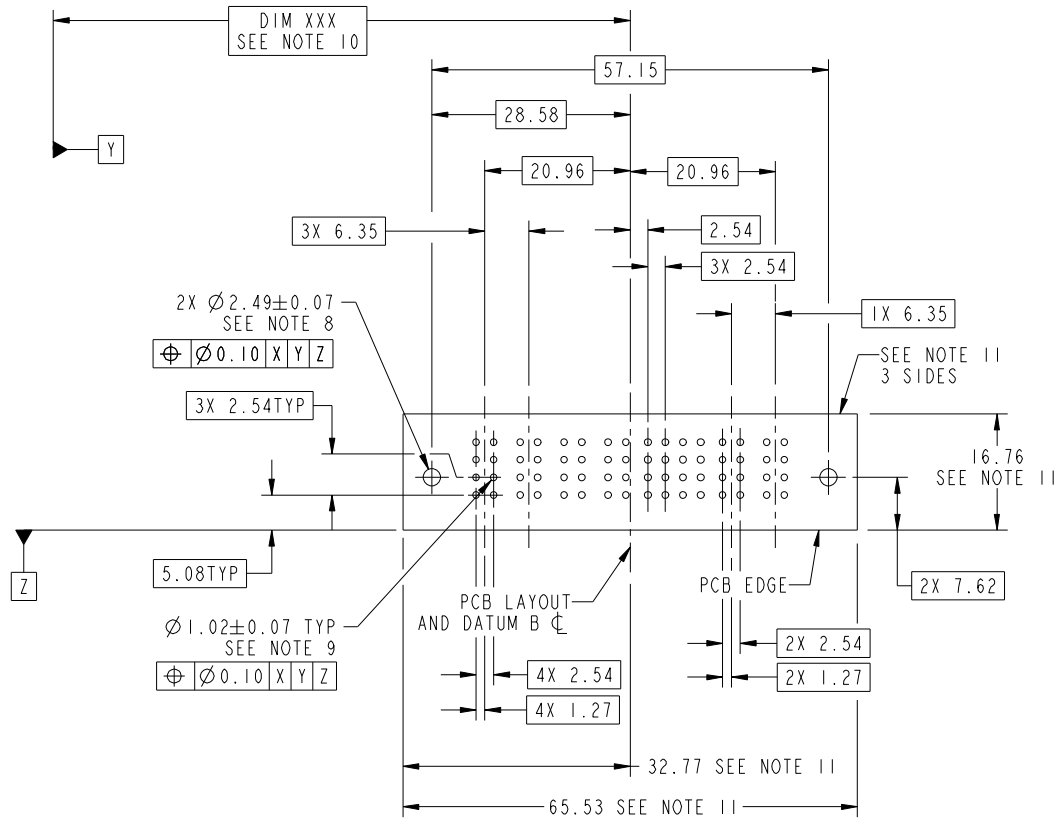

RECOMMENDED PCB LAYOUT

mat'l code		SEE NOTE		tolerances unless otherwise specified		CUSTOMER		 www.fciconnect.com	
ltr	ecn no.	dr	date	linear	0.X ± 0.5	COPY		title	
A					0.XX ± 0.25			4P + 16S + 2P RIGHT ANGLE SOLDER HEADER	
				angles	0.XXX ± 0.1			product family PwrBlade code	
		dr	Shower Ma	04/30/10	0° ± 2°	scale		size	
		enrg	Shower Ma	04/30/10		1:1		dwg no	
		chr	PM ZHENG	04/30/10				213	
		appd	JOSEPH HSIA	04/30/10				sheet	
sheet index		revision sheet						3 of 4	
								3 of 4	

cage code 22526

Pro/E

Tous droits strictement reserves. Reproduction ou communication a des tiers interdite sous quelque forme que ce soit sans autorisation écrite du propriétaire. Propriete de c FCI. Droits de reproduction FCI.



All rights strictly reserved. Reproduction or issue to third parties in any form whatever is not permitted without written authority from the proprietor. Property of FCI. Copyright FCI.

PRODUCT NUMBER  
51730-175--  
NOTE: 3

NOTES:

1. DIMENSIONS AND TOLERANCES ARE IN ACCORDANCE WITH ASME Y14.5M, 1994 UNLESS OTHERWISE SPECIFIED.

CONNECTOR NOTES:

- 2. HOUSING MATERIAL: UL 94 V-0 GLASS FILLED HIGH-TEMP THERMOPLASTIC  
POWER CONTACT MATERIAL: COPPER ALLOY  
SIGNAL PIN MATERIAL: COPPER ALLOY
- 3. SEE ITEM 1 & 2 IN PRINT 10064183 FOR PLATING SPEC OF 51730-175 AND 51730-175LF RESPECTIVELY.
- 4. MANUFACTURER'S NAME, DATE CODE AND OPTIONAL P/N TO APPEAR ON THIS SURFACE. THE P/N CAN BE OMITTED IF THERE IS NOT ENOUGH SPACE ON THIS SURFACE.
- 5. PRODUCT SPECIFICATION GS-12-149.  
APPLICATION SPECIFICATION BUS-20-067.
- 6. PACKAGED IN TRAYS.

PCB NOTES:

- 7. ALL HOLE DIAMETERS ARE FINISHED HOLE SIZE.
- 8. MOUNTING HOLES, WHERE APPLICABLE, ARE UNPLATED.
- 9.  $\varnothing 1.151 \pm 0.025$  DRILLED HOLES PLATED WITH 0.008 MIN SnPb OR Sn OVER 0.03 TO 0.08 Cu PLATING TO ACHIEVE  $\varnothing 1.02 \pm 0.07$  HOLE.
- 10. "DIM XXX" TO BE DETERMINED BY THE CUSTOMER.
- 11. CONNECTOR KEEP-OUT ZONE.

mat'l code				SEE NOTE		tolerances unless otherwise specified		CUSTOMER		FCI	
ltr	ecr no.	dr	date	linear	0.X ± 0.5	COPY		www.fciconnect.com		title	
A				linear	0.XX ± 0.25	projection		4P + 16S + 2P		RIGHT ANGLE SOLDER HEADER	
				angles	0.XXX ± 0.1			product family		PwrBlade code	
				dr	Shower Ma 04/30/10	MIM		size		213	
				enrg	Shower Ma 04/30/10			dwg no		sheet	
				chr	PM ZHENG 04/30/10	scale		A 51730-175		4 of 4	
				appd	JOSEPH HSIA 04/30/10	1:1					
sheet index		revision sheet									

cage code 22526

Pro/E