

PRODUCT NUMBER  
SEE TABLE

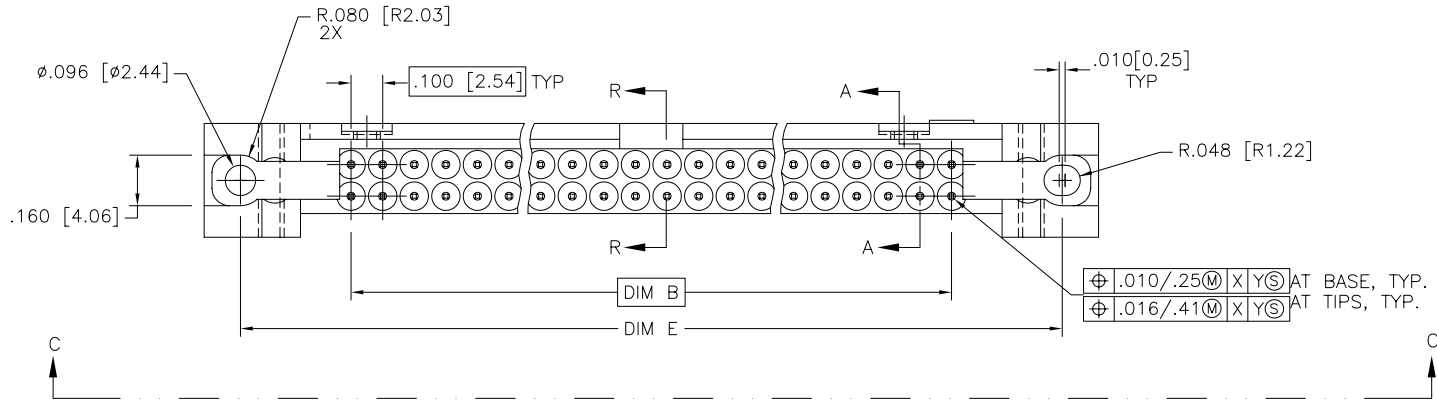

16-508-036,  
16-508-002, 16-508-131

mat'l. code		surface ISO 1302 ✓		tolerance ISO 406 ISO 1101		projection INCH/MM		product family QKE. HDR.	
H v91075 EPK 5/6/99		tolerances unless otherwise specified		.XX±.01/XX±0.3		INCH/MM		title QUICKIE HDR, STRIGHT 3 WALL LATCH & EJECT	
J V00871 EPK 4/11/00		angles		.XXX±.005/XX±0.13		scale 2:1		dwg no 66207	
K V01240 MDF 5/11/00		0'±2'		.XXXX±.0020/XXX±0.051		FCI		sheet 1 of 8 size A3	
L V06-0343 GIP 3/24/03		dr		J. SHREINER 11/15/90				type Product Customer Drawing	
M N05-0094 MHT 4/4/05		engr		M. SMIK 11/15/90					
N M06-0282 AGS 7/22/06		chr		M. SMYK 11/15/90					
P M07-0366 MHT 8/17/07		appd		M. SMYK 11/15/90					
sheet	revision	P	P	P	P	P	P	P	P
index	sheet	1	2	3	4	5	6	7	8

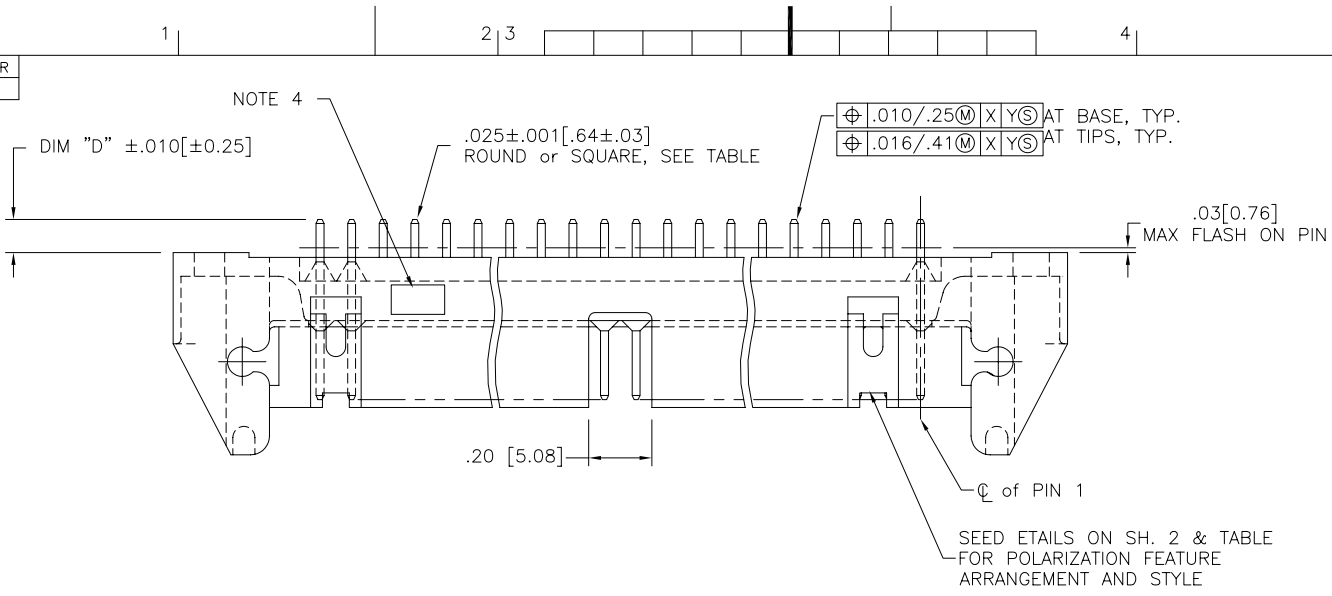

Copyright FCI

form: A3

PRODUCT NUMBER  
SEE TABLE

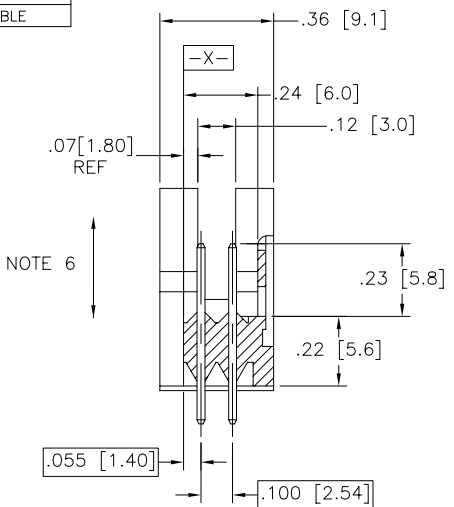

SECTION A-A  
ROTATED 90° CW

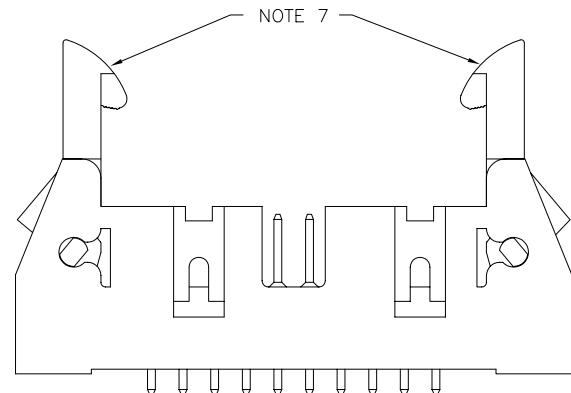

HEADER WITH LATCHES

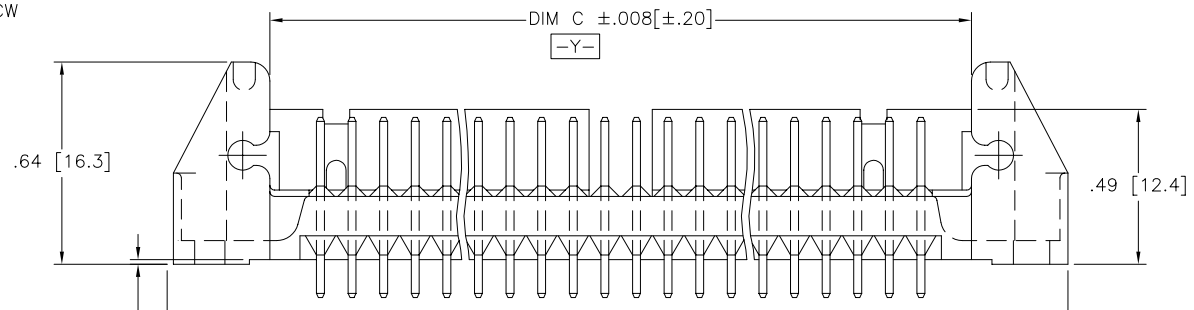

VIEW C-C

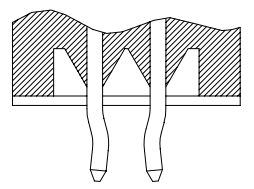

SECTION R-R

mat'l. code		surface ISO 1302 ✓		tolerance ISO 406 ISO 1101		projection ⊕		product family QKE. HDR.	
ltr		ecn no dr		date		tolerances unless otherwise specified		title	
P						linear XX±.01/XX±.03 XXX±.005/XXX±.013 XXXX±.0020/XXX±.0051		INCH/MM scale 2:1	
						0°±2'		QUICKIE HDR, STRIGHT 3 WALL LATCH & EJECT	
						dr J. SHREINER 11/15/90		dwg no sheet 2 of 8 size	
						enr M. SMIK 11/15/90		66207 A3	
						chr M. SMYK 11/15/90		type Product Customer Drawing	
						appd M. SMYK 11/15/90			
sheet index		revision sheet							



FCIconnect.com

Copyright FCI

PRODUCT NUMBER  
SEE TABLE

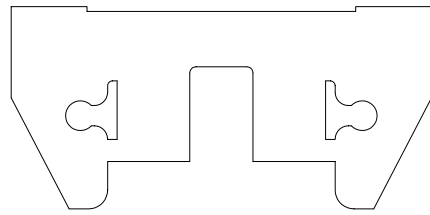

2X5  
STYLE A

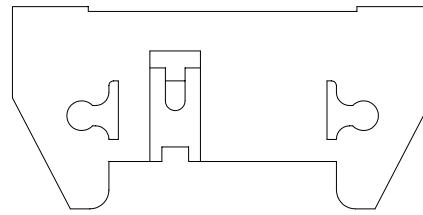

2X5  
STYLE B

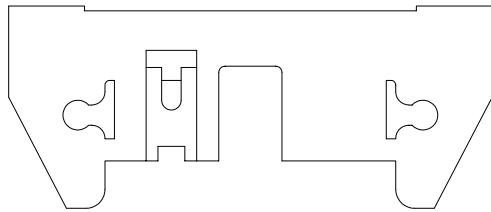

2X7  
STYLE C

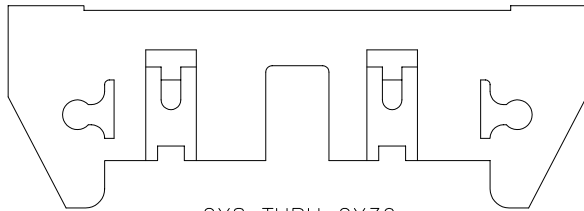

2X8 THRU 2X30  
2X10 SHOWN  
STYLE D

NOTES:

1. MOLDING MATERIAL: GLASS FILLED POLYESTER FLAME RETARDENT PER UL- 94V-0. COLOR: BLUE
2. PIN MATERIAL: PHOS BRONZE
- ③ 1" MAX DRAFT PERMISSIBLE ON ALL SURFACES UNLESS OTHERWISE SPECIFIED.
- ④ LOGO LOCATED APPROX, AS SHOWN.
5. RECOMMENDED MOUNTING SCREW: #2-56 FILLISTER HD. MACH. SCREW 3/8 LG. FOR 1/16" AND 3/32" BOARD 7/16" LG. FOR 1/8" BOARD.
6. 4 LBS/2.3 KG MIN PIN RETENTION IN BOTH DIRECTIONS. (SEE TABLE)
7. HEADER WITH LOW PROFILE (LP) LATCHES (SEE TABLE) ARE DESIGNED TO BE USED WITH FEMALE CONNECTORS WITHOUT STRAIN RELIEF. HEADERS WITH (STD) LATCHES (SEE TABLE) ARE DESIGNED TO BE USED WITH FEMALE CONNECTORS WITH STRAIN RELIEF.
8. PLATING ON LEAD-IN PORTION OF PIN IS MANUFACTURING OPTION.
9. SPECIAL LATCH HEIGHT TO BE USED WITH CARD CONNECTOR APPLICATION.
- ⑩ RETENTION FEATURE AVAILABLE ON CONNECTORS WITH .105/2.67, .120/3.05, OR .150/3.81 TAIL LENGTH RETENTIVE P/N INCLUDES THE LETTER "R" AFTER THE EXISTING P/N.  
EXAMPLE: 66207-XXX FOR EXISTING P/N  
66207-XXRX FOR RETENTIVE P/N.  
RETENTIVE FEATURE LOCATION - SEE TABLE  
SEE SECTION R-R ON SH. 2.
- ⑪ ADD "LF" SUFFIX AT THE END OF PART NUMBER FOR LEAD FREE.
12. THE HOUSING WILL WITHSTAND EXPOSURE TO 260°C PEAK TEMPERATURE FOR 15 SECONDS IN A WAVE SOLDER APPLICATION WITH A 1.5mm MINIMUM THICK CIRCUIT BOARD. SEE APPLICATION NOTES/PROCEDURES IF THEY ARE AVAILABLE.
- ⑬ THIS PRODUCT MEETS EUROPEAN UNION DIRECTIVES AND OTHER COUNTRY REGULATION AS DESCRIBED IN GS-22-008.
- ⑭ PLATING OPTIONS:  
MAY BE EITHER GOLD OR GXT PLATED AT MANUFACTURER'S OPTION.

FCI  
FCIconnect.com

Copyright FCI

mat'l. code		surface ISO 1302 ✓		tolerance ISO 406 ISO 1101		projection ⊕		product family QKE. HDR.	
ltr	ecn	no	dr	date	tolerances unless otherwise specified		title		
P					angles	linear	INCH/MM		QUICKIE HDR, STRIGHT 3 WALL LATCH & EJECT
					0°±2'	.XX±.01/XX±0.3 .XXX±.005/XX±0.13 .XXX±.0020/XXX±0.051	scale 2:1		66207
					dr	J. SHREINER	11/15/90	sheet 3 of 8 size	
					enfr	M. SMIK	11/15/90	A3	
					chr	M. SMYK	11/15/90	type Product Customer Drawing	
					appd	M. SMYK	11/15/90		
sheet index	revision sheet								

PRODUCT NO NOTE 11	SIZE	DIM A	DIM B	DIM C	DIM D	DIM E	LATCHES NOTE 7	STYLE	PIN SHAPE	PIN PLATING (NOTE 14)
66207-001	2 X 5	1.330/33.78	.400/10.16	.720/18.29	.105/2.67	1.100/27.94	NO	A	RND	30µ"/0.76µ Au OR GXT OVER 50µ"/1.27µ Ni
-002	2 X 7	1.530/38.86	.600/15.24	.920/23.37		1.300/33.02		C		
-003	2 X 8	1.630/41.40	.700/17.78	1.020/25.91		1.400/35.56		D		
-004	2 X 10	1.830/46.48	.900/22.86	1.220/30.99		1.600/40.64				
-005	2 X 13	2.130/54.10	1.200/30.48	1.520/38.61		1.900/48.26				
-006	2 X 17	2.530/64.26	1.600/40.64	1.920/48.77		2.300/58.42				
-007	2 X 20	2.830/71.88	1.900/48.26	2.220/56.39		2.600/66.04				
-008	2 X 25	3.330/84.58	2.400/60.96	2.720/69.09		3.100/78.74				
-009	2 X 30	3.830/97.28	2.900/73.66	3.220/81.79		3.600/91.44	NO	D		
-010	2 X 5	1.330/33.78	.400/10.16	.720/18.29		1.100/27.94	STD	A		
-011	2 X 7	1.530/38.86	.600/15.24	.920/23.37		1.300/33.02		C		
-012	2 X 8	1.630/41.40	.700/17.78	1.020/25.91		1.400/35.56		D		
-013	2 X 10	1.830/46.48	.900/22.86	1.220/30.99		1.600/40.64				
-014	2 X 13	2.130/54.10	1.200/30.48	1.520/38.61		1.900/48.26				
-015	2 X 17	2.530/64.26	1.600/40.64	1.920/48.77		2.300/58.42				
-016	2 X 20	2.830/71.88	1.900/48.26	2.220/56.39		2.600/66.04				
-017	2 X 25	3.330/84.58	2.400/60.96	2.720/69.09		3.100/78.74				
-018	2 X 30	3.830/97.28	2.900/73.66	3.220/81.79		3.600/91.44	STD	D		
-019	2 X 5	1.330/33.78	.400/10.16	.720/18.29		1.100/27.94	LP	A		
-020	2 X 7	1.530/38.86	.600/15.24	.920/23.37		1.300/33.02		C		
-021	2 X 8	1.630/41.40	.700/17.78	1.020/25.91		1.400/35.56		D		
-022	2 X 10	1.830/46.48	.900/22.86	1.220/30.99		1.600/40.64				
-023	2 X 13	2.130/54.10	1.200/30.48	1.520/38.61		1.900/48.26				
-024	2 X 17	2.530/64.26	1.600/40.64	1.920/48.77		2.300/58.42				
-025	2 X 20	2.830/71.88	1.900/48.26	2.220/56.39		2.600/66.04				
-026	2 X 25	3.330/84.58	2.400/60.96	2.720/69.09		3.100/78.74				
-027	2 X 30	3.830/97.28	2.900/73.66	3.220/81.79		3.600/91.44	LP	D		
-028	2 X 5	1.330/33.78	.400/10.16	.720/18.29		1.100/27.94	NO	B		
-029	2 X 5	1.330/33.78	.400/10.16	.720/18.29		1.100/27.94	STD	B		
-030	2 X 5	1.330/33.78	.400/10.16	.720/18.29	.105/2.67	1.100/27.94	LP	B		
-031	2 X 5	1.330/33.78	.400/10.16	.720/18.29	.150/3.81		NO	A		
-032	2 X 7	1.530/38.86	.600/15.24	.920/23.37		1.300/33.02		C		
-033	2 X 8	1.630/41.40	.700/17.78	1.020/25.91		1.400/35.56		D		
-034	2 X 10	1.830/46.48	.900/22.86	1.220/30.99		1.600/40.64		D		
-035	2 X 13	2.130/54.10	1.200/30.48	1.520/38.61		1.900/48.26		D		
66207-036	2 X 17	2.530/64.26	1.600/40.64	1.920/48.77	.150/3.81	2.300/58.42	NO	D	RND	30µ"/0.76µ Au OR GXT OVER 50µ"/1.27µ Ni



FCIconnect.com

Copyright FCI

mat'l. code		surface ISO 1302 ✓		tolerance ISO 406 ISO 1101		projection ⊕		product family QKE. HDR.	
ltr	ecn no	dr	date	tolerances unless otherwise specified		INCH/MM		title	
P				angles	linear	.XX±.01/XX±0.3 .XXX±.005/XX±0.13 .XXXX±.0020/XXX±0.051		QUICKIE HDR, STRIGHT 3 WALL LATCH & EJECT	
				0'±2'		scale 2:1		dwg no sheet 4 of 8 size	
				dr	J. SHREINER	11/15/90		66207 A3	
				enr	M. SMIK	11/15/90		type Product Customer Drawing	
				chr	M. SMYK	11/15/90			
				appd	M. SMYK	11/15/90			
sheet index	revision sheet								

form: A3 1 2 3 4 5 6

PRODUCT NO NOTE 11	SIZE	DIM A	DIM B	DIM C	DIM D	DIM E	LATCH NOTE 7	STYLE	PIN SHAPE	PIN PLATING (NOTE 14)
66207-037	2 X 20	2.830/71.88	1.900/48.26	2.220/56.39	.150/3.81	2.600/76.04	NO	D	RND	30μ"/0.76μ Au OR GXT OVER 50μ"/1.27μ Ni
-038	2 X 25	3.330/84.58	2.400/60.96	2.720/69.09		3.100/78.74	NO	D		
-039	2 X 30	3.830/97.28	2.900/73.66	3.220/81.79		3.600/91.44	NO	D		
-040	2 X 5	1.330/33.78	.400/10.16	.720/18.29		1.100/27.94	STD	A		
-041	2 X 7	1.530/38.86	.600/15.24	.920/23.37		1.300/33.02		C		
-042	2 X 8	1.630/41.40	.700/17.78	1.020/25.91		1.400/35.56		D		
-043	2 X 10	1.830/46.48	.900/22.86	1.220/30.99		1.600/40.64				
-044	2 X 13	2.130/54.10	1.200/30.48	1.520/38.61		1.900/48.26				
-045	2 X 17	2.530/64.26	1.600/40.64	1.920/48.77		2.300/58.42				
-046	2 X 20	2.830/71.88	1.900/48.26	2.220/56.39		2.600/76.04				
-047	2 X 25	3.330/84.58	2.400/60.96	2.720/69.09		3.100/78.74				
-048	2 X 30	3.830/97.28	2.900/73.66	3.220/81.79		3.600/91.44	STD	D		
-049	2 X 5	1.330/33.78	.400/10.16	.720/18.29		1.100/27.94	LP	A		
-050	2 X 7	1.530/38.86	.600/15.24	.920/23.37		1.300/33.02		C		
-051	2 X 8	1.630/41.40	.700/17.78	1.020/25.91		1.400/35.56		D		
-052	2 X 10	1.830/46.48	.900/22.86	1.220/30.99		1.600/40.64				
-053	2 X 13	2.130/54.10	1.200/30.48	1.520/38.61		1.900/48.26				
-054	2 X 17	2.530/64.26	1.600/40.64	1.920/48.77		2.300/58.42				
-055	2 X 20	2.830/71.88	1.900/48.26	2.220/56.39		2.600/76.04				
-056	2 X 25	3.330/84.58	2.400/60.96	2.720/69.09		3.100/78.74				
-057	2 X 30	3.830/97.28	2.900/73.66	3.220/81.79		3.600/91.44	LP	D		
-058	2 X 5	1.330/33.78	.400/10.16	.720/18.29		1.100/27.94	NO	B		
-059	2 X 5	1.330/33.78	.400/10.16	.720/18.29		1.100/27.94	STD	B		
-060	2 X 5	1.330/33.78	.400/10.16	.720/18.29	.150/3.81	1.100/27.94	LP	B	RND	
-061	2 X 5	1.330/33.78	.400/10.16	.720/18.29	.675/17.15	1.100/27.94	NO	A	SQ	
-062	2 X 7	1.530/38.86	.600/15.24	.920/23.37		1.300/33.02		C		
-063	2 X 8	1.630/41.40	.700/17.78	1.020/25.91		1.400/35.56		D		
-064	2 X 10	1.830/46.48	.900/22.86	1.220/30.99		1.600/40.64				
-065	2 X 13	2.130/54.10	1.200/30.48	1.520/38.61		1.900/48.26				
-066	2 X 17	2.530/64.26	1.600/40.64	1.920/48.77		2.300/58.42				
-067	2 X 20	2.830/71.88	1.900/48.26	2.220/56.39		2.600/76.04				
-068	2 X 25	3.330/84.58	2.400/60.96	2.720/69.09		3.100/78.74				
-069	2 X 30	3.830/97.28	2.900/73.66	3.220/81.79		3.600/91.44	NO	D		
-070	2 X 5	1.330/33.78	.400/10.16	.720/18.29		1.100/27.94	STD	A		
-071	2 X 7	1.530/38.86	.600/15.24	.920/23.37		1.300/33.02	STD	C		
66207-072	2 X 8	1.630/41.40	.700/17.78	1.020/25.91	.675/17.15	1.400/35.56	STD	D	SQ	30μ"/0.76μ Au OR GXT OVER 50μ"/1.27μ Ni



FCIconnect.com

Copyright FCI

mat'l. code		surface ISO 1302 ✓		tolerance ISO 406 ISO 1101		projection ⊕		product family QKE. HDR.	
ltr		ecn no		date		tolerances unless otherwise specified		title	
P						linear		QUICKIE HDR, STRIGHT 3 WALL LATCH & EJECT	
						0°±2'		INCH/MM	
								scale 2:1	
				dr J. SHREINER 11/15/90				dwg no sheet 5 of 8 size	
				enfr M. SMIK 11/15/90				66207 A3	
				chr M. SMYK 11/15/90				type Product Customer Drawing	
				appd M. SMYK 11/15/90					
sheet index		revision sheet							



form: A3

PRODUCT NO NOTE 11	SIZE	DIM A	DIM B	DIM C	DIM D	DIM E	LATCH NOTE 7	STYLE	PIN SHAPE	PIN PLATING (NOTE 14)
66207-073	2 X 10	1.830/46.48	.900/22.86	1.220/30.99	.675/17.15	1.600/40.64	STD	D	SQ	30µ"/0.76µ Au OR GXT OVER 50µ"/1.27µ Ni
-074	2 X 13	2.130/54.10	1.200/30.48	1.520/38.61		1.900/48.26				
-075	2 X 17	2.530/64.26	1.600/40.64	1.920/48.77		2.300/58.42				
-076	2 X 20	2.830/71.88	1.900/48.26	2.220/56.39		2.600/76.04				
-077	2 X 25	3.330/84.58	2.400/60.96	2.720/69.09		3.100/78.74				
-078	2 X 30	3.830/97.28	2.900/73.66	3.220/81.79		3.600/91.44	STD	D		
-079	2 X 5	1.330/33.78	.400/10.16	.720/18.29		1.100/27.94	LP	A		
-080	2 X 7	1.530/38.86	.600/15.24	.920/23.37		1.300/33.02		C		
-081	2 X 8	1.630/41.40	.700/17.78	1.020/25.91		1.400/35.56		D		
-082	2 X 10	1.830/46.48	.900/22.86	1.220/30.99		1.600/40.64				
-083	2 X 13	2.130/54.10	1.200/30.48	1.520/38.61		1.900/48.26				
-084	2 X 17	2.530/64.26	1.600/40.64	1.920/48.77		2.300/58.42				
-085	2 X 20	2.830/71.88	1.900/48.26	2.220/56.39		2.600/76.04				
-086	2 X 25	3.330/84.58	2.400/60.96	2.720/69.09		3.100/78.74				
-087	2 X 30	3.830/97.28	2.900/73.66	3.220/81.79		3.600/91.44	LP	D		
-088	2 X 5	1.330/33.78	.400/10.16	.720/18.29		1.100/27.94	NO	B		
-089	2 X 5	1.330/33.78	.400/10.16	.720/18.29		1.100/27.94	STD	B		
-090	2 X 5	1.330/33.78	.400/10.16	.720/18.29	.675/17.15	1.100/27.94	LP	B	SQ	
-091	2 X 12	2.030/45.56	1.100/27.94	1.420/36.07	.105/2.67	1.800/45.72	NO	D	RND	
-092					.105/2.67		STD			
-093					.105/2.67		LP			
-094					.150/3.81		NO			
-095					.150/3.81		STD			
-096					.150/3.81		LP		RND	
-097					.675/17.15		NO		SQ	
-098					.675/17.15		STD		SQ	
-099	2 X 12	2.030/45.56	1.100/27.94	1.420/36.07	.675/17.15	1.800/45.72	LP		SQ	
-100	2 X 15	2.330/59.18	1.400/35.56	1.720/43.69	.105/2.67	2.100/53.34	NO		RND	
-101					.105/2.67		STD			
-102					.105/2.67		LP			
-103					.150/3.81		NO			
-104					.150/3.81		STD			
-105					.150/3.81		LP		RND	
-106					.675/17.15		NO		SQ	
-107					.675/17.15		STD		SQ	
66207-108	2 X 15	2.330/59.18	1.400/35.56	1.720/43.69	.675/17.15	2.100/53.34	LP	D	SQ	30µ"/0.76µ Au OR GXT OVER 50µ"/1.27µ Ni



FCIconnect.com

Copyright FCI

mat'l. code		surface ISO 1302 ✓		tolerance ISO 406 ISO 1101		projection ⊕		product family QKE. HDR.	
ltr	ecn no	dr	date	tolerances unless otherwise specified		INCH/MM		title	
P				angles	linear	.XX±.01/XX±0.3 .XXX±.005/XX±0.13 .XXXX±.0020/XXX±0.051		QUICKIE HDR, STRIGHT 3 WALL LATCH & EJECT	
				0°±2'		scale 2:1		dwg no sheet 6 of 8 size	
				dr	J. SHREINER	11/15/90		66207 A3	
				enr	M. SMIK	11/15/90		type Product Customer Drawing	
				chr	M. SMYK	11/15/90			
				appd	M. SMYK	11/15/90			
sheet index	revision sheet								

PRODUCT NO NOTE 11	SIZE	DIM A	DIM B	DIM C	DIM D	DIM E	LATCH	STYLE	PIN SHAPE	PIN PLATING (NOTE 14)	PIN OMIT
66207-109	2 X 22	3.030/76.96	2.100/53.34	2.420/61.47	.105/2.67	2.800/81.12	NO	D	RND	30μ"/0.76μ Au OR GXT OVER 50μ"/1.27μ Ni	
-110					.105/2.67		STD				
-111					.105/2.67		LP				
-112					.150/3.81		NO				
-113					.150/3.81		STD				
-114					.150/3.81		LP		RND		
-115					.675/17.15		NO		SQ		
-116					.675/17.15		STD		SQ		
-117	2 X 22	3.030/76.96	2.100/53.34	2.420/61.47	.675/17.15	2.800/81.12	LP		SQ	30μ"/0.76μ Au OR GXT OVER 50μ"/1.27μ Ni	
-118	2 X 17	2.530/64.26	1.600/40.64	1.920/48.77	.150/3.81	2.300/58.42	LP		RND	15μ"/0.38μ Au OR GXT OVER 50μ"/1.27μ Ni	
-119	2 X 17	2.530/64.26	1.600/40.64	1.920/48.77	.150/3.81	2.300/58.42	NO		RND	15μ"/0.38μ Au OR GXT OVER 50μ"/1.27μ Ni	
-120	2 X 10	1.830/46.48	.900/22.86	1.220/30.99	.105/2.67	1.600/40.64	NOTE 9		SQ	30μ"/0.76μ Au OR GXT OVER 50μ"/1.27μ Ni	
-121	2 X 10	1.830/46.48	.900/22.86	1.220/30.99	.150/3.81	1.600/40.64	NOTE 9	D	RND		
-122	2 X 5	1.330/33.78	.400/10.16	.720/18.29	.105/2.67	1.100/27.94	NOTE 9	B	SQ		
-123	2 X 5	1.330/33.78	.400/10.16	.720/18.29		1.100/27.94	NO	B			
-124	2 X 10	1.830/46.48	.900/22.86	1.220/30.99		1.600/40.64	NO	D			
-125	2 X 25	3.330/84.58	2.400/60.96	2.720/69.09		3.100/78.74	NOTE 9	D			
-126	2 X 25	3.330/84.58	2.400/60.96	2.720/69.09		3.100/78.74	NO	D			
-127	2 X 5	1.330/33.78	.400/10.16	.720/18.29		1.100/27.94	NO	A			
-128	2 X 5	1.330/33.78	.400/10.16	.720/18.29		1.100/27.94	NOTE 9	A			
-129	2 X 7	1.530/38.86	.600/15.24	.920/23.37		1.300/33.02	NO	C			
-130	2 X 7	1.530/38.86	.600/15.24	.920/23.37		1.300/33.02	NOTE 9	C			
-131	2 X 8	1.630/41.40	.700/17.78	1.020/25.91		1.400/35.56	NO	D			
-132	2 X 8	1.630/41.40	.700/17.78	1.020/25.91		1.400/35.56	NOTE 9				
-133	2 X 13	2.130/54.10	1.200/30.48	1.520/38.61		1.900/48.26	NO				
-134	2 X 13	2.130/54.10	1.200/30.48	1.520/38.61		1.900/48.26	NOTE 9				
-135	2 X 17	2.530/64.26	1.600/40.64	1.920/48.77		2.300/58.42	NO				
-136	2 X 17	2.530/64.26	1.600/40.64	1.920/48.77		2.300/58.42	NOTE 9				
-137	2 X 20	2.830/71.88	1.900/48.26	2.220/56.39		2.600/66.04	NO				
-138	2 X 20	2.830/71.88	1.900/48.26	2.220/56.39		2.600/66.04	NOTE 9				
-139	2 X 30	3.830/97.28	2.900/73.66	3.220/81.79		3.600/91.44	NO				
-140	2 X 30	3.830/97.28	2.900/73.66	3.220/81.79		3.600/91.44	NOTE 9	D	SQ	30μ"/0.76μ Au OR GXT OVER 50μ"/1.27μ Ni	
-141	2 X 5	1.330/33.78	.400/10.16	.720/18.29	.105/2.67	1.100/27.94	LP	A	RND	15μ"/0.38μ Au OR GXT OVER 50μ"/1.27μ Ni	10
-142	2 X 5	1.330/33.78	.400/10.16	.720/18.29	.120/27.94	1.100/27.94	LP	A	RND	15μ"/0.38μ Au OR GXT OVER 50μ"/1.27μ Ni	10
-143	2 X 5	1.330/33.78	.400/10.16	.720/18.29	.105/2.67	1.100/27.94	NO	A	RND	15μ"/0.38μ Au OR GXT OVER 50μ"/1.27μ Ni	10
66207-144	2 X 5	1.330/33.78	.400/10.16	.720/18.29	.120/27.94	1.100/27.94	NO	A	RND	15μ"/0.38μ Au OR GXT OVER 50μ"/1.27μ Ni	10



FCIconnect.com

Copyright FCI

mat'l. code		surface ISO 1302 ✓		tolerance ISO 406 ISO 1101		projection ⊕		product family QKE. HDR.	
ltr	ecn	no	dr	date		tolerances unless otherwise specified		title	
P						angles	linear	QUICKIE HDR, STRIGHT 3 WALL LATCH & EJECT	
						0°±2'	XXXX±.01/XX±0.3 XXXX±.005/XX±0.13 XXXX±.0020/XXX±0.051	INCH/MM	
								scale 2:1	
						dr	J. SHREINER	11/15/90	dwg no
						enfr	M. SMIK	11/15/90	sheet 7 of 8 size
						chr	M. SMYK	11/15/90	66207
						appd	M. SMYK	11/15/90	A3
sheet index		revision sheet						type Product Customer Drawing	



PRODUCT NO NOTE 11	SIZE	DIM A	DIM B	DIM C	DIM D	DIM E	LATCH	STYLE	PIN SHAPE	PIN PLATING (NOTE 14)	PIN OMIT
66207-145	2 X 5	1.330/33.78	.400/10.16	.720/18.29	.120/27.94	1.100/27.94	NOTE 9	A	RND	15μ"/0.38μ Au OR GXT OVER 50μ"/1.27μ Ni	10
66207-146	2 X 30	3.830/97.28	2.900/73.66	3.220/81.79	.150/3.81	3.600/91.44	NOTE 9	D	RND	30μ"/0.76μ Au OR GXT OVER 50μ"/1.27μ Ni	-



Copyright FCI

mat'l. code		surface ISO 1302 <input checked="" type="checkbox"/>		tolerance ISO 406 ISO 1101		projection 		product family QKE. HDR.			
ltr	ecn	no	dr	date		tolerances unless otherwise specified		title		sheet 8 of 8 size	
P						angles	linear	INCH/MM		QUICKIE HDR, STRIGHT 3 WALL LATCH & EJECT	
						0°±2'		scale 2:1		dwg no 66207 A3	
						dr	J. SHREINER	11/15/90		type Product Customer Drawing	
						enfr	M. SMIK	11/15/90			
						chr	M. SMYK	11/15/90			
						appd	M. SMYK	11/15/90			
sheet index	revision sheet										

form: A3 1 2 3 4 5 6