

THIS DRAWING IS UNPUBLISHED. RELEASED FOR PUBLICATION  
 © COPYRIGHT BY TYCO ELECTRONICS CORPORATION. ALL INTERNATIONAL RIGHTS RESERVED.

LOC	DIST	REVISIONS			
P	LTR	DESCRIPTION	DATE	DWN	APVD
G	14	H	REV PER ECR 10-000722	25JAN10	JR TM

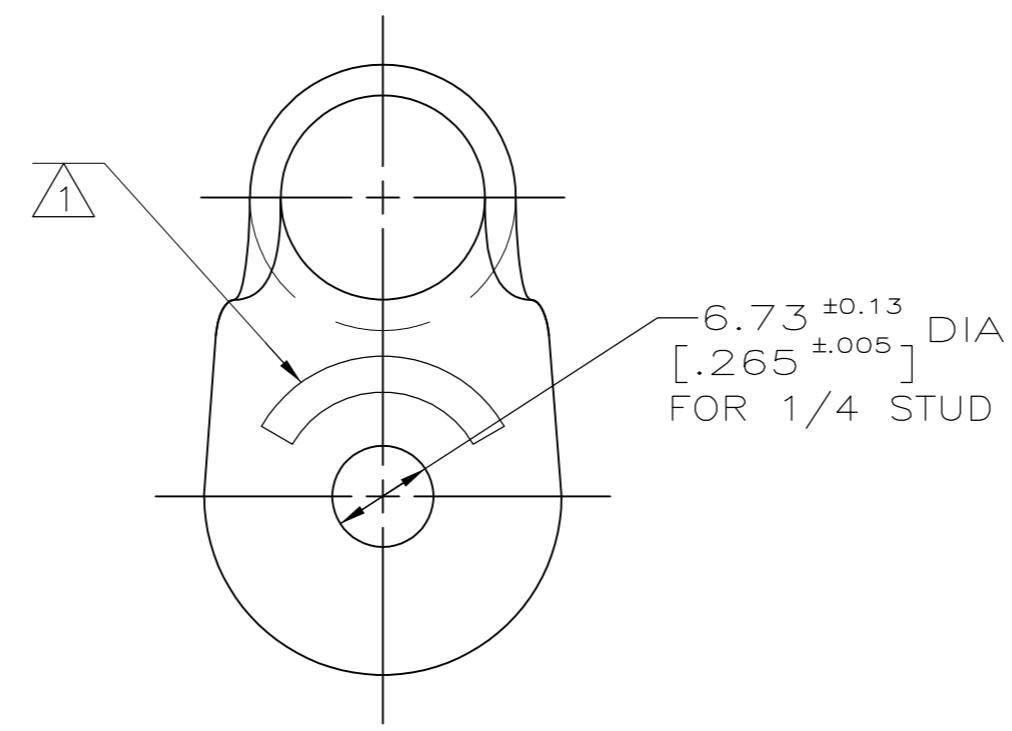
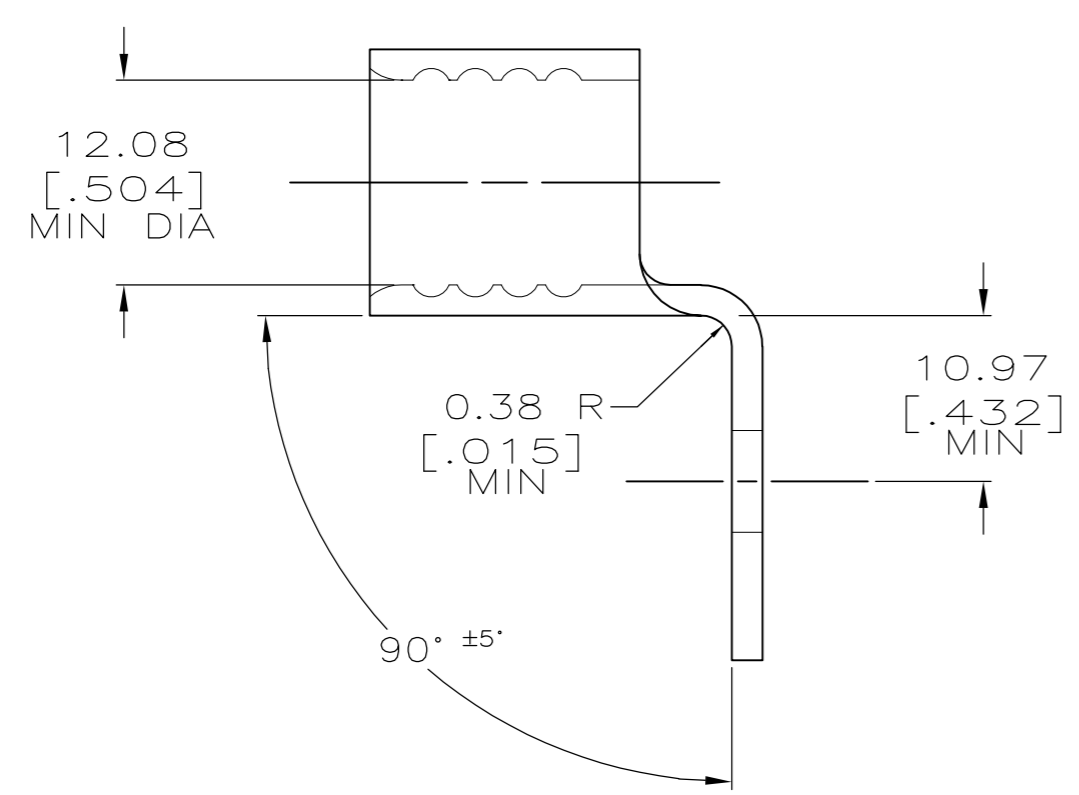
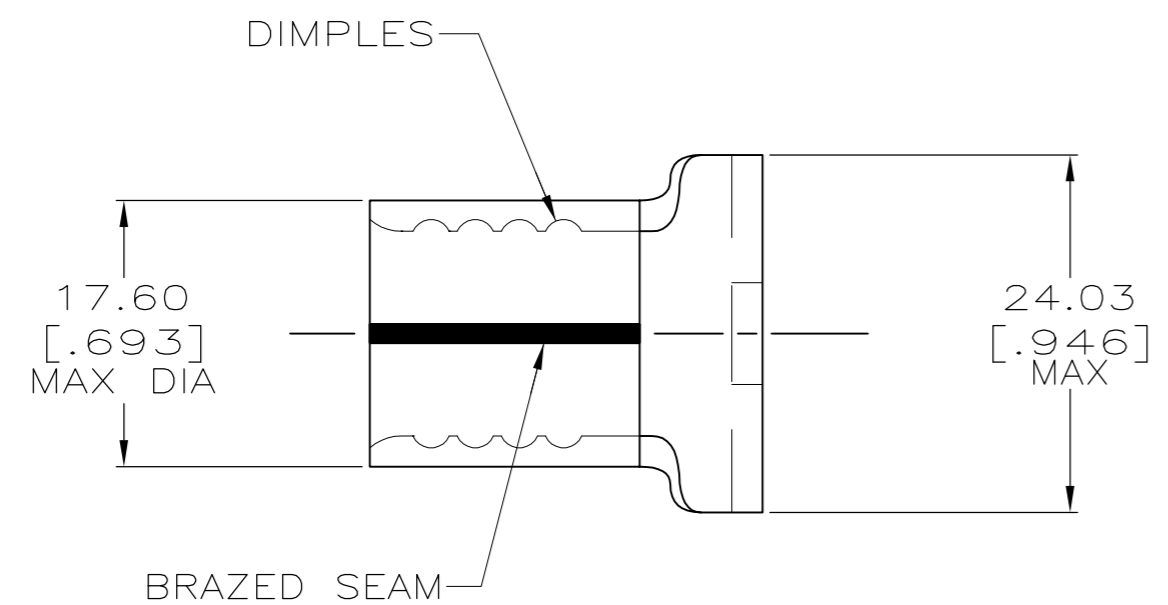

<b>AMP</b> WIRE RANGE	E13288 Listed	LR7189 Certified
2/0 AWG SOLID OR STRANDED	2/0 AWG STRANDED	2/0 AWG SOLID OR STRANDED

- 1 STAMP AMP 2/0W\* APPROX AS SHOWN
- 2 COPPER PER ASTM B-152, ANNEALED
- 3 TIN PLATE 0.00254 [.000100] MIN THK EXT. PER ASTM B-545
- 4 MAX RECOMMENDED OPERATING TEMP IS 170°C.
- 5 WIRE CROSS SECTIONAL AREA RANGE: 60.6-76.3mm [119,500-150,500] CMA SOLID OR STRANDED.

50	LOOSE PIECE	324028
QTY	PACKAGING TYPE	PART NO.

THIS DRAWING IS A CONTROLLED DOCUMENT.		DWN DK SCHRUM 1/14/94	Tyco Electronics Corporation Harrisburg, PA 17105-3608	
DIMENSIONS: MM [INCHES]		CHK AJ KAUFMAN 1/19/94		
TOLERANCES UNLESS OTHERWISE SPECIFIED:		APVD JL MECKLEY 1/19/94		
0 PLC ± - 1 PLC ± - 2 PLC ± 0.20[.008] 3 PLC ± - 4 PLC ± - ANGLES ± -		PRODUCT SPEC -		
MATERIAL	FINISH	WEIGHT -	APPLICATION SPEC -	RESTRICTED TO -
			NAME	TERMINAL, RING TONGUE, BENT 90
			SIZE	A2
			CAGE CODE	00779
			DRAWING NO	C=324028
			SCALE	2:1
			SHEET	1 of 1
			REV	H
CUSTOMER DRAWING				

324028