

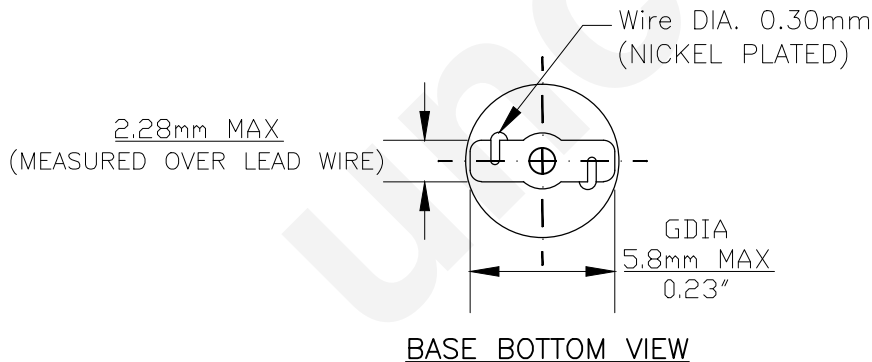

PART NO.	BASE TYPE	DESIGN VOLTS	DESIGN AMPS	MSCD	FILAMENT TYPE	AVERAGE LIFE HOURS	REVISIONS			
							REV #	DESCRIPTION	DATE	APPROVED
73R	Sub-miniature Glass Wedge (T-1 3/4)	14.0V	0.08±15%	0.3±30%	C-2F	15,000	1	ISSUED	06/05/2014	R.M.

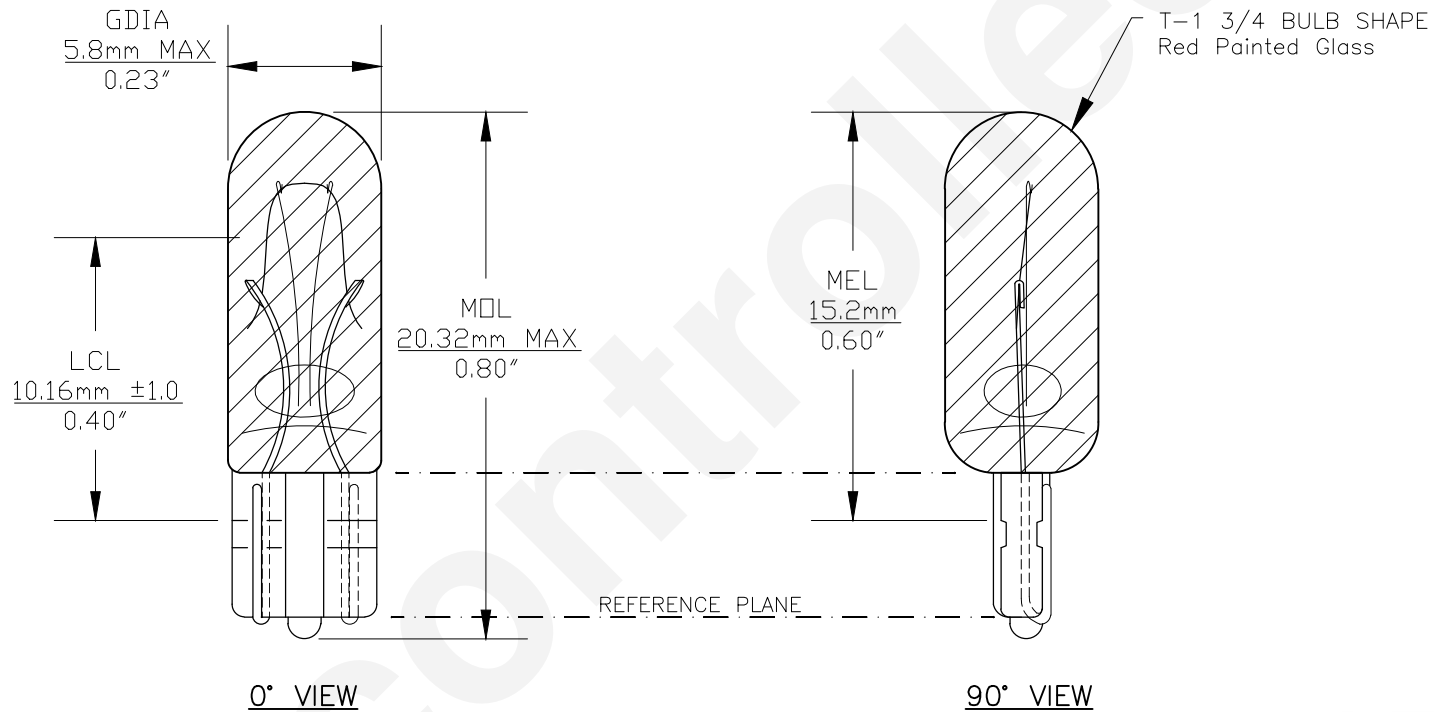

Note: Made according to SAE specifications



UNLESS OTHERWISE SPECIFIED: DIMENSIONS ARE IN INCHES TOLERANCES		CEC INDUSTRIES LTD			
DECIMALS	ANGULAR	599 BOND STREET		LINCOLNSHIRE, IL 60069	
.XX ± .05	± 0.5°	TITLE LIGHT BULB NO. 73R			
.XXX ± .010		SIZE A	FSCM NO.	DWG NO. 73R	REV 1
FRACTIONAL	± 1/64	CHECKED	SCALE	PLOT SCALE	SHEET 1 OF 1
DRAWN ROSE MEDINA	DATE 06/05/2014	MATERIAL			
FILE 73R.pdf		DRAWING NOT TO SCALE			