

REVISIONS			
LTR	DESCRIPTION	DATE	APPROVED
C	REVISED PER ECN T-19793	1-16-95	R.H.

NOTES:

1. SCREWS ARE SHIPPED LOOSE.
2. MATERIAL: BACKSHELL – ALUMINUM ALLOY, CADMIUM PLATED
BRAID – COPPER ALLOY, TIN PLATED
SCREW – STAINLESS STEEL, PASSIVATED & CAD PLATED
W/THREAD LOCK.

△ THE 12.0" APPROX. APPLIES TO THE BRAID IN THE "FLAT" AS SUPPLIED CONDITION.

4. SHIELDING EFFECTIVENESS IS LEVEL 1 PER C-6111 AND C-6115.

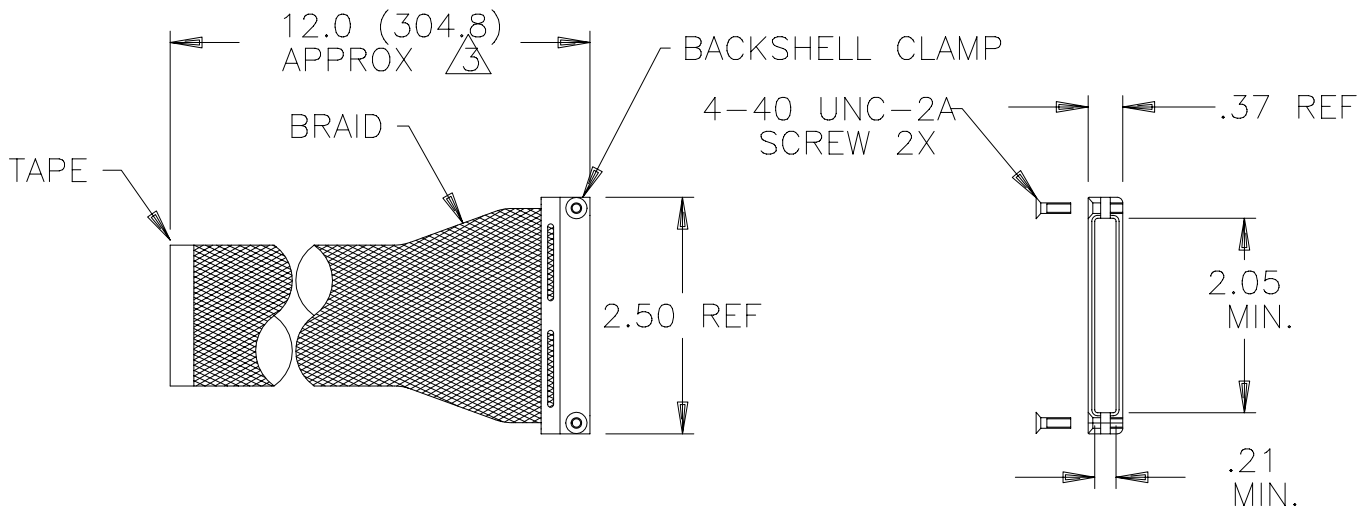

If this document is printed it becomes uncontrolled.
Check with the web for latest revision.

SPECIFICATION CONTROL DRAWING

© Raychem Corporation 1993

UNLESS OTHERWISE SPECIFIED DIMENSIONS ARE IN INCHES. METRIC DIMENSIONS ARE IN BRACKETS.	DRAWN D.PIQUE'	DATE 93MAR22	Raychem			RAYCHEM CORPORATION 300 CONSTITUTION DRIVE MENLO PARK, CALIFORNIA 94025
	CHECKED M. PIOZET	DATE 93OCT01	TITLE			
TOLERANCES: .XXX ± [mm] .XX ±.03 [mm] ANGLE	APPROVED P.DUTTON	DATE 93OCT01	BACKSHELL, 2 INCH EMX SUPPRESSING MTC SERIES			
	THIRD ANGLE PROJECTION					
	CAD NAME 001725-1.DWG	SIZE A	CODE IDENT. NO. 06090	DWG. NO. CHA-0275	REV C	
	P.C.N. 129029	SCALE: NONE		DO NOT SCALE THIS DRAWING	SHEET 1 OF 1	