

THIS DRAWING IS UNPUBLISHED. RELEASED FOR PUBLICATION  
 © COPYRIGHT BY TYCO ELECTRONICS CORPORATION. ALL RIGHTS RESERVED.

LOC	DIST	REVISIONS			
P	LTR	DESCRIPTION	DATE	DWN	APVD
AF	50	B1	REVISED PER ECR-18-009392	29MAR2019	BDA SV

- 1 CONTINUOUS STRIP ON REELS WITH TERMINALS LOCATED ON 8.38±0.08 [.330±.003] CENTERS.
- 2 SLOT TERMINATES A SINGLE OR DOUBLE MAGNET WIRE OF THE SAME SIZE AND TYPE.  
 COPPER RANGE: 0.36-0.57mm [#27-#23] AWG.  
 ALUMINIUM RANGE: 0.51-0.64mm [#24-#22] AWG  
 ALUMINIUM WIRE RANGE APPLIES TO POST TIN PLATED PART NOS ONLY

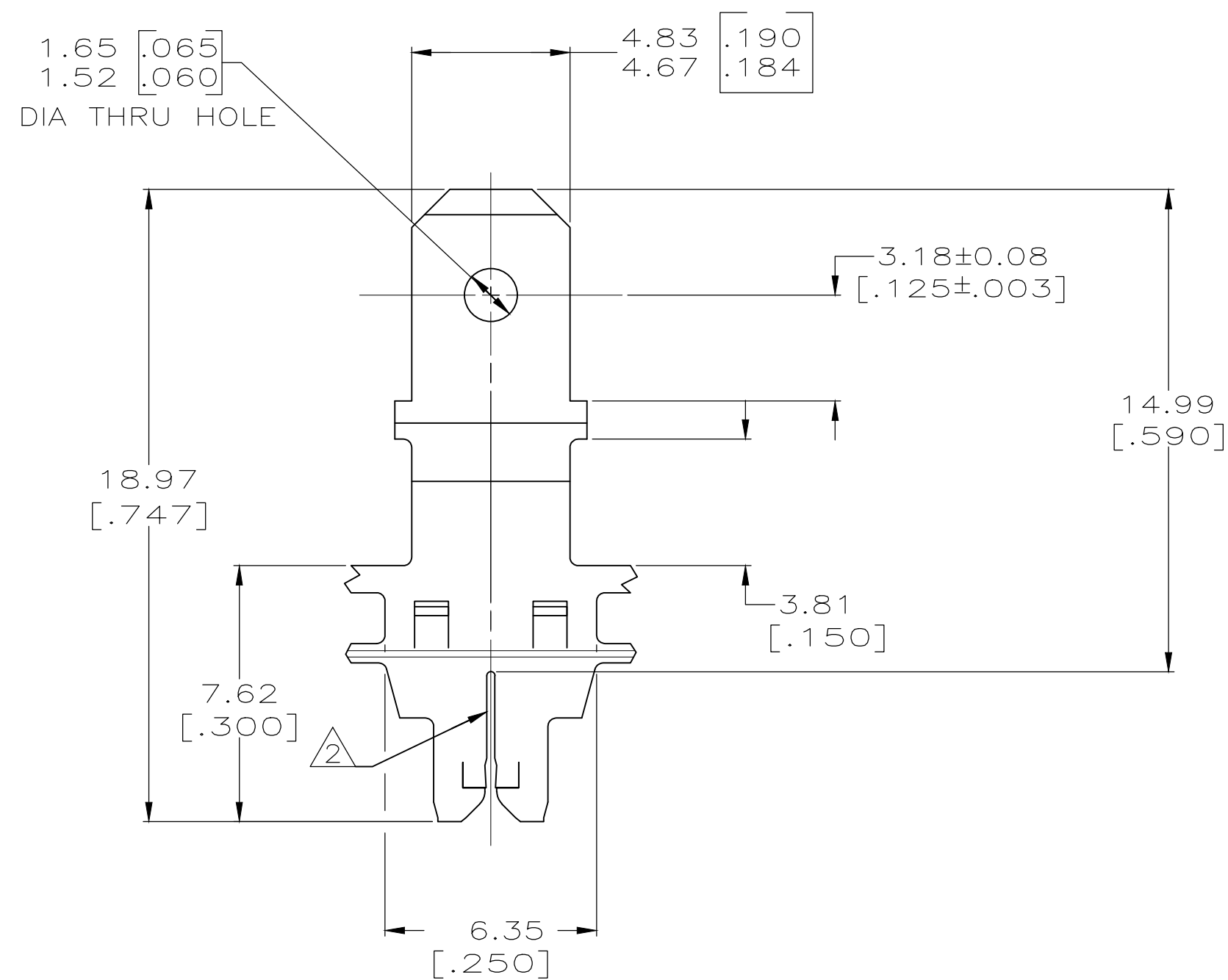
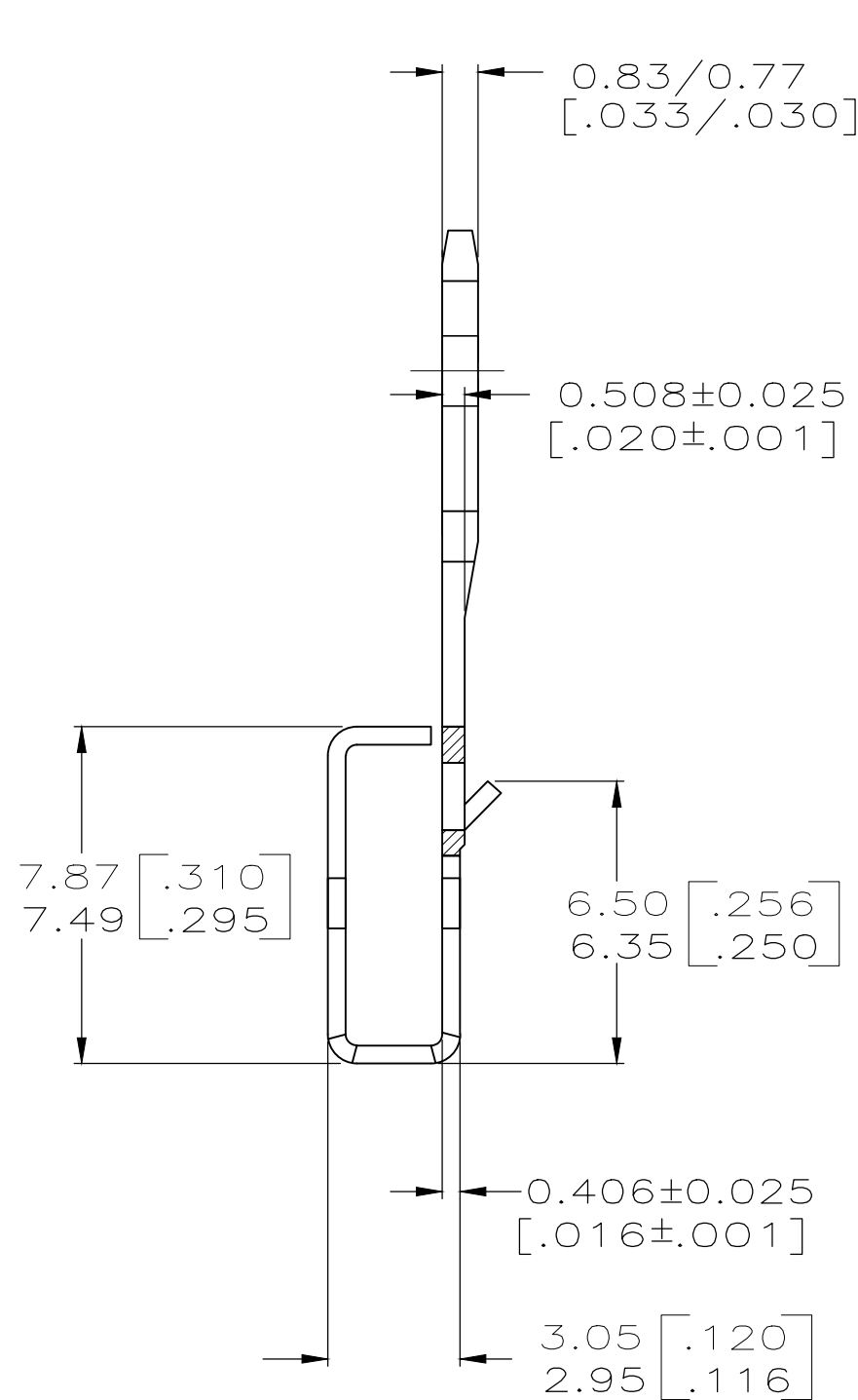
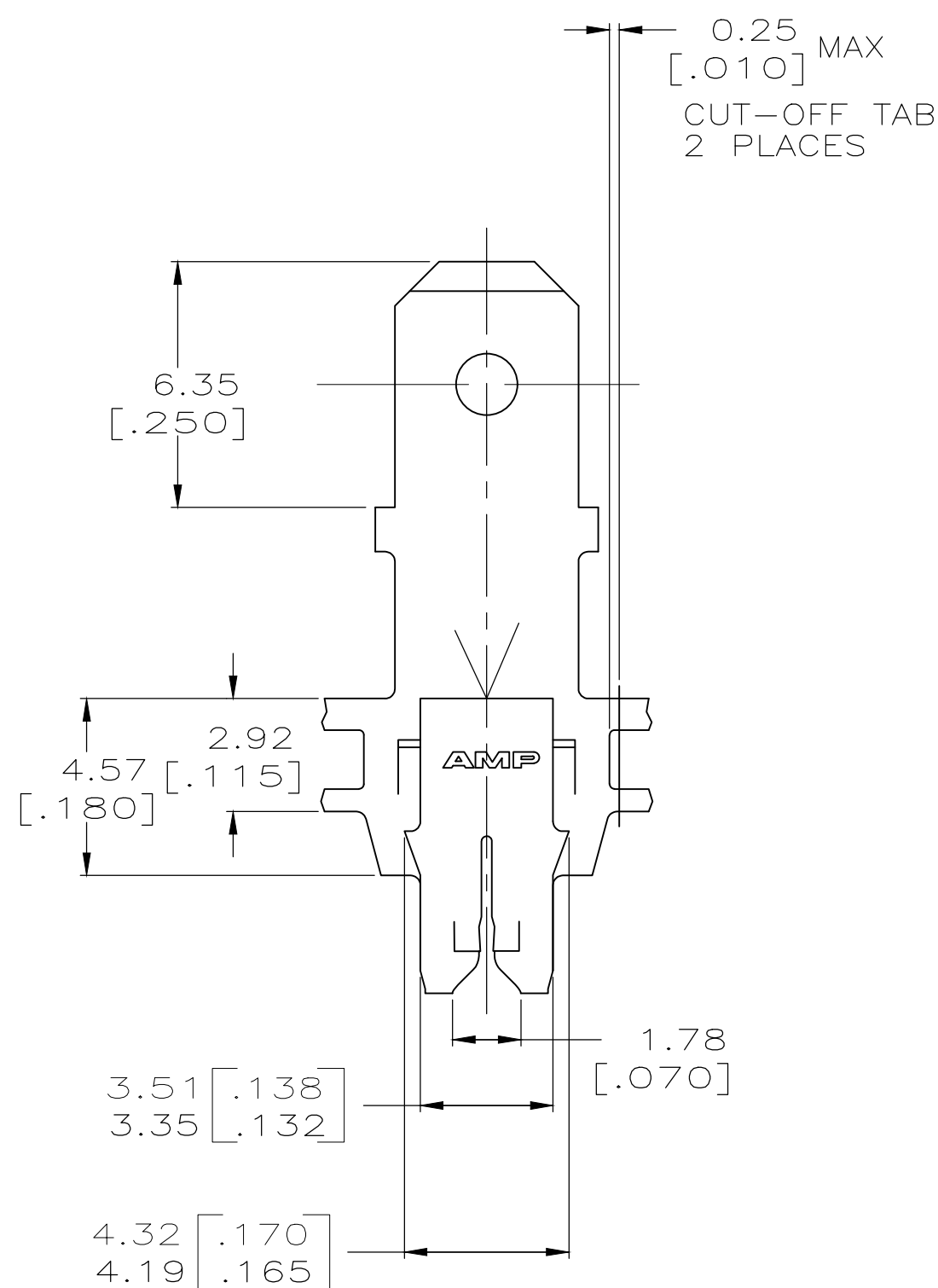
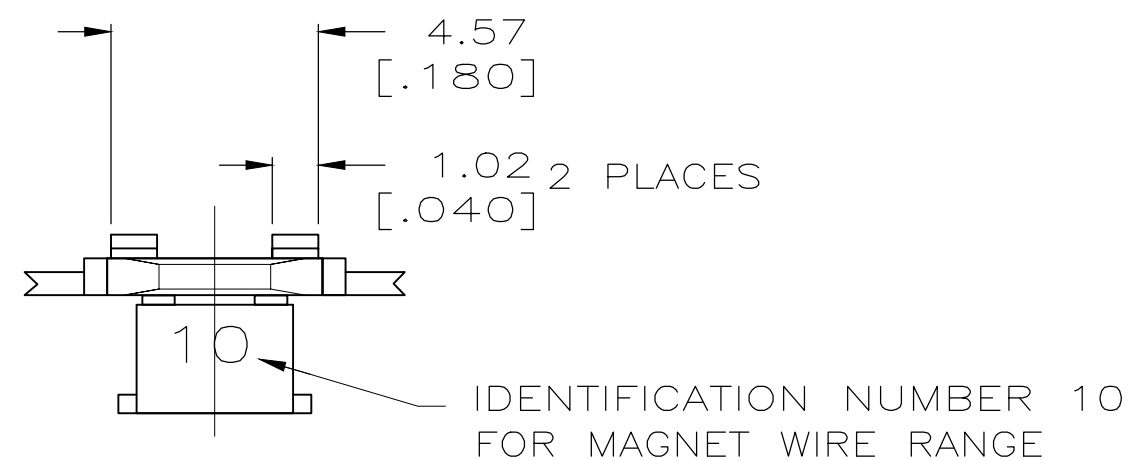

1217993-1  
 PART NUMBER

THIS DRAWING IS A CONTROLLED DOCUMENT.		DWN 02OCT2003 MICHAEL S. FEHER	Tyco Electronics Corporation Harrisburg, PA 17105-3608	
DIMENSIONS: mm [ INCHES ]		CHK 02OCT2003 KURT A. RANDOLPH		
TOLERANCES UNLESS OTHERWISE SPECIFIED:		APVD 02OCT2003 KURT A. RANDOLPH	NAME TAB, 4.75 [.187] FASTON,™ 300 SERIES MAG-MATE™	
0 PLC ± - 1 PLC ± - 2 PLC ± 0.25 [.010] 3 PLC ± - 4 PLC ± - ANGLES ± -		PRODUCT SPEC 108-2012	SIZE A2	CAGE CODE 00779
MATERIAL 4M PRE-MILLED BRASS		FINISH 0.002032 [.000080] MIN TIN PLATE	WEIGHT -	DRAWING NO 114-2094
CUSTOMER DRAWING			SCALE 6:1	SHEET 1 OF 1
			RESTRICTED TO -	REV B1