

NOTES:
 1-Material: Phosphor bronze, thickness 0.20
 socket : Phosphor bronze
 2-Finish on contact area:
 - gold over nickel see table
 finish on termination: bright tin lead over nickel
 3-Wire range: 20 to 28 AWG
 4-Max outer dia of wire insulator:
 -1.73 mm for contact #20-24
 -1.02 mm for contact #24-28
 5-Current carrying capacity per contact:
 5.Amps max when crimped to #20 AWG
 5 Amps max when crimped to #22 AWG
 3 Amps max when crimped to #24 AWG
 2 Amps max when crimped to #26 AWG
 1 Amps max when crimped to #28 AWG
 6-After 5 insertions into connector,
 contact retention must be 5 pounds axial load min
 7-When contact is crimped to 20 AWG, the insulation
 support crimped height must be 1.78 mm max to ensure
 a proper insertion into housing
 6-Packaging: Reel

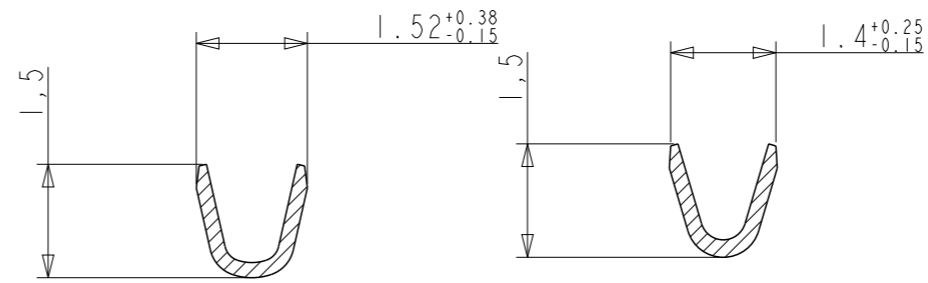

CROSS SECTIONS FOR CT #24-28

CORE RANGE	
86563003065LF	0.76µ Au/GXT
86563003065	0.76µ Au/GXT
86563003064LF	flash Au
86563003064	flash Au
PART NUMBER	Plating

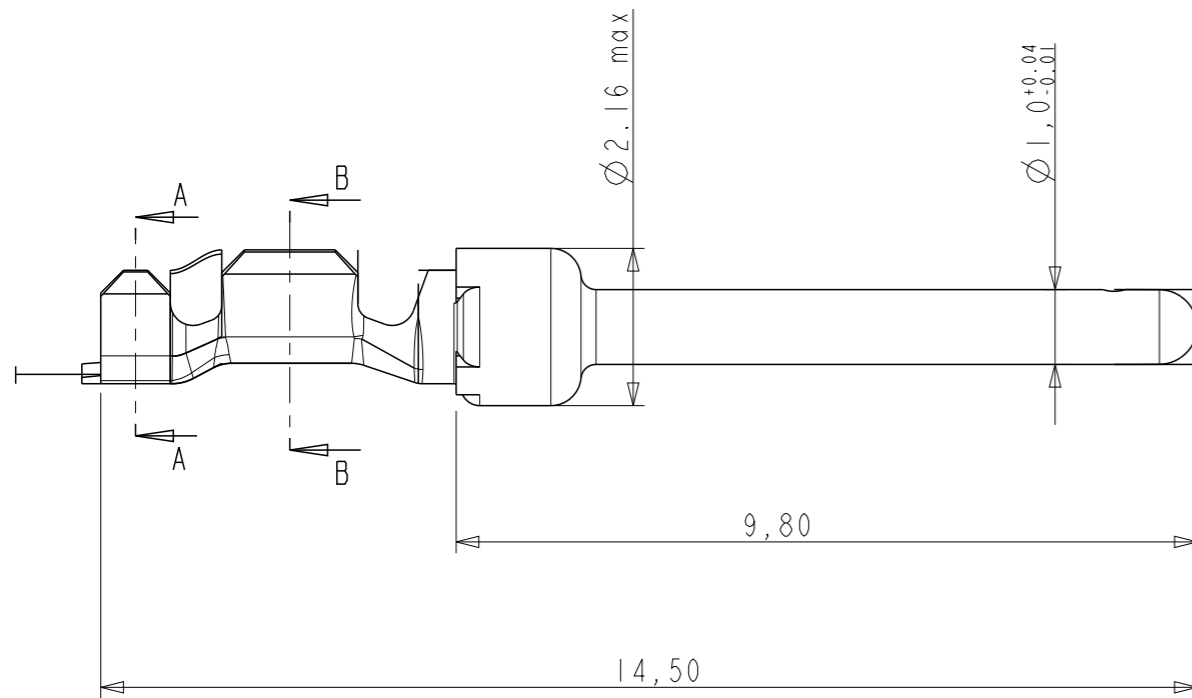
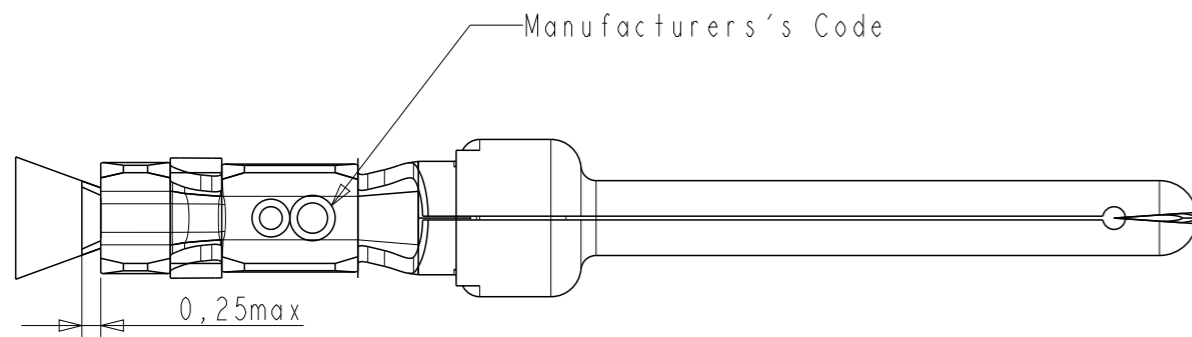

Copyright FCI.

NOTE : ROHS INFORMATIONS
 The LF products meet European union directives and other country regulations as described in GS-22-008
 Terminations plating spec : 2um Nickel min + 2um Sn min
 Packaging Spec : see GS-14-920

rev	ecn no	dr	date
D	LS06-196	MPE	27/11/2006
E	LS08-0127	MPE	13/05/2008
F	111-0003	AMR	2011-01-06
-	-	-	-
-	-	-	-
-	-	-	-
-	-	-	-

www.fciconnect.com		surface - ✓ ISO 1302	tolerance std ISO 406 ISO 1101	projection mm
TOLERANCES UNLESS OTHERWISE SPECIFIED				
Dr -	18/04/03	ANGULAR	0.X ±0.3	size A3
Eng -	-	LINEAR	0.XX ±0.1	Scale 5/1
Chr -	-	0° ±2°	0.XXX ±0.05	ECN 111-0003
Appr -	-	Product family	-	Spec ref -
FCI		Title CRIMP PIN		Rev. F
		#Wire 24-28 Ø1.02		
catalog no		-		sheet 1 of 1