

- 1 0.00076 [.000030] GOLD IN LOCALIZED PLATE AREA
0.00381 [.000150] TIN-LEAD ON SOLDER LEADS
ALL OVER 0.00127 [.000050] NICKEL
- 2 USE 1.32±0.02 [.0520±.0010] DRILLED HOLE (#55 DRILL)
FINISH TO BE TIN-LEAD OVER 0.02 [.001] MIN COPPER
- 3 PLATING: 0.0038 [.000150] TIN-LEAD OVER 0.00127 [.000050] NICKEL
- 4 SERRATIONS OPTIONAL THIS SURFACE.
- 6 PLATING: 0.0038 (.00015) TIN OVER .00127 (.000050) NICKEL.
- 7 USE 1.32+/-0.02 (.052+/-0.010) DRILLED HOLE (#55 DRILL)
FINISH TO BE TIN OVER 0.02 (.001) MIN COPPER

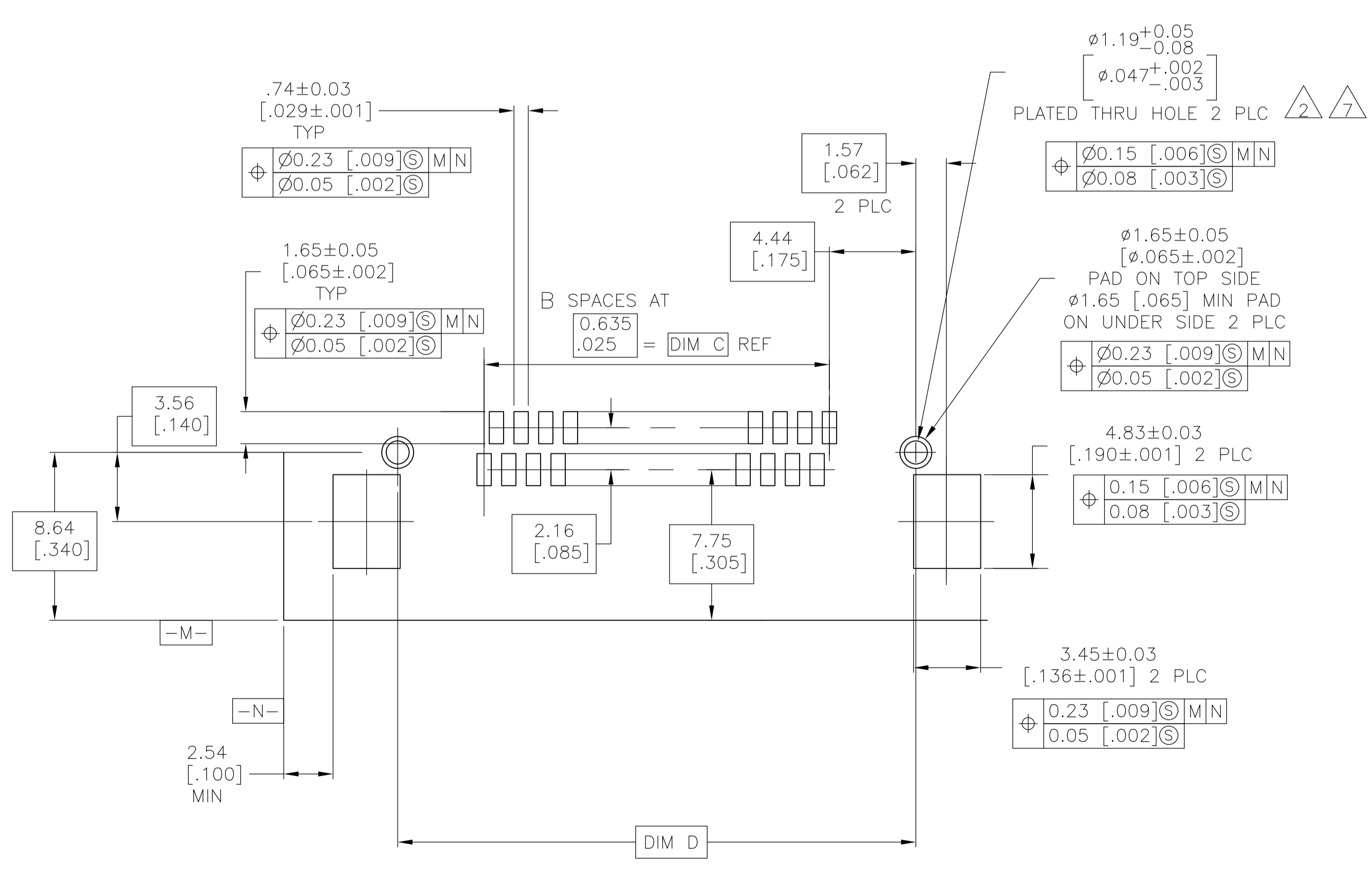

RECOMMENDED BOARD LAYOUT
SCALE 5:1

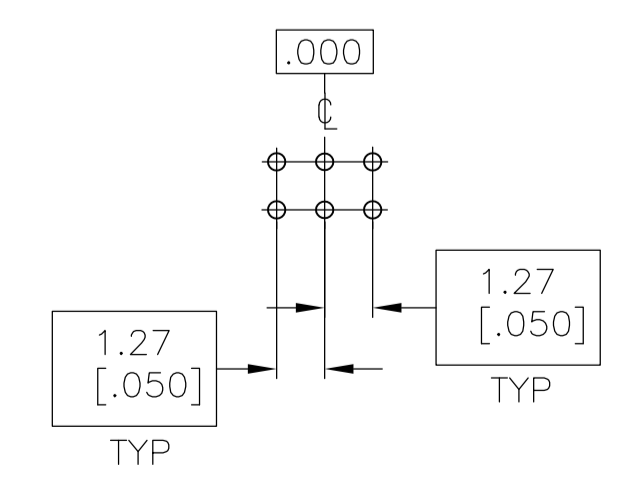

BASIC DIMENSIONS FOR EVEN NO OF SPACES (SEE TABLE)
DETAIL R

FINISH	NO. OF SPA (SEE DETAIL R)	D	C	B	A	NUMBER OF POSITIONS	PART NUMBER
1 3	14	26.67 [1.050]	18.42 [.725]	29	28.70 [1.130]	30	1977276-2
1 3	4	13.97 [.550]	5.72 [.225]	9	16.00 [.630]	10	1977276-1

THIS DRAWING IS A CONTROLLED DOCUMENT.		DIN M. BINNER 13NOV07	Tyco Electronics Corporation Harrisburg, PA 17105-3608	
DIMENSIONS: mm [INCHES]	TOLERANCES UNLESS OTHERWISE SPECIFIED:	CHK N. EPPLEY 13NOV07	NAME N. EPPLEY 13NOV07	APVD N. EPPLEY 13NOV07
0 PLC ± -	1 PLC ± -	PRODUCT SPEC 108-1332	APPLICATION SPEC 114-7010	SIZE A1
2 PLC ± ± 0.13[.005]	3 PLC ± ± -	WEIGHT -	DRAWING NO. 1977276	RESTRICTED TO -
4 PLC ± ± -	ANGLES ± ± -	MATERIAL: LCP, COLOR BLACK CONTACT, BRASS HOLDDOWN, COPPER ALLOY	CUSTOMER DRAWING	SCALE 5:1 SHEET 1 OF 1 REV A2