

TGHE Series

100W Heatsinkable Resistor

This thick-film resistor is suited for lower power applications and comes in a molded package. Suitable for variable speed drives, power supply, control equipment, communication, automatic control, engine control, etc.

FEATURES

- Thermally efficient design uses ceramic base plate for better dissipation
- Non-Inductive design
- ROHS compliant
- Materials in accordance with UL 94 V-0



CHARACTERISTICS

Resistance value range	0.24Ω to 1MΩ
Tolerance range	±1% to ±10%
TCR	≥1Ω: ±150ppm/°C <1Ω: ±250ppm/°C (+25°C to +105°C, ref. to +25°C, others on request)
Rated power	100W at +85°C bottom case temp.
Derating	0.45 K/W
Max. operating voltage	1000V DC
Dielectric strength	3000V DC
Working temperature	-55°C to +130°C
Base plate installation	M3 screw, max. torque 0.7Nm
Weight	6 grams

Derating

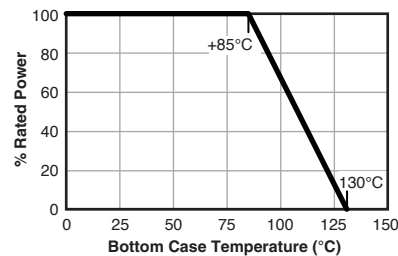

A thermal interface material with a specific thermal resistance >3.4W / (mK) and a printed thickness of <0.15mm shall be pre-applied on the resistor.

Suggested Mounting Procedure

- 1.) Position component and press down by hand
- 2.) Fix both mounting screws (M3) with 0.1 to 0.2 Nm torque
- 3.) Apply final torque to mounting screws of 0.6 to 0.7 Nm

DIMENSIONS

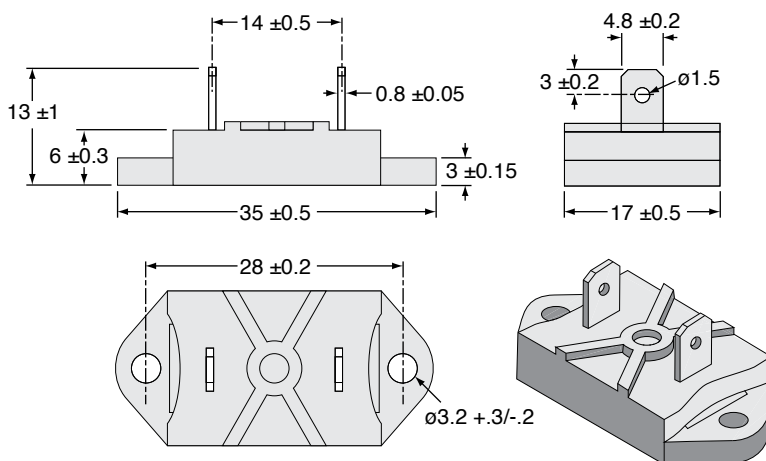

THIS PRODUCT IS DESIGNED FOR USE WITH PROPER HEATSINKING.

Maximum base plate temperature of the resistor must be monitored and kept within specified limits to establish the power rating. Best technique is to attach a thermocouple to the side of the base plate of the resistor. Temperature of plastic housing or heat sink cannot be used to establish rating of the resistor.

HOW TO ORDER

RoHS Compliant

T G H E V 1 0 0 R J E

Series	Termination	Ohm Value	Tolerance
100 watts	V = Quick Connect		J = 5% std.