

PART NUMBER	ITEM 1 BODY	ITEM 2 INSULATOR	ITEM 3 CONTACT
127-1701-221	BERYLLIUM COPPER GOLD PL .00003 MIN OVER NICKEL PL .00005 MIN OVER COPPER	TEFLON	BERYLLIUM COPPER GOLD PL .00003 MIN OVER NICKEL PL .00005 MIN OVER COPPER

REV	ECO	DATE
1	INITIAL RELEASE	12/05/2019

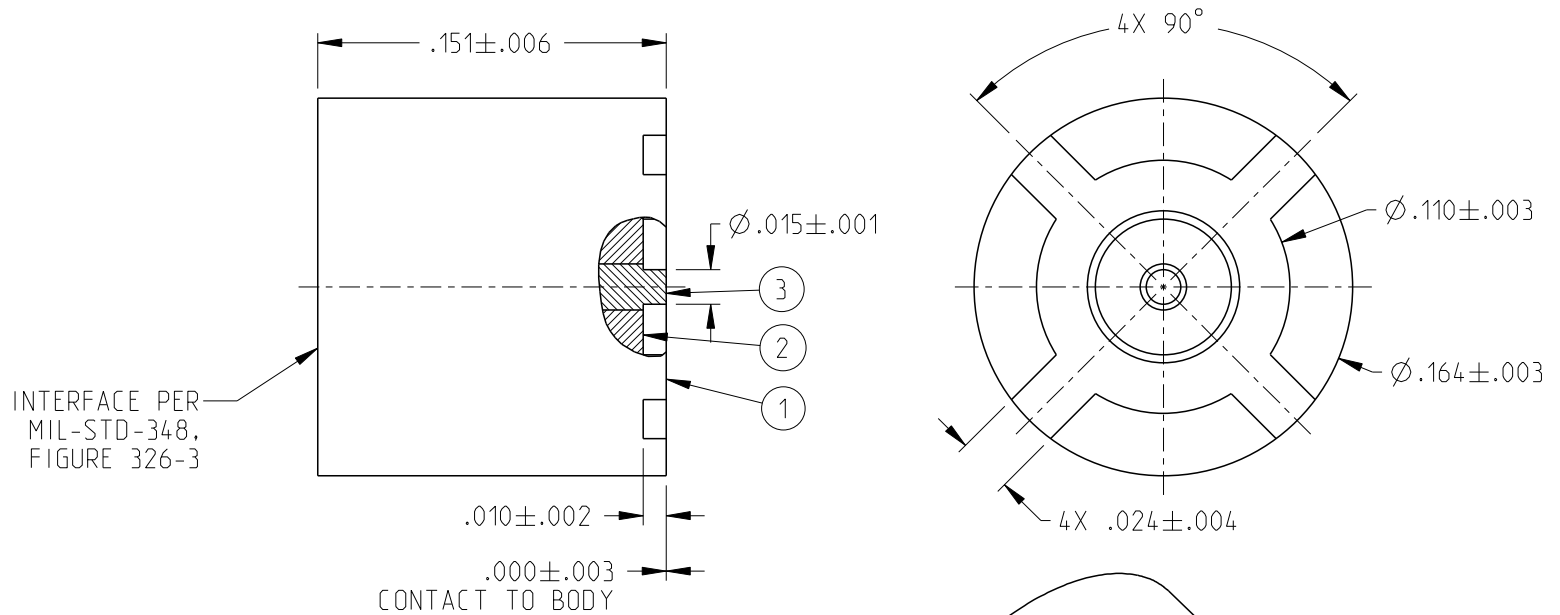

SPECIFICATION:

1. ELECTRICAL SPECIFICATIONS:

- 1.1 FREQUENCY RANGE: 0-18 GHz
- 1.2 IMPEDANCE: 50 OHMS
- 1.3 VSWR: 1.50 MAX TO 18 GHz
- 1.4 INSERTION LOSS: 0.12 √F dB MAX (F IN GHz)
- 1.5 WORKING VOLTAGE (MAX): 325 VRMS AT SEA LEVEL
- 1.6 DIELECTRIC WITHSTANDING VOLTAGE (MIN): 325 VRMS AT SEAL LEVEL
- 1.7 INSULATION RESISTANCE (MIN): 5000 MEGOHMS
- 1.8 CONTACT RESISTANCE:
  - 1.8.1 CENTER CONTACT: INITIAL 6 MILLIOHMS MAX, AFTER ENVIRONMENTAL NOT APPLICABLE
  - 1.8.2 OUTER CONDUCTOR: INITIAL 2 MILLIOHMS MAX, AFTER ENVIRONMENTAL NOT APPLICABLE
- 1.9 RF LEAKAGE: NOT APPLICABLE

2. MECHANICAL SPECIFICATIONS:

- 2.1 ENGAGEMENT FORCE: 10 LBS TYPICAL
- 2.2 DISENGAGEMENT FORCE: 2 LBS TYPICAL
- 2.3 CONTACT RETENTION: 1.0 LBS MIN AXIAL FORCE
- 2.4 DURABILITY(MIN): 500 CYCLES

3. ENVIRONMENTAL:

- 3.1 THERMAL SHOCK: MIL-STD-202, METHOD 107, CONDITION B
- 3.2 OPERATING TEMPERATURE: -65°C TO 165°C
- 3.3 CORROSION: MIL-STD-202, METHOD 101
- 3.4 MECHANICAL SHOCK: MIL-STD-202, METHOD 213, CONDITION I
- 3.5 VIBRATION: MIL-STD-202, METHOD 204
- 3.6 MOISTURE RESISTANCE: MIL-STD-202, METHOD 106, EXCEPT STEP 7B

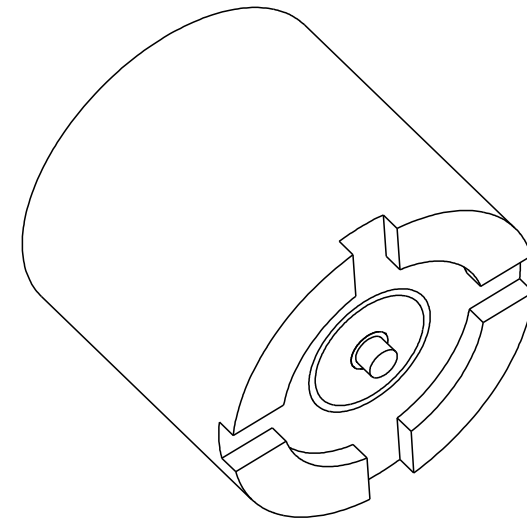

<p>This PROPRIETARY Document is property of Cinch Connectivity Solutions. It is confidential in nature, non-transferable, and issued with the clear understanding that it is not traced or copied without permission and is returnable upon demand.</p> <p>INTERPRET DRAWING IN ACCORDANCE WITH ASME Y14.5-2009.</p>	Model No: 127-1701-221	JOHNSON		
	RoHS2 <input checked="" type="checkbox"/> 2011/65/EU	Cage Code 34078	Title: SMP MALE, STRAIGHT SURFACE MOUNT, LIMITED DETENT	
	UNLESS OTHERWISE SPECIFIED UNITS: INCH	3RD ANGLE PROJECTION	Drawing No. 127-1701-221/230	REV. 1
	Drawn by: TOMMY REN	Date: 12/02/2019	Size A	DO NOT SCALE DRAWING
		Workmanship Std: Sheet QAD-37007	1 OF 1	